

All rights reserved by **CNHi**.

The information contained in this catalogue is intended to be of a general nature only. **CNHi** may at any time and from time to time, for technical or other necessary reasons, modify any of the details or specifications of the product described in this catalogue.

To be sure of getting accurate, detailed and up-to-date information, an intending buyer should consult his nearest **CNHi** dealer or distributor.

Single item numeration method used in this catalogue may not be used without written consent from **CNHi**.

CLICK HERE TO **DOWNLOAD** THE COMPLETE MANUAL

- Thank you very much for reading the preview of the manual.
- You can download the complete manual from: www.heydownloads.com by clicking the link below



- Please note: If there is no response to CLICKING the link, please download this PDF first and then click on it.

CLICK HERE TO **DOWNLOAD** THE COMPLETE MANUAL

TABLE OF CONTENTS

| | | |
|----------|----|--|
| 8.017 | 02 | REGULATOR ASSEMBLY (YN10V01009F1) (HC410), FIGURE 2 OF 2 |
| 8.018 | 00 | VALVE ASSEMBLY, SOLENOID (YN35V00052F1) (HC415) |
| 8.019 | 00 | PUMP ASSEMBLY, GEAR (YN10V00014F2 & YN10V00014F3) (HC420) |
| 8.020 | 00 | PUMP ASSEMBLY (YN10V00040F1) (HC500) |
| 8.021 | 00 | CASE ASSEMBLY, GEAR (YN46W00001F1 & YN46W00001F2) (HC525) |
| 8.022 | 00 | CYLINDER ASSEMBLY, BOOM (YN01V00151F1) (HC600) |
| 8.023 | 00 | CYLINDER ASSEMBLY, ARM (YN01V00175F1) (HC650) |
| 8.024 | 00 | CYLINDER ASSEMBLY, ARM (YN01V00172F1) (HC651) |
| 8.024 | 01 | CYLINDER ASSEMBLY, ARM (EXTREME REACH) (YN01V00132F4) |
| 8.025 | 00 | CYLINDER ASSEMBLY, BUCKET (YN01V00153F1) (HC700) |
| 8.025 | 01 | CYLINDER ASSEMBLY, BUCKET (YX01V00005F1, F2, F3, F4 & F5) |
| 8.025 | 02 | CYLINDER ASSEMBLY, BUCKET (LONG REACH) (YX01V00005F6, F7 & F8) |
| 8.026 | 00 | VALVE ASSEMBLY, PILOT (YN30V00080F1 & YN30V00080F2) (HC825) |
| 8.026 | 01 | VALVE ASSEMBLY, PILOT (YN30V00111F1) |
| 8.027 | 00 | VALVE ASSEMBLY, SOLENOID (YN35V00047F1) (HC850) |
| 8.028 | 00 | VALVE ASSEMBLY, SOLENOID (YN35V00048F1) (HC851) |
| 8.029 | 00 | VALVE ASSEMBLY, SOLENOID (YN35V00049F1) (HC852) |
| 8.030 | 00 | VALVE ASSEMBLY, SOLENOID (YN35V00050F1) (HC853) |
| 8.031 | 00 | VALVE ASSEMBLY, SOLENOID (YN35V00051F1) (HC854) |
| 8.032 | 00 | VALVE ASSEMBLY, SOLENOID (LS35V00002F1) (HC860) |
| 8.033 | 00 | VALVE ASSEMBLY, SOLENOID (LE35V00001F1 & LE35V00001F2) (HC860-82) |
| 8.034 | 00 | VALVE ASSEMBLY, SOLENOID (LS35V00004F1) (HC861) |
| 8.035 | 00 | VALVE ASSEMBLY, SELECTOR (YN30V00117F1) (HC880) |
| 8.036 | 00 | VALVE ASSEMBLY, SELECTOR (YN30V00113F1) (HC881) |
| 8.037 | 00 | VALVE ASSEMBLY, HOLDING (YN28V00019F1 & YN28V00019F2) (HC900) |
| 8.038 | 00 | VALVE ASSEMBLY, HOLDING (YN28V00020F1) (HC901) |
| 8.038.01 | 00 | VALVE ASSEMBLY, RELIEF (YN22V00037F1) |
| 8.039 | 00 | JOINT ASSEMBLY, SWIVEL (YN55V00053F1) (HC930) |
| 8.040 | 00 | VALVE ASSEMBLY, PILOT (PROPELLING) (YN30V00105F1) |
| 8.041 | 00 | MOTOR ASSEMBLY, PROPELLING (YN15V00037F1), USED FROM DATE 03/31/2006 - 02/22/2008, FIGURE 1 OF 2 |
| 8.041 | 01 | MOTOR ASSEMBLY, PROPELLING (YN15V00037F1), USED FROM DATE 03/31/2006 - 02/22/2008, FIGURE 2 OF 2 |
| 8.042 | 00 | MOTOR ASSEMBLY, PROPELLING (YN15V00037F2), USED FROM DATE 02/22/2008 - UP, FIGURE 1 OF 2 |
| 8.042 | 01 | MOTOR ASSEMBLY, PROPELLING (YN15V00037F2), USED FROM DATE 02/22/2008 - UP, FIGURE 2 OF 2 |

1.002

00

p1

4/2021

ENGINE INSTALLATION (YN02P00041F1), FIGURE 1 OF 2

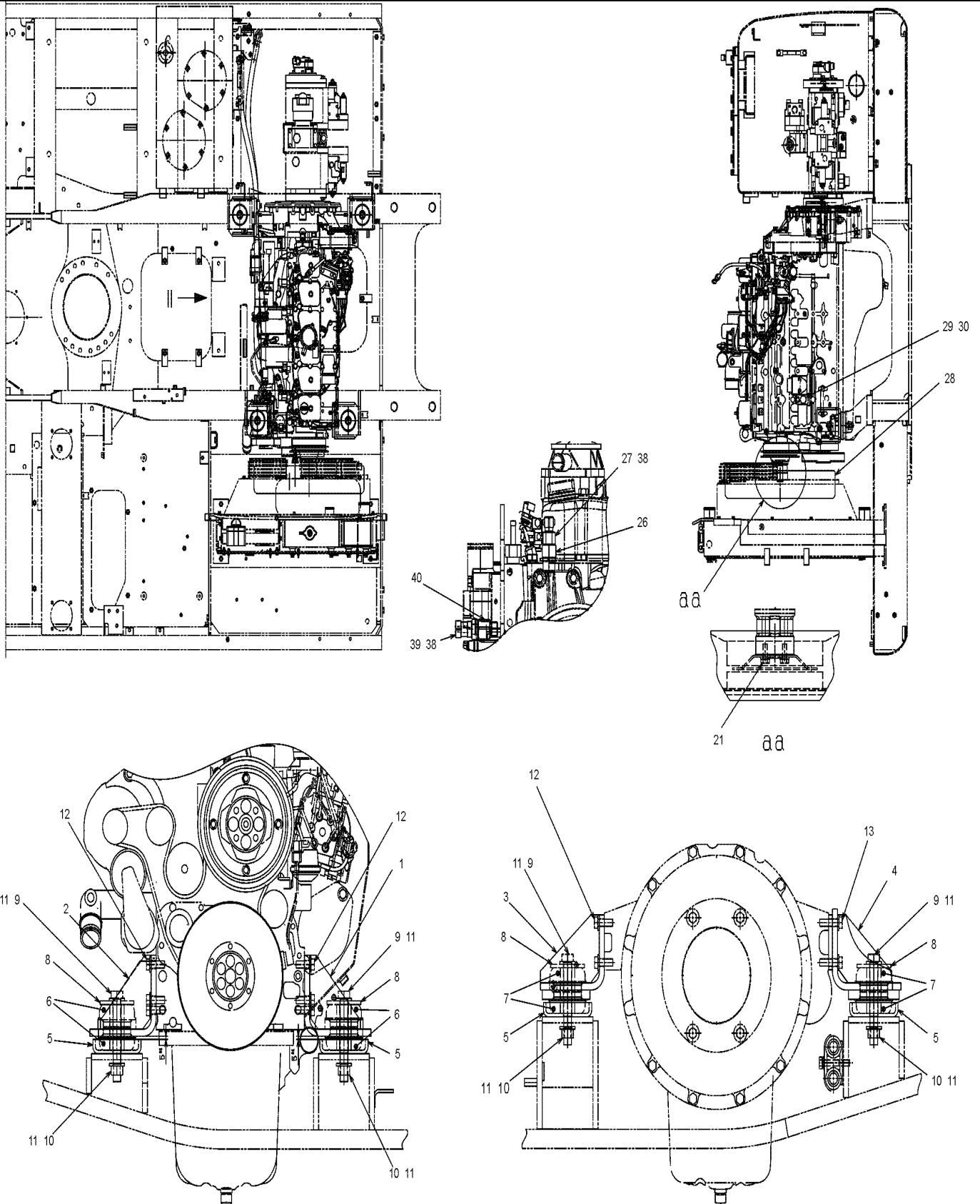

ENGINE INSTALLATION (YN02P00041F1), FIGURE 2 OF 2

| REF FN | PART NUMBER | YR/SN | QTY DESCRIPTION |
|--------|----------------|-------|--|
| 28 | YN75S00007P1 | | 1 FAN 7 Blades, 650mm OD |
| 29 | YN50S00017P1 | | 1 PRESSURE SWITCH M10 x 1.0 x 52mm L (Used for Engine Oil Pressure) |
| 30 | YN02P01037P1 | | 1 ADAPTER M10 x 1.0mm (Incls. O-Ring 637-62081) |
| 30 | 637-62081 | | 1 O-RING 8.1mm ID x 11.3mm OD x 1.6mm Thk, CI 6, 90 Duro (Part of YN02P01037P1), Not Shown |
| 31 | YM02P01028P1 | | 1 CLAMP Double Line -- 145.5x38x36mm |
| 32 | YM02P01029P1 | | 1 PLATE |
| 33 | PY01P01043D5 | | 1 CABLE TIE 4.8mm W x 301mm L |
| 34 | {YN02P01123P1} | | 1 Spacer |
| 35 | HS18C10130G1 | | 4 BOLT M10 x 1.50 x 130mm |
| 36 | ZW16H10000 | | 4 WASHER 11mm ID x 24mm OD x 3.2mm Thk |
| 37 | {YN05P01129P1} | | 1 Connector, Hose -- 1/2"NPTFx64.5mm Long |
| 38 | YN02P01149P1 | | 2 SEAL |
| 39 | YN50S00048P1 | | 1 THERMOSTATIC SWITCH On, 10 Degrees C, 50 Degrees F; Off, -12 Degrees C, 10.4 Degrees F (Used for Engine Temp Sensor) |
| 40 | YN02P01155P1 | | 1 ADAPTER M18 x 1.50 - M14 x 1.50 x 34mm L (Incls. O-Ring 637-63153) |
| 40 | 637-63153 | | 1 O-RING 15.3mm ID x 19.7 OD x 2.2mm Thk, CI 6, 90 Duro (Part of YN02P01155P1), Not Shown |

E215B-CRAWLER EXCAVATOR - TIER 3 (NA) - ASN N7DA21001

1.007

00

p1

4/2021

RADIATOR ASSEMBLY (YN05P00062F1)

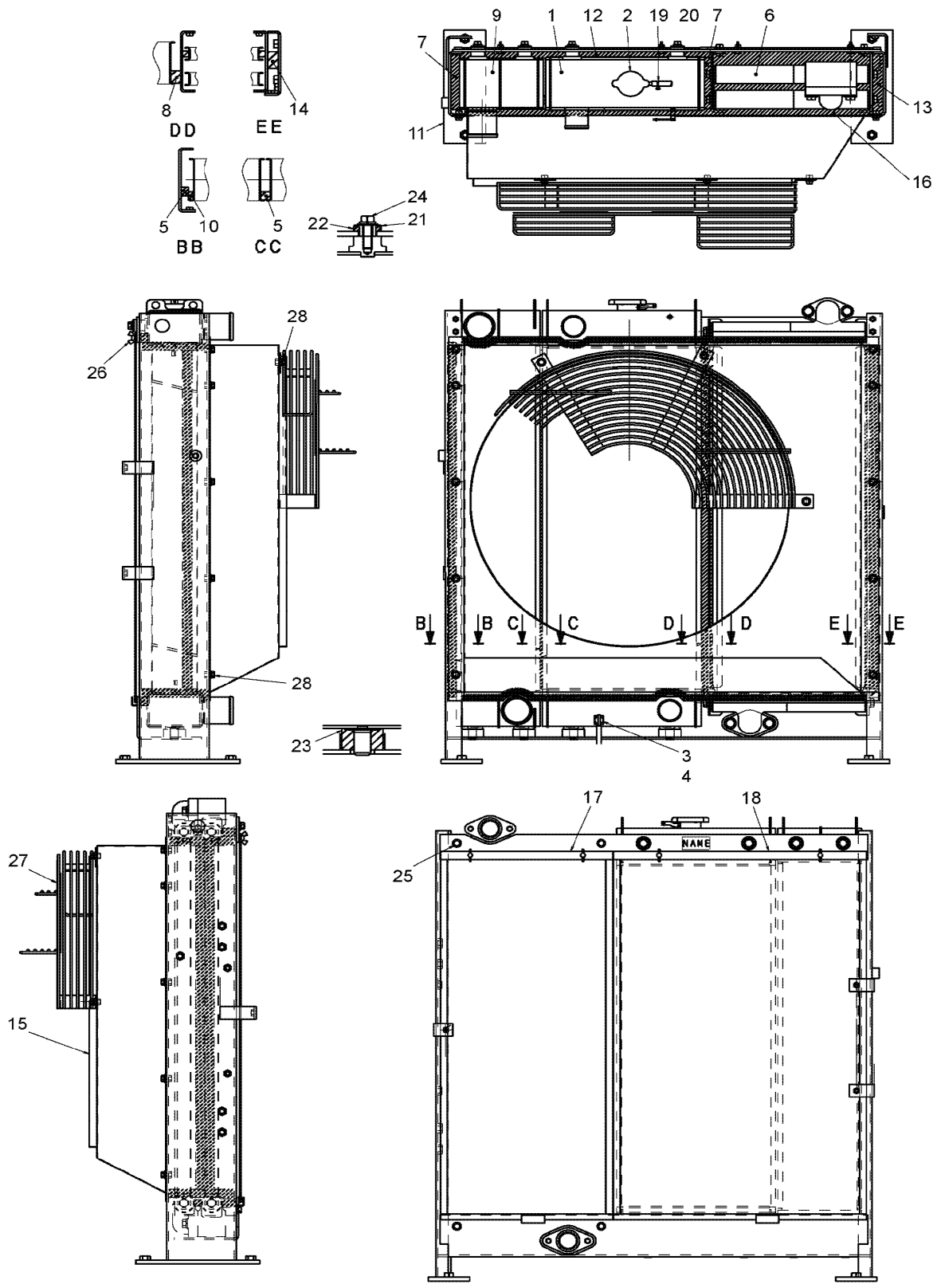

FUEL LINES (YN21P00018F1), USED FROM DATE 03/10/2006 - 03/31/2008

| REF FN | PART NUMBER | YR/SN | QTY DESCRIPTION |
|--------|--------------|-------|---|
| 15 | ZC46X25011 | | 1 CLAMP 25.5mm ID x 20mm W Single Cable |
| 16 | ZC48X12011 | | 1 CLAMP Double Cable |
| 17 | YN13E01375P1 | | 2 CLIP M8 x 8.20mm Shank Anchor Wire Ties |
| 18 | PY01P01043D3 | | 2 CABLE TIE 4.6mm W x 202mm L |
| 19 | YN21P01060P1 | | 1 PLUG No service parts |

E215B-CRAWLER EXCAVATOR - TIER 3 (NA) - ASN N7DA21001

9.000

00

p3

4/2021

ENGINE ASSEMBLY (YN02P00040F1)

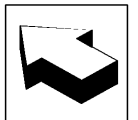
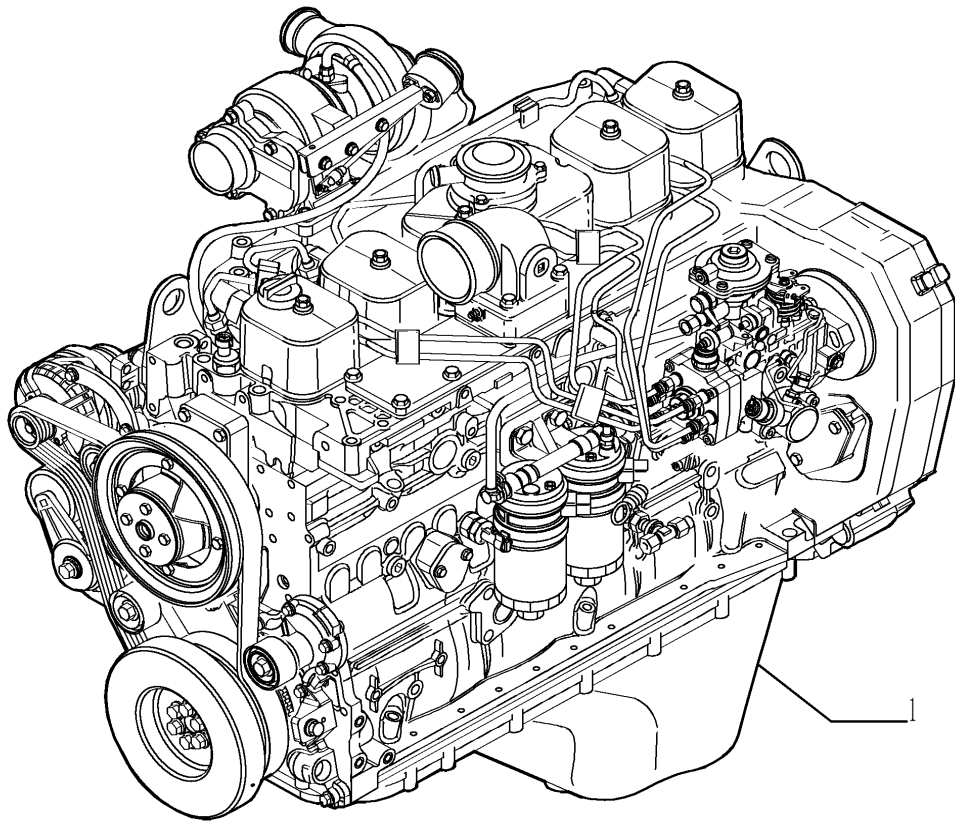

CRANKCASE, FIGURE 2 OF 3

| REF FN | PART NUMBER | YR/SN | QTY DESCRIPTION |
|--------|-------------|-------|---|
| | { | | Crankcase, Figure 2 of 3 |
| 0.066 | { | | See Figure 9.006 |
| 0.082 | { | | See Figure 9.013 |
| 0.120 | { | | See Figure 9.016 |
| 1 | 4894218 | | 6 SCREW Special, M8 x 20 |
| 2 | 4895605 | | 1 HEX SOCKET PLUG M14 x 1.5 (Incls. O-Ring 4899115) |
| 3 | 4899115 | | 1 O-RING 2.2mm Thk x 11.3mm ID (Part of 4895605) |
| 4 | 4899009 | | 1 HEX SOCKET PLUG M10 x1 (Incls. O-Ring 4899072) |
| 5 | 4899072 | | 1 O-RING 1.6mm Thk x 8.1mm ID (Part of 4899009) |
| 6 | 4895392 | | 3 HEX SOCKET PLUG M18 x 1.5 (Incls. O-Ring 4895393) |
| 7 | 4895393 | | 1 O-RING 2.2mm Thk x 15.3mm ID (Part of 4895392) (OD 19.7 mm) |
| 8 | 4895049 | | 2 DOWEL M16.05 x 10 |
| 9 | J931623 | | 12 TAPPET 16mm OD x 60mm H |
| 10 | 87803018 | | 6 LUBE OIL NOZZLE LUBE OIL JET NOZZLE Replaces 504047260 |

E215B-CRAWLER EXCAVATOR - TIER 3 (NA) - ASN N7DA21001

9.005

00

p1

4/2021

ENGINE BREATHER INSTALLATION

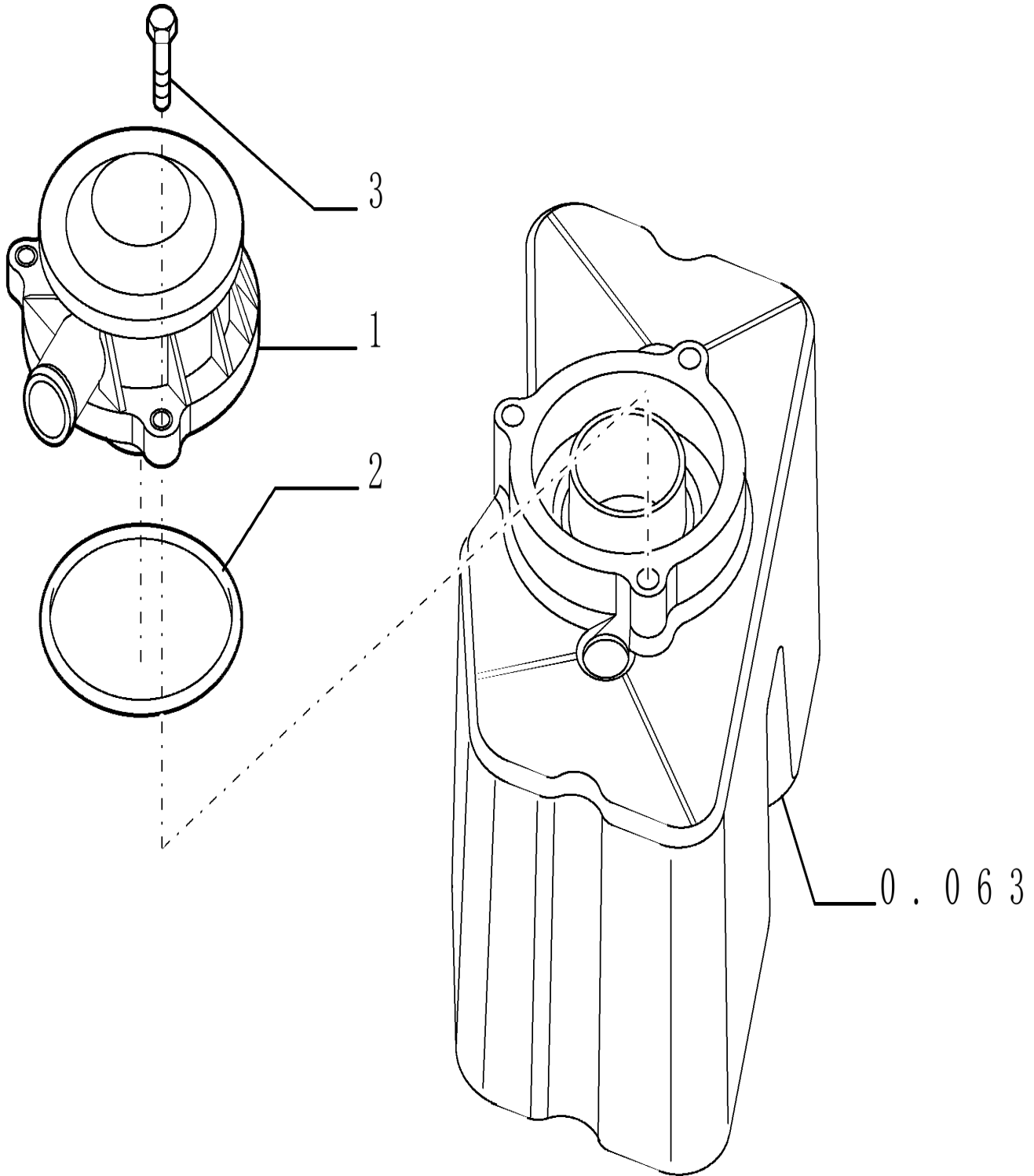

INTAKE MANIFOLD INSTALLATION

| REF FN | PART NUMBER | YR/SN | QTY DESCRIPTION |
|--------|-------------|-------|--|
| | { | | Intake Manifold Installation |
| 0.060 | { | | See Figure 9.006 |
| 1 | 87803125 | | 1 COVER Replaces 504064867 |
| 2 | 4899039 | | 10 SCREW Flng, M8 x 1.25 x 25mm, CI 10.9 |
| 3 | 2831019 | | 1 HEATER 24V |
| 4 | 4899921 | | 2 GASKET 1.2mm Thk |
| 5 | 4893036 | | 1 PIPE PLUG 3/4"-14 NPTF x 12.4 ± 0.5 mm Long |
| 6 | 4895424 | | 1 INLET MANIFOLD |
| 7 | 4895294 | | 4 BOLT Flng, M8 x 1.25 x 80mm, CI 10.9 M8x1.25x140mm |

E215B-CRAWLER EXCAVATOR - TIER 3 (NA) - ASN N7DA21001

9.015

00

p1

4/2021

CRANKSHAFT PULLEY INSTALLATION

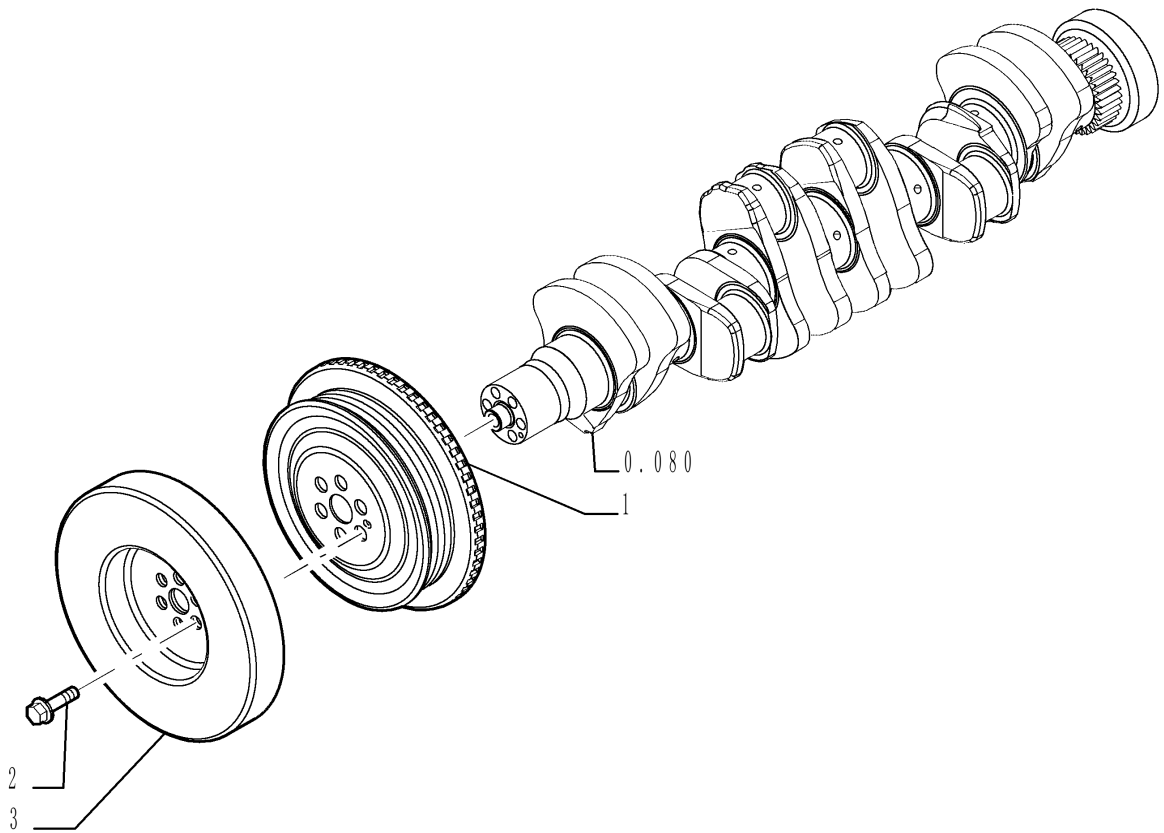

9.017

04

p1

4/2021

INJECTION PUMP ASSY (2855718)

| REF FN | PART NUMBER | YR/SN | QTY DESCRIPTION |
|--------|-------------|-------|---|
| 1 | 2855718 | | 1 FUEL INJECTION PUMP DISTRIB.INJ.PUMP |
| 2 | 504032877 | | 1 TEMPERATURE SENDER SENSOR, water temperature for KSB |
| 3 | 8036949 | | 1 ELECTROMAGNET SOLENOID, 24V - KSB (Used for Cold Start) |
| 4 | 2852088 | | 1 WIRE HARNESS WIRE/CABLE, for electrovalve & ksb |
| 5 | 42547161 | | 1 SOLENOID SOLENOID, KSB (Used for Fuel Shut Off) |

E215B-CRAWLER EXCAVATOR - TIER 3 (NA) - ASN N7DA21001

9.022

00

p1

4/2021

TURBOCHARGER

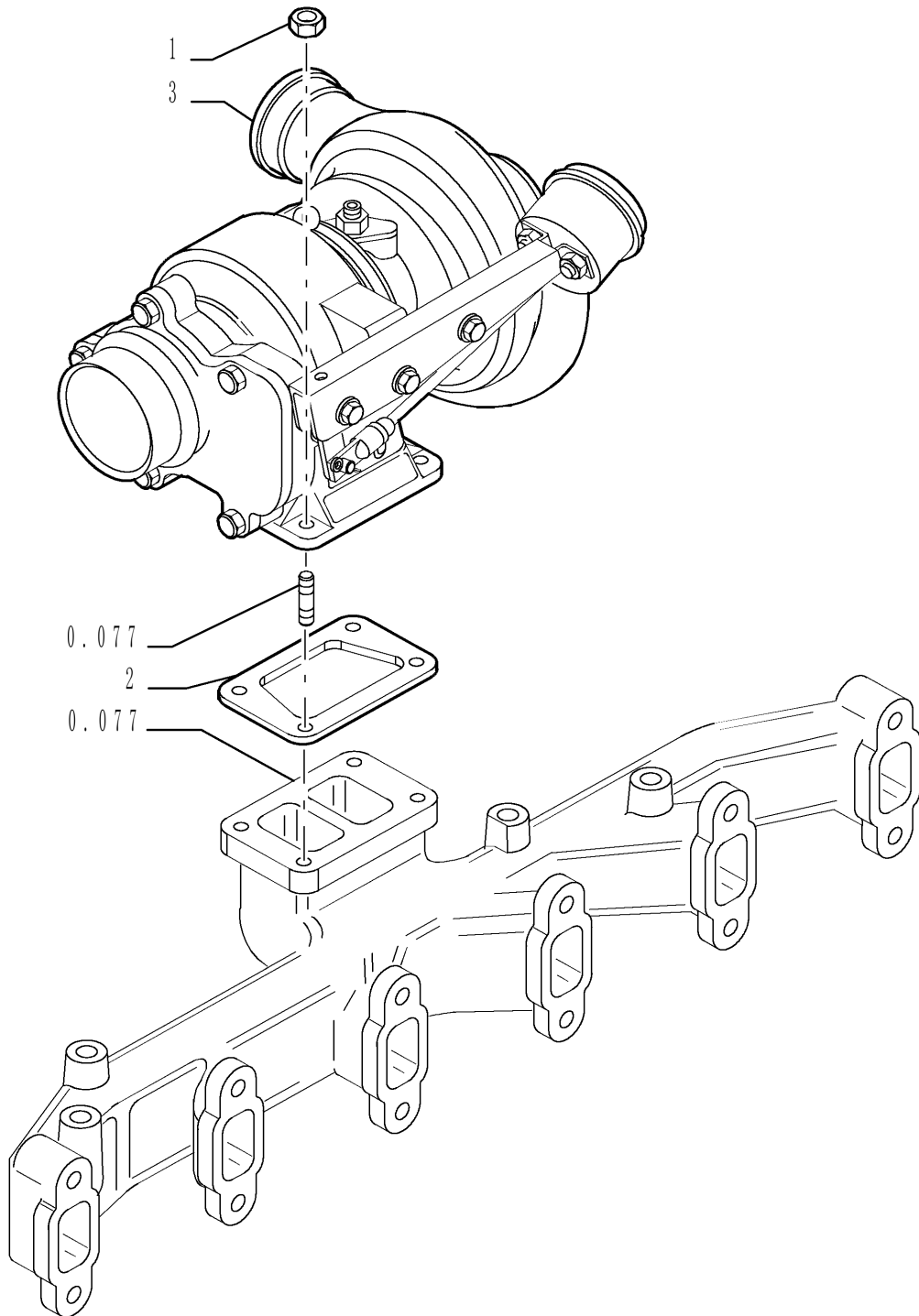

HEAT EXCHANGER - ENGINE

| REF FN | PART NUMBER | YR/SN | QTY DESCRIPTION |
|--------|-------------|-------|--|
| | { | | Heat Exchanger - Engine |
| 0.040 | { | | See Figure 9.002 |
| 1 | 4899019 | | 15 SCREW Hex Flg, M8 x 1.25 x 35 M08x1.25x35mm |
| 2 | 4899643 | | 1 FILTER HEAD |
| 3 | 2853781 | | 1 PLUG Hex, M22 x 1.5 ORB Replaces 504096409 |
| 4 | 4896404 | | 1 PLUNGER 10mm ID, 12mm OD, 15.44mm ID, 18.26mm OD |
| 5 | 4895045 | | 1 COMPRESSION SPRING Compression, 14.7mm OD x 66mm L |
| 6 | 17916280 | | 1 SEAL |
| 7 | J936365 | | 1 VALVE PRESSURE RELIEF |
| 8 | 4893391 | | 1 ADAPTER ADAPTER, M24x2 TO M27x2 |
| 9 | 2853604 | | 1 OIL COOLER Replaces 4896407 |
| 10 | 2830559 | | 1 GASKET 0.5mm Thk |
| 11 | 4896409 | | 1 GASKET 1.55mm Thk |
| 12 | 2853436 | | 1 BRACKET Replaces 500389886 |
| 13 | 76046537 | | 2 SEAL 0.139" Thk x 2.359" ID, -229, Cl 5, 75 Duro Replaces 17290181 |
| 14 | 2853438 | | 1 THREADED BUSHING Replaces 500396330 |

E215B-CRAWLER EXCAVATOR - TIER 3 (NA) - ASN N7DA21001

9.033

00

p1

4/2021

POWER TAKE OFF

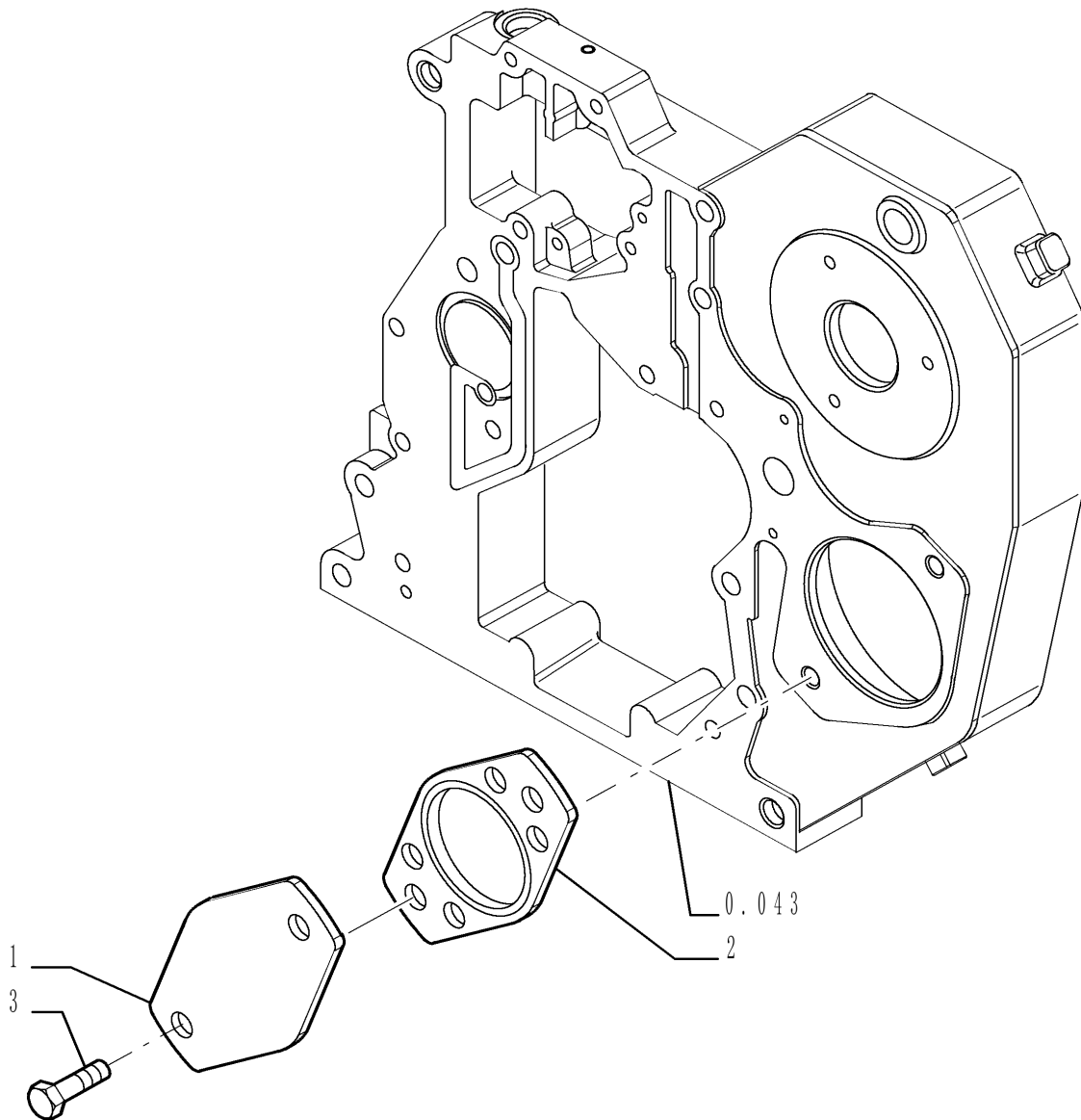

9.036

00

p1

4/2021

LIFTING HOOKS INSTALLATION

| REF FN | PART NUMBER | YR/SN | QTY DESCRIPTION |
|--------|-------------|-------|--|
| | { | | Lifting Hooks Installation |
| 0.021 | { | | See Figure 9.030 |
| 0.326 | { | | See Figure 9.001 |
| 1 | 2852183 | | 1 BRACKET |
| 2 | 4899073 | | 2 FLANGE BOLT Hex Flg, M12 x 1.75 x 30mm M12x1.75x30mm |

E215B-CRAWLER EXCAVATOR - TIER 3 (NA) - ASN N7DA21001

2.004

00

p1

4/2021

IDLER ASSEMBLY (YN52D00034F1)

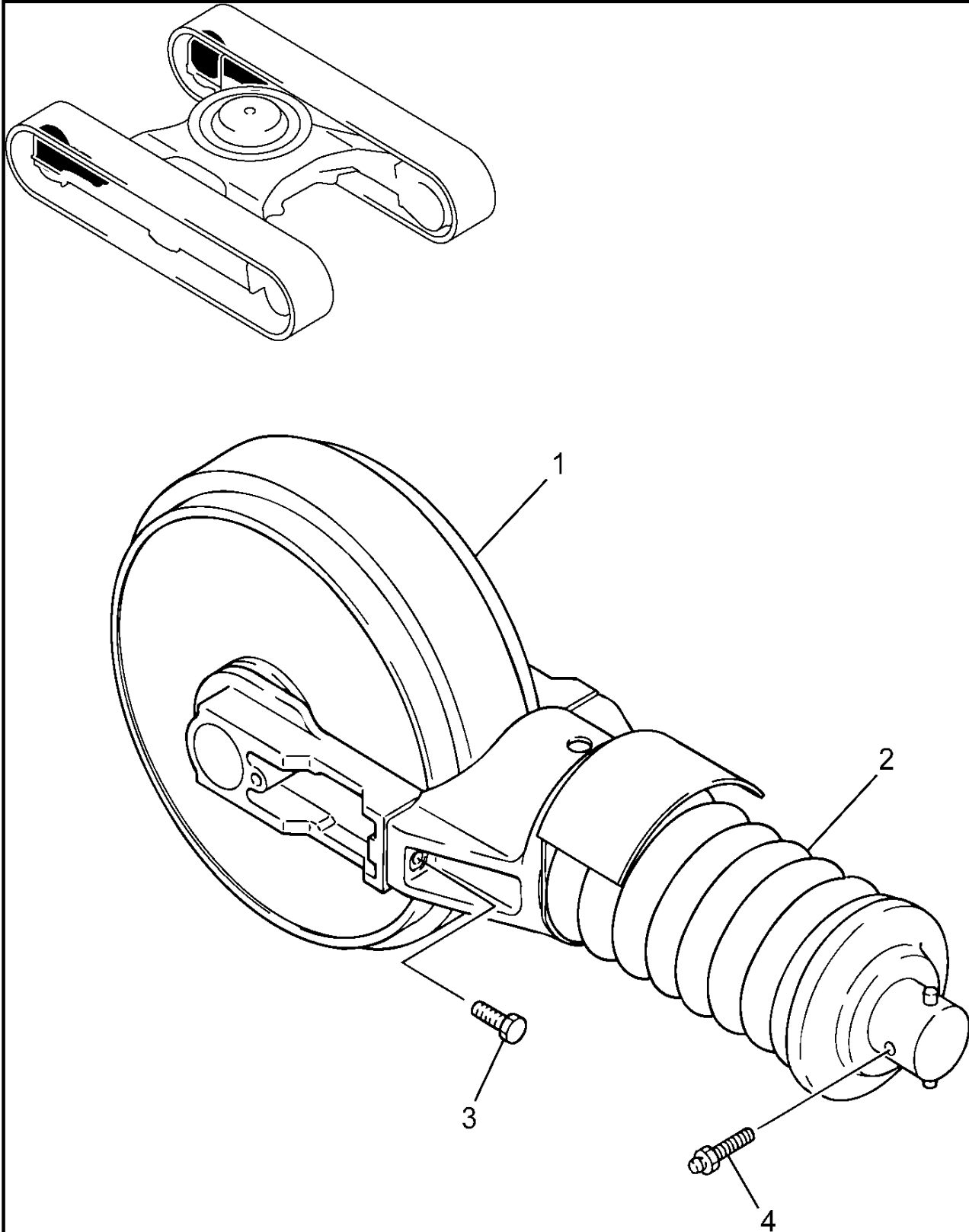

DC06G152

2.007

00

p1

4/2021

UPPER ROLLER ASSEMBLY (YN64D00032F1)

| REF FN | PART NUMBER | YR/SN | QTY DESCRIPTION |
|--------|--------------|-------|--|
| | ⌋ | | Upper Roller Assembly, YN64D00032F1, Incls. Refs. 1-4 |
| 1 | YN64D01068F1 | | 4 ROLLER Assembly, Incls. Refs. 1-1 - 1-11 |
| 1-1 | 2413N469 | | 1 ROLLER 48mm ID x 140mm OD x 150mm W |
| 1-2 | YN64D01069P1 | | 1 SHAFT 45mm OD x 46mm OD x 183mm L |
| 1-3 | 2418P21176 | | 1 COLLAR 46mm ID x 61mm OD x 78mm OD x 40mm W |
| 1-4 | YN64D01038P1 | | 1 PLATE 68mm OD x 9mm Thk |
| 1-5 | YN64D01026P1 | | 1 COVER 75mm OD x 27mm W |
| 1-6 | 2405T852 | | 1 BUSHING 45mm ID x 50mm OD x 50mm L ID 45 x OD 50 x 50mm Long |
| 1-7 | 2445R361F1 | | 1 SEAL 45mm ID x 68.6mm OD x 27mm Thk |
| 1-8 | ZD11P06500 | | 1 O-RING 64.6mm ID x 76mm OD x 5.7mm Thk ID 64.6 ± 0.57 x OD 75mm |
| 1-9 | YN64D01016P1 | | 2 BOLT M12 x 1.75 x 28mm M12x1.75x28mm |
| 1-10 | ZE82T04000 | | 1 PLUG 1/4" PT 1/4" PT |
| 1-11 | ZR26X07500 | | 1 SNAP RING 75mm ID x 79.5mm OD x 2.5mm Thk Retaining -- ID 75 x OD 79.5 x Th 2.5mm |
| 2 | YN52F01100D3 | | 4 CAP M20 x 2.5 x 100mm Screw, M20x2.50x100mm -- Replaces YN64D01012P1, M20x2.50x100mm |
| 3 | ZN13C20016 | | 4 NUT M20 x 2.50mm M20x2.50mm |
| 4 | ZW13H20000 | | 4 WASHER 21mm ID x 40mm OD x 4.5mm Thk ID 20 x OD 40 x Th 4.5mm |

E215B-CRAWLER EXCAVATOR - TIER 3 (NA) - ASN N7DA21001

2.010

00

p1

4/2021

LOWER HYDRAULIC LINES (YN02H00071F1, YN19H00054F1 & YN12H00012F1), FIGURE 2 OF 2

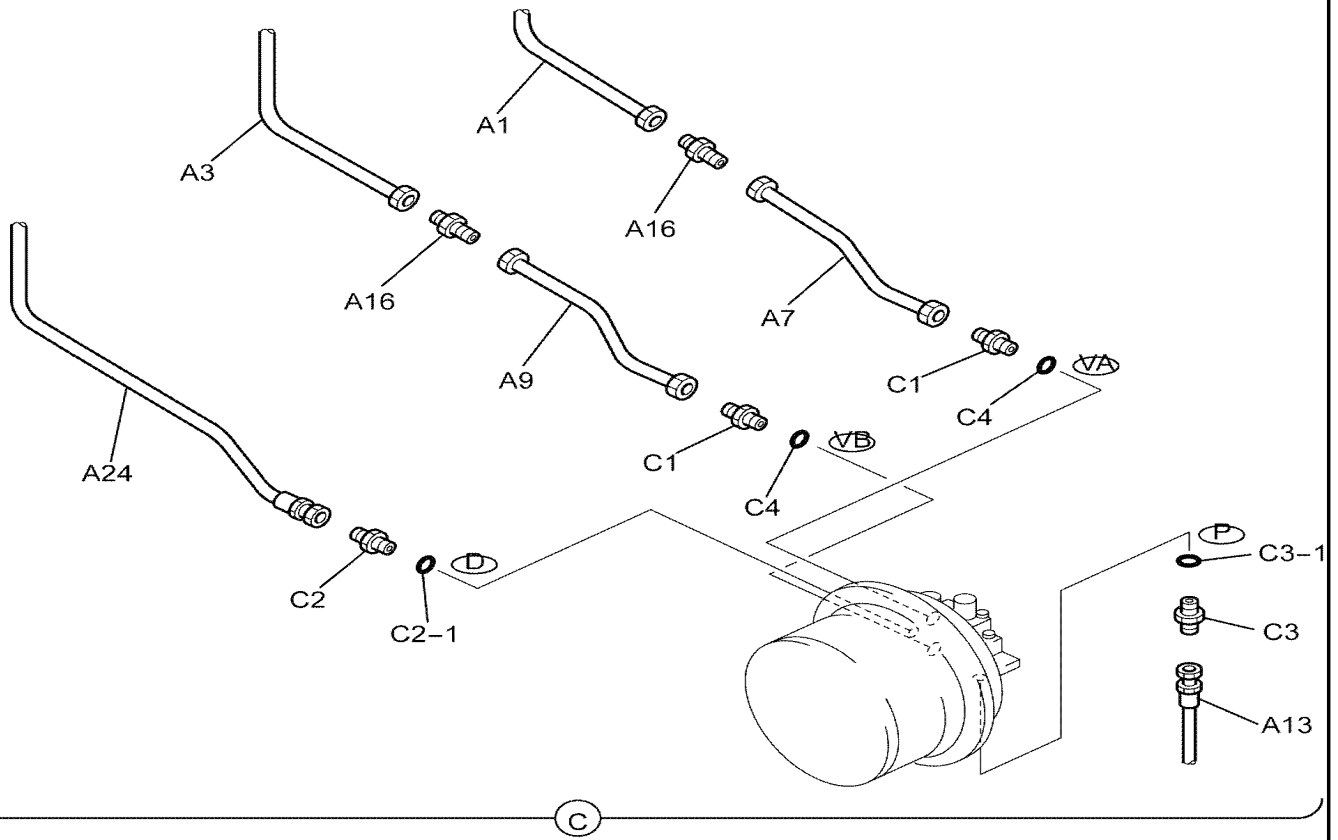

C

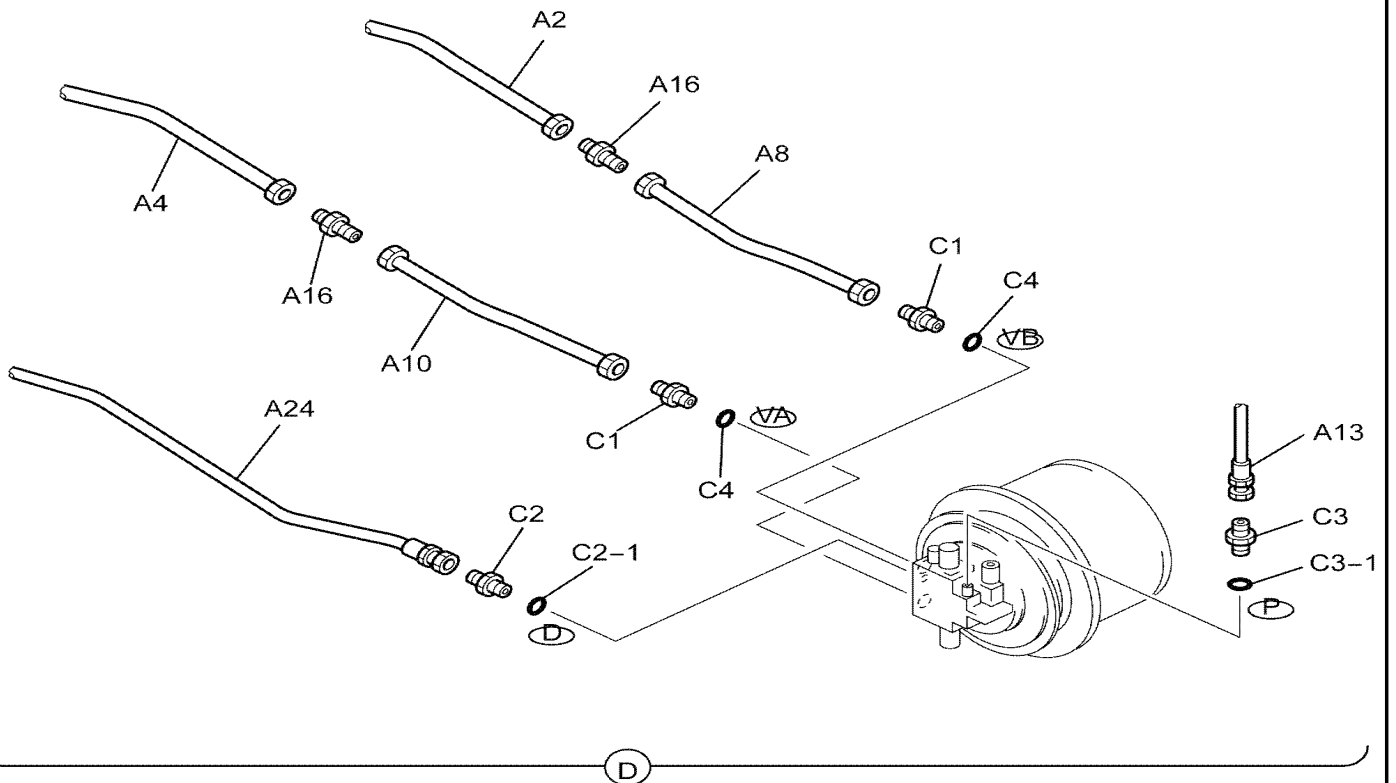

D

SECTION INDEX

SUPERSTRUCTURE

| | | |
|----------|----|--|
| 3.011 | 00 | BUCKET INSTALLATION (YN61B00007F2) |
| 3.012 | 00 | BOOM, LONG REACH (LC02BU0007F1) |
| 3.013 | 00 | CASE ASSEMBLY, GEAR (YN46W00001F2) |
| 3.014 | 00 | CASE ASSEMBLY, GEAR (YN46W00002F6) |
| 3.015 | 00 | VALVE INSTALLATION (ROTATION) (YN64H00196F1) |
| 4.001 | 00 | TOOL & ACCESSORY (YN01T00151F4) |
| 4.002 | 00 | ELEMENT KIT (YN30TU0003F1) |
| 5.001 | 00 | VALVE INSTALLATION (NIBBLER & BREAKER) (YN64H00190F1) |
| 5.002 | 00 | HYDRAULIC LINES, UPPER (NIBBLER & BREAKER) (YN03H00123F1) |
| 5.003 | 00 | CONTROLS, OPERATOR (NIBBLER & BREAKER) (YN03M00153F1) |
| 5.004 | 00 | CONTROL LINES, VALVE (NIBBLER & BREAKER) (YN64H00283F1) |
| 5.005 | 00 | CONTROL LINES, VALVE (NIBBLER & BREAKER W/ROTATION) (YN64H00257F1) |
| 5.006 | 00 | CONTROL LINES, VALVE (ROTATION) (YN64H00233F1) |
| 5.007 | 00 | CONTROL LINES, MULTI (YN64H00289F1) |
| 5.008 | 00 | CONTROL LINES, VALVE (HOLDING VALVE) (YN64H00198F1) |
| 5.009 | 00 | CONTROL LINES, PUMP (YN06H00077F1) |
| 5.010 | 01 | CONTROL LINES, BLOCK (PT-2PEDAL) (YN64H00184F1) |
| 5.011 | 00 | CONTROL LINES, BLOCK (STANDARD) (YN64H00258F1) |
| 5.012 | 00 | CONTROL LINES, BLOCK (2 WAY) (YN64H00261F1) |
| 5.013 | 00 | CONTROL LINES, REMOTE (NIBBLER & BREAKER - FOOT) (YN68H00138F1), FIGURE 1 OF 2 |
| 5.014 | 00 | CONTROL LINES, REMOTE (NIBBLER & BREAKER - FOOT) (YN68H00138F1), FIGURE 2 OF 2 |
| 5.015 | 01 | CONTROL LINES, REMOTE (NIBBLER & BREAKER - HAND) (YN68H00150F1) |
| 5.015-01 | 00 | VALVE ASSEMBLY, SOLENOID (LC35V00004F1, F2 & F3) |
| 5.016 | 00 | INSTRUMENT PANEL ASSEMBLY (NIBBLER & BREAKER) (YN17M00064F1), FIGURE 1 OF 3 |
| 5.016 | 01 | INSTRUMENT PANEL ASSEMBLY (NIBBLER & BREAKER) (YN17M00064F1), FIGURE 2 OF 3 |
| 5.016 | 02 | INSTRUMENT PANEL ASSEMBLY (NIBBLER & BREAKER) (YN17M00064F1), FIGURE 3 OF 3 |
| 5.016-00 | 00 | GAUGE ASSEMBLY, CLUSTER (YN59S00021F1 & YN59S00021F2) |
| 5.035 | 00 | HARNESS ASSEMBLY, UPPER (PATTERN CHANGER) (YN13E00114F1) |
| 5.036 | 00 | HARNESS ASSEMBLY, UPPER (NIBBLER & BREAKER, HAND) (LC13E00052F1) |
| 5.037 | 00 | HARNESS ASSEMBLY, UPPER (NIBBLER & BREAKER W/ROTATION + HAND) (LC13E00051F1) |
| 5.038 | 00 | HARNESS ASSEMBLY, UPPER (ROTATION) (LC13E00056F1) |
| 5.039 | 00 | SUN VISOR ASSEMBLY (YN55C00013F1) |
| 5.040 | 00 | CONTROL LINES, MAIN (EXTREME REACH) (YN06H00104F1), FIGURE 1 OF 2 |

1.001

00

p1

4/2021

UPPER FRAME GROUP (HIGH & WIDE) (BOLT SPACER) (YN52FU0012F1)

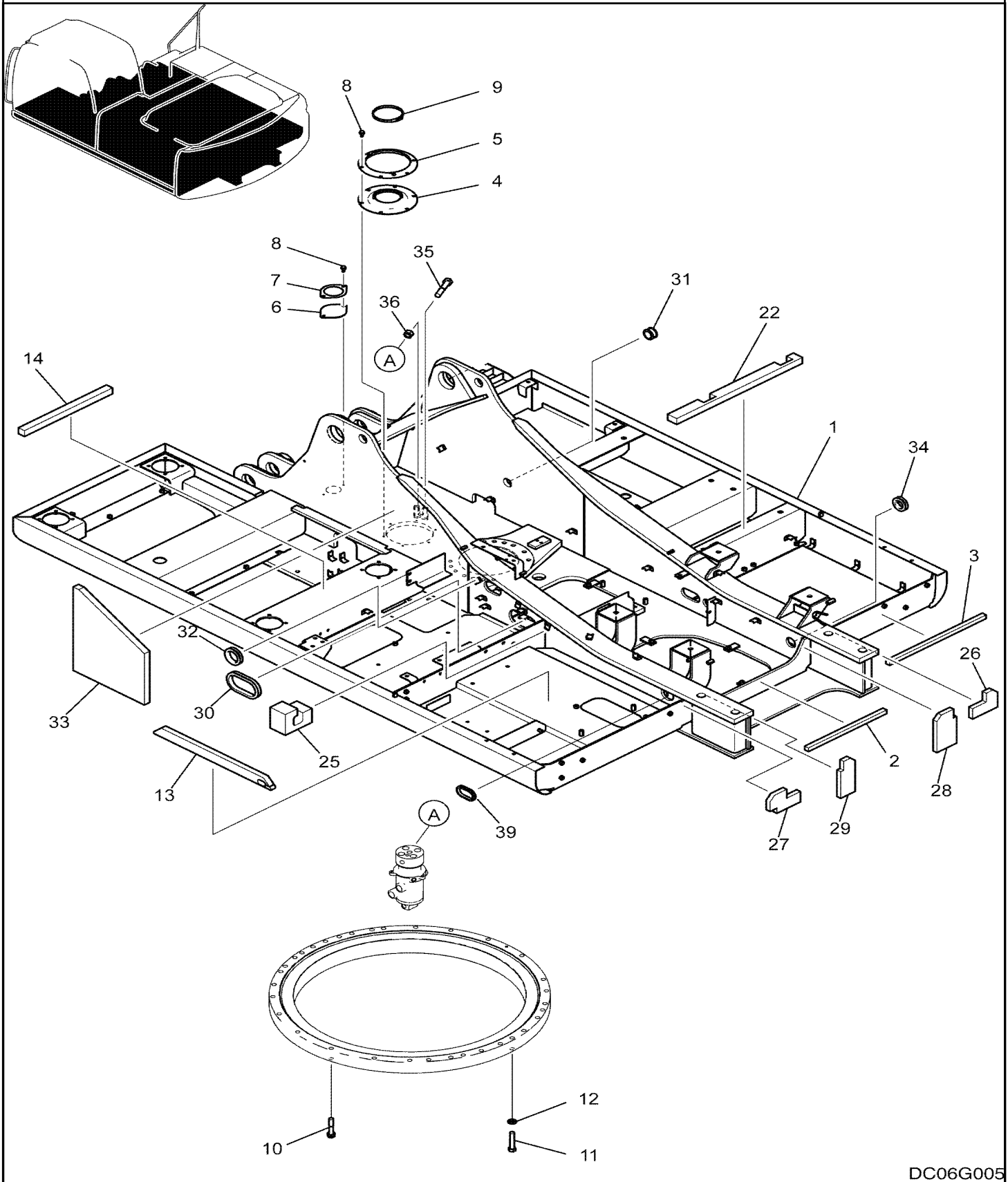

HYDRAULIC TANK ASSEMBLY (YN33H00076F1), USED AFTER DATE 01/18/2008 - UP

| REF FN | PART NUMBER | YR/SN | QTY DESCRIPTION |
|--------|----------------|-------|---|
| . | { } | | Hydraulic Tank Assembly, YN33H00076F1, Used from date 01/18/2008 - UP |
| . | { } | | Hydraulic Tank Installation, YN33H00058F1, Incls. Refs. A1-A3 |
| A1 | ZS13C16040 | | 4 SCREW M16 x 2.0 x 40mm |
| A2 | ZW13H16000 | | 4 WASHER 17mm ID x 32mm OD x 4.5mm Thk |
| A3 | LE33H01017D1 | | 3 SHIM 1.0mm Thk |
| . | { } | | Hydraulic Tank Assembly, YN33H00082F1, Incls. Refs. B2-B6 |
| B2 | YN50V00025F1 | | 1 HYDRAULIC OIL FILTER Suction, Incls. Refs. B2-1 - B2-6 |
| B2-1 | YN50V00002S001 | | 1 HYDRAULIC OIL FILTER 150mm OD x 90mm H Suction |
| B2-2 | NSS | | 1 NOT SOLD SEPARAT O-Ring (Part of YN50V00002S001) |
| B2-3 | 2446R110S2 | | 1 HOLDER Plate |
| B2-4 | LS50V00007S003 | | 1 BOLT M10 x 1.50 x 585mm |
| B2-5 | ZN11C10008 | | 2 NUT M10 x 1.50 |
| B2-6 | 2446R110S6 | | 1 SPRING |
| B3 | YN57V00004F1 | | 1 BREATHER Assembly, Incls. Refs. B3-1 - B3-8 |
| B3-1 | NA | | 1 NOT SERVICED Body Assembly |
| B3-2 | YN57V00004S002 | | 1 FUEL FILTER 51mm OD x 39mm H Breather |
| B3-3 | NA | | 1 NOT SERVICED Cover |
| B3-4 | NA | | 1 NOT SERVICED Seal |
| B3-5 | NA | | 1 NOT SERVICED Nut |
| B3-6 | 2446U260S10 | | 1 NUT M12 x 1.25 |
| B3-7 | NA | | 1 NOT SERVICED Seal |
| B3-8 | 2446U260S8 | | 1 PACKING 55mm ID x 90mm OD x 1.5mm Thk |
| B4 | ZS28C06016 | | 4 SCREW Hex Socket Head, M6 x 1.0 x 16mm |

E215B-CRAWLER EXCAVATOR - TIER 3 (NA) - ASN N7DA21001

1.016

00

p1

4/2021

HYDRAULIC LINES, PUMP (YN30H00046F1), FIGURE 1 OF 2

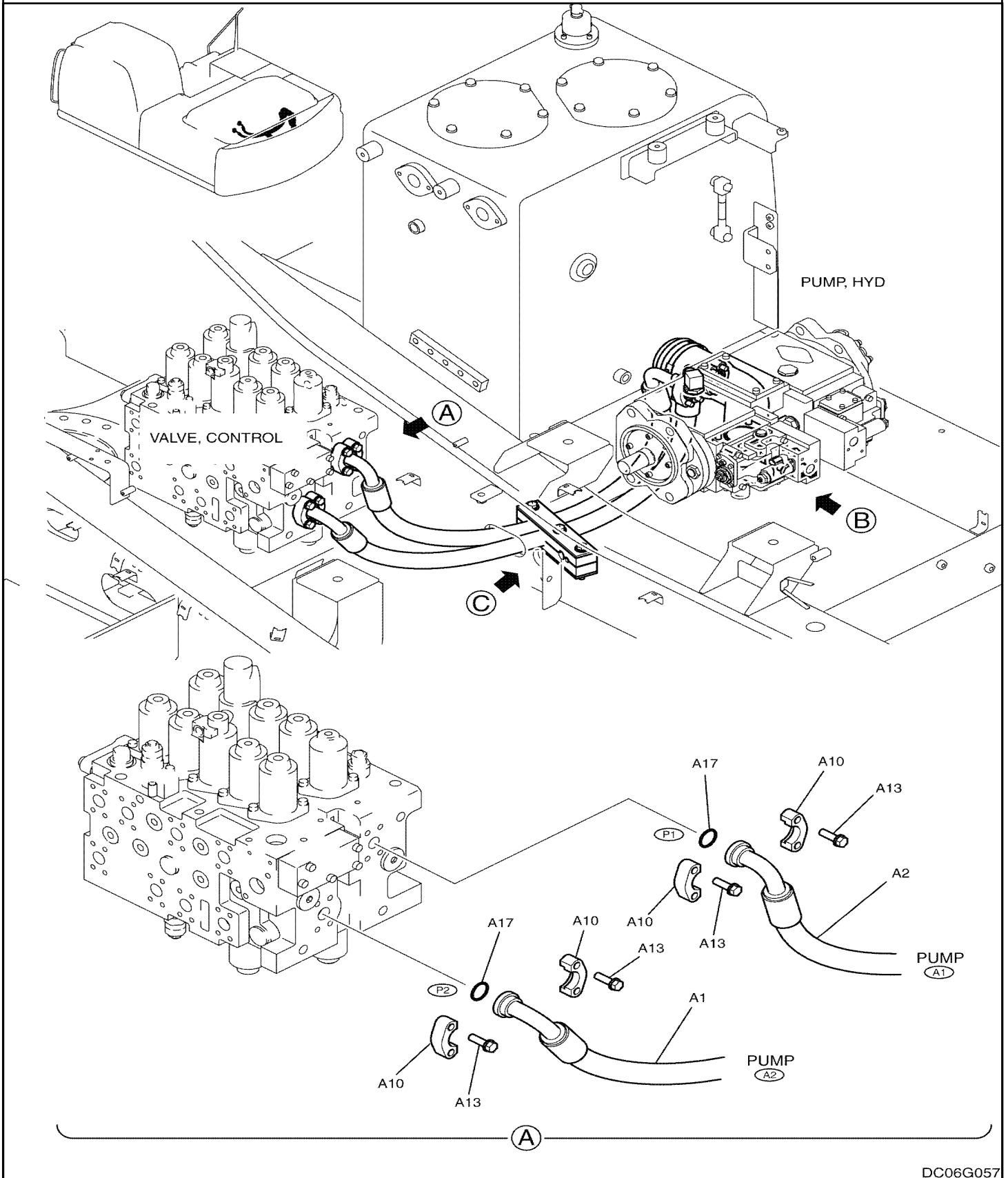

1.018

00

p2

4/2021

HYDRAULIC LINES UPPER (STANDARD) (YN03H00122F1), FIGURE 1 OF 2

| REF FN | PART NUMBER | YR/SN | QTY DESCRIPTION |
|--------|----------------------------|-------|--|
| A17 | ZG23F12012 | | 2 HYD CONNECTOR 1 3/16" - 12UN x PF 3/4" x 48mm L 1 3/16" 12UN-3/4" PT x 48mm Long (Incls. O-Ring ZD12P02400) |
| A17-1 | ZD12P02400 | | 1 O-RING 23.7mm ID x 30.7mm OD x 3.5mm Thk (Part of ZG23F12012), ID 23.70 ± 0.24 x OD 30mm |
| A18 | ZE12X16000 | | 20 CLAMP Half -- (Incls. Capscrew & Lockwasher) |
| A19 | HM83C10035G1 | | 48 BOLT M10 x 35mm M10x35mm |
| A20 | ZM73C12035 | | 2 BOLT M12 x 1.75 x 35mm - Course Thread M12x1.75x35mm (Incls. Washer) |
| A21 | ZS18C10075 | | 2 SCREW Hex, M10 x 1.50 x 75mm M10x1.50x75mm |
| A22 | ZS18C10060 | | 4 SCREW Hex, M10 x 1.50 x 60mm M10x1.50x60mm |
| A23 | ZW16H10000 | | 6 WASHER 11mm ID x 24mm OD x 3.2mm Thk ID 11 x OD 24 x Th 3.2mm |
| A24 | ZD12A01600 | | 2 O-RING 15.60mm ID x 19.16mm OD x 1.78mm Thk ID 15.60 ± 0.12 x OD 19.16mm |
| A25 | ZD12A01800 | | 2 O-RING 18.77mm ID x 22.33mm OD x 1.78mm Thk ID 18.77 ± 0.12 x OD 22.33mm |
| A26 | ZD12A02100 | | 2 O-RING 23.52mm ID x 27.08mm OD x 1.78mm Thk ID 23.52 ± 0.15 x OD 27.08mm |
| A27 | ZD12P03400 | | 12 O-RING 33.7mm ID x 40.7mm OD x 3.5mm Thk ID 33.70 ± 0.33 x OD 40mm |
| | } | | Upper Hydraulic Lines, YN03H00126F1, Incls. Refs. B1 - B7 |
| B1 | YN03H01884P1 ZD12P04800 | | 1 PLUG (Incls. O-Ring ZD12P04800) 1 O-RING 47.7mm ID x 54.7mm OD x 3.5mm Thk (Part of YN03H01884P1), ID 47.70 ± 0.44 x OD 54.7mm, Not Shown |
| B2 | ZE12Q16000 | | 2 PLUG (Incls. O-Ring ZD12P03400) |

E215B-CRAWLER EXCAVATOR - TIER 3 (NA) - ASN N7DA21001

1.021

00

p1

4/2021

HYDRAULIC LINES RETURN (YN32H00051F1), FIGURE 1 OF 2

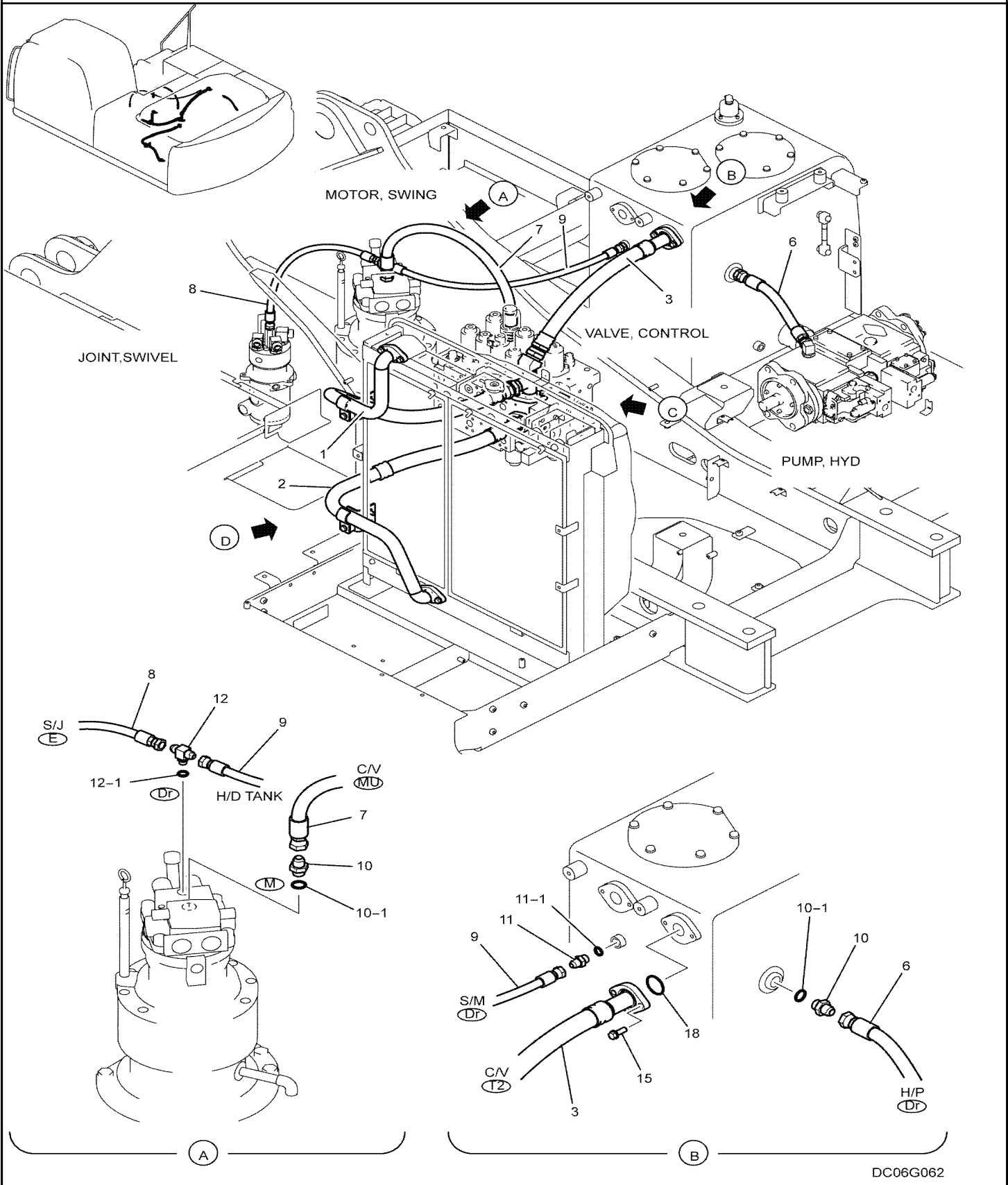

1.023

00

p2

4/2021

CONTROL, OPERATORS (STANDARD) (YN03M00148F1), FIGURE 1 OF 2

| REF FN | PART NUMBER | YR/SN | QTY DESCRIPTION |
|---------------|--------------------|--------------|---|
| 13 | ZW16P08000 | | 4 WASHER 8mm ID x 17mm OD x 1.6mm Thk ID 08 x OD 17 x Th 1.6mm |
| 14 | ZS28C08020 | | 4 SCREW Hex Socket Head, M8 x1.25 x 20mm M08x1.25x20mm |
| 15 | YN02C02055P1 | | 1 TRAY Ash |
| 16 | ZM66C06016 | | 12 BOLT M6 x 1.0 x 16mm M06x1.0x16mm (Incls. Washer & Lockwasher) |
| 17 | ZM73C08025 | | 4 BOLT M8 x 1.25 x 25mm - Course Thread M08x1.25x25mm (Incls. Washer) |
| 18 | YN20M01643P1 | | 1 SPRING Not Shown |
| 19 | YT03M01222P1 | | 1 GROMMET Not Shown |

E215B-CRAWLER EXCAVATOR - TIER 3 (NA) - ASN N7DA21001

1.028

00

p1

4/2021

CONTROL, OPERATORS (NO BOOST, PEDAL) (YN03M00181F1)

ART

NOT

AVAILABLE

GRIP ASSEMBLY (YN03M01974F1)

| REF FN | PART NUMBER | YR/SN | QTY DESCRIPTION |
|--------|--------------|-------|---|
| . | ⌋ | | Grip Assembly, YN03M01974F1, Incls. Refs. 1-5 |
| 1 | YN03M02021F3 | | 1 GRIP Assembly Right Hand, (With no Switch) Replaces YN03M01973F1 |
| 2 | YN03M02021F1 | | 1 HANDLE GRIP Assembly Left Hand, (With Horn) Replaces YN03M01862F1 |
| 3 | YN03M01498P1 | | 2 BELLOWS Boot |
| 4 | YN03M01328P2 | | 2 PLATE |
| 5 | ZN18C14011 | | 2 NUT M14 x 2.0 |

E215B-CRAWLER EXCAVATOR - TIER 3 (NA) - ASN N7DA21001

1.037

01

p1

4/2021

PEDAL ASSEMBLY (YN55M00004F1)

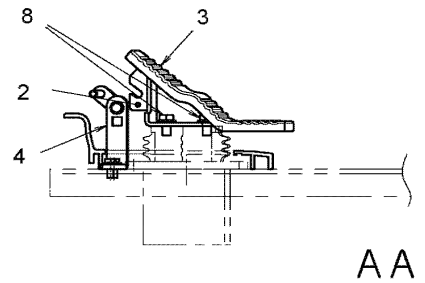
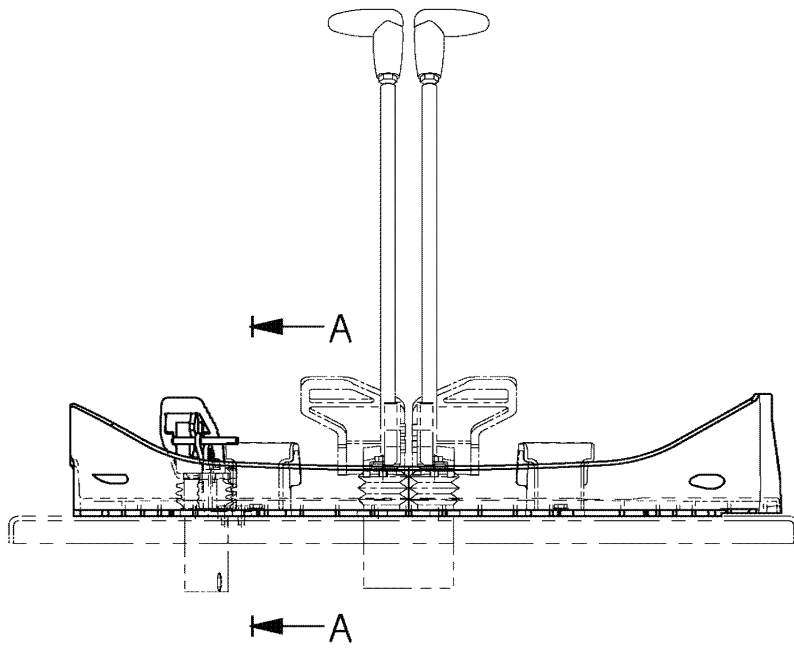
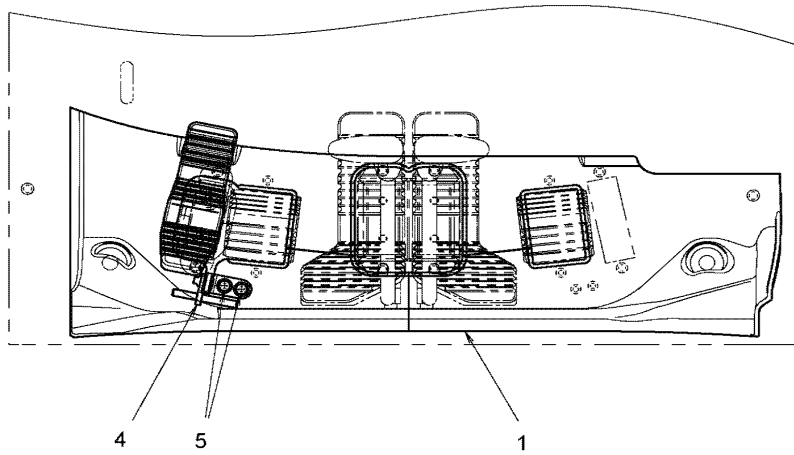

DC06J048

1.039

00

p3

4/2021

CONTROL LINES, MAIN (ROTATION NIBBLER & BREAKER) (YN06H00089F1)

| REF FN | PART NUMBER | YR/SN | QTY DESCRIPTION |
|--------|----------------------------|-------|--|
| A17 | 2444Z2336 ZD12P01100 | | 2 TEE PF 1/4" x 3/8" x 3/8" Tee -- (Incls. O-Ring ZD12P01100) 1 O-RING 10.8mm ID x 15.6mm OD x 2.4mm Thk (Part of 2444Z2336), ID 10.80 ± 0.18 x OD 15mm, Not Shown |
| A18 | HH55Q06006G1 ZD12P01400 | | 2 TEE PF 3/8" x PF 3/8" x PF 3/8" (Incls. O-Ring ZD12P01400) 1 O-RING 13.8mm ID x 18.6mm OD x 2.4mm Thk (Part of HH55Q06006G1), ID 13.80 ± 0.19 x OD 18mm, Not Shown |
| A19 | YN06H01046P1 | | 1 TEE PF 3/8" x PF 3/8" x PF 1/4" Tee -- (2) 3/8" PF x 1/4" PF x 56mm Long -- Replaces 2444Z3421 |
| A20 | 2444T3402 237-6004 | | 1 TEE PF 3/8" x PF 3/8" x PF 3/8" Tee -- (Incls. O-Ring 237-6004) 1 O-RING 0.072" Thk x 0.351" ID, -904, CI 6, 90 Duro (Part of 2444T3402), SAE NO. 4-1, Not Shown |
| A21 | YN06H01045P1 ZD12P01100 | | 1 45 ELBOW PF 1/4" x PF 1/4" Elbow, 45° -- (2) 1/4" PF x 50mm Long (Incls. O-Ring ZD12P01100) 1 O-RING 10.8mm ID x 15.6mm OD x 2.4mm Thk (Part of YN06H01045P1), ID 10.80 ± 0.18 x OD 15mm, Not Shown |
| A22 | ZH42X06000 ZD12P01400 | | 2 45 ELBOW Male, 30 Degree Fl, PF 3/8" x PF 3/8", O-Ring 45° -- (Incls. O-Ring ZD12P01400) 1 O-RING 13.8mm ID x 18.6mm OD x 2.4mm Thk (Part of 2444Z2891), ID 13.80 ± 0.19 x OD 18mm, Not Shown |
| A23 | 2444Z2891 ZD12P01400 | | 1 HYD CONNECTOR PF 3/8" x PF 3/8" x 35mm L (Incls. O-Ring ZD12P01400) 1 O-RING 13.8mm ID x 18.6mm OD x 2.4mm Thk (Part of 2444Z2891), ID 13.80 ± 0.19 x OD 18mm, Not Shown |

E215B-CRAWLER EXCAVATOR - TIER 3 (NA) - ASN N7DA21001

CONTROL LINES, PROPEL (YN62H00029F1 & YN64H00183F1)

| REF FN | PART NUMBER | YR/SN | QTY DESCRIPTION |
|--------|--------------|-------|--|
| | ⌋ | | Propel Control Lines, YN62H00029F1, Incls. Refs. A1-A13 |
| A1 | YN30V00105F1 | | 1 PILOT VALVE Assembly, Pilot -- See Figure 8.040 |
| A2 | 2420R349D085 | | 2 HOSE PF 1/4", 6.4mm ID x 10.4mm OD x 850mm L |
| A3 | 2420R349D155 | | 2 HOSE PF 1/4", 6.4mm ID x 10.4mm OD x 1550mm L |
| A4 | 2420R349D350 | | 1 FLEXIBLE HOSE PF 1/4", 6.4mm ID x 10.4mm OD x 3500mm L 3500mm Long (137-51/64 in) |
| A5 | 2420R349D370 | | 1 HOSE PF 1/4", 6.4mm ID x 10.4mm OD x 3700mm L 3700mm Long (145-43/64 in) |
| A6 | HH25X04004G2 | | 1 HYD CONNECTOR PF 1/4" x PF 1/4" x 36mm L (Incls. O-Ring ZD12P01100) |
| | ZD12P01100 | | 1 O-RING 10.8mm ID x 15.6mm OD x 2.4mm Thk (Part of HH25X04004G2), ID 10.80 ± 0.18 x OD 15mm, Not Shown |
| A7 | ZH22X04006 | | 1 HYD CONNECTOR Male, 30 Deg Fl, PF 3/8" x PF 1/4" x 36mm L, O-Ring (Incls. O-Ring ZD12P01400) |
| | ZD12P01400 | | 1 O-RING 13.8mm ID x 18.6mm OD x 2.4mm Thk (Part of ZH22X04006), ID 13.80 ± 0.19 x OD 18mm, Not Shown |
| A8 | ZH32X04006 | | 4 90 ELBOW Male, 30 Degree Fl, PF 1/4" x PF 3/8", O-Ring 90° -- (Incls. O-Ring ZD12P01400) |
| | ZD12P01400 | | 1 O-RING 13.8mm ID x 18.6mm OD x 2.4mm Thk (Part of ZH32X04006), ID 13.80 ± 0.19 x OD 18mm, Not Shown |

E215B-CRAWLER EXCAVATOR - TIER 3 (NA) - ASN N7DA21001

1.049

00

p1

4/2021

CAB INSTALLATION (YN02C00151F1)

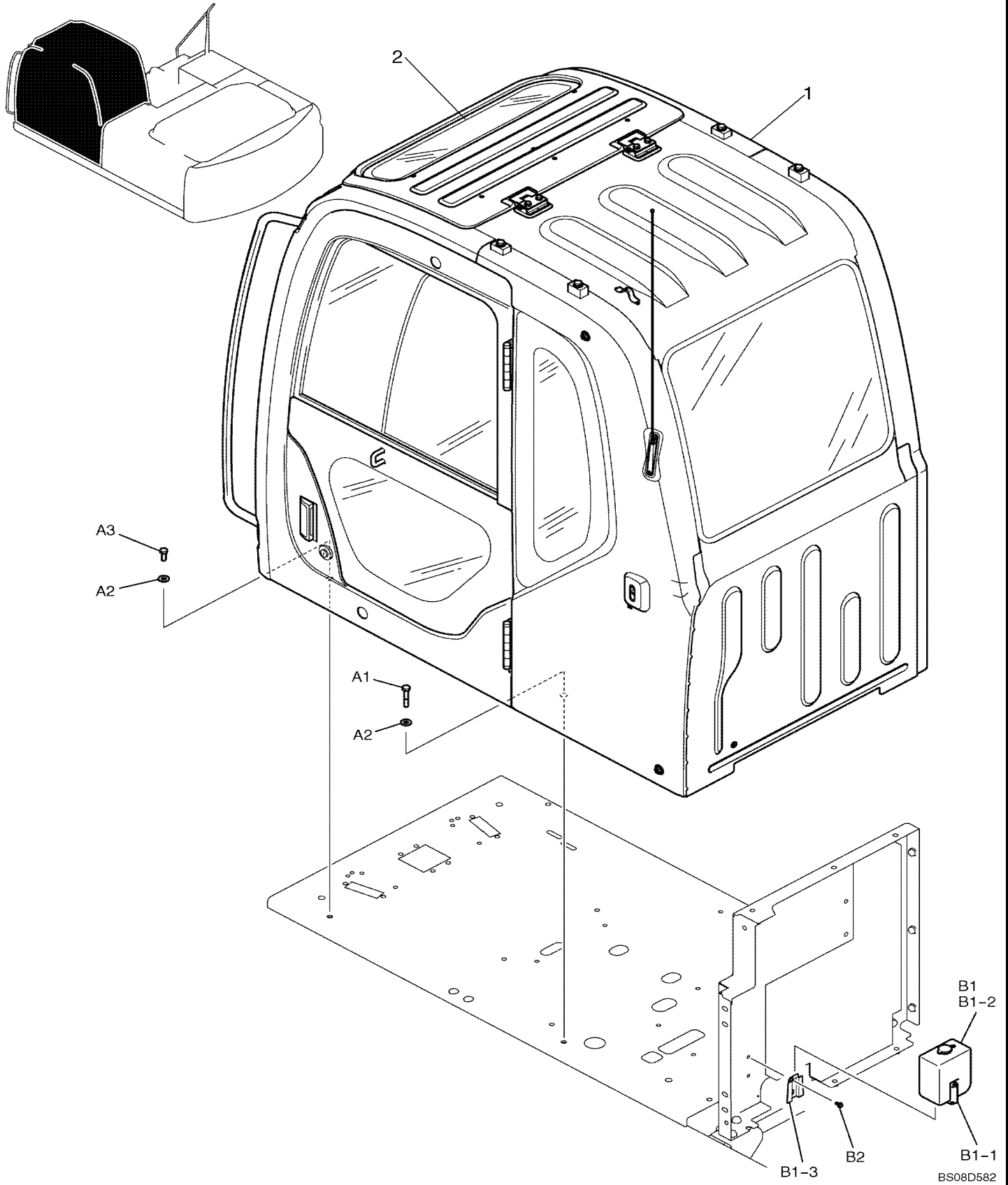

CAB ASSEMBLY, (YN02C00179F1), USED FROM DATE 05/19/2006 - 06/09/2006, FIGURE 2 OF 3

| REF FN | PART NUMBER | YR/SN | QTY DESCRIPTION |
|--------|----------------|-------|---|
| . | { } | | Cab Assembly, YN02C00179F1, Figure 2 of 3 |
| . | { } | | Cab Assembly, YN02C00179F1, Used from date 05/19/2006 - 06/09/2006 |
| . | { } | | Cab Assembly, YN02C00179F1, Incls. Refs. 1-122 |
| 3 | YN50C00005F1 | | 1 WINDOW Assembly, Front |
| 4 | YN02C03160P1 | | 1 GLASS 832mm W x 389mm H, W/ Rounded Lwr Corners Lower Front |
| 7 | YN02C01787P1 | | 1 GLASS |
| 9 | YN02C03006P2 | | 1 GASKET Replaces YN02C03006P1 |
| 12 | YT02C01115D3 | | 1 RUBBER SLEEVE |
| 16 | YN02C03887P1 | | 2 STOP Replaces YN02C03004P2 |
| 17 | YN02C02747P1 | | 1 GUIDE |
| 18 | YN02C02746P1 | | 1 GUIDE |
| 19 | YN02C03005P1 | | 4 SPACER |
| 29 | YT02C01136P1 | | 2 STOP Replaces YN02C03144P1 |
| 49 | YN02C03098P1 | | 1 HARNESS |
| 52 | YT80S00001P1 | | 1 LIGHT |
| 55 | YN53C00012F2 | | 1 WIPER MOTOR Motor Assembly only -- No service parts |
| 56 | YN53C01003F1 | | 1 WIPER ARM -- is a complete arm & wiper assembly, Assy, Incl 56-1 - 56-6 |
| 56-1 | YN53C01003S001 | | 1 WIPER ARM -- is just the wiper arm, 505.6mm Long (19-29/32 in) |
| 56-2 | YN53C01003S002 | | 1 WIPER BLADE -- is just the wiper blade, 600mm Long (23-5/8 in) |
| 56-3 | YN53C01003S003 | | 2 SCREW |
| 56-4 | YN53C01003S004 | | 1 COVER |
| 56-5 | YN53C01003S005 | | 1 STOP |
| 56-6 | YN53C01003S006 | | 2 BRACKET |
| 57 | YN02C01294P1 | | 1 STOP |
| 61 | 2420Z1227D4 | | 3 SCREW M6 x 1.0 x 20mm M06x1.0x20mm |

E215B-CRAWLER EXCAVATOR - TIER 3 (NA) - ASN N7DA21001

1.051

01

p3

4/2021

CAB ASSEMBLY (YN02C00149F1), USED FROM DATE 03/10/2006 - 05/19/2006 & 06/09/2006 - UP, FIGURE 1 OF 3

LY01-00101-

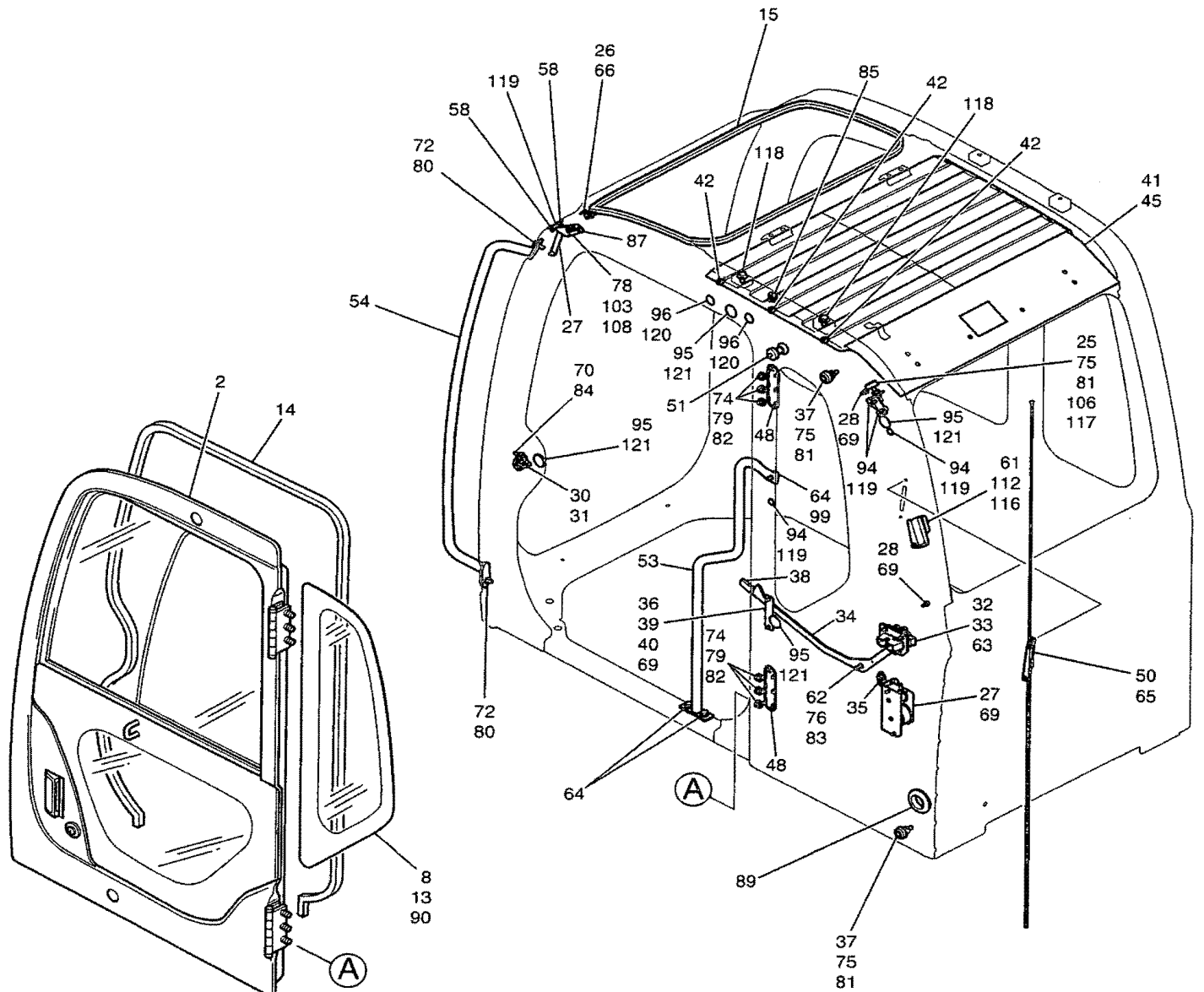
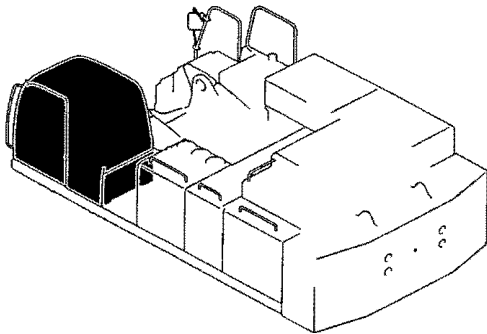

1.052

00

p1

4/2021

WINDOW, ROOF (YN02C03183F1), USED FROM DATE 03/10/2006 - 05/19/2006

| REF FN | PART NUMBER | YR/SN | QTY DESCRIPTION |
|--------|--------------|-------|---|
| | YN02C03183F1 | | AR WINDOW Roof Assembly, Incls. Refs. 1-28, Used from date 03/10/2006 - 05/19/2006 |
| 1 | YN02C03627P1 | | 1 ROOF Roof, Replaces YN02C03188P2 |
| 2 | YN02C03810F1 | | 2 LOCK Replaces YN02C03032P1 |
| 3 | YT02C01086P1 | | 2 GAS STRUT Replaces YN02C03032P1 |
| 4 | YN02C03664P1 | | 1 PLATE Plate, Replaces YN02C03473P1 |
| 5 | YN02C03640P1 | | 1 PLATE Plate, Replaces YN02C02705P1 |
| 6 | YN02C03471P1 | | 2 SPACER Spacer, Replaces YN02C03184P1 |
| 7 | YN02C03187P2 | | 2 PLATE Replaces YN02C03187P1 |
| 8 | YN02C03194P1 | | 2 HINGE |
| 9 | ZM73C08025 | | 4 BOLT M8 x 1.25 x 25mm - Course Thread M08x1.25x25mm (Incls. Washer) |
| 10 | ZM66C06025 | | 8 BOLT M6 x 1.0 x 25mm M06x1.0x25mm (Incls. Washer & Lockwasher), Replaces ZM66C06030 |
| 11 | ZM66C06020 | | 4 BOLT M6 x 1.0 x 20mm M06x1.0x20mm (Incls. Washer & Lockwasher) |
| 12 | ZS18C08020 | | 4 SCREW Hex, M8 x 1.25 x 20mm M8 x 1.25 x 20 |
| 13 | YR21C01161P1 | | 4 WASHER 9mm ID x 22mm OD x 2.3mm Thk ID 09 x OD 22 x Th 2.3mm |
| 14 | ZM73C06016 | | 4 BOLT M6 x 1.0 x 16mm - Course Thread M06x1.0x16mm (Incls. Washer) |
| 15 | YN02C02967P1 | | 1 HANDLE |
| 16 | {ZN45C06012} | | 14 Nut, M06x1.0mm |
| 17 | YT02C01390P1 | | 4 WASHER 9mm ID x 20mm OD x 0.8mm Thk ID 09 x OD 20 x Th 0.8mm |
| 18 | ZR36X00600 | | 4 SNAP RING 6mm ID x 12mm OD x 0.8mm Thk Shaft 06mm x OD 12mm |
| 19 | ZS31C06020 | | 2 SCREW Phillips Drive, Pan HD, M6 x 20mm M06x1.0x20mm |
| 20 | ZW16K06000 | | 2 WASHER 6mm ID x 11mm OD x 1.6mm Thk |

E215B-CRAWLER EXCAVATOR - TIER 3 (NA) - ASN N7DA21001

1.054

00

p1

4/2021

WINDOW ASSEMBLY, FRONT (YN50C00005F1)

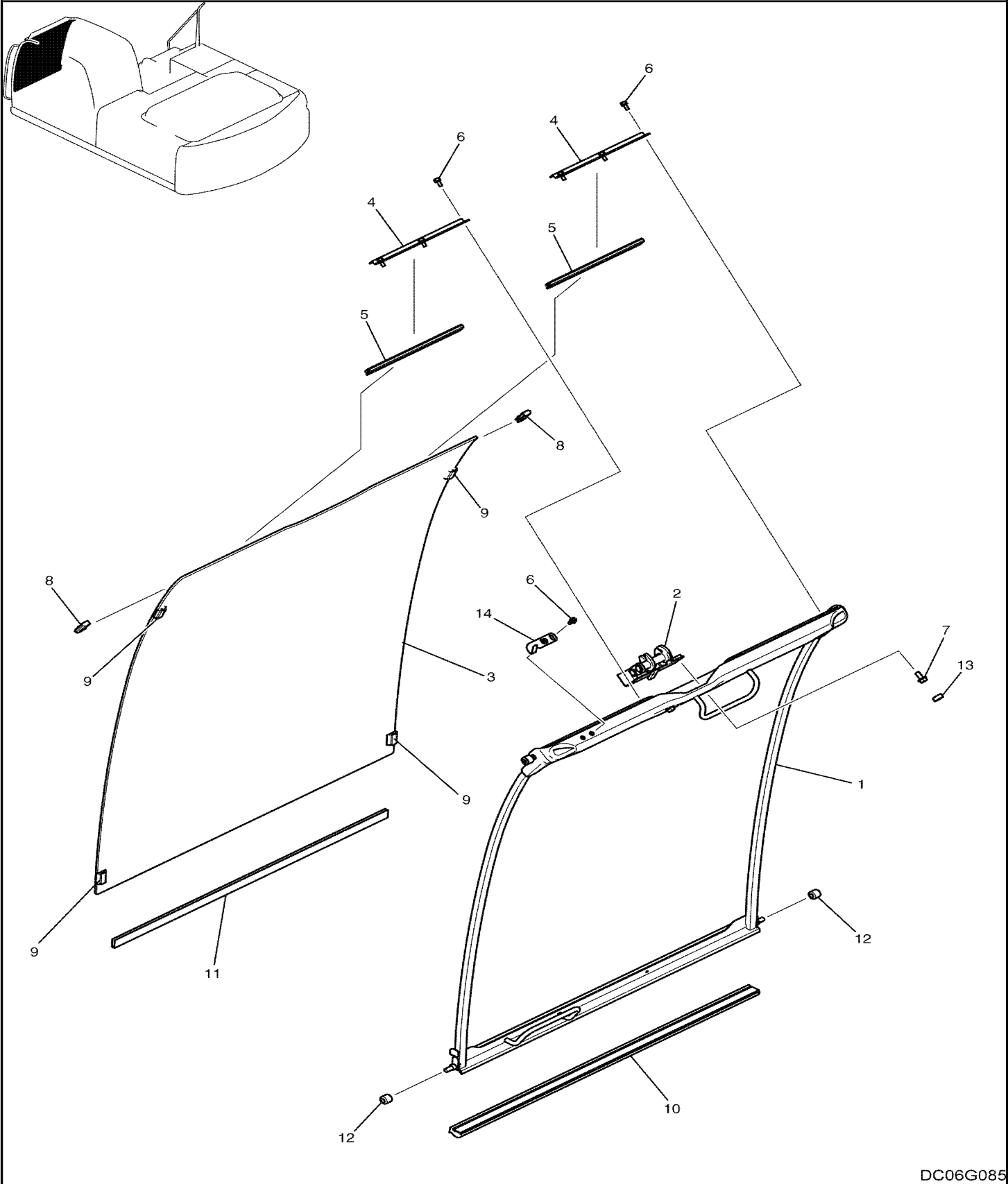

1.056

00

p2

4/2021

CAB DOOR, (YN51C00010F2), FIGURE 2 OF 2

| REF FN | PART NUMBER | YR/SN | QTY DESCRIPTION |
|--------|--------------|-------|---|
| 20 | ZS41C06016 | | 3 SCREW M6 x 1.0 x 16mm M06x1.0x16mm |
| 21 | YN51C01030P1 | | 2 RUBBER |
| 22 | YN51C01054P1 | | 2 RUBBER SLEEVE |
| 23 | YN51C01053P1 | | 2 RUBBER |
| 24 | YN51C01040P1 | | 3 HOLDER 7.6mm H x 12.5mm W x 25.3mm L |
| 25 | YN51C01016P1 | | 1 ROD |
| 26 | YN51C01015P1 | | 1 ROD |
| 27 | ZN18C08007 | | 2 NUT M8 x 1.25 M08x1.25mm |
| 28 | YT51C01068P1 | | 2 WASHER 8.1mm ID x 15.5mm OD x 2.5mm Thk ID 08.1 x OD 15.5 x Th 2.5mm |
| 29 | ZW26X08000 | | 2 LOCK WASHER 8mm ID x 15mm OD x 2.0mm Thk Lock -- ID 08 x OD 15 x Th 2.0mm |
| 30 | YN51C01031P1 | | 2 RUBBER SLEEVE |
| 31 | ZM27C10025 | | 2 BOLT M10 x 1.50 x 25mm M10x1.50x25mm (Incls. Washer & Lockwasher) |
| 32 | YN17M01033D3 | | 1 SCREW M5 x 10mm M05x10mm |
| 33 | YT02C01295D2 | | 1 RUBBER |
| 34 | YT02C01230P1 | | 3 WASHER 6.4mm ID x 12mm OD x 0.5mm Thk Star Lock -- ID 06.40 ± 0.30 x OD 12 x Th 0.5mm |
| 35 | YN51C01095F1 | | 1 LINK ASSY. |
| 35-1 | YT51C01027P1 | | 1 LOCK |
| 35-2 | YN51C01024P1 | | 1 LINK |
| 35-3 | YN51C01014P1 | | 1 ROD |
| 35-4 | YN51C01013P1 | | 1 ROD |
| 35-5 | YN51C01018P1 | | 1 PLATE |
| 35-6 | YN51C01094P1 | | 1 ROD |
| 35-7 | YT51C01017P1 | | 3 PIN 5mm OD x 21.5mm L |
| 35-8 | YN51C01032P1 | | 3 HOLDER |
| 35-9 | YT51C01016P1 | | 1 PIN |

E215B-CRAWLER EXCAVATOR - TIER 3 (NA) - ASN N7DA21001

1.059

01

p2

4/2021

GUARD INSTALLATION, (COMMON) (YN21C00098F1), FIGURE 1 OF 2

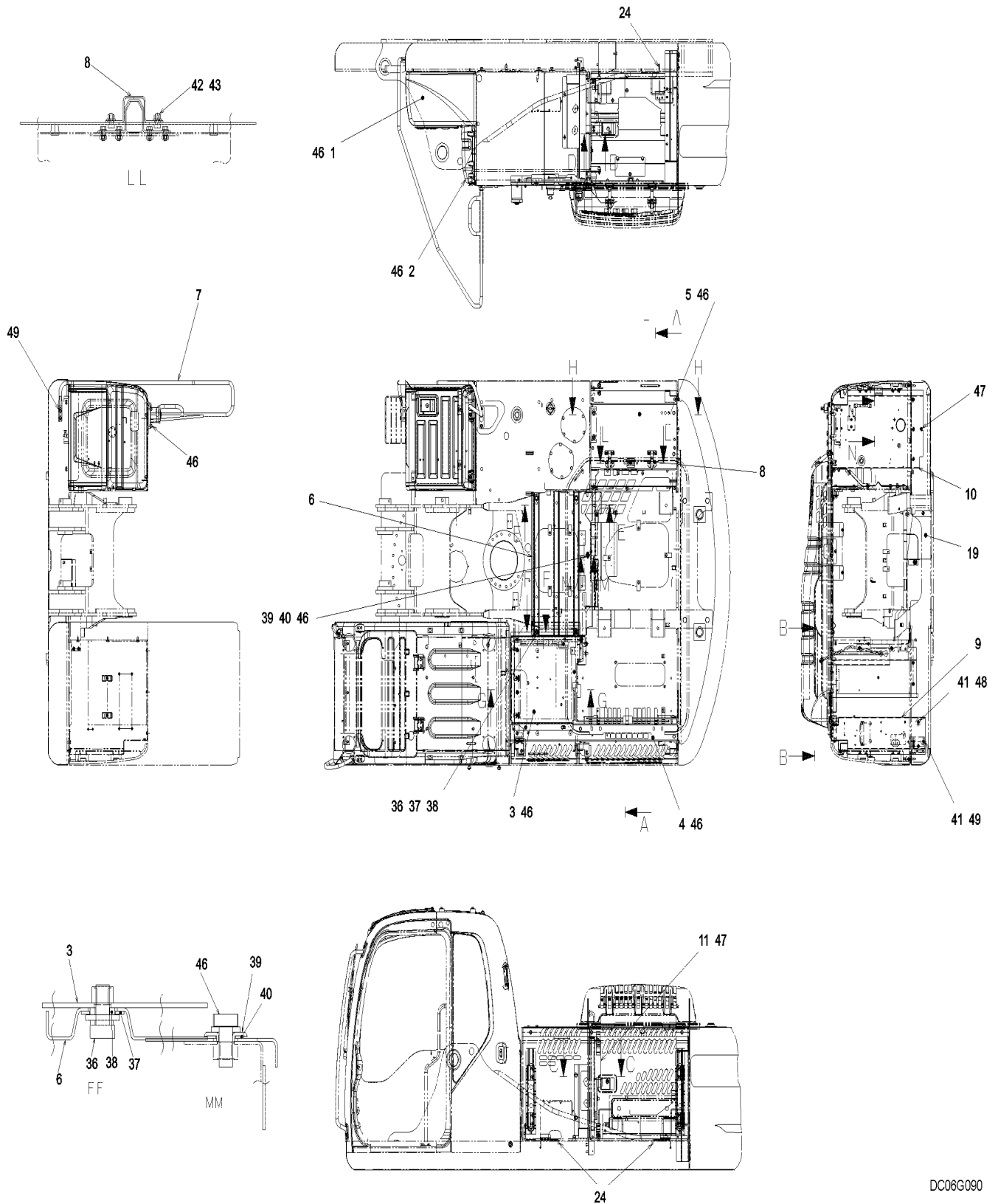

1.060

00

p1

4/2021

GUARD ASSEMBLY (TOOL BOX) (YN21C03063F1)

| REF FN | PART NUMBER | YR/SN | QTY DESCRIPTION |
|--------|--------------|-------|--|
| . | ⌋ | | Guard Assembly (Tool Box), YN21C03063F1 |
| 1 | YN21C03354P3 | | 1 TOOL BOX Top Opening, |
| 2 | YN21C03023P1 | | 1 COVER |
| 3 | YN21C02821P1 | | 1 STAY Stay |
| 4 | ZW16P06000 | | 1 WASHER 6mm ID x 12mm OD x 1.6mm Thk ID 06 x OD 11.5 x Th 1.6mm |
| 5 | 2419R9D1 | | 1 PIN 1.2mm OD x 21.2mm L ND 06mm x 21.2mm Long |
| 6 | YJ21C01079D1 | | 3 WEATHERSTRIP 9.5mm W x 27.5mm H x 95mm L Weatherstrip -- 95mm Long (3-3/4 in) |
| 7 | YN21C01724DC | | 2 TRIM 10mm W x 15mm H x 100mm L Trim -- 100mm Long (3-15/16 in) |
| 8 | ZM73C12025 | | 2 BOLT M12 x 1.75 x 25mm - Course Thread M12x1.75x25mm (Incls. Washer) |
| 9 | YN21C03253D1 | | 2 SPACER Trim -- 395mm Long (15-35/64 in) |
| 10 | YN21C03253D2 | | 1 SPACER Trim -- 625mm Long (24-39/64 in) |

E215B-CRAWLER EXCAVATOR - TIER 3 (NA) - ASN N7DA21001

1.065

01

p2

4/2021

INSTRUMENT PANEL ASSEMBLY (YN17M00063F1), FIGURE 1 OF 3

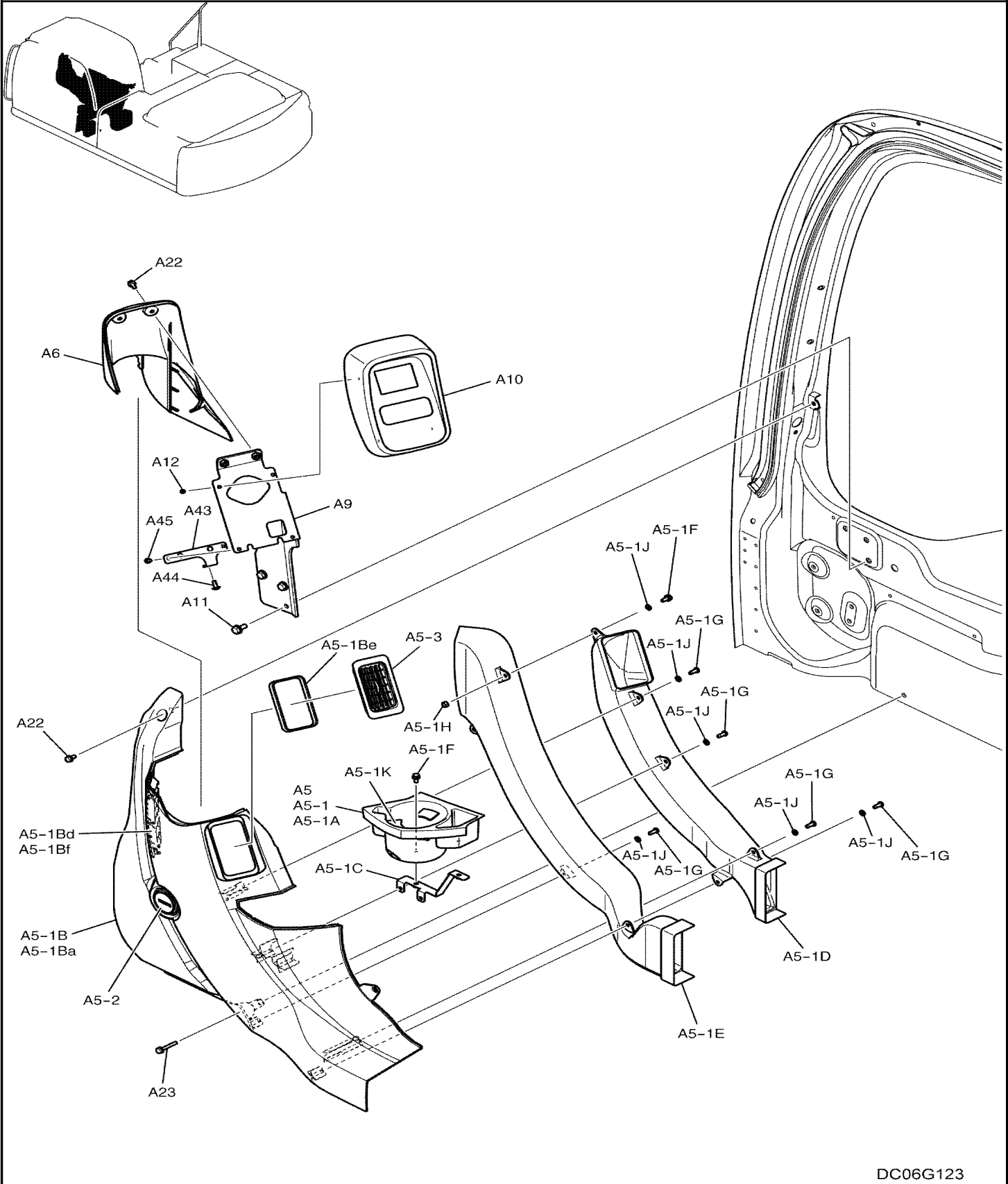

INSTRUMENT PANEL ASSEMBLY (YN17M00063F1), FIGURE 3 OF 3

| REF FN | PART NUMBER | YR/SN | QTY DESCRIPTION |
|--------|----------------|-------|--|
| A16 | YN54S00006P1 | | 2 SPEAKER |
| A18 | YN20M01568P1 | | 2 GRILLE |
| A19 | YN20M01628F1 | | 1 DUCT Assembly -- Incls. Refs. A19-1 - A19-5 |
| A19-1 | YN20M01630P1 | | 1 DUCT |
| A19-2 | YN20M01631F1 | | 1 DUCT Assembly -- Incls. Refs. A19-2A & A19-2B |
| A19- | YN20M01632P1 | | 1 DUCT |
| A19- | YN20M01633P1 | | 1 FOAM INSULATION 6mm W x 8mm H x 550mm L |
| A19-3 | YN20M01634F1 | | 1 DUCT Assembly -- Incls. Refs. A19-3A - A19-3C |
| A19- | YN20M01635P1 | | 1 DUCT |
| A19-3B | YN20M01636P1 | | 1 FOAM INSULATION 6mm W x 8mm H x 485mm L 6x8x485mm Long (19-3/32 in) |
| A19-3C | YN20M01637P1 | | 1 FOAM INSULATION 6mm W x 8mm H x 410mm L 6x8x410mm Long (16-9/64 in) |
| A19-4 | {YN20M01684P1} | | 2 Clip |
| A19-5 | {YN20M01685P1} | | 2 Screw |
| A20 | YN20M01638F1 | | 1 DUCT Assembly -- Incls. Refs. A20-1 & A20-2 |
| A20-1 | YN20M01639F1 | | 1 DUCT Assembly -- Incls. Refs. A20-1A & A20-1B |
| A20- | YN20M01640P1 | | 1 DUCT |
| A20- | YN20M01641P1 | | 1 DUCT |
| A20-2 | YN20M01642P1 | | 1 FOAM INSULATION 104.5mm W x 10mm H x 300mm L 104.5x10x300mm Long (11-13/16 in) |
| A22 | ZM66C06016 | | 19 BOLT M6 x 1.0 x 16mm M06x1.0x16mm (Incls. Washer & Lockwasher) |
| A24 | ZM66C08016 | | 2 BOLT M8 x 1.25 x 16mm M08x1.25x16mm (Incls. Washer & Lockwasher) |
| A27 | YN17M01262P1 | | 12 SCREW Phillips Drive, Pan HD, M5 x 10mm M05x10mm Self-Taper |

E215B-CRAWLER EXCAVATOR - TIER 3 (NA) - ASN N7DA21001

1.071

00

p1

4/2021

BATTERY INSTALLATION (YN72E00013F1)

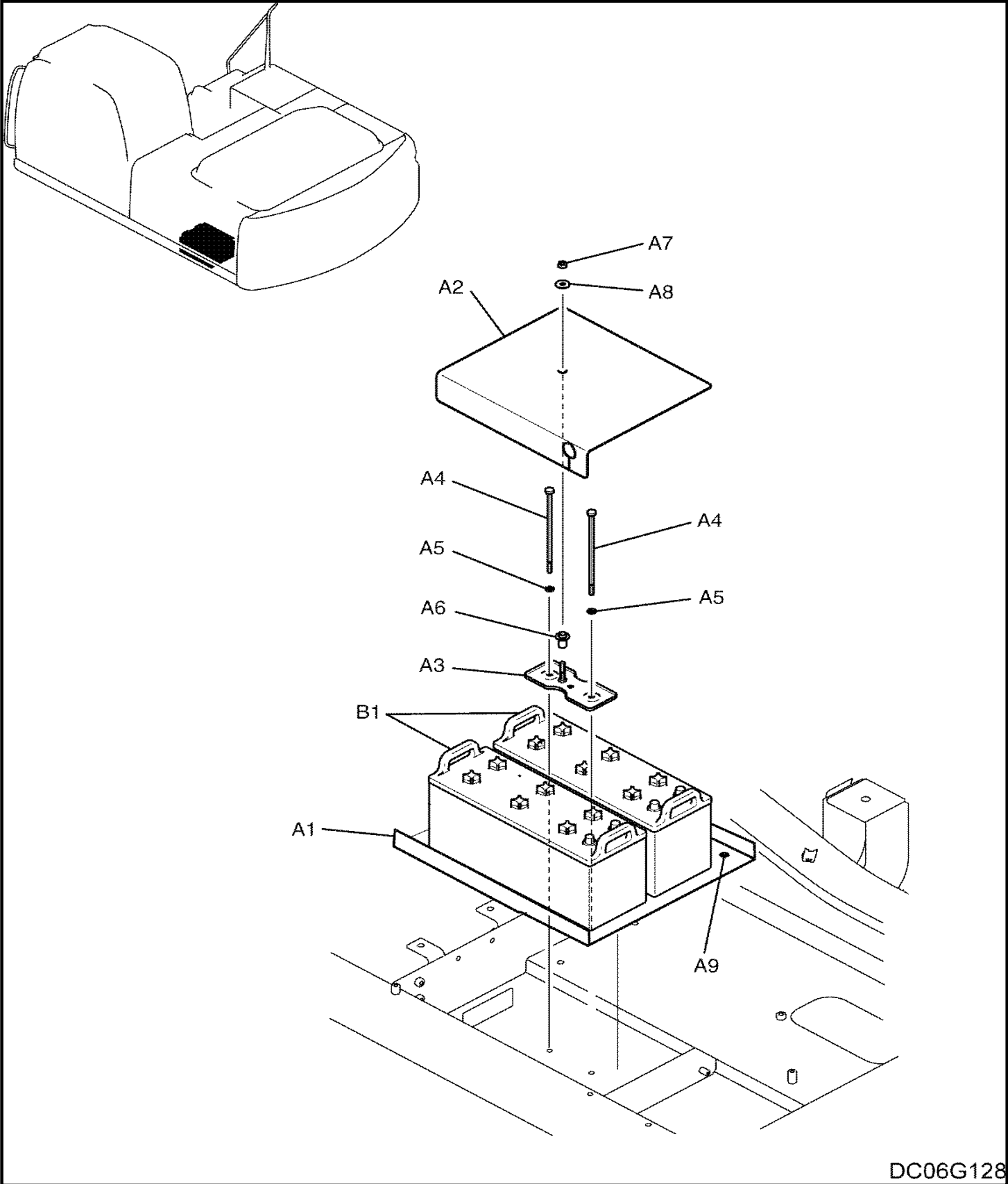

1.074

00

p1

4/2021

DRYER ASSEMBLY, AIR (YN96V00026F1)

| REF FN | PART NUMBER | YR/SN | QTY DESCRIPTION |
|--------|----------------|-------|--|
| | ∅ | | Air Dryer Assembly, YN96V00026F1 |
| 1 | YN54S00041P1 | | 1 RECEIVER-DRIER |
| 2 | YN20M01469P1 | | 1 BRACKET |
| 3 | YT96V00001S009 | | 2 SCREW M8 x 25mm Screw -- M08x25mm Long |
| 4 | YT96V00001S010 | | 2 SCREW M6 x 25mm Screw -- M06x25mm Long |
| 5 | YN20M01529F1 | | 1 FLEXIBLE HOSE 15.9mm ID x 24mm OD x 4200mm L (Incls. O-Ring 2445Z1604D5) |
| 5-2 | 2445Z1604D5 | | 2 O-RING (Part of YN20M01529F1), 5/8 in |
| 6 | YN20M01528F1 | | 1 FLEXIBLE HOSE 11.9mm ID x 19mm OD x 3184mm L (Incls. O-Ring 2445Z1604D4) |
| 6-2 | 2445Z1604D4 | | 2 O-RING (Part of YN20M01528F1), 1/2 in |
| 7 | YN20M01547F1 | | 1 FLEXIBLE HOSE 8.4mm ID x 15mm OD x 460mm L (Incls. O-Ring 2445Z1604D6) |
| 7-2 | 2445Z1604D6 | | 2 O-RING (Part of YN20M01547F1), 08mm |
| 8 | YN20M01617F1 | | 1 FLEXIBLE HOSE Hose = 3270mm L (Incls. O-Ring 2445Z1604D6) |
| 8-2 | 2445Z1604D6 | | 2 O-RING (Part of YN20M01617F1), 08mm |
| 10 | YN20M01518F1 | | 1 RIGID TUBE (Incls. O-Ring 2445Z1604D6) |
| 10-2 | 2445Z1604D6 | | 1 O-RING (Part of YN20M01518F1), 08mm |

E215B-CRAWLER EXCAVATOR - TIER 3 (NA) - ASN N7DA21001

1.078

00

p1

4/2021

ELEC ASSEMBLY, UPPER (YN03E00017F1)

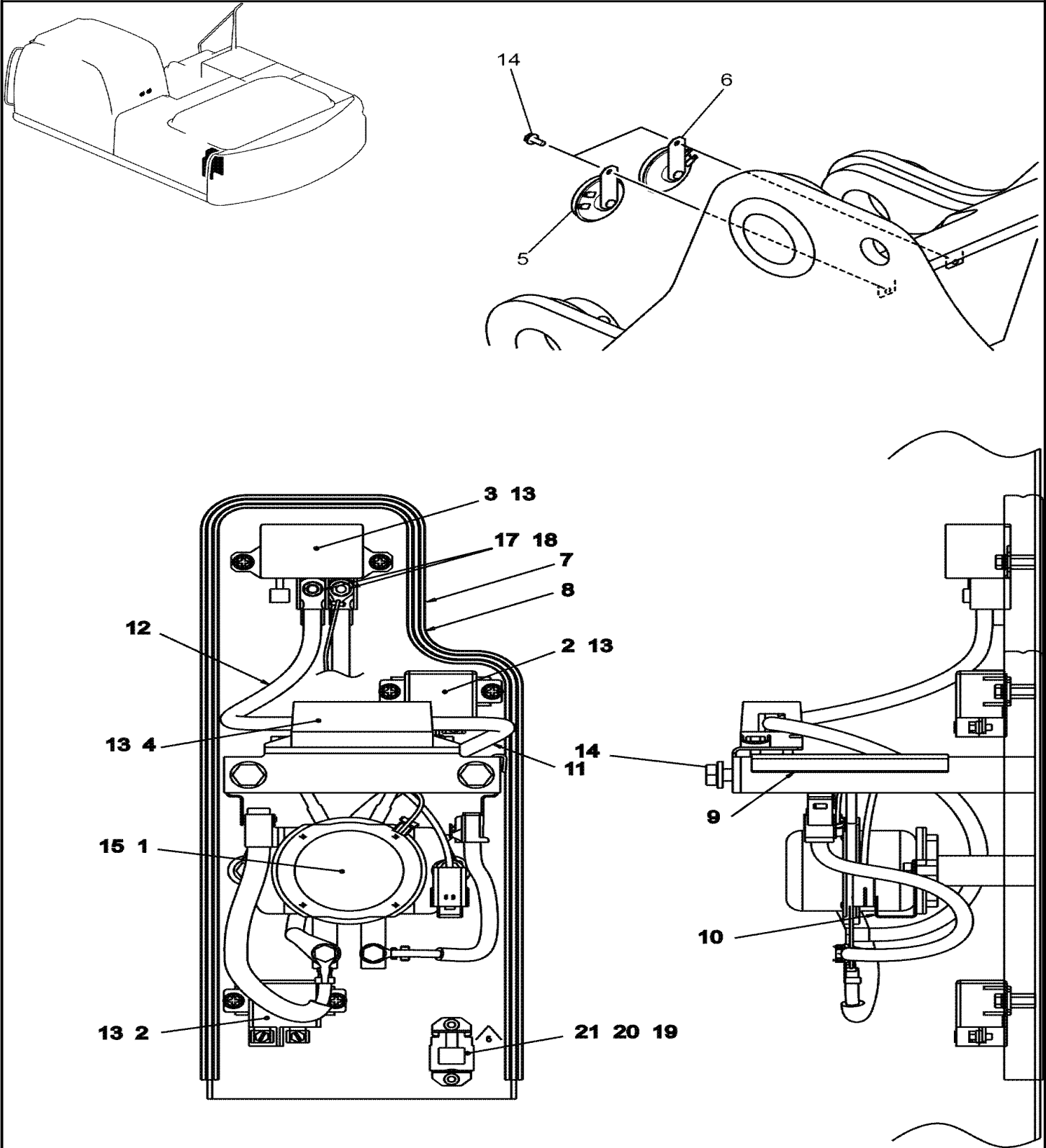

1.080

03

p1

4/2021

HARNESS ASSY, UPPER

| REF FN | PART NUMBER | YR/SN | QTY DESCRIPTION |
|--------|--------------|-------|--|
| 1 | LC13E01193P1 | | 1 HARNESS |
| 2 | EW02E01015D4 | | 6 CLAMP 10mm ID x 20mm W Clamp -- Ø10x20mm Long |
| 3 | EW02E01015D6 | | 1 CLAMP 16mm ID x 20mm W Clamp -- Ø15x22mm Long |
| 4 | EW02E01015D8 | | 3 CLAMP 18mm ID x 20mm W Clamp -- Ø18x24mm Long |
| 5 | EW02E01015D9 | | 5 CLAMP 20mm ID x 20mm W |
| 6 | EZ09H01066P1 | | 5 CLIP 32mm W x 95mm L x 26mm ID (x2) Clamp, Double -- Ø32x93mm Long |
| 7 | YN13E01375P1 | | 27 CLIP M8 x 8.20mm Shank Anchor Wire Ties |
| 8 | PY01P01043D3 | | 68 CABLE TIE 4.6mm W x 202mm L |
| 9 | ZM73C08020 | | 17 BOLT M8 x 1.25 x 20mm - Course Thread (Incls. Washer) |
| 10 | ZM73C10020 | | 8 BOLT M10 x 1.50 x 20mm - Course Thread (Incls. Washer) |
| 11 | ZW16H10000 | | 1 WASHER 11mm ID x 24mm OD x 3.2mm Thk ID 11 x OD 24 x Th 3.2mm |
| 12 | ZM73C08025 | | 1 BOLT M8 x 1.25 x 25mm - Course Thread (Incls. Washer) |

E215B-CRAWLER EXCAVATOR - TIER 3 (NA) - ASN N7DA21001

3.001

00

p1

4/2021

BOOM INSTALLATION, 5.65M (18FT 6IN) (YN02B00363F1), FIGURE 1 OF 2

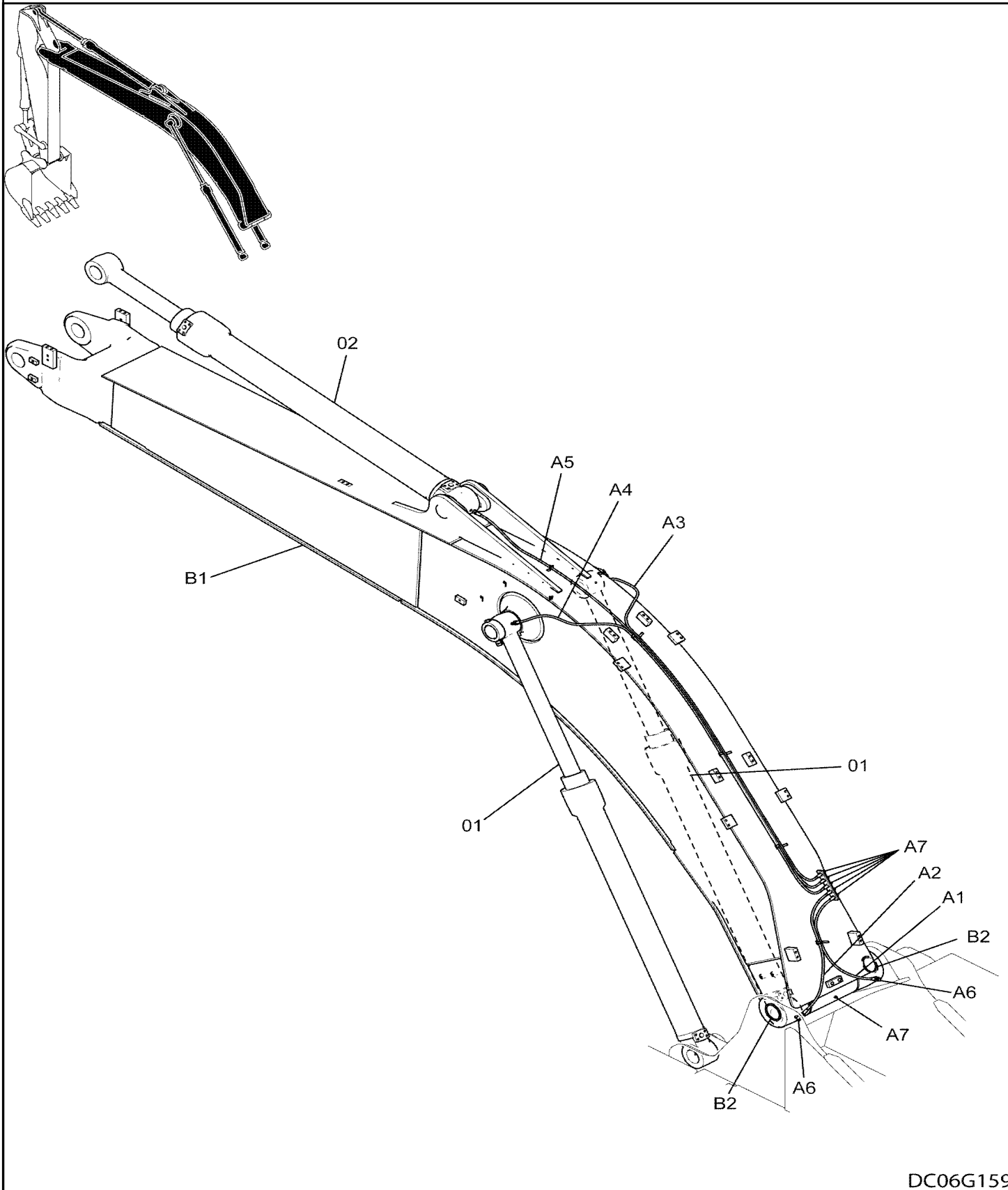

DC06G159

BOOM INSTALLATION, 5.65M (18FT 6IN) (YN02B00363F1), FIGURE 2 OF 2

| REF FN | PART NUMBER | YR/SN | QTY DESCRIPTION |
|--------|---------------|-------|--|
| 02 | YN01V00175F1 | | 1 CYLINDER Double Acting, 95mm Rod, 1558mm Stroke Assembly, Arm -- See Figure 8.023 |
| | YN01V00175F1R | | 1 REMAN-HYD CYLINDER Double Acting, 95mm Rod, 1558mm Stroke E215B TIER 3 (18FT 6IN) (YN02B00363F1) (1/07-) |
| | YN01V00175F1C | | CORE-HYD CYLINDER Double Acting, 95mm Rod, 1558mm Stroke Return Number |
| | ∅ | | Cylinder Installation, YN02B00367F1, Incls. Refs. E1-E7 |
| E1 | YN02B01722P1 | | 1 PIN 85mm OD x 277mm L |
| E2 | HS18C16150G2 | | 1 SCREW M16 x 2.0 x 150mm M16x2.0x150mm |
| E3 | ZN18C16013 | | 2 NUT M16 x 2.0 M16x2.0mm |
| E4 | B16T0442D78 | | 1 SHIM 87mm ID x 140mm OD x 0.5mm Thk ID 87 x OD 140 x Th 0.5mm |
| E5 | B16T0442D77 | | 1 SHIM 87mm ID x 140mm OD x 0.9mm Thk ID 87 x OD 140 x Th 0.9mm |
| E6 | B16T0442D62 | | 1 SHIM 87mm ID x 140mm OD x 1.6mm Thk ID 87 x OD 140 x Th 1.6mm |
| E7 | YN02B01417D1 | | 2 SHIM 87mm ID x 140mm OD x 2mm Thk ID 87 x OD 140 x Th 2.0mm |

E215B-CRAWLER EXCAVATOR - TIER 3 (NA) - ASN N7DA21001

3.004

00

p5

4/2021

HYDRAULIC LINES, BOOM (BASE + STD) (YN42H00328F1), FIGURE 1 OF 2

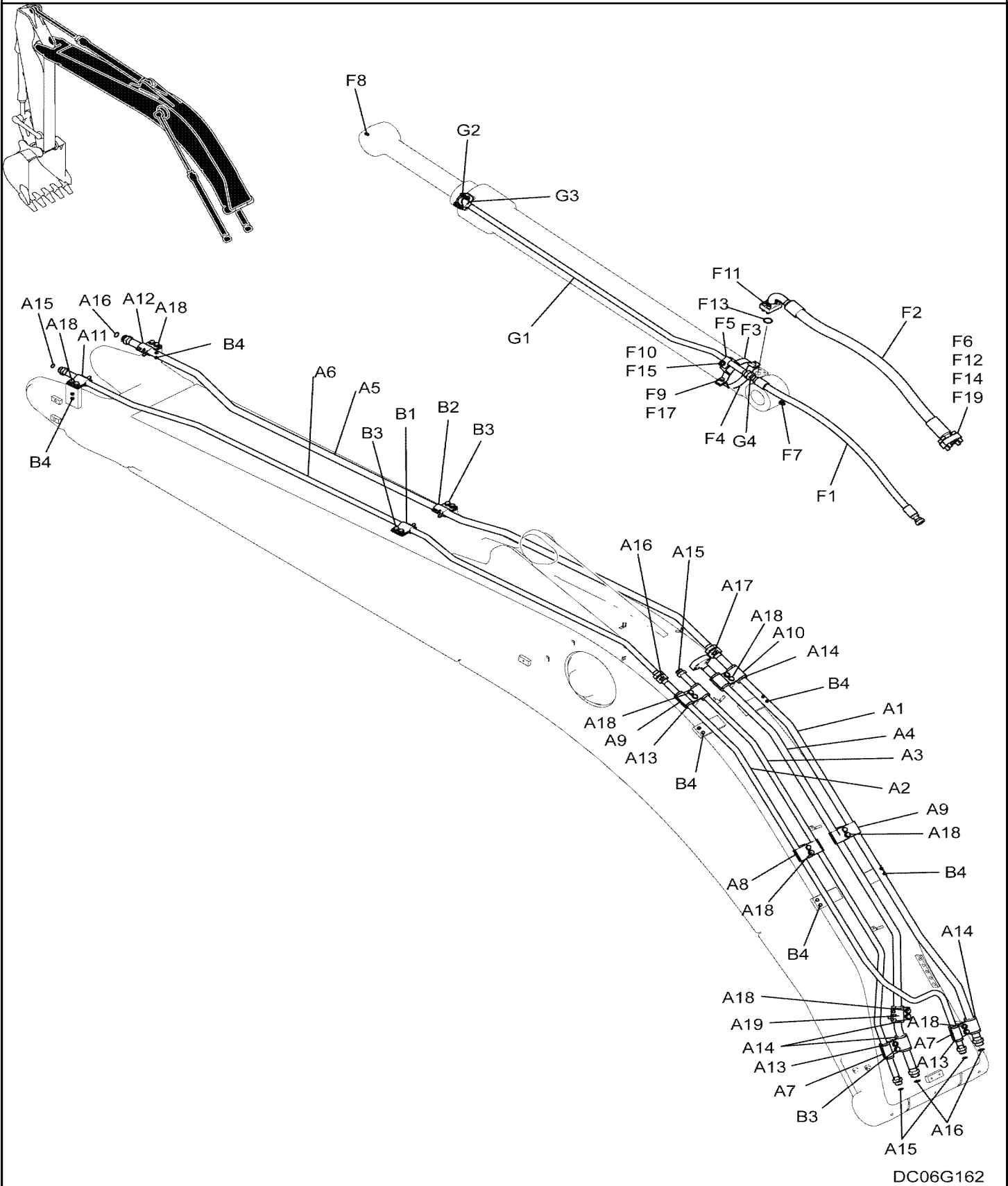

3.005

00

p4

4/2021

HYDRAULIC LINES, BOOM (BASE + STD) (YN42H00328F1), FIGURE 2 OF 2

| REF FN | PART NUMBER | YR/SN | QTY DESCRIPTION |
|--------|--------------|-------|---|
| E8 | HG23F04004G1 | | 2 HYD CONNECTOR PF 1/4" x 9/16 - 18 UNF X 33mm L 9/16" - 18UNS - 1/4"PF x 33mm Long (Incls. O-Ring ZD12P01100) |
| | ZD12P01100 | | 1 O-RING 10.8mm ID x 15.6mm OD x 2.4mm Thk (Part of HG23F04004G1), ID 10.80 ± 0.18 x OD 15mm, Not Shown |
| E9 | ZH32X06000 | | 2 90 ELBOW Male, 30 Degree Fl, PF 3/8" x PF 3/8", O-Ring Elbow, 90° -- (Incls. O-Ring ZD12P01400) Alternate O-Ring 237-6006 |
| | ZD12P01400 | | 1 O-RING 13.8mm ID x 18.6mm OD x 2.4mm Thk (Part of ZH32X06000), ID 13.80 ± 0.19 x OD 18mm, Not Shown |
| E10 | HH35X06006G3 | | 2 90 ELBOW Male, 30 Deg Fl, PF 3/8" x PF 3/8", O-Ring 90° -- 3/8"PFx3/8"PFx42.5mm Long (Incls. O-Ring ZD12P01400) |
| | ZD12P01400 | | 1 O-RING 13.8mm ID x 18.6mm OD x 2.4mm Thk (Part of HH35X06006G3), ID 13.80 ± 0.19 x OD 18mm, Not Shown |
| E11 | 2444Z3155 | | 2 90 ELBOW PF 3/8" Fem x PF 3/8" Male 90° -- (Incls. O-Ring ZD12P01400) Alternate O-Ring 237-6006 |
| | ZD12P01400 | | 1 O-RING 13.8mm ID x 18.6mm OD x 2.4mm Thk (Part of 2444Z3155), ID 13.80 ± 0.19 x OD 18mm, Not Shown |
| E12 | HH55Q06006G1 | | 2 TEE PF 3/8" x PF 3/8" x PF 3/8" (Incls. O-Ring ZD12P01400) |
| | ZD12P01400 | | 1 O-RING 13.8mm ID x 18.6mm OD x 2.4mm Thk (Part of HH55Q06006G1), ID 13.80 ± 0.19 x OD 18mm, Not Shown |
| E13 | ZD12P03400 | | 4 O-RING 33.7mm ID x 40.7mm OD x 3.5mm Thk ID 33.70 ± 0.33 x OD 40mm |
| E14 | ZD12A02100 | | 2 O-RING 23.52mm ID x 27.08mm OD x 1.78mm Thk ID 23.52 ± 0.15 x OD 27.08mm |

E215B-CRAWLER EXCAVATOR - TIER 3 (NA) - ASN N7DA21001

CLICK HERE TO **DOWNLOAD** THE COMPLETE MANUAL

- Thank you very much for reading the preview of the manual.
- You can download the complete manual from: www.heydownloads.com by clicking the link below



- Please note: If there is no response to CLICKING the link, please download this PDF first and then click on it.

CLICK HERE TO **DOWNLOAD** THE COMPLETE MANUAL

3.007

00

p3

4/2021

ARM INSTALLATION, 2.94M (9FT 8IN) (YN12B00810F1), FIGURE 1 OF 2

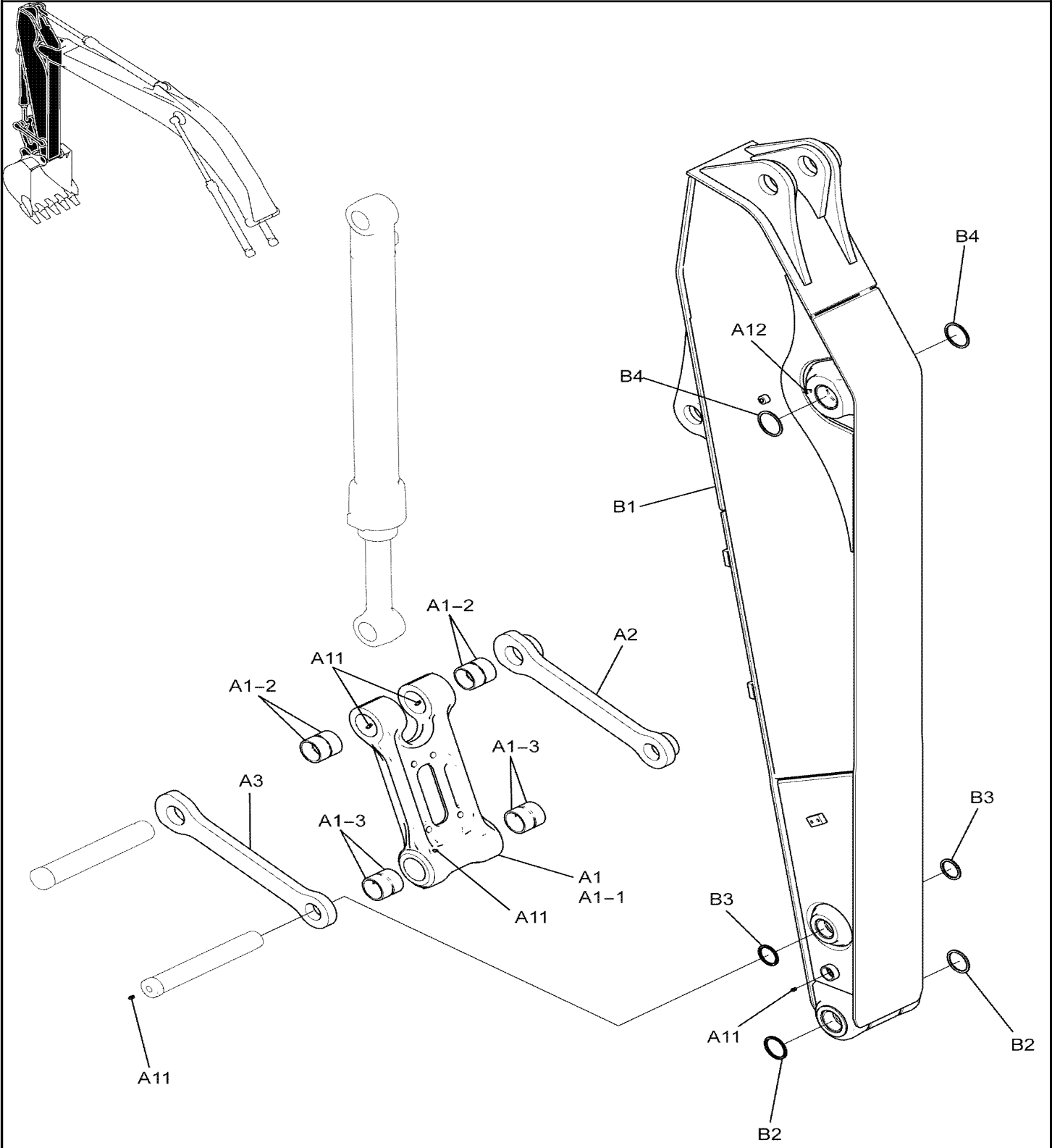

3.010

00

p1

4/2021

HYDRAULIC LINES - ARM (STANDARD) 2.94M (9FT 8IN) (YN43H00163F1)

| REF FN | PART NUMBER | YR/SN | QTY DESCRIPTION |
|--------|--------------|-------|--|
| . | { } | | Cylinder Installation (Standard) 2.94M (9ft 8in), YN12B00801F1 |
| . | { } | | Cylinder Installation, YN12B00654F1, Incls. Refs. A1-A7 |
| 0 | YN01V00153F1 | | 1 HYDRAULIC CYLINDER Bucket |
| A1 | YN12B02218P1 | | 1 PIN 80mm OD x 282mm L OD 80 x 252mm Long |
| A2 | HS18C16140G2 | | 1 SCREW M16 x 2.0 x 140mm M16x2.0x140mm |
| A3 | ZN18C16013 | | 2 NUT M16 x 2.0 M16x2.0mm |
| A4 | YN12B01601D1 | | 2 SHIM 82mm ID x 140mm OD x 2.0mm Thk ID 82 x OD 140 x Th 2.0mm |
| A5 | YN12B01122D1 | | 1 SHIM 82mm ID x 140mm OD x 0.5mm Thk ID 82 x OD 140 x Th 0.5mm |
| A6 | YN12B01122D2 | | 1 SHIM 82mm ID x 140mm OD x 0.9mm Thk ID 82 x OD 140 x Th 0.9mm |
| A7 | YN12B01122D3 | | 1 SHIM 82mm ID x 140mm OD x 1.6mm Thk ID 82 x OD 140 x Th 1.6mm |
| . | { } | | Cylinder Hydraulic Lines, YN43H00167F1, Incls. Refs. B1-B13 |
| B1 | YN43H01572P1 | | 1 TUBE 27.2 mm OD x 1262.5, 65 mm Length |
| B2 | YX42H01074P2 | | 1 BAND |
| B3 | YN43H01639P1 | | 1 BAND |
| B4 | YN43H01097P1 | | 1 CLAMP Single -- 58x30x38mm (Ø28mm) |
| B5 | ZG91S02000 | | 1 LUBE NIPPLE Straight, PT 1/8" 1/8" PT -- Straight |
| B6 | ZG91U02000 | | 1 LUBE NIPPLE 90 deg, PF 1/8" 90°x1/8" PT |
| B7 | ZD12P02600 | | 1 O-RING 25.7mm ID x 32.7mm OD x 3.5mm Thk ID 25.70 ± 0.26 x OD 32mm |
| B8 | ZD12A01800 | | 1 O-RING 18.77mm ID x 22.33mm OD x 1.78mm Thk ID 18.77 ± 0.12 x OD 22.33mm |

E215B-CRAWLER EXCAVATOR - TIER 3 (NA) - ASN N7DA21001

3.015

00

p1

4/2021

VALVE INSTALLATION (ROTATION) (YN64H00196F1)

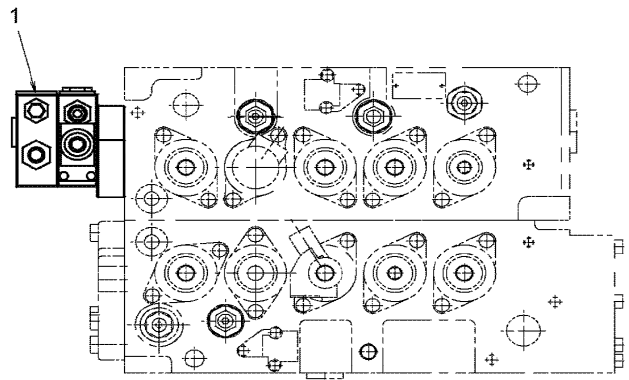
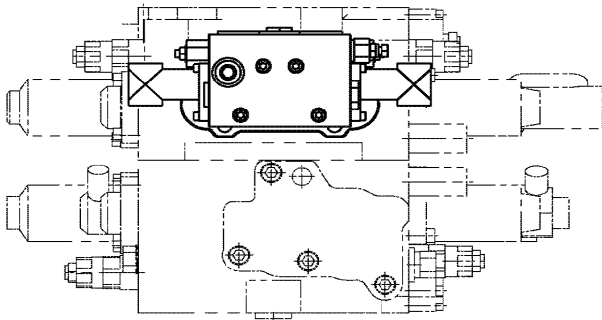
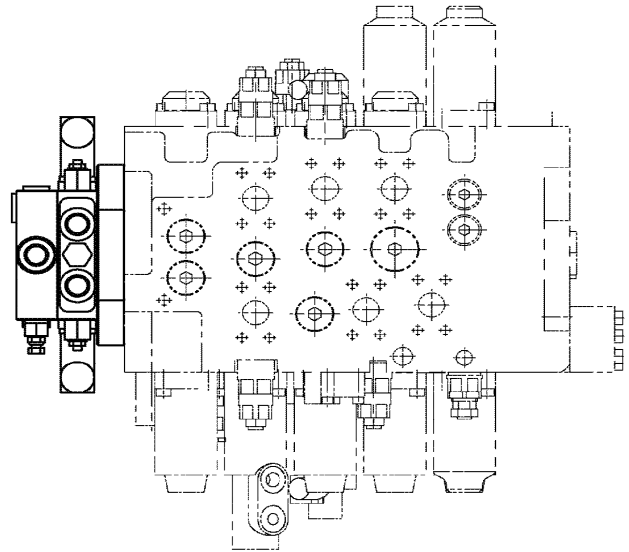

DC06J061

HYDRAULIC LINES, UPPER (NIBBLER & BREAKER) (YN03H00123F1)

| REF FN | PART NUMBER | YR/SN | QTY DESCRIPTION |
|--------|--------------------------|-------|---|
| | { } | | Upper Hydraulic Lines (Nibbler & Breaker), YN03H00123F1 |
| | { } | | Upper Hydraulic Lines, YN03H00125F1, See Figure 1.018 & 1.019 |
| | { } | | Upper Hydraulic Lines, YN03H00127F1, Incls. Refs. 1-15 |
| 1 | YN03H01806D1 | | 1 HYDRAULIC HOSE 25.4mm ID x 38.6mm OD x 1370mm L 1370mm Long (53-15/16 in) |
| 2 | YN03H01807D1 | | 1 HYDRAULIC HOSE 25.4mm ID x 38.6mm OD x 1480mm L 1480mm Long (58-17/64 in) |
| 3 | LQ03H01282D1 | | 1 HOSE 38mm ID x 47mm OD x 900mm L 900mm Long (35-7/16 in) |
| 4 | ZE12Q16000 ZD12P03400 | | 1 PLUG (Incls. O-Ring ZD12P03400) 1 O-RING 33.7mm ID x 40.7mm OD x 3.5mm Thk (Part of ZE12Q16000), ID 33.70 ± 0.33 x OD 40mm, Not Shown |
| 5 | ZE12X16000 | | 2 CLAMP Half -- (Incls. Capscrew & Lockwasher) |
| 6 | ZE13X20001 | | 4 CLAMP Half -- (Incls. Capscrew & Lockwasher) |
| 7 | ZS18C14045 | | 4 CAP Hex, M14 x 2.0 x 45mm Screw -- M14x2.0x45mm |
| 8 | ZS18C14050 | | 4 SCREW Hex, M14 x 2.0 x 50mm M14x2.0x50mm |
| 9 | HM83C10030G1 | | 4 BOLT M10 x 30mm M10x30mm |
| 10 | HM83C10035G1 | | 4 BOLT M10 x 35mm M10x35mm |
| 11 | HM83C12035G1 | | 4 BOLT M12 x 35mm M12x35mm |
| 12 | ZW26X14000 | | 8 LOCK WASHER 14mm ID x 24.5mm OD x 3.5mm Thk ID 14 x OD 24.5 x Th 3.5mm |
| 13 | ZD12P03400 | | 2 O-RING 33.7mm ID x 40.7mm OD x 3.5mm Thk ID 33.70 ± 0.33 x OD 40mm |

E215B-CRAWLER EXCAVATOR - TIER 3 (NA) - ASN N7DA21001

5.005

00

p3

4/2021

CONTROL LINES, VALVE (NIBBLER & BREAKER W/ROTATION) (YN64H00257F1)

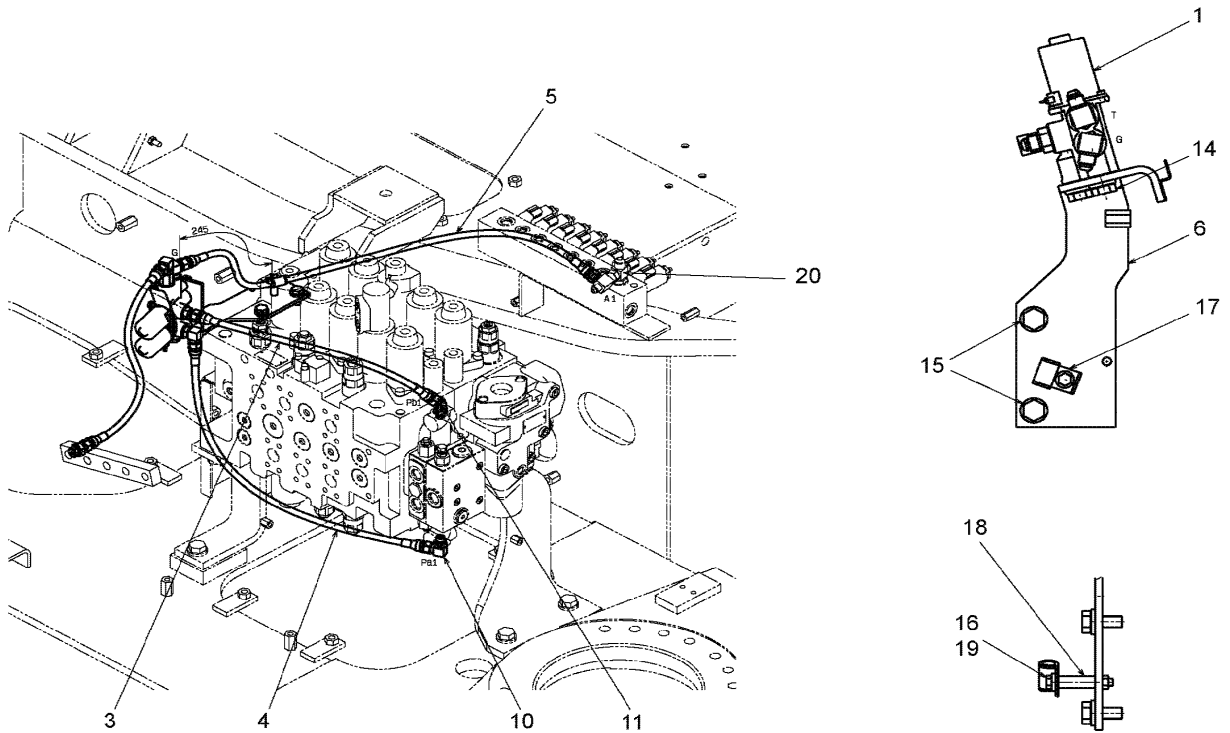
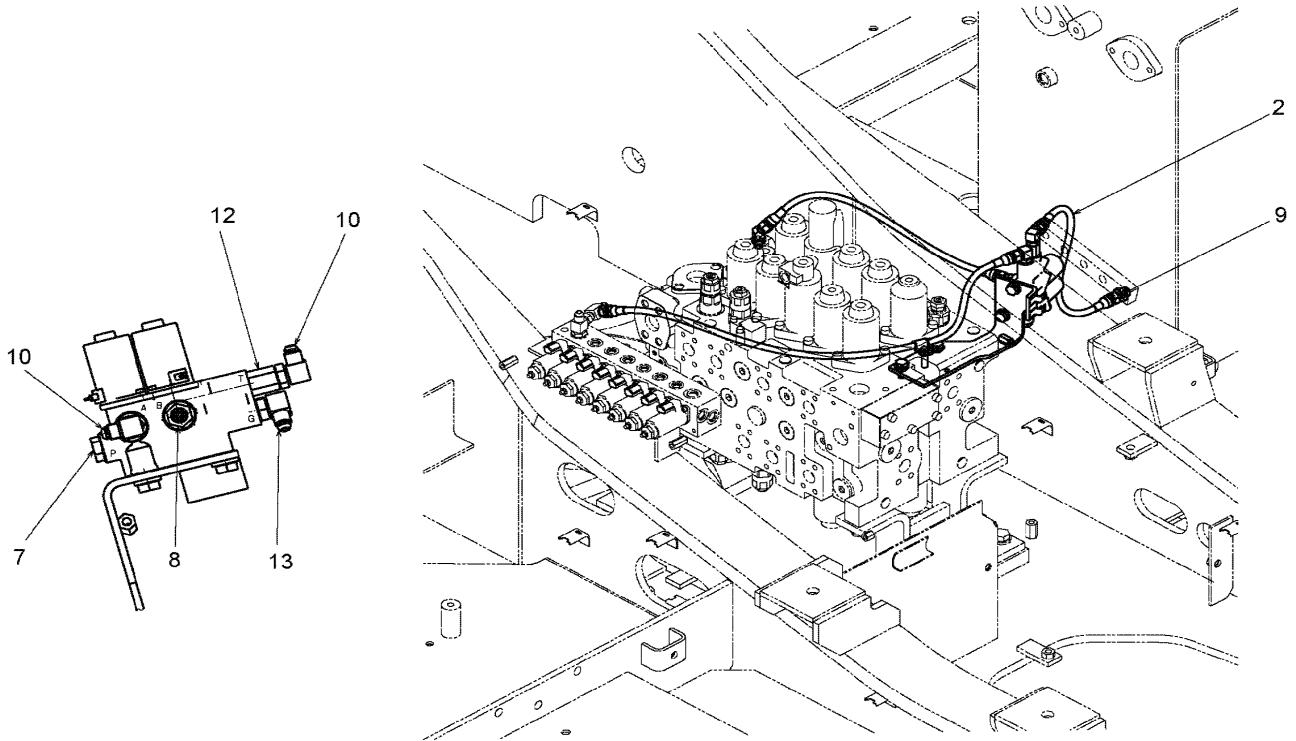

DC06J072

5.007

00

p2

4/2021

CONTROL LINES, MULTI (YN64H00289F1)

| REF FN | PART NUMBER | YR/SN | QTY DESCRIPTION |
|--------|--------------|-------|---|
| 11 | ZH32X06000 | | 1 90 ELBOW Male, 30 Degree Fl, PF 3/8" x PF 3/8", O-Ring Elbow, 90° -- (Incls. O-Ring ZD12P01400) Alternate O-Ring 237-6006 |
| | ZD12P01400 | | 1 O-RING 13.8mm ID x 18.6mm OD x 2.4mm Thk (Part of ZH32X06000), ID 13.80 ± 0.19 x OD 18mm, Not Shown |
| 12 | 2444Z2338 | | 1 90 ELBOW 1/4" PF x 3/8" PF 90° -- (Incls. O-Ring ZD12P01100) |
| | ZD12P01100 | | 1 O-RING 10.8mm ID x 15.6mm OD x 2.4mm Thk (Part of 2444Z2338), ID 10.80 ± 0.18 x OD 15mm, Not Shown |
| 13 | 2444Z3155 | | 2 90 ELBOW PF 3/8" Fem x PF 3/8" Male 90° -- (Incls. O-Ring ZD12P01400) Alternate O-Ring 237-6006 |
| | ZD12P01400 | | 1 O-RING 13.8mm ID x 18.6mm OD x 2.4mm Thk (Part of 2444Z3155), ID 13.80 ± 0.19 x OD 18mm, Not Shown |
| 14 | ZE72X04000 | | 4 PLUG PF 1/4" (Incls. O-Ring ZD12P01100) |
| | ZD12P01100 | | 1 O-RING 10.8mm ID x 15.6mm OD x 2.4mm Thk (Part of ZE72X04000), ID 10.80 ± 0.18 x OD 15mm, Not Shown |
| 15 | ZC47X14011 | | 2 CLIP CLIP |
| 16 | ZY26X06015 | | 1 SPACER |
| 17 | ZM73C08016 | | 4 BOLT M8 x 1.25 x 16mm - Course Thread M08x1.25x16mm (Incls. Washer) |
| 18 | ZM73C10025 | | 4 BOLT M10 x 1.50 x 25mm - Course Thread M10x1.50x25mm (Incls. Washer) |
| 19 | ZM73C10040 | | 1 BOLT M10 x 1.50 x 40mm - Course Thread M10x1.50x40mm (Incls. Washer) |
| 20 | YN64H01351P1 | | 1 GROMMET |
| 21 | YN21C03574P1 | | 1 COVER |
| | YN32TU1063FB | | KIT Pattern Change Field Kit |

E215B-CRAWLER EXCAVATOR - TIER 3 (NA) - ASN N7DA21001

5.012

00

p1

4/2021

CONTROL LINES, BLOCK (2 WAY) (YN64H00261F1)

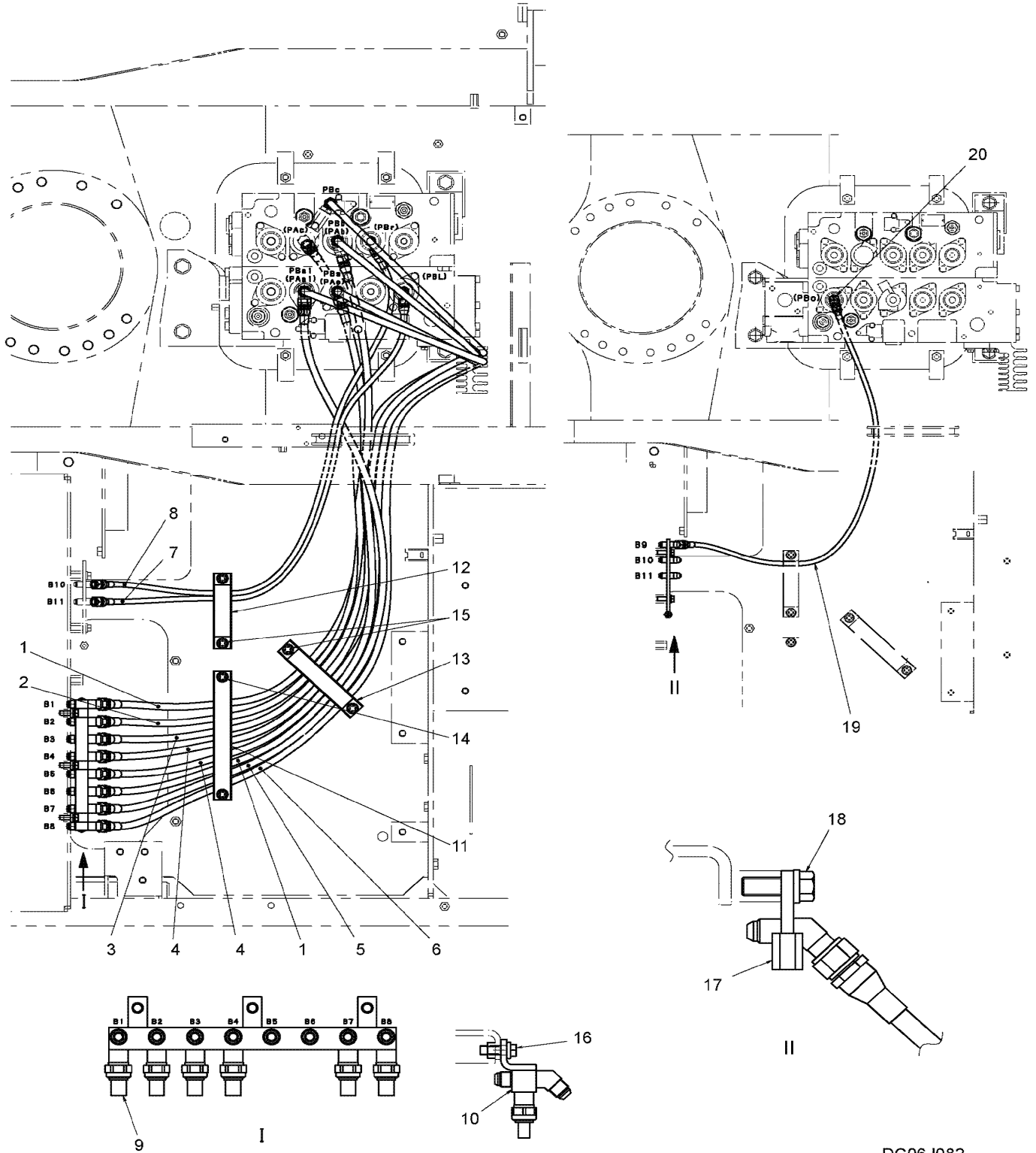

DC06J082

5.014

00

p2

4/2021

CONTROL LINES, REMOTE (NIBBLER & BREAKER - FOOT) (YN68H00138F1), FIGURE 2 OF 2

| REF FN | PART NUMBER | YR/SN | QTY DESCRIPTION |
|--------|--------------|-------|--|
| A9 | LC52S00019P1 | | 1 SENSOR 0 - 3 MPa, 3 Terminal, PF 1/4" Pressure (Low Pressure) -- Replaced YX52S00013P1 (Incls. O-Ring ZD12P01100) |
| A9-2 | ZD12P01100 | | 1 O-RING 10.8mm ID x 15.6mm OD x 2.4mm Thk (Part of LC52S00019P1), ID 10.80 ± 0.18 x OD 15mm |
| A10 | HM83C10030G1 | | 2 BOLT M10 x 30mm M10x30mm |
| A11 | ZH22X04006 | | 1 HYD CONNECTOR Male, 30 Deg FI, PF 3/8" x PF 1/4" x 36mm L, O-Ring (Incls. O-Ring ZD12P01400) |
| | ZD12P01400 | | 1 O-RING 13.8mm ID x 18.6mm OD x 2.4mm Thk (Part of ZH22X04006), ID 13.80 ± 0.19 x OD 18mm, Not Shown |
| | YN64H00225F1 | | CONTROL BLOCK Block Control Lines |
| B1 | YN64H01292P1 | | 1 BLOCK 192mm Long (7-35/64 in) |
| B2 | 2420R349D110 | | 2 HOSE PF 1/4", 6.4mm ID x 10.4mm OD x 1100mm L |
| B3 | 2420R349D120 | | 1 HOSE PF 1/4", 6.4mm ID x 10.4mm OD x 1200mm L |
| B4 | ZH42X04006 | | 1 45 ELBOW Male, 30 Degree FI, PF 1/4" x PF 3/8", O-Ring 45° -- 1/4"PFx3/8"PFx53.5mm Long (Incls. O-Ring ZD12P01400) |
| | ZD12P01400 | | 1 O-RING 13.8mm ID x 18.6mm OD x 2.4mm Thk (Part of ZH42X04006), ID 13.80 ± 0.19 x OD 18mm, Not Shown |
| B5 | HM83C10030G1 | | 2 BOLT M10 x 30mm M10x30mm |
| B6 | YN64H01288P1 | | 1 CLAMP Plate -- 164x36x14.5mm |
| B7 | ZM73C10020 | | 2 BOLT M10 x 1.50 x 20mm - Course Thread M10x1.50x20mm (Incls. Washer) |
| | LC64H00090F1 | | CONTROL Block Control Lines (PT-1Pedal) |
| C1 | YN64H01337P1 | | 1 BLOCK Manifold |
| C2 | ZM73C08020 | | 3 BOLT M8 x 1.25 x 20mm - Course Thread M08x1.25x20mm (Incls. Washer) |

E215B-CRAWLER EXCAVATOR - TIER 3 (NA) - ASN N7DA21001

5.016

00

p3

4/2021

INSTRUMENT PANEL ASSEMBLY (NIBBLER & BREAKER) (YN17M00064F1), FIGURE 1 OF 3

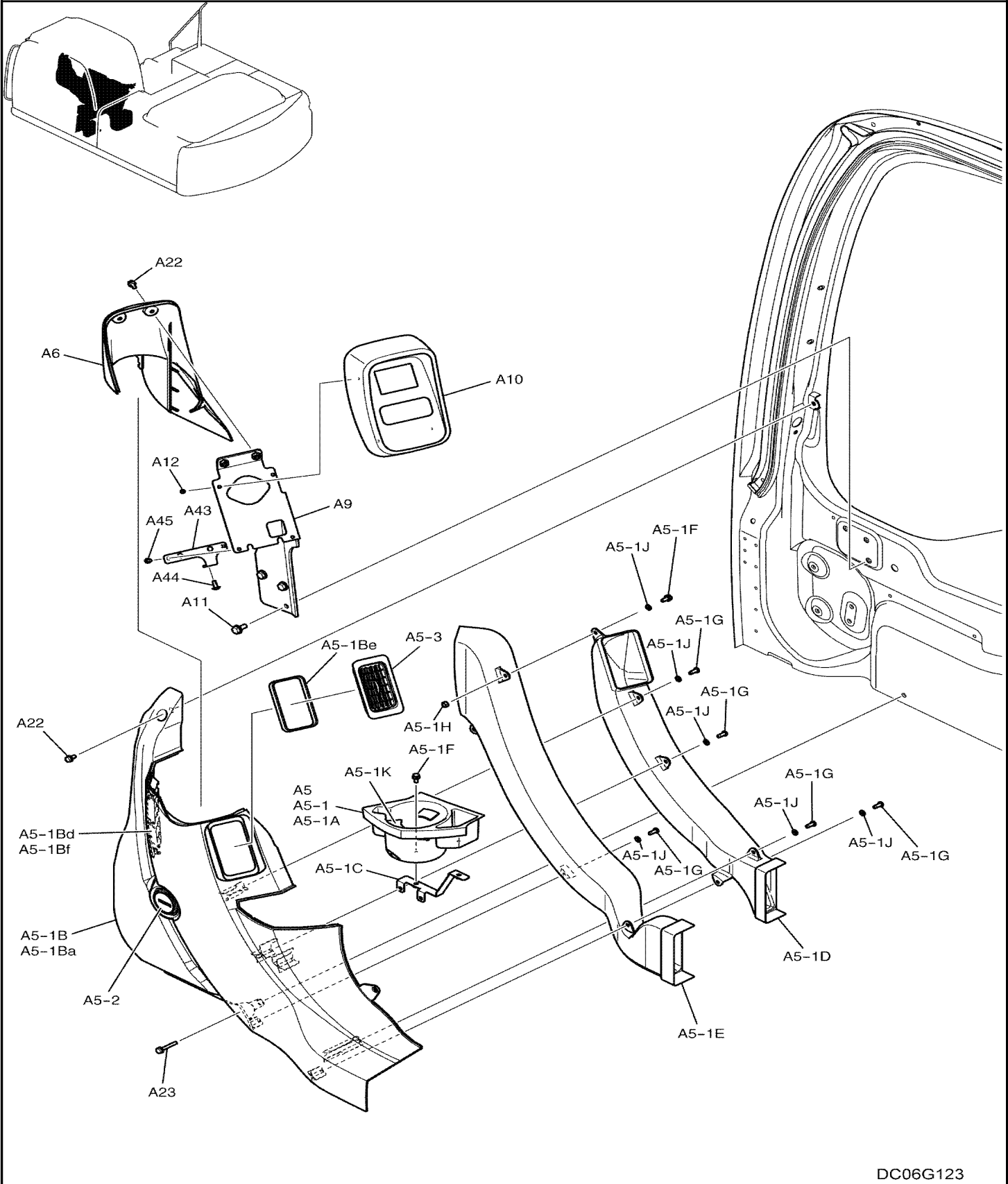

INSTRUMENT PANEL ASSEMBLY (NIBBLER & BREAKER) (YN17M00064F1), FIGURE 3 OF 3

| REF FN | PART NUMBER | YR/SN | QTY DESCRIPTION |
|--------|--------------|-------|--|
| A19-2B | YN20M01633P1 | | 1 FOAM INSULATION 6mm W x 8mm H x 550mm L 6x8x550mm Long (21-21/32 in) |
| A19-3 | YN20M01634F1 | | 1 DUCT Assembly, Incls. Refs. A19-3A - A19-3C |
| A19- | YN20M01635P1 | | 1 DUCT |
| A19-3B | YN20M01636P1 | | 1 FOAM INSULATION 6mm W x 8mm H x 485mm L 6x8x485mm Long (19-3/32 in) |
| A19-3C | YN20M01637P1 | | 1 FOAM INSULATION 6mm W x 8mm H x 410mm L 6x8x410mm Long (16-9/64 in) |
| A20 | YN20M01638F1 | | 1 DUCT Assembly, Incls. Refs. A20-1 & A20-2 |
| A20-1 | YN20M01639F1 | | 1 DUCT Assembly, Incls. Refs. A20-1A & A20-1B |
| A20- | YN20M01640P1 | | 1 DUCT |
| A20- | YN20M01641P1 | | 1 DUCT |
| A20-2 | YN20M01642P1 | | 1 FOAM INSULATION 104.5mm W x 10mm H x 300mm L 104.5x10x300mm Long (11-13/16 in) |
| A22 | ZM66C06016 | | 19 BOLT M6 x 1.0 x 16mm M06x1.0x16mm (Incls. Washer & Lockwasher) |
| A24 | ZM66C08016 | | 2 BOLT M8 x 1.25 x 16mm M08x1.25x16mm (Incls. Washer & Lockwasher) |
| A27 | YN17M01262P1 | | 12 SCREW Phillips Drive, Pan HD, M5 x 10mm M05x10mm Self-Taper |
| A28 | ZW16P05000 | | 12 WASHER 5mm ID x 10mm OD x 1.0mm Thk ID 05 x OD 10 x Th 1.0mm |
| A36 | YN17M01278P2 | | 1 BRACKET |
| A37 | YN17M01279P1 | | 1 BRACKET |
| A38 | ZS32T50012 | | 2 SELF-TAP SCREW M5 x 12mm M05x12mm Self-Taper |
| A41 | YN01T01049F1 | | 1 HAMMER |

E215B-CRAWLER EXCAVATOR - TIER 3 (NA) - ASN N7DA21001

5.039

00

p1

4/2021

SUN VISOR ASSEMBLY (YN55C00013F1)

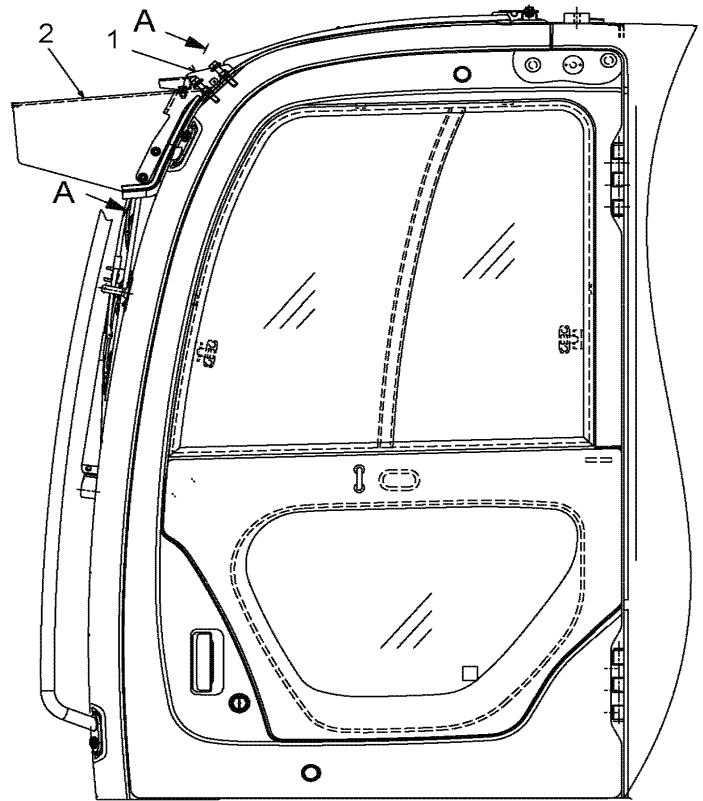
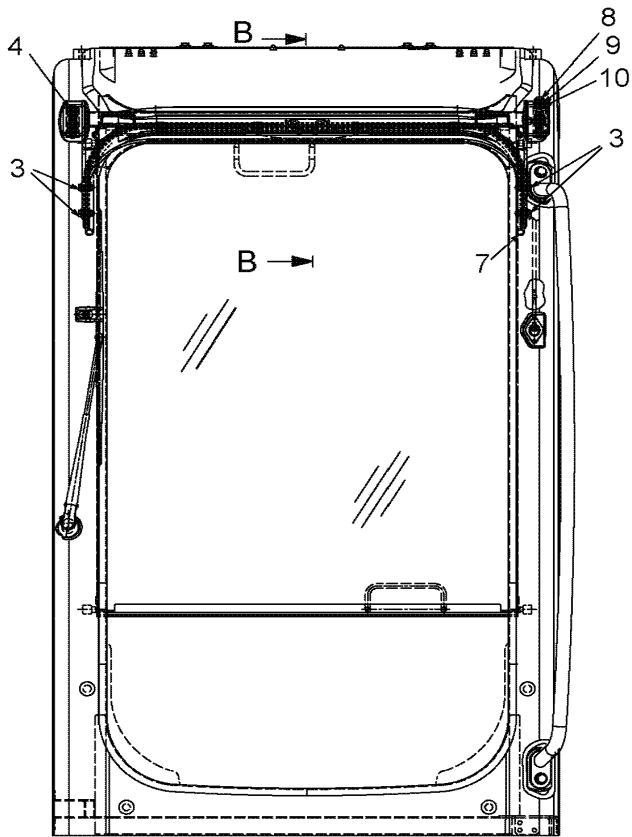
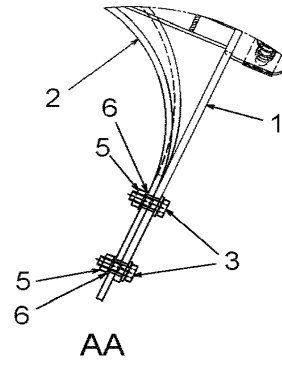
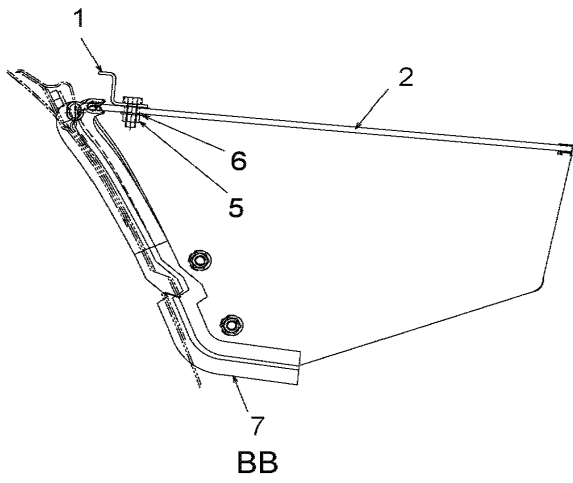

DCJ06J016

5.041

00

p1

4/2021

CONTROL LINES, MAIN (EXTREME REACH) (YN06H00104F1), FIGURE 2 OF 2

| REF FN | PART NUMBER | YR/SN | QTY DESCRIPTION |
|--------|--------------|-------|---|
| | { } | | Extreme Reach Main Control Lines, YN06H00104F1, Figure 2 of 2 |
| | { } | | Extreme Reach Main Control Lines, YN06H00102F1, Incls. Refs. 1-23 |
| 1 | 2420R537D030 | | 1 HOSE PF 3/8", 9.5mm ID x 14mm OD x 300mm L |
| 2 | 2420R349D028 | | 1 HOSE PF 1/4", 6.4mm ID x 10.4mm OD x 280mm L 280mm Long (11-1/32 in) |
| 3 | 2420R349D055 | | 1 HOSE PF 1/4", 6.4mm ID x 10.4mm OD x 550mm L |
| 4 | 2420R537D088 | | 1 HOSE PF 3/8", 9.5mm ID x 14mm OD x 880mm L Hose -- 880mm Long (34-41/64 in) |
| 5 | 2420R349D125 | | 1 HOSE PF 1/4", 6.4mm ID x 10.4mm OD x 1250mm L |
| 6 | 2420R349D120 | | 1 HOSE PF 1/4", 6.4mm ID x 10.4mm OD x 1200mm L |
| 7 | YN21V00005F1 | | 1 CHECK VALVE PF 3/8 x PF 3/8 Assembly, Check -- (Incls. O-Ring ZD12P01400) |
| | ZD12P01400 | | 1 O-RING 13.8mm ID x 18.6mm OD x 2.4mm Thk (Part of YN21V00005F1), ID 13.80 ± 0.19 x OD 18mm, Not Shown |
| 8 | LC52S00019P1 | | 1 SENSOR 0 - 3 MPa, 3 Terminal, PF 1/4" Pressure (Low Pressure) -- Replaced YX52S00013P1 (Incls. O-Ring ZD12P01100) |
| | ZD12P01100 | | 1 O-RING 10.8mm ID x 15.6mm OD x 2.4mm Thk (Part of LC52S00019P1), ID 10.80 ± 0.18 x OD 15mm, Not Shown |
| 9 | ZH22X04000 | | 3 HYD CONNECTOR Male, 30 Deg Fl, 1/4" PF x 1/4" PF x 36mm L 1/4"PFx36mm Long (Incls. O-Ring 237-6004) |

E215B-CRAWLER EXCAVATOR - TIER 3 (NA) - ASN N7DA21001

5.043

00

p2

4/2021

CONTROLLER INSTALLATION (LONG REACH) (YN22E00267F1)

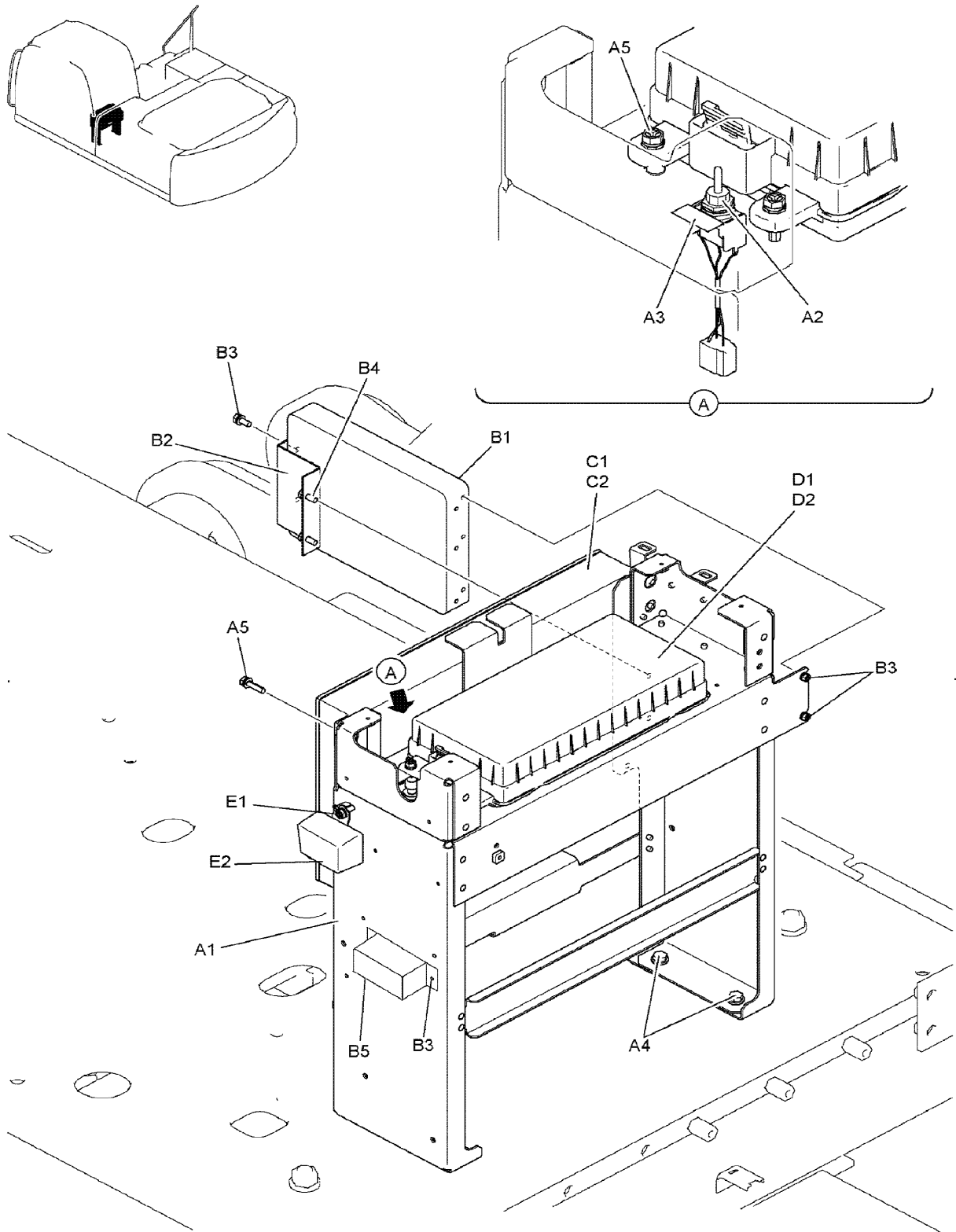

DC06J086

| | | | |
|--------------|----|----|--------|
| 6.004 | 00 | p1 | 4/2021 |
|--------------|----|----|--------|

CAP ASSEMBLY (YN02B01737F1)

| REF FN | PART NUMBER | YR/SN | QTY DESCRIPTION |
|--------|--------------|-------|--|
| | ⌋ | | Cap Assembly, YN02B01737F1 |
| 1 | PV02B01073D3 | | AR CAP Nylon, 10.7mm OD x 5.5mm L 10.7mm Plastic |
| 2 | PV02B01073D4 | | 2 CAP Nylon, 9mm OD x 5.5mm L 09.3mm Plastic |

E215B-CRAWLER EXCAVATOR - TIER 3 (NA) - ASN N7DA21001

6.009

00

p1

4/2021

VANDALISM GUARD (YN25C00008F1), FIGURE 1 OF 2

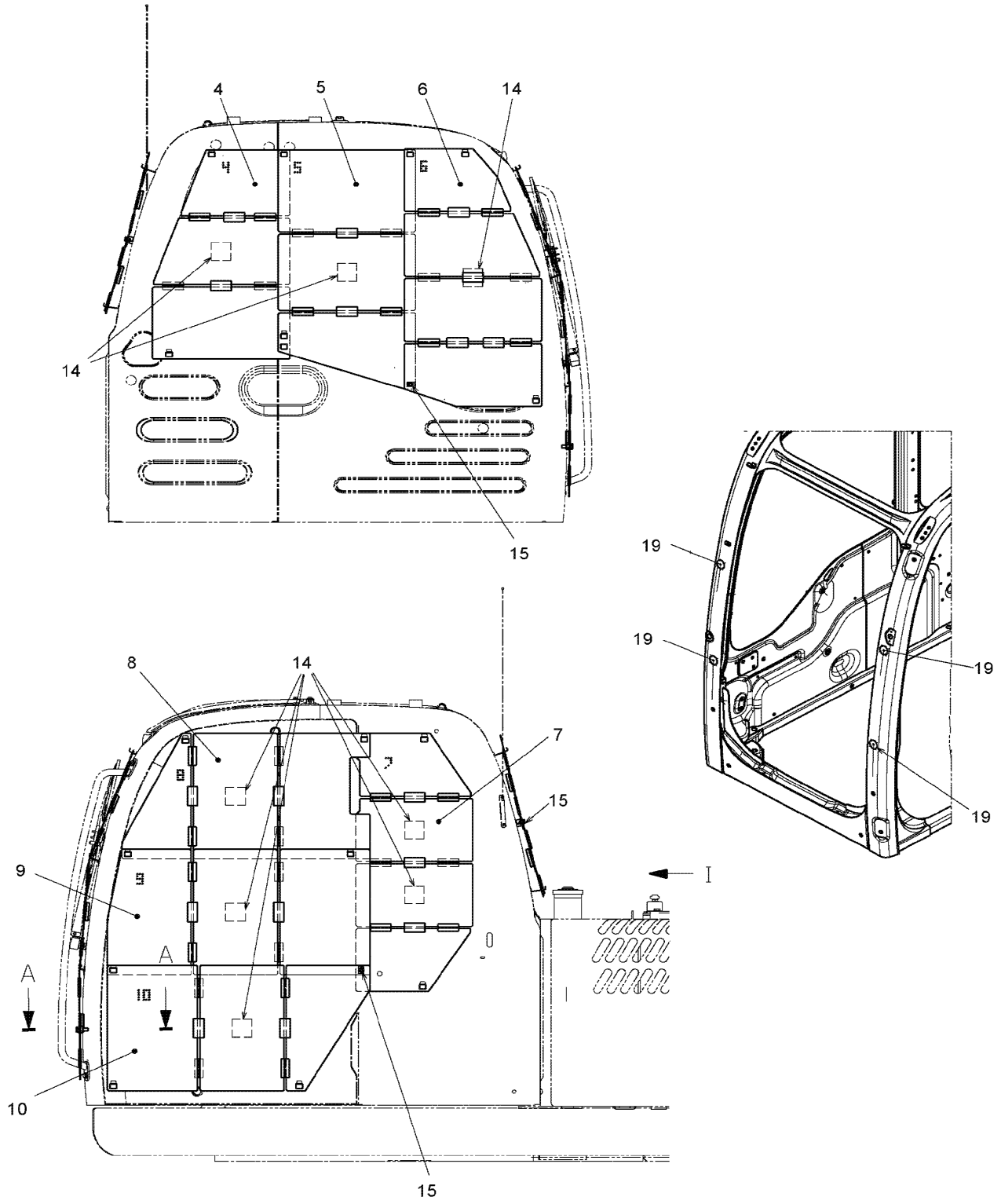

DC06J022

6.012

00

p1

4/2021

ROLLER ASSEMBLY UPPER (HIGH & WIDE) (YN64DU0004F1)

| REF FN | PART NUMBER | YR/SN | QTY DESCRIPTION |
|--------|--------------|-------|---|
| | ∅ | | Upper Roller Assembly (High & Wide), YN64DU0004F1, Incls. Refs. 1 & 2 |
| | ∅ | | Used from date 07/21/2006 - 04/13/2007 |
| 1 | YF64D00001F1 | | 4 ROLLER Assembly, Incls. Refs. 1-1 - 1-8 |
| 1-1 | YN64D01021P1 | | 1 ROLLER OD Ø185 x 220mm Long |
| 1-2 | YN64D01041P1 | | 2 COLLAR |
| 1-3 | YN64D01042P1 | | 1 SHAFT OD 65 x 338mm Long |
| 1-4 | 2405P489 | | 2 BUSHING 66mm ID x 87mm OD x 64.5mm L ID 65 x OD 69 x 60mm Long |
| 1-5 | YN64D01043P1 | | 2 PIN 16mm OD x 76mm L OD 16 x 76mm Long |
| 1-6 | 2445R451F1 | | 2 SEAL 90mm ID x 114.45mm OD x 33mm Thk |
| 1-7 | ZD11G06000 | | 2 O-RING 59.4mm ID x 65.6mm OD x 3.1mm Thk ID 59.40 ± 0.61 x OD 65mm |
| 1-8 | ZE82T04000 | | 2 PLUG 1/4" PT 1/4" PT |
| | ∅ | | Used after date 04/13/2007 - Up |
| 1 | LQ64D00029F1 | | 4 ROLLER, TRACK Assembly, Incls. Refs. 1-1 - 1-8 |
| 1-1 | LQ64D01027P1 | | 1 ROLLER 185mm OD x 220mm L Roller -- OD Ø185 x 220mm Long |
| 1-2 | YN64D01020P1 | | 2 COLLAR Replaces YN64D01041P1 |
| 1-3 | 2410N862 | | 1 SHAFT 65mm OD x 354mm L OD 65 x 354mm Long -- Replaces YN64D01042P1, OD 65 x 338mm Long |
| 1-4 | 2405P489 | | 2 BUSHING 66mm ID x 87mm OD x 64.5mm L ID 65 x OD 69 x 60mm Long |
| 1-5 | 2419T7353 | | 2 PIN 16mm OD x 83mm L OD 16 x 83mm Long -- Replaces YN64D01043P1, OD 16 x 76mm Long |

E215B-CRAWLER EXCAVATOR - TIER 3 (NA) - ASN N7DA21001

6.015

00

p1

4/2021

FRAME ASSEMBLY, LOWER (HIGH & WIDE) (YN02FU0019F1)

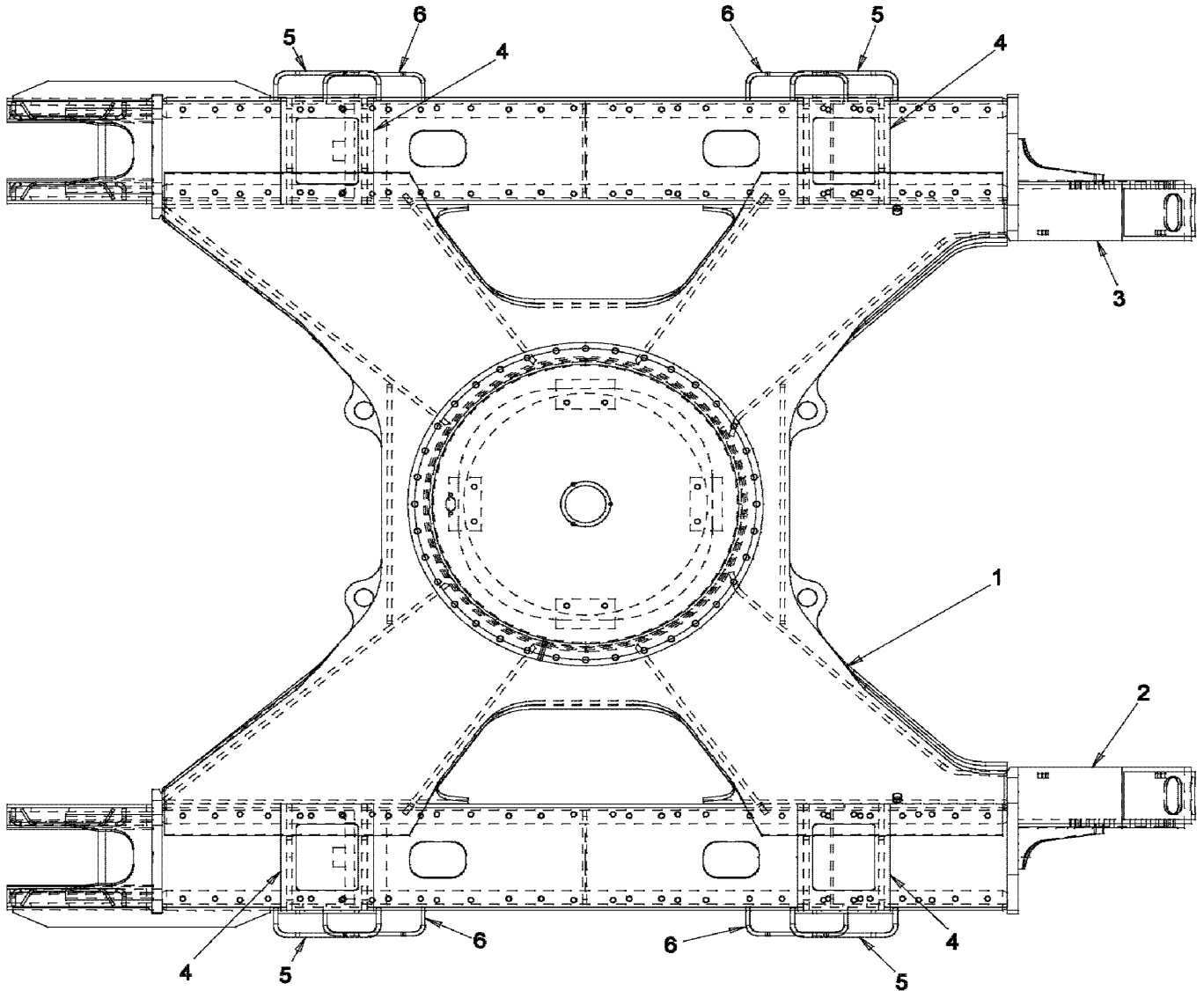

DC06J043

7.008

00

p1

4/2021

NAME PLATE INSTALLATION, CAUTION LABEL (YN22T00340F4)

| REF FN | PART NUMBER | YR/SN | QTY DESCRIPTION |
|---------------|--------------------|--------------|---|
| 32 | Y20T01872P1 | | 1 LABEL Decal, Caution, Hydraulic oil can be hot after machine operation. Allow oil ... |

E215B-CRAWLER EXCAVATOR - TIER 3 (NA) - ASN N7DA21001

NAME PLATE INSTALLATION, (LIFT CHARTS) (YN22TU0022F1 - F8), FIGURE 2 OF 3

1

E215B LC-VIII RATED LIFT CAPACITY

Based on machine equipped with
Dum 9" x 27" (234mm) tire
Bucket SAE heaped 1.05cu. yd(0.80m³) bucket
Shoe 22.6" (580mm) triple grouser shoe

Table with columns for Lift Point Radius (9.5', 10', 11.5', 12', 12.5') and AT MAX. REACH RADIUS. Rows include various load capacities in lbs and kg.

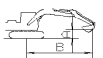

- 1. Do not attempt to lift or hold any load that is greater than the lift capacity...
2. Lift capacities are based on machine standing on level, firm and uniform ground...
3. Bucket lift hook is defined as lift point.

YN20TU1239P2

2

E215B LC-VIII RATED LIFT CAPACITY (HEAVY LIFT)

Based on machine equipped with
Dum 9" x 27" (234mm) tire
Bucket SAE heaped 1.05cu. yd(0.80m³) bucket
Shoe 22.6" (580mm) triple grouser shoe

Table with columns for Lift Point Radius (9.5', 10', 11.5', 12', 12.5') and AT MAX. REACH RADIUS. Rows include various load capacities in lbs and kg.

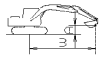

- 1. Do not attempt to lift or hold any load that is greater than the lift capacity...
2. Lift capacities are based on machine standing on level, firm and uniform ground...
3. Bucket lift hook is defined as lift point.

YN20TU1239P2

3

E215B LC-VIII RATED LIFT CAPACITY

Based on machine equipped with
Dum 9" x 27" (234mm) tire
Bucket SAE heaped 1.05cu. yd(0.80m³) bucket
Shoe 27.6" (700mm) triple grouser shoe

Table with columns for Lift Point Radius (9.5', 10', 11.5', 12', 12.5') and AT MAX. REACH RADIUS. Rows include various load capacities in lbs and kg.

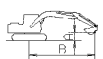

- 1. Do not attempt to lift or hold any load that is greater than the lift capacity...
2. Lift capacities are based on machine standing on level, firm and uniform ground...
3. Bucket lift hook is defined as lift point.

YN20TU1239P2

4

E215B LC-VIII RATED LIFT CAPACITY (HEAVY LIFT)

Based on machine equipped with
Dum 9" x 27" (234mm) tire
Bucket SAE heaped 1.05cu. yd(0.80m³) bucket
Shoe 27.6" (700mm) triple grouser shoe

Table with columns for Lift Point Radius (9.5', 10', 11.5', 12', 12.5') and AT MAX. REACH RADIUS. Rows include various load capacities in lbs and kg.

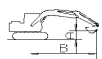

- 1. Do not attempt to lift or hold any load that is greater than the lift capacity...
2. Lift capacities are based on machine standing on level, firm and uniform ground...
3. Bucket lift hook is defined as lift point.

YN20TU1239P2

5

E215B LC-VIII RATED LIFT CAPACITY

Based on machine equipped with
Dum 9" x 27" (234mm) tire
Bucket SAE heaped 1.05cu. yd(0.80m³) bucket
Shoe 31.5" (800mm) triple grouser shoe

Table with columns for Lift Point Radius (9.5', 10', 11.5', 12', 12.5') and AT MAX. REACH RADIUS. Rows include various load capacities in lbs and kg.

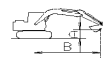

- 1. Do not attempt to lift or hold any load that is greater than the lift capacity...
2. Lift capacities are based on machine standing on level, firm and uniform ground...
3. Bucket lift hook is defined as lift point.

YN20TU1239P2

6

E215B LC-VIII RATED LIFT CAPACITY (HEAVY LIFT)

Based on machine equipped with
Dum 9" x 27" (234mm) tire
Bucket SAE heaped 1.05cu. yd(0.80m³) bucket
Shoe 31.5" (800mm) triple grouser shoe

Table with columns for Lift Point Radius (9.5', 10', 11.5', 12', 12.5') and AT MAX. REACH RADIUS. Rows include various load capacities in lbs and kg.

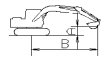

- 1. Do not attempt to lift or hold any load that is greater than the lift capacity...
2. Lift capacities are based on machine standing on level, firm and uniform ground...
3. Bucket lift hook is defined as lift point.

YN20TU1239P2

7

E215B LC-VIII RATED LIFT CAPACITY

Based on machine equipped with
Dum 9" x 27" (234mm) tire
Bucket SAE heaped 1.05cu. yd(0.80m³) bucket
Shoe 35.4" (900mm) triple grouser shoe

Table with columns for Lift Point Radius (9.5', 10', 11.5', 12', 12.5') and AT MAX. REACH RADIUS. Rows include various load capacities in lbs and kg.

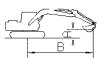

- 1. Do not attempt to lift or hold any load that is greater than the lift capacity...
2. Lift capacities are based on machine standing on level, firm and uniform ground...
3. Bucket lift hook is defined as lift point.

YN20TU1239P2

8

E215B LC-VIII RATED LIFT CAPACITY (HEAVY LIFT)

Based on machine equipped with
Dum 9" x 27" (234mm) tire
Bucket SAE heaped 1.05cu. yd(0.80m³) bucket
Shoe 35.4" (900mm) triple grouser shoe

Table with columns for Lift Point Radius (9.5', 10', 11.5', 12', 12.5') and AT MAX. REACH RADIUS. Rows include various load capacities in lbs and kg.

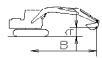

- 1. Do not attempt to lift or hold any load that is greater than the lift capacity...
2. Lift capacities are based on machine standing on level, firm and uniform ground...
3. Bucket lift hook is defined as lift point.

YN20TU1239P2

NAME PLATE INSTALLATION, (PATTERN CHANGE) (YN22T00341F2), FIGURE 2 OF 2

| REF FN | PART NUMBER | YR/SN | QTY DESCRIPTION |
|--------|--------------|-------|--|
| | ∅ | | Name Plate Installation (Pattern Change), YN22T00341F2, Figure 2 of 2 |
| 1 | YN20T01863P1 | | 1 LABEL Decal, Multi Warnings and Notice |
| 2 | PH20T01018P1 | | 2 WARNING DECAL Decal, Hammer Hand and Man running |
| 3 | YN20T01864P1 | | 1 LABEL Decal, Lever Control Unlock and Control Lockout |
| 5 | YN20T01407P1 | | 1 LABEL Decal, Kobelco Construction Machine Co. LTD. |
| 6 | YN20T01862P1 | | 1 LABEL Decal, Intelligent Total Control System |
| 7 | ZL11M06008 | | 1 LABEL Decal, Window Lock and Unlock |
| 8 | YN20T01339P1 | | 2 CAUTION DECAL Decal, Caution -- Be careful not to pinch your hand(s) when operating the lever. |
| 9 | YN20T01799P1 | | 1 LABEL Decal, Unlock and Locked |
| 10 | YN20T01800P1 | | 1 LABEL Decal, Lock and Unlocked |
| 11 | YN20T01639P1 | | 1 LABEL Decal, Caution, Swing parking brake release switch is installed on the rear side this cover. |
| 12 | YN20T01475P1 | | 1 LABEL Holder |
| 13 | YN20T01476P1 | | 1 LABEL Decal, Control location and positions |
| 14 | YN20T01039P1 | | 1 WARNING DECAL Warning, This machine equipped with a rotary multi-control valve which allows changing of... |

E215B-CRAWLER EXCAVATOR - TIER 3 (NA) - ASN N7DA21001

7.026

03

p1

4/2021

NAME PLATE INSTALLATION, (EXTERIOR) (YN22TU0023F1), FIGURE 3 OF 3

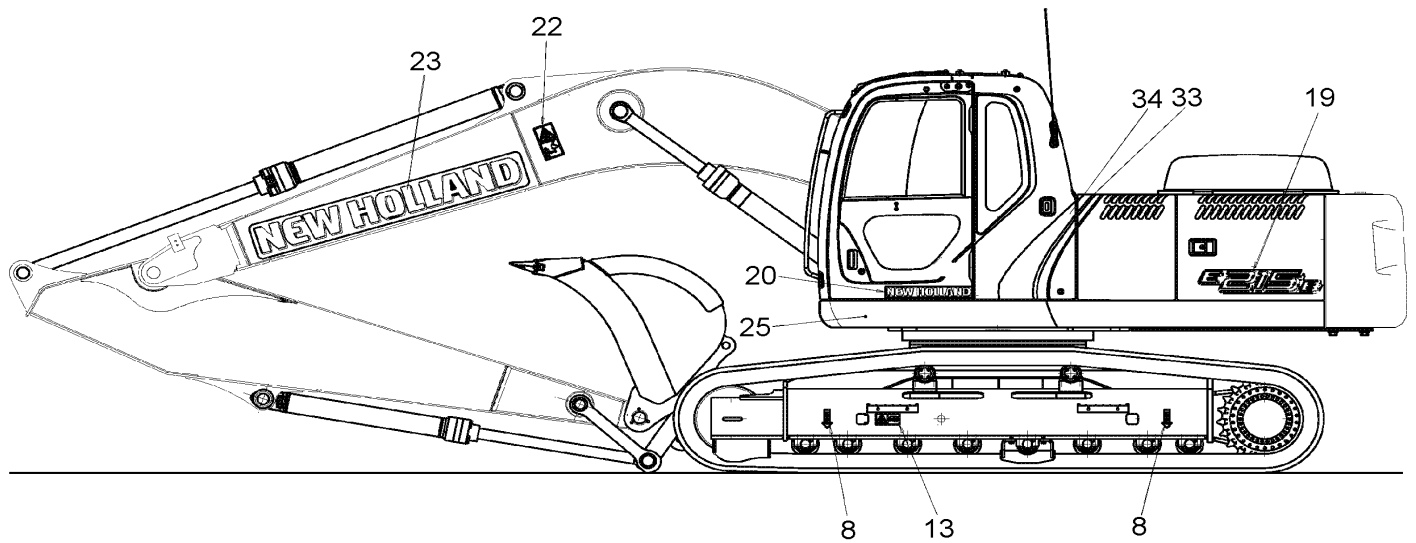
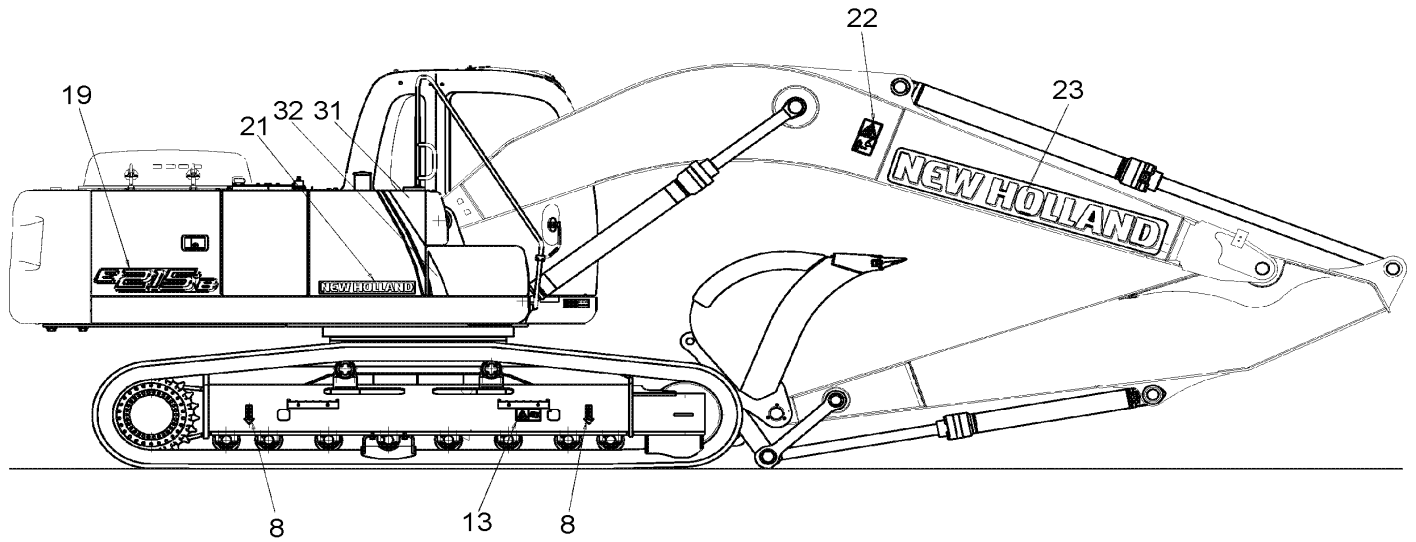

DC06L037

8.004

00

p1

4/2021

VALVE ASSEMBLY, CONTROL (LC30V00101F1) (HC001), FIGURE 4 OF 5

| REF FN | PART NUMBER | YR/SN | QTY DESCRIPTION |
|--------|----------------|-------|---|
| | YN30V00101F1 | | AR VALVE, CONTROL Assembly, Figure 4 of 5 |
| 160 | NA | | 5 NOT SERVICED PLug |
| 161 | ZD12P03800 | | 7 O-RING 37.7mm ID x 44.7mm OD x 3.5mm Thk ID 37.70 ± 0.37 x OD 44.7mm |
| 162 | ZD12G03000 | | 15 O-RING 29.40mm ID x 35.60mm OD x 3.10mm ID 29.4 ± 0.29 x OD 35mm |
| 163 | ZD12P01500 | | 11 O-RING 14.8mm ID x 19.6mm OD x 2.4mm Thk ID 14.80 ± 0.20 x OD 19mm |
| 164 | ZD12P02400 | | 19 O-RING 23.7mm ID x 30.7mm OD x 3.5mm Thk ID 23.70 ± 0.24 x OD 30mm |
| 201 | YN30V00101S201 | | 5 GUARD Cover |
| 203 | YN30V00101S203 | | 1 GUARD Cover |
| 204 | YN30V00101S204 | | 1 GUARD Cover |
| 205 | YN30V00001S205 | | 7 COVER |
| 206 | YN30V00101S206 | | 1 GUARD Cover |
| 209 | YN30V00101S209 | | 1 GUARD Cover |
| 211 | YN30V00119F1 | | 2 VALVE Assembly, Lock |
| 216 | YN30V00101S216 | | 1 PISTON |
| 261 | ZD12G05000 | | 12 O-RING 49.40mm ID x 55.60mm OD x 3.10mm ID 49.40 ± 0.45 x OD 55mm |
| 264 | ZD12G04000 | | 10 O-RING 39.40mm ID x 45.60mm OD x 3.10mm ID 39.40 ± 0.37 x OD 45mm |
| 266 | ZD12P00700 | | 4 O-RING 6.8mm ID x 10.6mm OD x 1.9mm Thk O-Ring -- ID 06.80 ± 0.16 x OD 10mm |
| 301 | YN30V00101S301 | | 1 SPOOL |
| 302 | YN30V00101S302 | | 1 SPOOL |
| 303 | YN30V00101S303 | | 1 SPOOL |
| 304 | YN30V00101S304 | | 1 SPOOL |
| 321 | YN30V00079S321 | | 5 SPRING |
| 322 | YN30V00079S322 | | 4 SPRING |

E215B-CRAWLER EXCAVATOR - TIER 3 (NA) - ASN N7DA21001

8.008

00

p1

4/2021

VALVE ASSEMBLY, CONTROL (YN30V00104F1) (HC100)

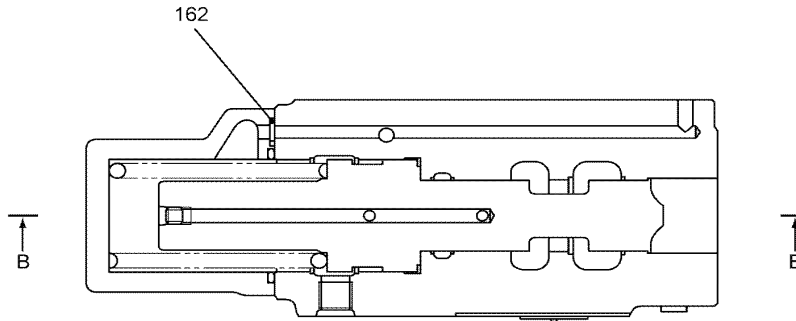
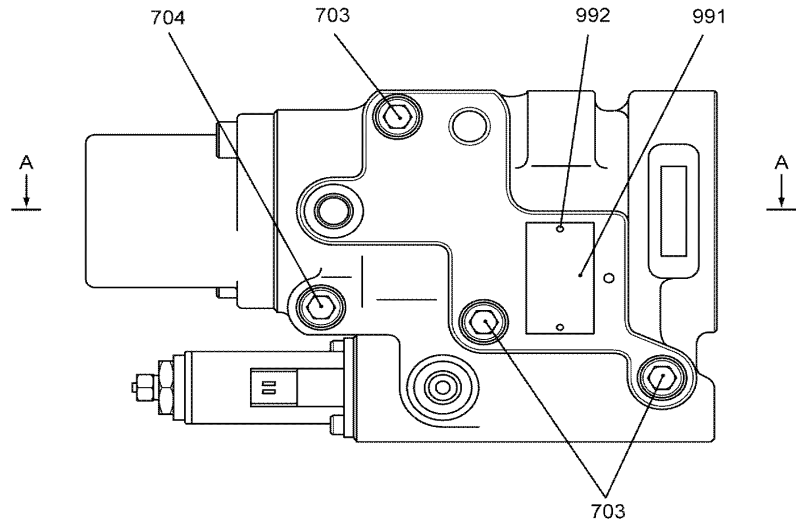

SECTION A-A

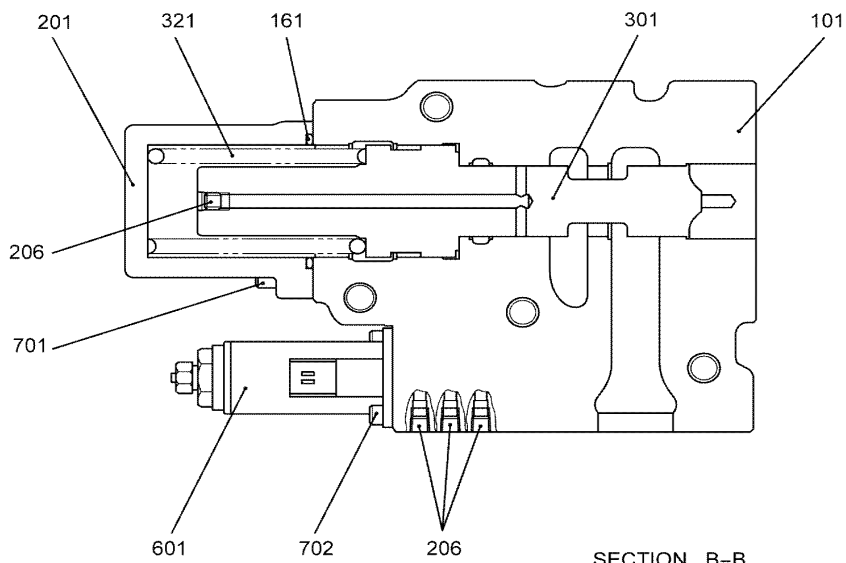

SECTION B-B

VALVE ASSEMBLY, RELIEF (YN22V00041F1)

| REF FN | PART NUMBER | YR/SN | QTY DESCRIPTION |
|--------|--------------|-------|---|
| | YN22V00041F1 | | AR HYDRAULIC VALVE Assembly, Relief |
| 101 | NSS | | 1 NOT SOLD SEPARAT Body |
| 102 | NSS | | 1 NOT SOLD SEPARAT Plug |
| 124 | NSS | | 1 NOT SOLD SEPARAT Stop |
| 125 | NSS | | 1 NOT SOLD SEPARAT Filter |
| 161 | ZD12P02000 | | 1 O-RING 19.8mm ID x 24.6mm OD x 2.4mm Thk ID 19.80 ± 0.22 x OD 24mm |
| 162 | NSS | | 1 NOT SOLD SEPARAT O-Ring |
| 301 | NSS | | 1 NOT SOLD SEPARAT Piston |
| 511 | NSS | | 1 NOT SOLD SEPARAT Poppet |
| 521 | NSS | | 1 NOT SOLD SEPARAT Spring |
| 522 | NSS | | 1 NOT SOLD SEPARAT Spring |
| 541 | NSS | | 1 NOT SOLD SEPARAT Seat |
| 561 | NSS | | 1 NOT SOLD SEPARAT O-Ring |
| 562 | NSS | | 1 NOT SOLD SEPARAT Ring, Back-Up |
| 563 | NSS | | 1 NOT SOLD SEPARAT O-Ring |
| 564 | NSS | | 1 NOT SOLD SEPARAT Ring, Back-Up |
| 611 | NSS | | 1 NOT SOLD SEPARAT Poppet |
| 621 | NSS | | 1 NOT SOLD SEPARAT Spring |
| 651 | NSS | | 1 NOT SOLD SEPARAT Screw |
| 671 | NSS | | 1 NOT SOLD SEPARAT Nut, Lock -- M8 |
| 701 | NSS | | 1 NOT SOLD SEPARAT Seal |

E215B-CRAWLER EXCAVATOR - TIER 3 (NA) - ASN N7DA21001

8.011.01

00

p2

4/2021

REDUCTION ASSEMBLY (SWING) (YN32W00022F1)

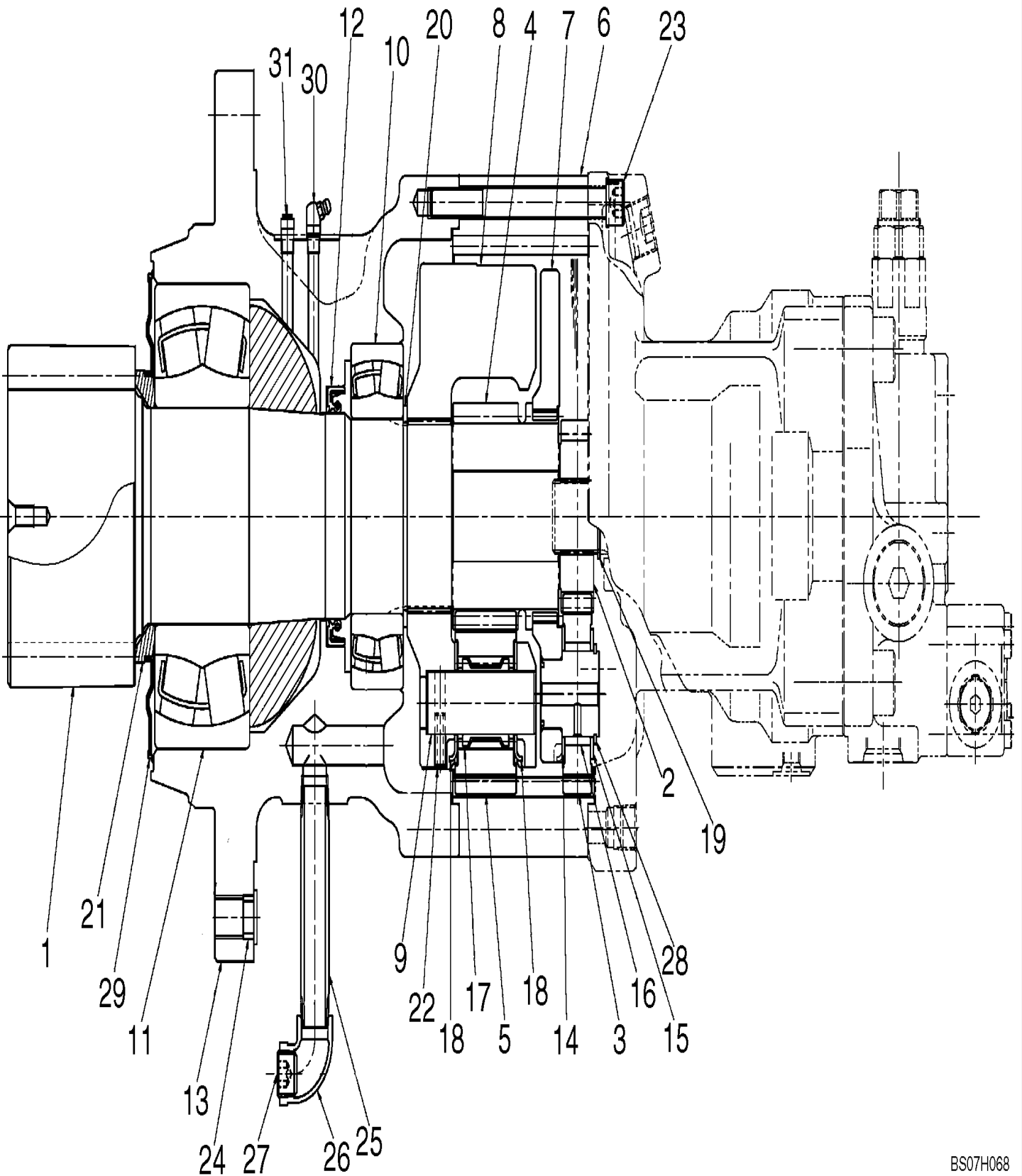

8.015

01

p2

4/2021

PUMP ASSEMBLY (YN10V00043F1) (HC405), FIGURE 1 OF 2

| REF FN | PART NUMBER | YR/SN | QTY DESCRIPTION |
|--------|----------------|-------|--|
| 468 | 2441U436S469 | | 4 PLUG |
| 490 | 2441U722S490 | | 32 PLUG 1/16" NPTF |
| 531 | NA | | 2 NOT SERVICED Pin |
| 532 | 2437U213S532 | | 2 PISTON |
| 534 | 2437U213S534 | | 2 STOP |
| 535 | 2437U213S535 | | 2 STOP |
| 546 | YN10V00043S546 | | 2 SPACER |
| 548 | NA | | 2 NOT SERVICED Pin, Feedback |
| 702 | YN10V00003S702 | | 2 O-RING |
| 710 | YX10V00003S012 | | 2 O-RING Used Between Hyd Pump & Cover Plate or Hyd Pump and Gear Case |
| 717 | YN10V00020S012 | | 4 O-RING 3.1mm Thk x 144.4mm ID, 70 Duro |
| 724 | YX10V00003S015 | | 16 O-RING 1.9mm Thk x 8.8mm ID, 75 Duro |
| 725 | YT10V00003S710 | | 9 O-RING |
| 727 | YN10V01001S727 | | 3 O-RING |
| 728 | YN10V00020S015 | | 4 O-RING |
| 732 | YT10V00003S708 | | 2 O-RING |
| 774 | YN10V00032S775 | | 1 OIL SEAL |
| 789 | ZD85P01800 | | 2 BACK-UP RING 18mm ID x 22mm OD x 1.25mm Thk |
| 792 | ZD85G03500 | | 2 BACK-UP RING 35mm ID x 40mm OD x 1.25mm Thk |
| 806 | ZN18C16010 | | 2 NUT M16 x 2.0 |
| 808 | ZN18C20012 | | 2 NUT M20 x 2.5 |
| 824 | ZR16X04000 | | 2 SNAP RING 37mm ID x 40mm OD x 1.8mm Thk Reatining |
| 885 | 2441U723S885 | | 2 PIN |
| 886 | ZP26D06014 | | 4 PIN 6mm OD x 14mm L Roll |
| 901 | ZS91C01000 | | 2 BOLT M10 x 1.50 x 18mm Eye |
| 953 | 2437U188S953 | | 2 SET SCREW M10 x 20mm |
| 954 | 2437U213S954 | | 2 SET SCREW |
| 981 | YB15V00003S390 | | 1 PLATE Name Plate |

E215B-CRAWLER EXCAVATOR - TIER 3 (NA) - ASN N7DA21001

8.017

01

p2

4/2021

REGULATOR ASSEMBLY (YN10V01009F1) (HC410), FIGURE 1 OF 2

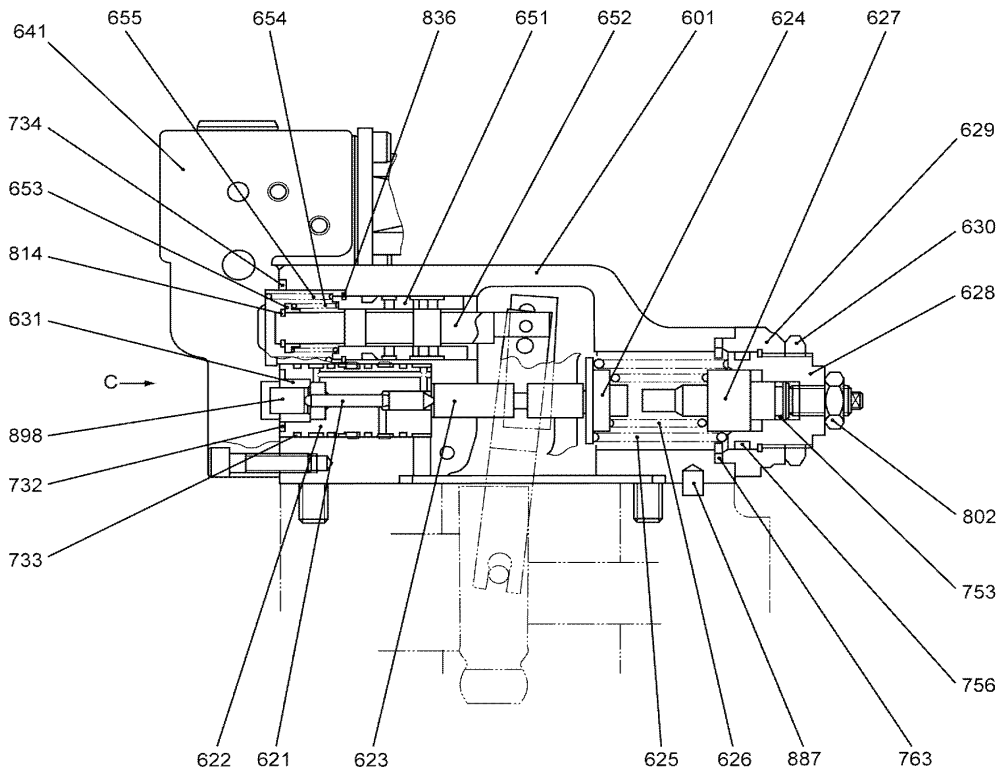
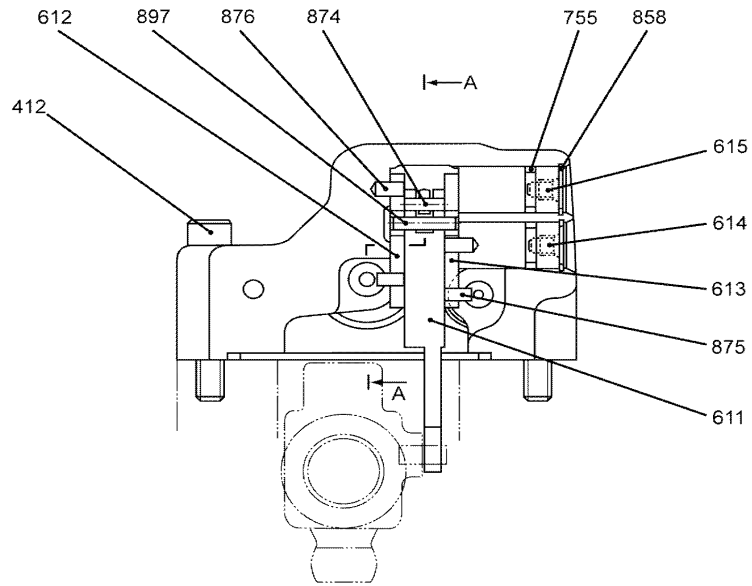

SECTION A-A

HC410-01-1

8.018

00

p1

4/2021

VALVE ASSEMBLY, SOLENOID (YN35V00052F1) (HC415)

| REF FN | PART NUMBER | YR/SN | QTY DESCRIPTION |
|--------|----------------|-------|--|
| | YN35V00052F1 | | AR VALVE Solenoid Assembly |
| 1 | NA | | 1 NOT SERVICED Spool |
| 2 | NA | | 1 NOT SERVICED Sleeve |
| 3 | NA | | 1 NOT SERVICED Spring |
| 4 | NA | | 1 NOT SERVICED Ring, Retaining |
| 5 | YN35V00004S361 | | 1 O-RING |
| 6 | YN35V00004S362 | | 1 O-RING |
| 7 | YN35V00004S363 | | 1 O-RING |
| 8 | NA | | 1 NOT SERVICED Solenoid |
| 9 | YN35V00018S802 | | 1 NUT |
| 10 | ZD12P02000 | | 1 O-RING 19.8mm ID x 24.6mm OD x 2.4mm Thk ID 19.80 ± 0.22 x OD 24mm |
| 11 | NA | | 1 NOT SERVICED Name Plate |
| 12 | NA | | 1 NOT SERVICED Name Plate |

E215B-CRAWLER EXCAVATOR - TIER 3 (NA) - ASN N7DA21001

8.022

00

p2

4/2021

CYLINDER ASSEMBLY, BOOM (YN01V00151F1) (HC600)

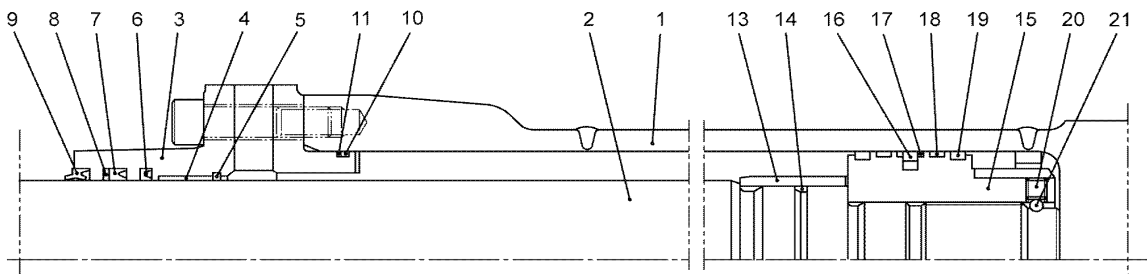
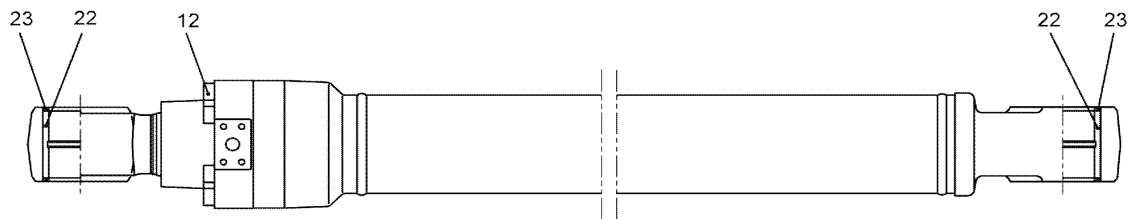

8.024

01

p1

4/2021

CYLINDER ASSEMBLY, ARM (EXTREME REACH) (YN01V00132F4)

| REF FN | PART NUMBER | YR/SN | QTY DESCRIPTION |
|--------|----------------|-------|---|
| | YN01V00132F4 | | AR HYDRAULIC CYLINDER Arm (Extreme Reach) |
| 3 | YN01V00105S003 | | 1 CYLINDER HEAD |
| 4 | 2438U1018S4 | | 1 BUSHING |
| 5 | 2438U776S5 | | 1 SNAP RING |
| 6 | YN01V00132S037 | | 1 BACK-UP RING |
| 7 | YN01V00105S007 | | 1 RING |
| 8 | YN01V00105S008 | | 1 BACK-UP RING |
| 9 | YN01V00105S009 | | 1 RING |
| 10 | ZD12G13000 | | 1 O-RING 129.40mm ID x 135.60mm OD x 3.10mm ID 129.40 ± 1.05 x OD 135mm |
| 11 | LQ01V00001S011 | | 1 RING |
| 12 | ZS23C18080 | | 12 CAPSCREW Hex Socket Head, M18 x 2.50 x 80mm SCREW M18x2.50x80mm |
| 13 | YN01V00105S013 | | 1 BUSHING |
| 14 | YN01V00105S014 | | 1 SEAL |
| 15 | YN01V00105S015 | | 1 PISTON |
| 16 | LQ01V00001S016 | | 1 RING |
| 17 | LQ01V00001S017 | | 2 BACK-UP RING |
| 18 | YN01V00105S018 | | 2 RING |
| 19 | LQ01V00001S019 | | 2 RING |
| 20 | 2438U1170S20 | | 1 SHIM |
| 21 | YN01V00118S021 | | 1 NUT |
| 22 | 2438U953S21 | | 1 SET SCREW |
| 23 | 2436R624S6 | | 1 BALL |
| 24 | YN01V00105S024 | | 1 LOCK NUT |
| 25 | LQ01V00007S025 | | 1 SEAL |
| 26 | 2438U1104S25 | | 2 STOP |
| 27 | 2438U1104S26 | | 1 RING |
| 29 | 2438U1102S26 | | 4 SEAL |

E215B-CRAWLER EXCAVATOR - TIER 3 (NA) - ASN N7DA21001

8.025

01

p3

4/2021

CYLINDER ASSEMBLY, BUCKET (YX01V00005F1, F2, F3, F4 & F5)

YX01V00005F1, F2, F3, F4, F5

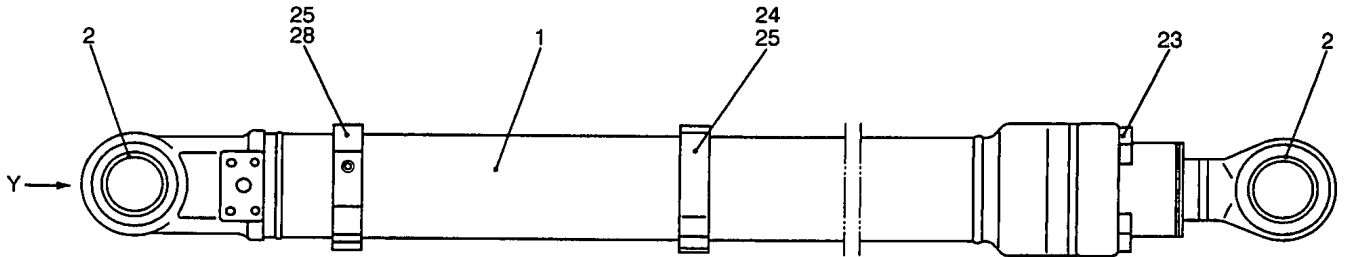

THIS FIGURE SHOWS F1

VIEW Y

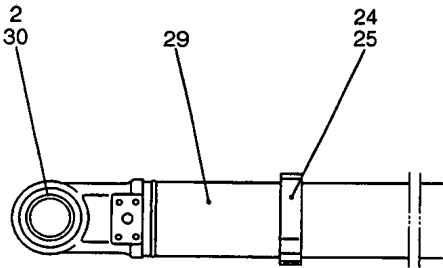

THIS FIGURE SHOWS F2, F4, F5

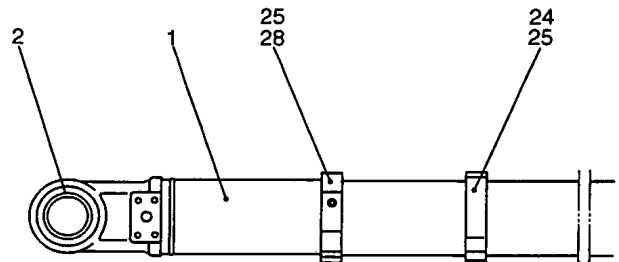

THIS FIGURE SHOWS F3

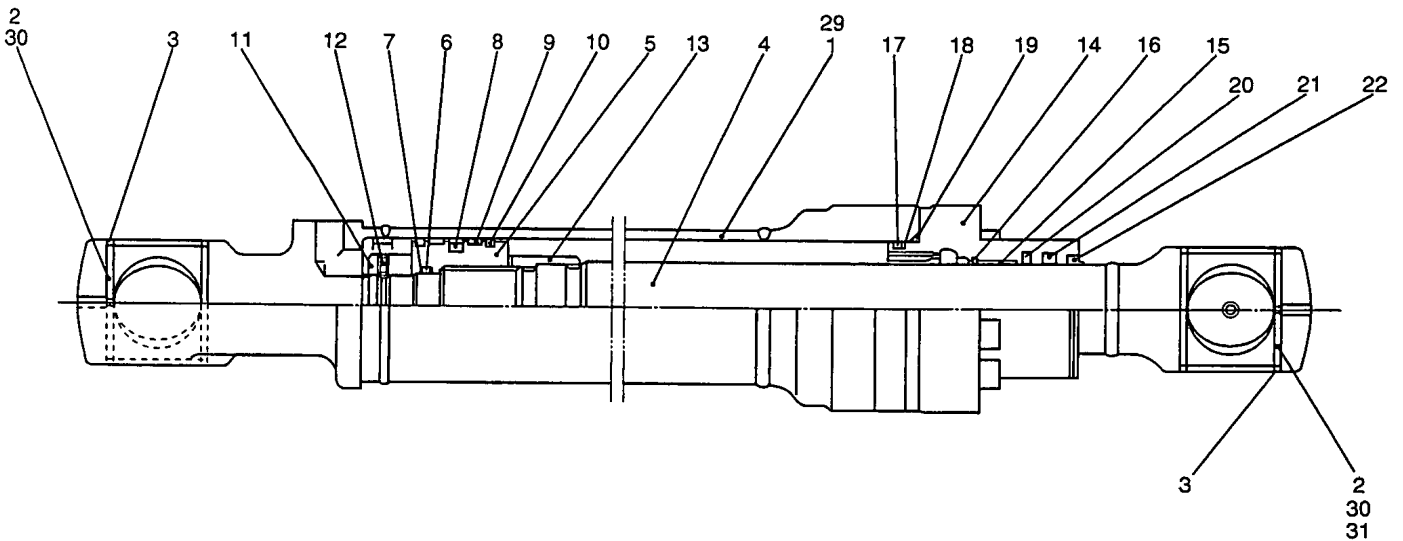

8.026

00

p2

4/2021

VALVE ASSEMBLY, PILOT (YN30V00080F1 & YN30V00080F2) (HC825)

| REF FN | PART NUMBER | YR/SN | QTY DESCRIPTION |
|--------|----------------|-------|---|
| 28 | ZD12P01100 | | 1 O-RING 10.8mm ID x 15.6mm OD x 2.4mm Thk ID 10.80 ± 0.18 x OD 15mm |
| 29 | YN30V00080S029 | | 2 O-RING |
| 31 | 2436U1354S26 | | 2 PISTON |
| 32 | NA | | 2 NOT SERVICED Spool |
| 33 | 2436U1354S4 | | 2 SPRING (F2 Only) |
| K | YN30V00080R200 | | 1 REPAIR KIT Contains Items 16, 25 & 32 |

E215B-CRAWLER EXCAVATOR - TIER 3 (NA) - ASN N7DA21001

8.031

00

p1

4/2021

VALVE ASSEMBLY, SOLENOID (YN35V00051F1) (HC854)

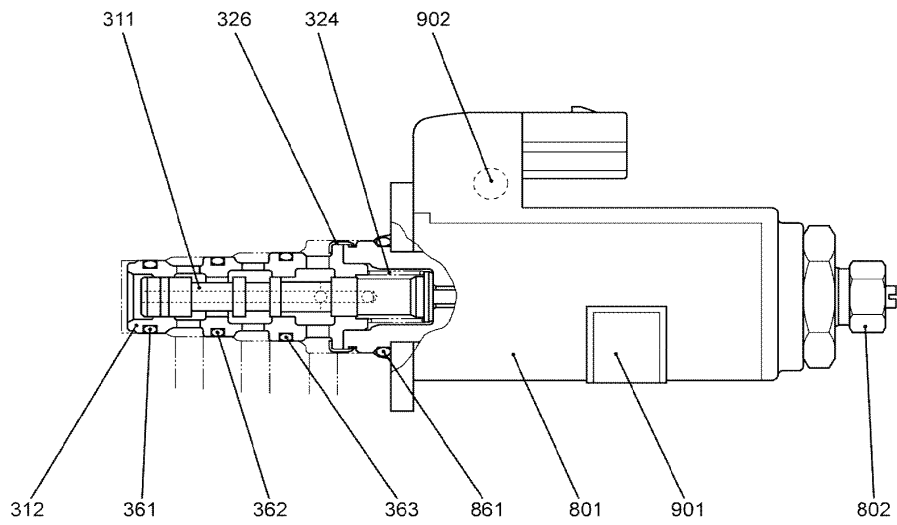

8.036

00

p1

4/2021

VALVE ASSEMBLY, SELECTOR (YN30V00113F1) (HC881)

| REF FN | PART NUMBER | YR/SN | QTY DESCRIPTION |
|--------|----------------|-------|---|
| | YN30V00113F1 | | AR VALVE Assembly, Selector |
| 1 | YN30V01033P1 | | 1 HOUSING |
| 2 | {YN30V01037P1} | | 1 Spool |
| 3 | YN30V01040P1 | | 1 COVER Cover |
| 4 | YN30V01064P1 | | 1 COVER |
| 5 | ZD12G05500 | | 2 O-RING 54.4mm ID x 60.6mm OD x 3.1mm Thk O-Ring -- ID 54.40 ± 0.49 x OD 60mm |
| 6 | ZD11P02800 | | 1 O-RING 27.7mm ID x 34.7mm OD x 3.5mm Thk ID 27.70 ± 0.28 x OD 34mm |
| 7 | ZS28C06016 | | 4 SCREW Hex Socket Head, M6 x 1.0 x 16mm M06x1.0x16mm |
| 8 | ZS28C06020 | | 4 SCREW Hex Socket Head, M6 x 1.0 x 20mm M06x1.0x20mm |
| 9 | YN30V01027P1 | | 4 PLUG |
| 10 | 2420Z1036D3 | | 2 CLEVIS 2.2mm OD x 4.6mm L 2.2x4.6mm |
| 11 | ZE82T02000 | | 8 PLUG 1/8" PT 1.25" PT |
| 12 | YN30V01015P1 | | 1 BALL |
| 13 | YN30V01028P1 | | 1 SPRING |
| 14 | {YN22T00264P1} | | 1 Name Plate |
| 15 | ZS28C06010 | | 1 CAPSCREW Hex Socket Head, M6 x 10mm SCREW M06x1.0x10mm |

E215B-CRAWLER EXCAVATOR - TIER 3 (NA) - ASN N7DA21001

8.039

00

p1

4/2021

JOINT ASSEMBLY, SWIVEL (YN55V00053F1) (HC930)

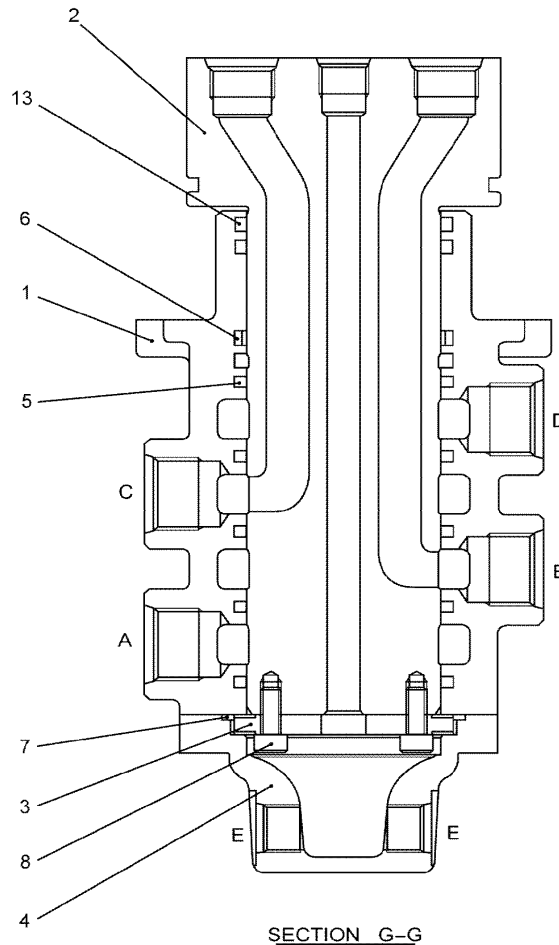
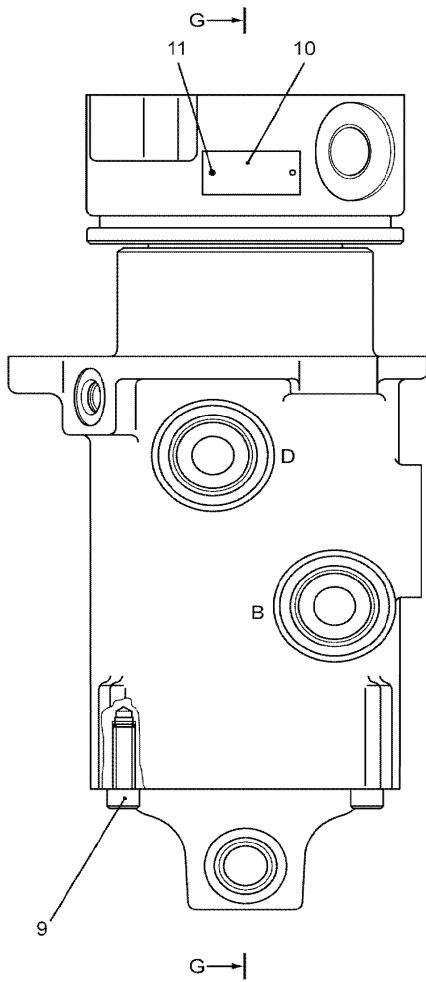
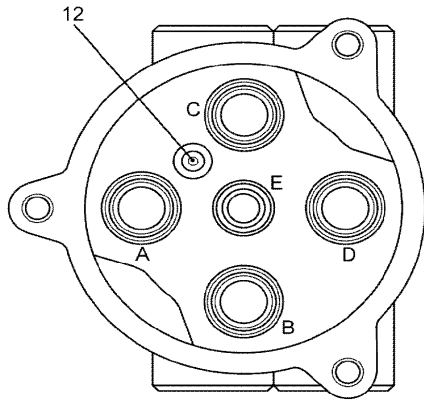

8.041

00

p3

4/2021

MOTOR ASSEMBLY, PROPELLING (YN15V00037F1), USED FROM DATE 03/31/2006 - 02/22/2008, FIGURE 1 OF 2

| REF FN | PART NUMBER | YR/SN | QTY DESCRIPTION |
|--------|------------------|-------|---|
| 167 | NSS | | 2 NOT SOLD SEPARAT Pivot |
| 301 | YN15V00037S301 | | 1 FLANGE |
| 341 | YN15V00017S033 | | 1 PIN |
| 345 | 2436U1427S25 | | 15 PLUG |
| 368 | 2436U1317S13 | | 2 PLUG |
| 369 | ZD12P01100 | | 2 O-RING 10.8mm ID x 15.6mm OD x 2.4mm Thk ID 10.80 ± 0.18 x OD 15mm |
| 374 | YN15V00017S038 | | 5 PLUG |
| 375 | ZD12P00800 | | 6 O-RING 7.8mm ID x 11.6mm OD x 1.9mm Thk ID 07.80 ± 0.16 x OD 11mm |
| 377 | YN15V00017S017 | | 3 CHECK VALVE |
| 378 | YN15V00017S026 | | 3 SPRING |
| 379 | ZD12P01600 | | 1 O-RING 15.8mm ID x 20.6mm OD x 2.4mm Thk ID 15.80 ± 0.20 x OD 20mm |
| 380 | YN15V00037S380 | | 1 O-RING |
| 397 | {2483U254S19} | | 1 Name Plate |
| 398 | {YN15V00037S398} | | 4 Rivet |
| 399 | {YN15V00037S399} | | 1 Name Plate |
| K | YN15V00037R400 | | 1 PISTON Kit, Repair -- Contains Items 105 & 106 |
| K | YN15V00037R410 | | 1 PISTON Kit, Repair -- Contains Items 161 & 163 |
| K | YN15V00037R420 | | 1 PLATE Kit, Repair -- Contains Items 103 & 167 |
| K | YN15V00037R430 | | 1 VALVE Kit, Repair -- Contains Items 301, 323, 341, 343, 345 & 363-380 |
| K | YN15V00037R440 | | 1 VALVE Kit, Repair -- Contains Items 323, 326-328 & 331 |
| K | YN15V00037R450 | | 1 SEAL KIT Contains Items 31, 132, 135, 139, 329, 369, 371, 375, 379 & 380 |

E215B-CRAWLER EXCAVATOR - TIER 3 (NA) - ASN N7DA21001

8.042

00

p4

4/2021

MOTOR ASSEMBLY, PROPELLING (YN15V00037F2), USED FROM DATE 02/22/2008 - UP, FIGURE 1 OF 2

MOTOR ASSY (PROPELLING)

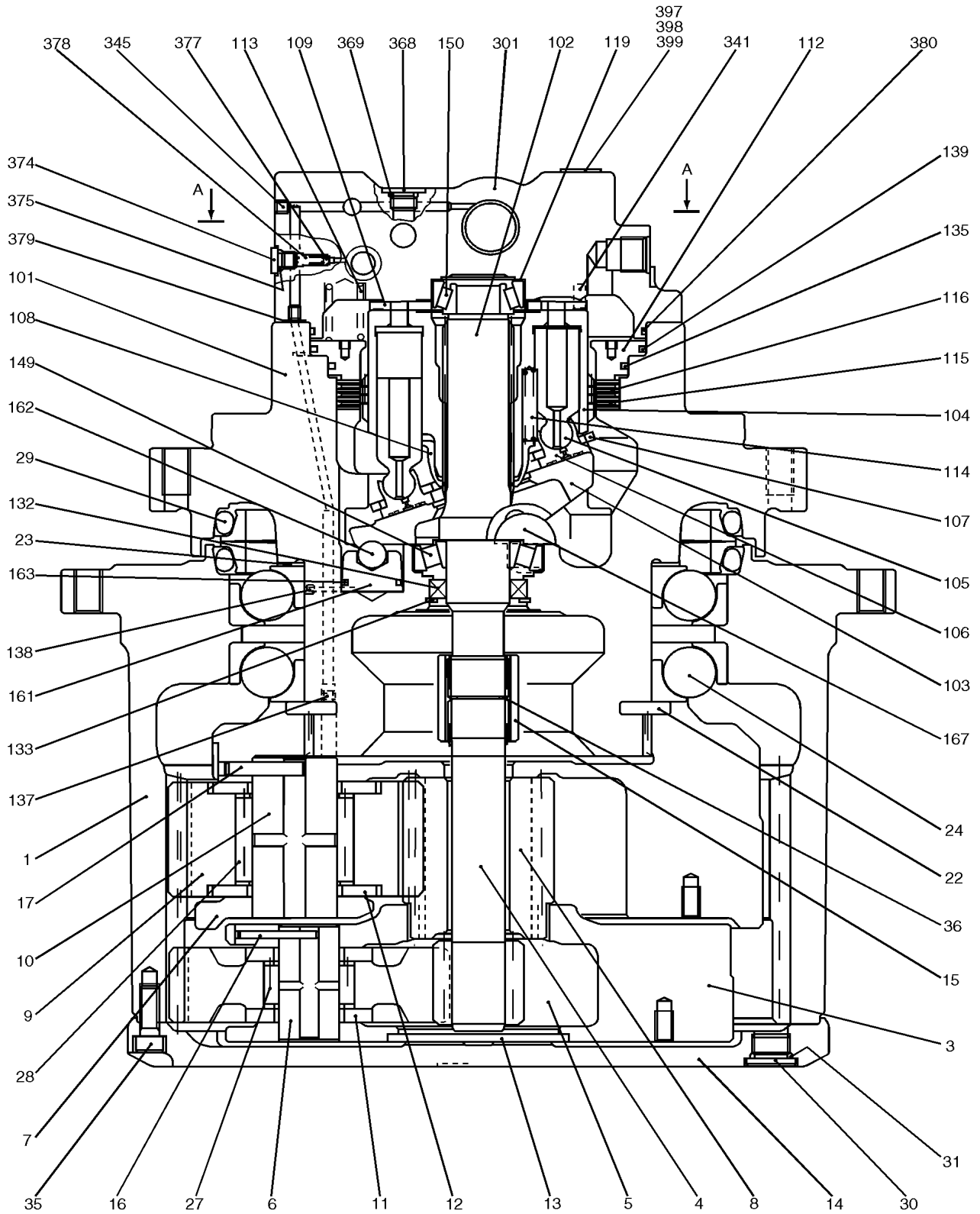

8.043

00

p3

4/2021

MOTOR ASSEMBLY, PROPELLING HC370 (LQ15V00020F1), FIGURE 1 OF 2

| REF FN | PART NUMBER | YR/SN | QTY DESCRIPTION |
|--------|----------------|-------|--|
| 53 | LQ15V00020S053 | | 1 PISTON Brake Biston |
| 54 | 2441U984S42 | | 1 O-RING |
| 55 | 2441U983S130 | | 1 O-RING |
| 56 | 2441U792S130 | | 6 SPRING |
| 57 | YN15V00005S128 | | 4 PIN Pin |
| 58 | YN15V00005S139 | | 2 SPRING |
| 59 | LQ15V00020S059 | | 1 PLATE Valve plate |
| 60 | ZD12P01000 | | 4 O-RING 9.8mm ID x 13.6mm OD x 1.9mm Thk ID 09.80 ± 0.17 x OD 13mm |
| 61 | 2441U802S30 | | 1 O-RING |
| 62 | NA | | 1 NOT SERVICED Name Plate |
| 63 | NA | | 2 NOT SERVICED Screw, Drive |
| 64 | NA | | 2 NOT SERVICED Plug |
| 65 | NA | | 1 NOT SERVICED Plug |
| 66 | NA | | 1 NOT SERVICED Plug |
| 67 | LQ15V00020S067 | | 2 SEAL Seal, Floating |
| 68 | LQ15V00007S077 | | 2 BALL BEARING |
| 69 | NA | | 1 NOT SERVICED Housing |
| 70 | NA | | 1 NOT SERVICED Shim (0.05) |
| 71 | LQ15V00020S071 | | 1 RUBBER RING Holder |
| 72 | LQ15V00007S081 | | 8 FRICTION WASHER |
| 73 | LQ15V00007S082 | | 8 SCREW |
| 74 | LQ15V00020S074 | | 4 PLATE Thrust Plate |
| 75 | LQ15V00007S084 | | 4 RACE |
| 76 | LQ15V00020S076 | | 4 NEEDLE BEARING Needle Bearing |
| 77 | LQ15V00007S086 | | 4 DRIVEN GEAR |
| 78 | LQ15V00020S078 | | 4 PLATE Thrust Plate |
| 79 | LQ15V00007S088 | | 4 SCREW |
| 80 | LQ15V00020S080 | | 1 GEAR Sun Gear |

E215B-CRAWLER EXCAVATOR - TIER 3 (NA) - ASN N7DA21001

8.043

01

p4

4/2021

MOTOR ASSEMBLY, PROPELLING HC370 (LQ15V00020F1), FIGURE 2 OF 2

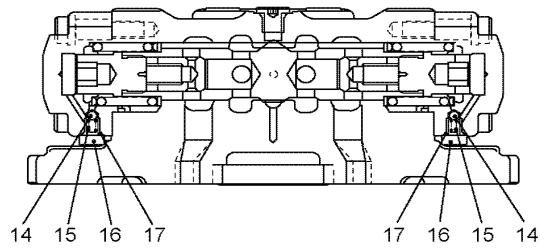
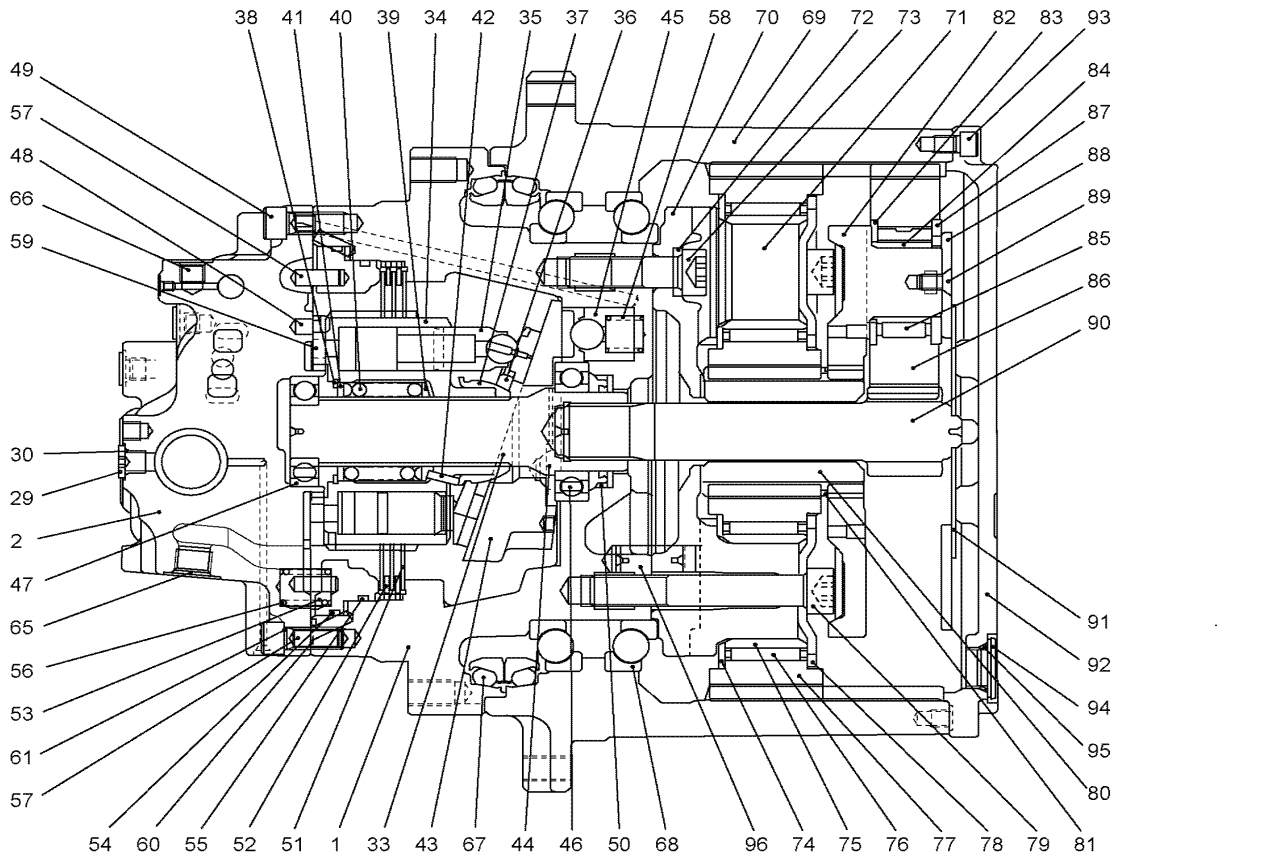

SECTION X1-X1

VALVE ASSEMBLY, CONTROL (YN30V00101F1, F2 & F3), FIGURE 2 OF 5

| REF FN | PART NUMBER | YR/SN | QTY DESCRIPTION |
|--------|----------------|-------|---|
| | ∅ | | Control Valve Assembly, Figure 2 of 5 |
| | YN30V00101F1 | | AR VALVE, CONTROL Assembly |
| | YN30V00101F2 | | AR CONTROL VALVE Assembly |
| | YN30V00101F3 | | AR CONTROL VALVE Control Valve Assembly |
| 1 | NA | | 1 NOT SERVICED Body |
| 2 | NA | | 1 NOT SERVICED Body |
| 3 | YN30V00001S154 | | 3 PLUG |
| 4 | YW30V00001S155 | | 2 PLUG PT 1/2" |
| 6 | NA | | 5 NOT SERVICED Plug |
| 8 | ZD12G03000 | | 15 O-RING 29.40mm ID x 35.60mm OD x 3.10mm ID 29.4 ± 0.29 x OD 35mm |
| 9 | ZD12P01500 | | 11 O-RING 14.8mm ID x 19.6mm OD x 2.4mm Thk ID 14.80 ± 0.20 x OD 19mm |
| 10 | ZD12P02400 | | 19 O-RING 23.7mm ID x 30.7mm OD x 3.5mm Thk ID 23.70 ± 0.24 x OD 30mm |
| 11 | ZD12P01800 | | 2 O-RING 17.8mm ID x 22.6mm OD x 2.4mm Thk ID 17.80 ± 0.21 x OD 22mm |
| 18 | YN30V00101S207 | | 1 GUARD |
| 25 | ZD12G04000 | | 10 O-RING 39.40mm ID x 45.60mm OD x 3.10mm ID 39.40 ± 0.37 x OD 45mm |
| 26 | ZD12P00700 | | 4 O-RING 6.8mm ID x 10.6mm OD x 1.9mm Thk |
| 30 | ZS23C08035 | | 5 SCREW Hex Socket Head, M8 x 1.25 x 35mm M08x1.25x35mm |
| 60 | YN30V00101S517 | | 1 HYDRAULIC VALVE |
| 61 | YN30V00101S518 | | 1 HYDRAULIC VALVE |
| 66 | YN30V00101S527 | | 1 SPRING |
| 67 | YN30V00101S528 | | 1 SPRING |
| 78 | ZS23C14160 | | 8 SCREW Hex Socket Head, M14 x 160mm M14x2.0x160mm |
| 79 | ZS23C14140 | | 2 SCREW Hex Socket Head, M14 x 2.0 x 140mm M14x2.0x140mm |

E215B-CRAWLER EXCAVATOR - TIER 3 (NA) - ASN N7DA21001

8.044

04

p2

4/2021

VALVE ASSEMBLY, CONTROL (YN30V00101F1, F2 & F3), FIGURE 4 OF 5

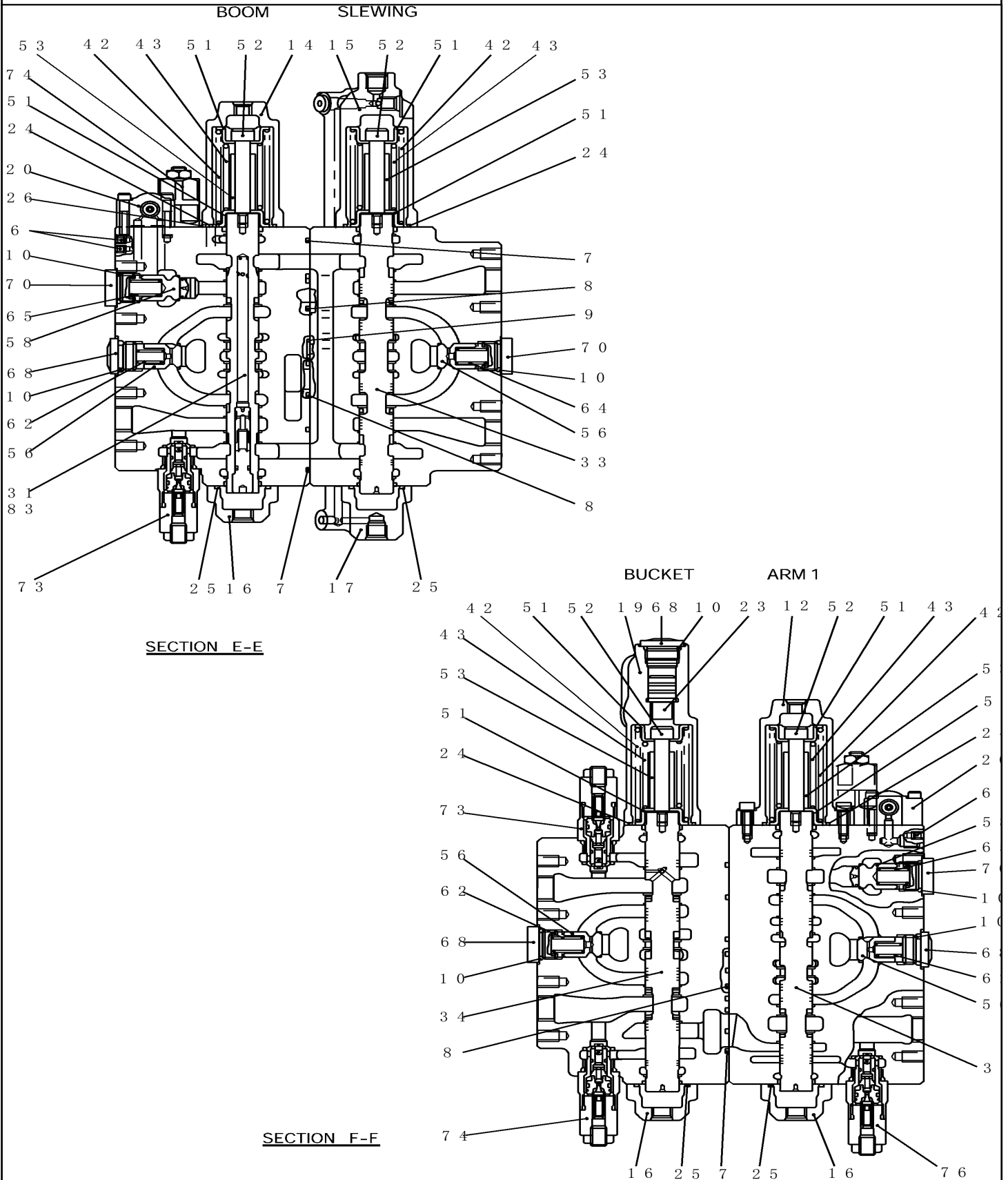

5.019

00

p3

4/2021

HYDRAULIC LINES, ARM 2.94M (9FT 8IN) (NIBBLER & BREAKER) (YN43H00204F1)

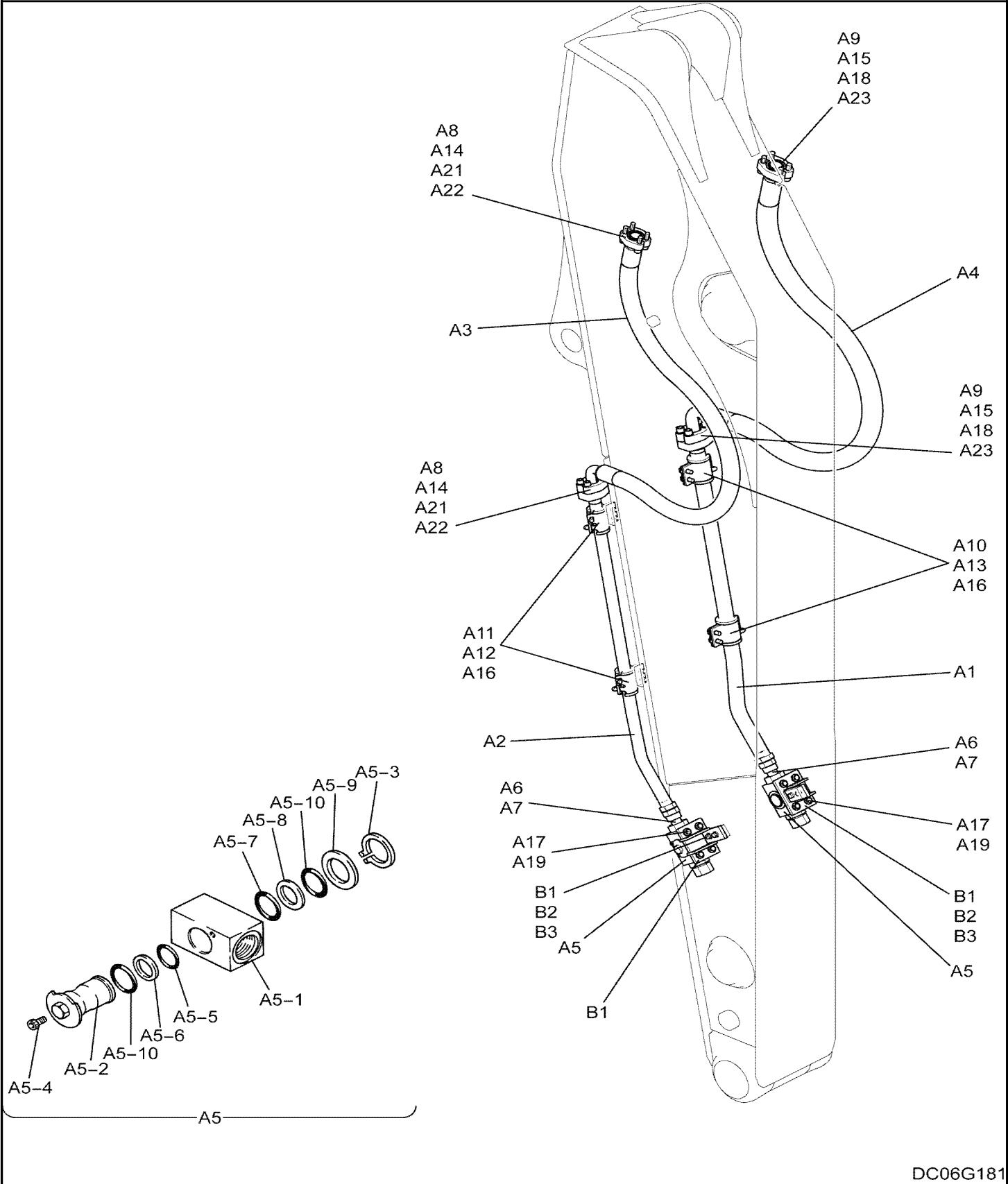

5.022

00

p1

4/2021

ARM (ROTATION + NIBBLER & BREAKER) (YN12B00827F1)

| REF FN | PART NUMBER | YR/SN | QTY DESCRIPTION |
|--------|--------------|-------|---|
| | ⌋ | | Arm (Rotation + Nibbler & Breaker), YN12B00827F1 |
| 1 | YN12B00828F1 | | 1 ARM Arm |
| 2 | 2445R220D4 | | 2 SEAL 78.7mm ID x 95mm OD x 5mm Thk Dust -- ID 70 x OD 85 x Th 5mm |
| 3 | 2445R220D3 | | 2 SEAL 70mm ID x 85mm OD x 5mm Thk Dust -- ID 70 x OD 85 x Th 5mm |
| 4 | 2445R138D8 | | 2 SEAL 90mm ID x 105mm OD x 4mm Thk Dust -- ID 90 x OD 105 x Th 4mm |

E215B-CRAWLER EXCAVATOR - TIER 3 (NA) - ASN N7DA21001

5.025

00

p2

4/2021

HYDRAULIC LINES, BOOM CYLINDER (HOLDING VALVE) (YN42H00338F1)

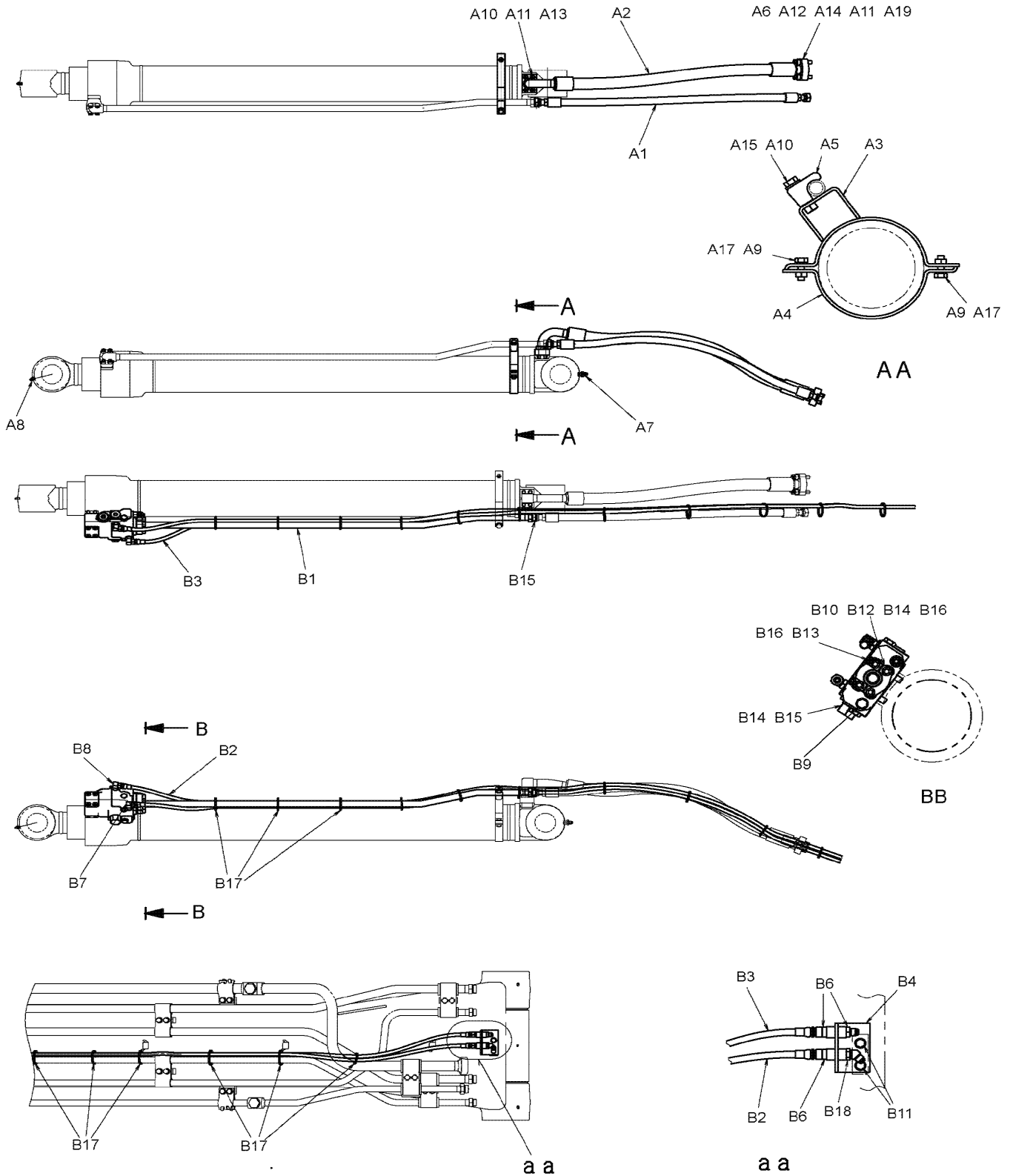

DC06J028

5.026

00

p4

4/2021

HYDRAULIC LINES, CYLINDER (BOOM & ARM HOLDING VALVE) (YN42H00352F1), FIGURE 1 OF 2

| REF FN | PART NUMBER | YR/SN | QTY DESCRIPTION |
|--------|--------------|-------|---|
| C14 | ZD12A02100 | | 2 O-RING 23.52mm ID x 27.08mm OD x 1.78mm Thk ID 23.52 ± 0.15 x OD 27.08mm |
| C15 | YY42H01330P1 | | 2 O-RING 0.07" Thk x 0.301" ID, -11, CI 5, 75 Duro ID 7.65 ± 0.12 x OD 11.21mm |
| C16 | YN52S00048P1 | | 1 SENSOR 0 - 50MPa, 3 Terminal, PF 3/8" Pressure (High Pressure) (Incls. O-Ring ZD12P01400) |
| | ZD12P01400 | | 1 O-RING 13.8mm ID x 18.6mm OD x 2.4mm Thk (Part of YN52S00048P1), ID 13.80 ± 0.19 x OD 18mm, Not Shown |
| C17 | ZS28C12040 | | 8 SCREW Hex Socket Head, M12 x 1.75 x 40mm |
| C18 | ZS28C12075 | | 8 SCREW Hex Socket Head, M12 x 75mm Screw -- M12x1.75x75mm |
| C19 | ZW26K12000 | | 8 LOCK WASHER 12mm ID x 17.8mm OD x 2.5mm Thk ID 12 x OD 17.8 x Th 2.5mm |
| C20 | PY01P01043D6 | | 10 CABLE TIE 4.8mm W x 383mm L Wire Ties -- 368mm Long |
| C21 | PU13E01010D8 | | 3 PROTECTIVE SLEEVE 15mm ID x 19mm OD x 850mm L ID 15.2 x OD 19.5 x 850mm Long |

E215B-CRAWLER EXCAVATOR - TIER 3 (NA) - ASN N7DA21001

5.027-01

00

p2

4/2021

HYDRAULIC LINES, CYLINDER (BOOM) (YN42H00412F1)

ART

NOT

AVAILABLE

5.031

00

p1

4/2021

HYDRAULIC LINES, PROPEL (HIGH & WIDE) (YN12HU0001F1)

| REF FN | PART NUMBER | YR/SN | QTY DESCRIPTION |
|--------|-------------|-------|---|
| | ⌋ | | Propel Hydraulic Lines (High & Wide), YN12HU0001F1, Incls. Refs. 1-5 |
| 1 | ZG23F12016 | | 4 HYD CONNECTOR 1 3/16" - 12UN x PF 1" x 53mm L 1 3/16" 12UN-1" PT x 48mm Long (Incls. O-Ring 237-6016) |
| | 237-6016 | | 1 O-RING 0.116" Thk x 1.171" ID, -916, CI 6, 90 Duro (Part of ZG23F12016), SAE No. 16-1, Not Shown |
| 2 | ZH22X08000 | | 2 HYD CONNECTOR Male, 30 Deg FI, PF 1/2" x PF 1/2" x 46mm L, O-Ring (Incls. O-Ring ZD12P01800) |
| | ZD12P01800 | | 1 O-RING 17.8mm ID x 22.6mm OD x 2.4mm Thk (Part of ZH22X08000), ID 17.80 ± 0.21 x OD 22mm, Not Shown |
| 3 | 2444Z2525 | | 2 HYD CONNECTOR PF 1/4" x PF 1/4" x 35mm L 1/4"PFx35mm Long (Incls. O-Ring ZD12P01100) |
| | ZD12P01100 | | 1 O-RING 10.8mm ID x 15.6mm OD x 2.4mm Thk (Part of 2444Z2525), ID 10.80 ± 0.18 x OD 15mm, Not Shown |
| 4 | ZH32X04000 | | 2 90 ELBOW Male, 30 Degree FI, PF 1/4" x PF 1/4", O-Ring Elbow, 90° -- (Incls. O-Ring 237-6004) |
| | 237-6004 | | 1 O-RING 0.072" Thk x 0.351" ID, -904, CI 6, 90 Duro (Part of ZH32X04000), SAE No. 4-1, Not Shown |
| 5 | ZD12A01800 | | 4 O-RING 18.77mm ID x 22.33mm OD x 1.78mm Thk ID 18.77 ± 0.12 x OD 22.33mm |

E215B-CRAWLER EXCAVATOR - TIER 3 (NA) - ASN N7DA21001

6.021

00

p1

4/2021

HYDRAULIC LINES, BOOM (LONG REACH) (YN42H00342F1)

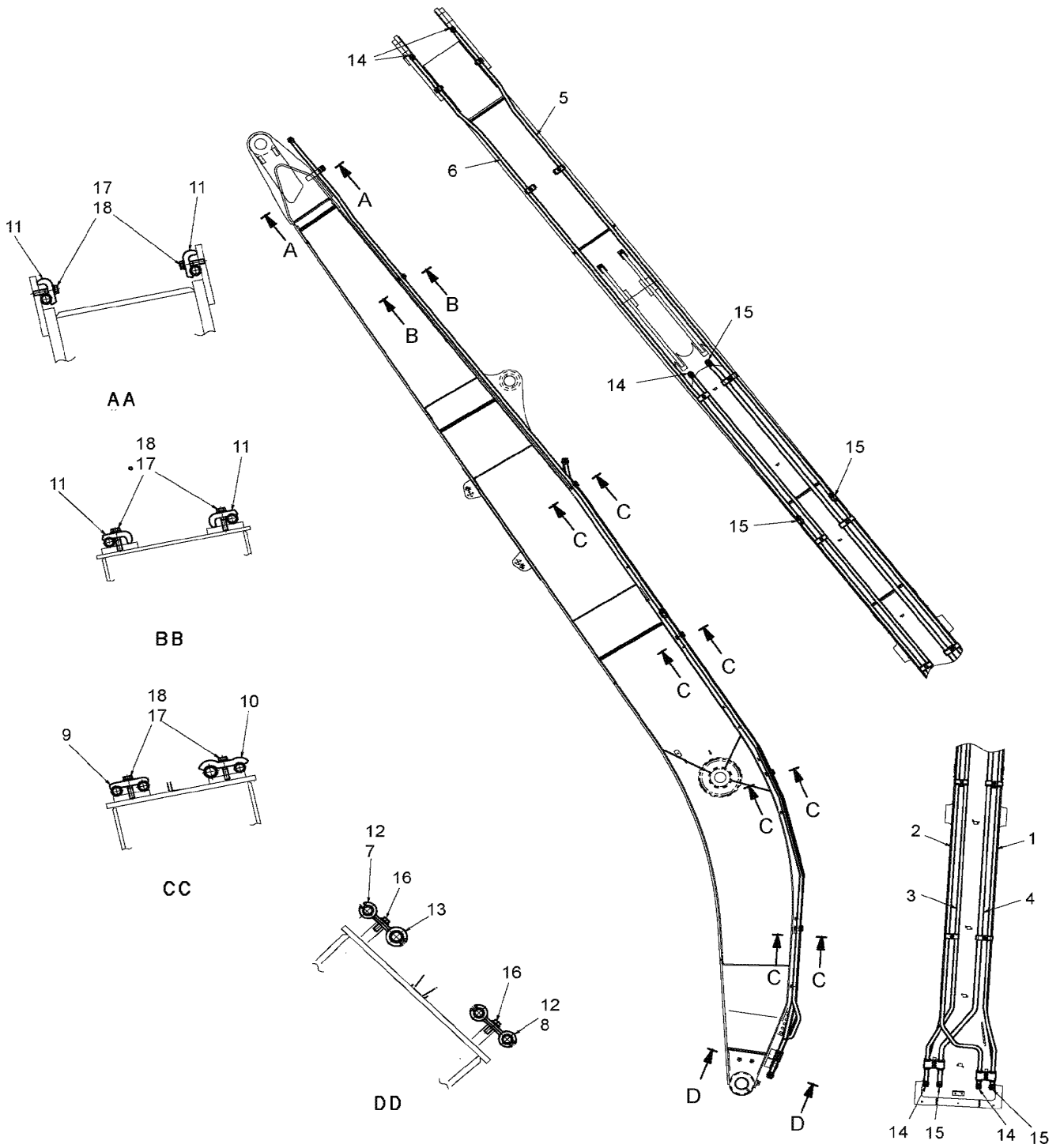

DC06J091

6.026

00

p1

4/2021

ARM GROUP (LONG REACH) (YN12B00439F4)

| REF FN | PART NUMBER | YR/SN | QTY DESCRIPTION |
|--------|---------------|-------|--|
| | ⌋ | | Arm Group (Long Reach), YN12B00439F4 |
| 2 | YY12B01074P1 | | 1 LINK |
| 3 | YW12B01034P1 | | 1 LINK |
| 4 | YN12B01719P1 | | 2 PIN 68mm OD x 470mm L OD 65 x 470mm Long |
| 5 | YN12B01720P1 | | 1 PIN 60mm OD x 366mm L OD 60 x 366mm Long |
| 6 | YN12B01721P1 | | 1 PIN 60mm OD x 366mm L OD 60 x 366mm Long |
| 7 | 2444R1117D150 | | 1 HOSE 6.4mm ID x 1500mm L |
| 8 | 2444R1117D180 | | 2 HOSE 6.4mm ID x 1800mm L |
| 9 | 2444R1117D195 | | 1 HOSE 6.40mm ID x 1950mm L |
| 10 | YN12B01157P1 | | 1 BRACKET |
| 11 | ZH32Z04002 | | 2 90 ELBOW Male, 30 Deg Fl, PF 1/4" x PF 1/8" 90° -- 1/4" PF - 1/8" PT |
| 12 | ZG91S02000 | | 6 LUBE NIPPLE Straight, PT 1/8" 1/8" PT -- Straight |
| 13 | ZG91U02000 | | 1 LUBE NIPPLE 90 deg, PF 1/8" 90°x1/8" PT |
| 14 | 2445R220D2 | | 4 SEAL 65mm ID x 80mm OD x 5mm Thk Dust -- ID 65 x OD 80 x Th 5mm |
| 16 | 2445R220D6 | | 2 SEAL 90mm ID x 105mm OD x 6mm Thk Dust -- ID 90 X OD 105 x Th 6mm |
| 17 | YN12B01610D1 | | 6 SHIM 62mm ID x 100mm OD x 2.0mm Thk ID 62 x OD 100 x Th 2.0mm |
| 18 | B16T0442D56 | | 6 SHIM 62mm ID x 100mm OD x 0.5mm Thk (M62 ID x 100 OD) |
| 19 | B16T0442D43 | | 6 SHIM 62mm ID x 100mm OD x 0.9mm Thk (M62 ID x 100 OD) |
| 20 | B16T0442D19 | | 6 SHIM 62mm ID x 100mm OD x 1.6mm Thk ID 62 x OD 100 x Th 1.6mm |
| 21 | YN12B01153P1 | | 2 SHIM 38mm ID x 210mm OD x 6.0mm Thk 210 x 38 x Th 6.0mm |

E215B-CRAWLER EXCAVATOR - TIER 3 (NA) - ASN N7DA21001

CLICK HERE TO **DOWNLOAD** THE COMPLETE MANUAL

- Thank you very much for reading the preview of the manual.
- You can download the complete manual from: www.heydownloads.com by clicking the link below



- Please note: If there is no response to CLICKING the link, please download this PDF first and then click on it.

CLICK HERE TO **DOWNLOAD** THE COMPLETE MANUAL