

1-1

# W11B Loader Parts Catalog

Bur 8-1883

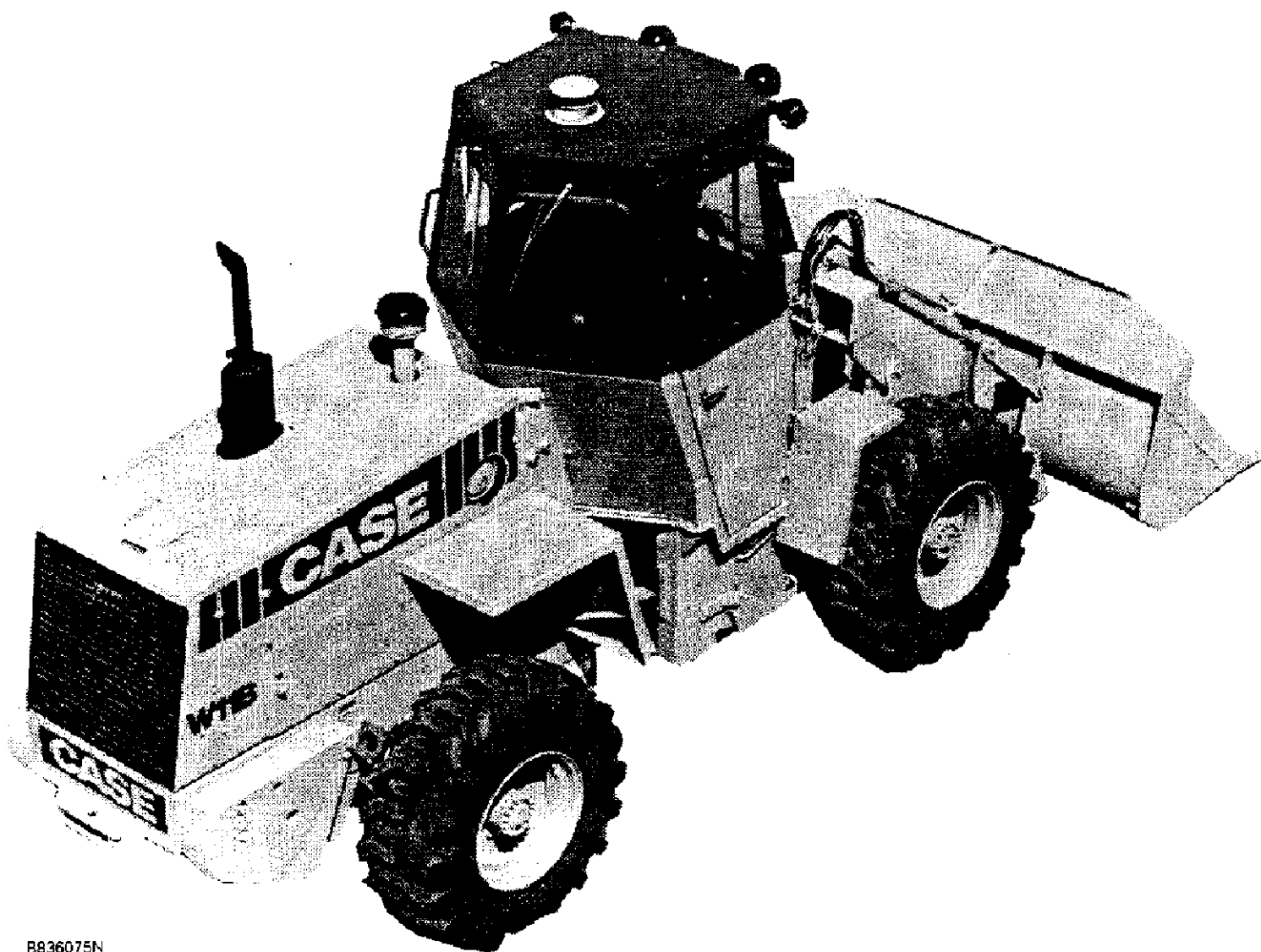

B836075N

Bur 8-1883

Issued July, 1989

Printed in U.S.A.

CLICK HERE TO **DOWNLOAD** THE COMPLETE MANUAL

- Thank you very much for reading the preview of the manual.
- You can download the complete manual from: [www.heydownloads.com](http://www.heydownloads.com) by clicking the link below



- Please note: If there is no response to CLICKING the link, please download this PDF first and then click on it.

CLICK HERE TO **DOWNLOAD** THE COMPLETE MANUAL

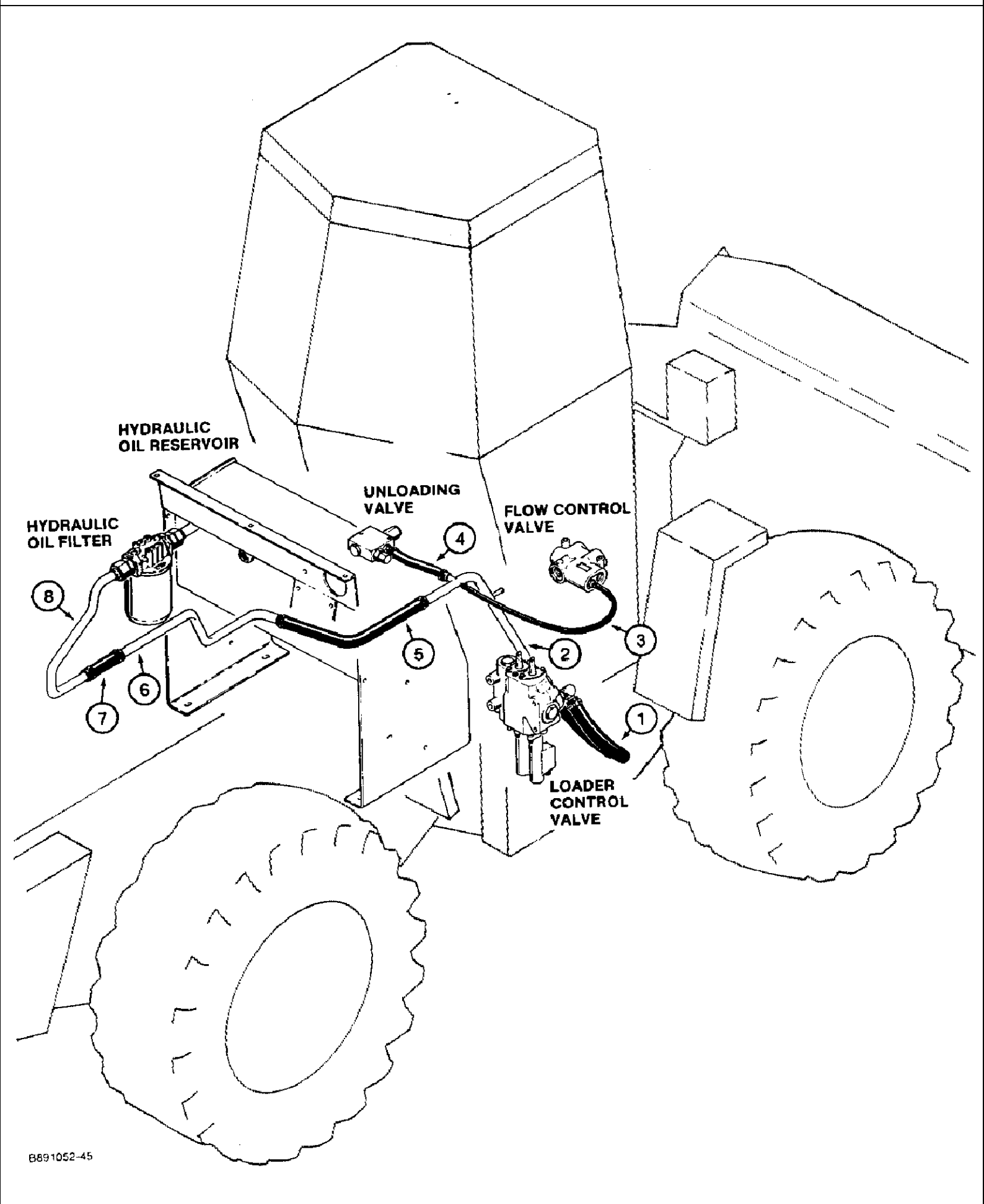

## W11B CASE UNIT LOADER - Engine

## 2-004 FRONT GEAR COVER, 4-390 ENGINE, 4T-390 ENGINE

Ref	Part Number	Qty	Description
1	J903794	1	COVER - gear, front
2	NSS	1	SEAL - oil, crankshaft front (Order Ref. 30)
3	J914385	1	GASKET - front cover (Replaces J910500)
4	J910411	1	HOUSING - timing gear
5	J916131	1	GASKET - gear housing (Replaces J907836)
6	J900633	10	BOLT - hex, 8 mm - 1.25 x 50 mm
7	J900629	16	BOLT - hex, 8 mm - 1.25 x 16 mm
10	J900257	2	PIN - dowel, locating, 16 mm
11	J905933	1	HOUSING - timing pin (Replaces J903923)
12	J914092	1	O-RING - pin housing (Replaces J906693)
13	J905595	1	GASKET - pin housing (Used with J903923 housing)
14	J907998	2	SCREW, LOCK, Spc Rd Torx Hd, M5 x 17
15	J903924	1	PIN - timing
16	J913994	1	O-RING - sealing (Replaces J903927)
17	J904849	1	Ring, Snap, 0.875", Int, #87, timing pin
18	J913192	1	GASKET - cover plate (Replaces A77441)
19	J901249	2	BOLT - hex flange, 12 mm - 1.75 x 25 mm
20	J909918	1	PLATE - cover, access (Replaces A77440)
23	J905218	1	GASKET - tachometer drive (If equipped)
24	J905217	1	ADAPTER - drive (If equipped)
25	J915064	1	COVER - tachometer drive (If equipped) (Replaces J903476)
26	J903475	1	SEAL - cover (If equipped)
27	J905306	1	HUB - tachometer drive (If equipped)
28	A77442	2	BOLT - tachometer drive (If equipped)
29	K651812	2	WASHER - retaining (If equipped)
30	J904353	1	SEAL KIT - oil, crankshaft front, Includes: Ref. 31 - 33
31	NSS	1	SEAL - oil, crankshaft front
32	NSS	1	TOOL - seal installation
33	NSS	1	TOOL - seal installation
34	J912772	1	RETAINER - bolt
35	J901446	1	BOLT - hex flange, 8 mm - 1.25 x 60 mm
36	J903463	1	COVER - tachometer drive hole
37	J903475	1	SEAL - cover

## W11B CASE UNIT LOADER - Engine

## 2-014 OIL PUMP AND OIL PAN, 4-390 ENGINE, 4T-390 ENGINE, ENGINE

Ref	Part Number	Qty	Description
	JR914005	1	PUMP - oil, remanufactured (North America only)
	JC914005	1	RETURN NUMBER - use this part number to return pump core for credit
1	J914005	1	PUMP ASSEMBLY - oil, engine (Replaces J906413)
2	813-8030	4	BOLT - hex, 8 mm - 1.25 x 30 mm
5	J905205	1	TUBE - suction, oil
7	J914383	1	GASKET - mounting, tube (Replaces J905468), Part of gasket kit P/N A77673
8	J900629	3	BOLT - hex, 8 mm - 1.25 x 16 mm
10	J901049	1	PAN - oil, engine
11	NSS	1	GASKET - oil pan (order A77482), Part of gasket kit P/N A77673
12	J900215	1	PLUG - drain, oil (Alternate with J911638 plug)
13	J911638	1	PLUG - drain, oil magnetic (Alternate with J900215 plug)
14	J900216	1	WASHER - seal, drain plug, Part of gasket kit P/N A77673
15	J907860	28	SCREW - hex flange head, 8 mm - 1.25 x 25 mm
16	J907537	28	WASHER - spring, pan bolt
17	J904386	1	PLUG - pipe
18	J902425	1	WASHER - seal, plug
	A77673	1	GASKET KIT - oil pan (Includes Refs. 7, 11 and 14) (Replaces A77482)
25	A77490	1	KIT - heater, engine oil, Includes: Ref. 26 and 27, When kit is ordered, J902425 washer, Ref. 28, must also be ordered.
26	NSS	1	ELEMENT - heater, 12 volt (Order A77490), engine oil heater
27	J905113	1	CABLE - heater electric, engine oil heater
28	J902425	1	WASHER - seal, engine oil heater

Had a dealer call with a different oil pan and pick up tube than shown here. Had J907570 pan and J905223 tube. Same as shown in 688 Exc catalog.

## W11B CASE UNIT LOADER - Engine

## 2-024 CYLINDER BLOCK, 4-390 ENGINE, ENGINE BLOCK HEATER

Ref	Part Number	Qty	Description
37	J905440	1	TUBE - oil fill
38	J906696	1	O-RING - sealing, 38 mm ID
39	J901249	2	BOLT - hex flange, 12 mm - 1.75 x 25mm
40	A77424	1	CAP ASSEMBLY - fill, oil
44	J903102	1	CONNECTION - water inlet
45	J906697	1	O-RING - sealing, 50 mm ID
46	J901757	3	BOLT - hex flange head, 10 mm - 1.50 x 75 mm
47	A77429	2	PLUG - hex socket pipe, 1/2 inch PT
50	J906593	1	HOSE - breather
51	J904230	1	CLAMP - spring, hose
52	J904231	1	CLIP - hose (If equipped)
53	J905479	1	NUT - spring, hose clip (If equipped)
54	J909670	1	CLIP - retaining
55	L112785	1	TUBE - oil fill (If equipped)
56	L61111	1	CAP - oil fill tube (If equipped)
57	S98707	1	O-RING - sealing, 44 mm ID (If equipped)
58	814-12030	3	BOLT - hex, 12 mm - 30 mm (If equipped)
59	892-11012	3	WASHER, LOCK, M12 (If Equipped)
	A77634	1	HEATER KIT - engine block, Includes: Ref. 60 and 61
60	NSS	1	ELEMENT - engine heater, 12 volt, engine block heater
61	J905113	1	CABLE - engine block heater
62	J910517	1	O-RING - heater sealing, engine block heater

## W11B CASE UNIT LOADER - Engine

## 2-034 PISTONS, 4-390 ENGINE, CONNECTING RODS

Ref	Part Number	Qty	Description
	A77460		KIT - piston, engine, standard, Includes: Ref. 1 - 7
1	A77401	1	RING KIT - piston (Standard), Includes: Ref. 2 - 4
2	NSS	1	RING - compression (Top)
3	NSS	1	RING - compression (Middle)
4	NSS	1	RING - oil (Bottom)
5	NSS	1	PISTON - engine (Standard) (Stamped 6223)
6	J901793	1	PIN - piston
7	J901706	2	RING - retainer, pin
	A77461		KIT - piston, engine (0.5 mm oversize), Includes: Ref. 10 - 16
10	A77463	1	RING KIT - engine (0.5 mm oversize), Includes: Ref. 11 - 13
11	NSS	1	RING - compression (Top)
12	NSS	1	RING - compression (Middle)
13	NSS	1	RING - oil (Bottom)
14	NSS	1	PISTON - engine (0.5 mm oversize) (Stamped 6209)
15	J901793	1	PIN - piston
16	J901706	2	RING - retainer, pin
	A77462		PISTON KIT - engine (1.0 mm oversize), Includes: Ref. 20 - 26
20	A77464	1	RING KIT - engine (1.0 mm oversize), Includes: Ref. 21 - 23
21	NSS	1	RING - compression (Top)
22	NSS	1	RING - compression (Middle)
23	NSS	1	RING - oil (Bottom)
24	NSS	1	PISTON - engine (1.0 mm oversize) (Stamped 6208)
25	J901793	1	PIN - piston
26	J901706	2	RING - retainer, pin
30	J904166		UAR LINER - piston (Used only in engine block repair) (When liner is installed, use only A77410 Piston Kit)
	JR901569		UAR ROD ASSEMBLY - connecting, remanufactured (North America only), Includes: Ref. 36 and 37
	JC901569		UAR RETURN NUMBER - use this part number to return connecting rod for credit, Includes: Ref. 36 and 37
35	J901569	4	ROD ASSEMBLY - connecting, new, Includes: Ref. 36 and 37
36	NSS	1	BUSHING - rod to piston pin (Order J901569), connecting rods
37	J900919	2	BOLT - hex special, 11 mm - 1.25 x 59 mm, connecting rods
40	A77465	4	BEARING KIT - connecting rod (set, upper and lower, standard), connecting rods
40	A77466	4	BEARING KIT - connecting rod (set, upper and lower, 0.25 mm undersize), connecting rods
40	A77467	4	BEARING KIT - connecting rod (set, upper and lower, 0.5 mm undersize), connecting rods
40	A77468	4	BEARING KIT - connecting rod (set, upper and lower, 0.76 mm undersize), connecting rods
40	A77469	4	BEARING KIT - connecting rod (set, upper and lower, 1.0 mm undersize), connecting rods

4-390 engine used prior to engine S/N 44117591. High compression 18.5/1 ratio.

## W11B CASE UNIT LOADER - Engine

## 2-044 RADIATOR, FAN, AND BELT

Ref	Part Number	Qty	Description
1	A171322	1	RADIATOR - engine cooling
2	A170241	1	CAP, FILLER, radiator, 15 PSI
3	L111554	1	SHROUD - fan , REF: 3-1 For use on Funk Transm. , BSN 9164337
3A	L118157	1	SHROUD - fan , Ref. 3A-1 For use on Clark Transm. , ASN 9164337
4	L112260	1	GUARD - fan , Ref. 4-1 For use on Funk Transm. , BSN 9164337
4A	L118134	1	GUARD - fan , Ref. 4A-1 For use on Clark Transm. , ASN 9164337
5	814-8016	14	BOLT - hex, 8 mm - 1.25 x 16 mm
6	892-1108	16	WASHER - lock, 8 mm
7	895-11008	14	WASHER - flat, 9 x 17 x 2 mm
7A	825-1108	2	NUT - hex, 8 mm
8	113-3	3	BOLT, Hex, 1/4"-20 x 3/4", G5, Full Thd
9	195-102	6	WASHER - flat, 5/16 x 3/4 x 1/16 inch
10	86625061	3	NUT - hcx lock, 1/4 inch NC
11	L111138	2	BRACKET - upper radiator support
12	614-8020	4	BOLT - hex, 8 mm - 1.25 x 20 mm
13	892-1108	2	WASHER - lock, 8 mm
14	895-11008	2	WASHER - flat, 9 x 17 x 2 mm
15	A170665	2	STRAP - radiator mounting
16	413-620	4	BOLT - hex, 3/8 NC x 1-1/4 inch
17	492-11038	4	3/8"
18	495-21044	8	WASHER - flat, 7/16 x 1 x 5/64 inch
19	129-103	4	NUT, 3/8"-16, G5
20	814-8025	4	BOLT - hex, 8 mm - 1.25 x 25 mm
21	892-1108	4	WASHER - lock, 8 mm
22	895-11008	4	WASHER - flat, 9 x 17 x 2 mm
23	L111137	2	BRACKET - radiator mounting
24	113-233	2	BOLT, Hex, 3/8"-16 x 1 3/4", G5
25	D52276	2	CUSHION - rubber
26	D52275	2	WASHER - flat, 25/64 x 1-1/4 x 7/64 inch, hardened
27	195-528	2	WASHER - flat, 3/8 inch
	495-21044	2	WASHER - flat, 7/16 x 1 x 5/64 inch
29	131-217	2	NUT - hex, self-locking, 3/8 inch NC, grade 8
30	L13809	1	HOSE - drain
31	A27862	1	VALVE - drain
32	REF	2	SEAL - 19-1/8 inch (485 mm) long, cut from A162397, see below
33	REF	2	STRIP - radiator sides, 25-3/16 inch (640 mm) long, cut from L35756, see below
34	REF	2	STRIP - radiator, upper and lower, 22" (559 mm) long, cut from L35756, see below
	A162397		UAR SEAL - bulk, 180 inch (4572 mm) long
	L35756		UAR STRIP - foam, bulk roll, 50 foot (15.24 m) long

2-54

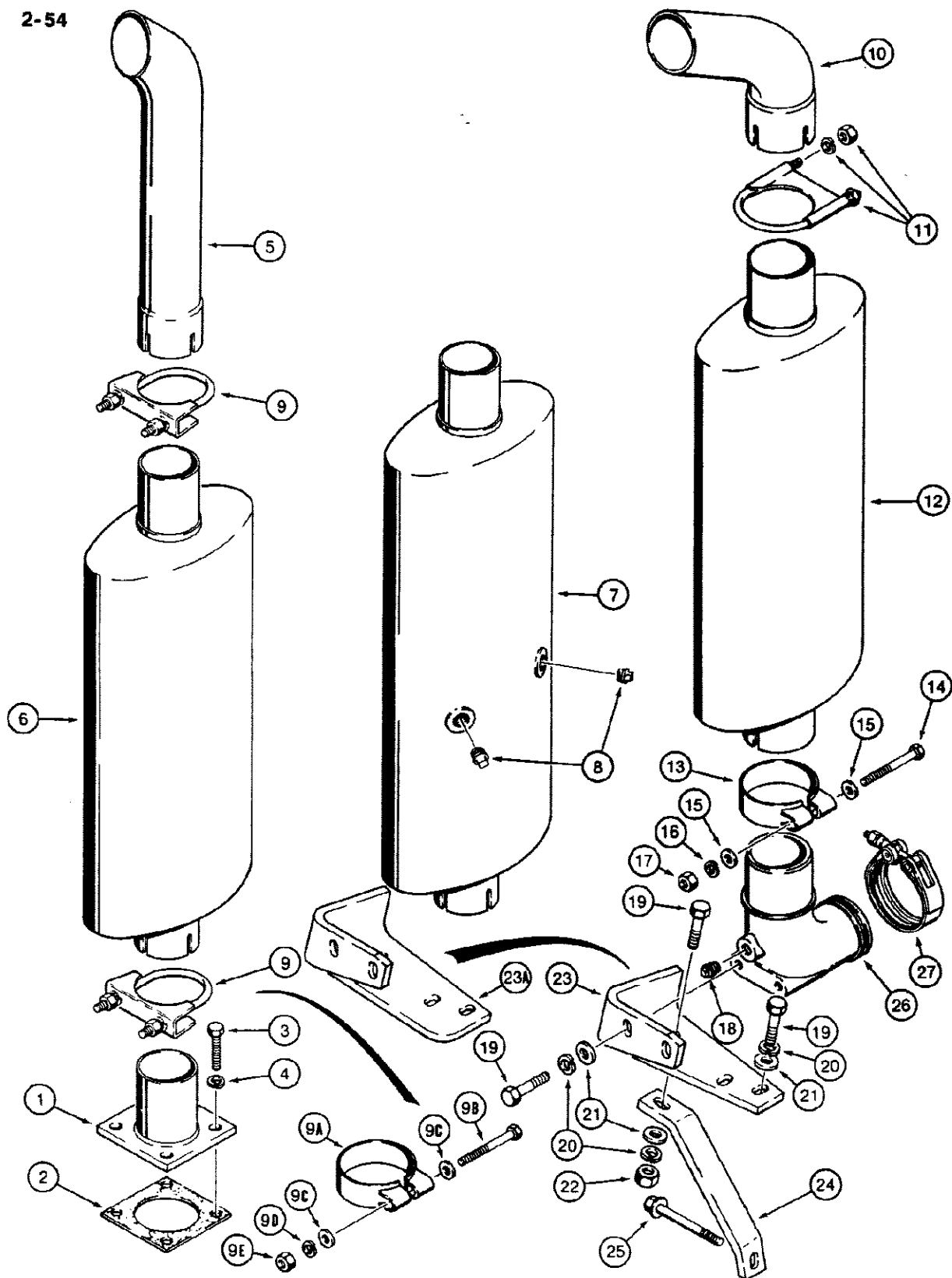

831175D-45

## W11B CASE UNIT LOADER - Fuel System

## 3-006 FUEL INJECTION SYSTEM, 4-390 ENGINE

Ref	Part Number	Qty	Description
1	J904374	1	PUMP ASSEMBLY - lift, fuel
3	J914304	1	GASKET - fuel lift pump (Replaces J904044)
4	J900630	2	BOLT - hex flange head, 8 mm - 1.25 x 20 mm (Replaces J900631)
5	J905649	1	TUBE ASSEMBLY - fuel, lift pump to filter, Includes: Ref. 6
6	NSS	1	SEAL - tube
7	J903035	1	BOLT - banjo hex, 12 mm - 1.5 x 24 mm
8	J903037	4	WASHER - sealing, 12 x 18 x 1 mm
10	J905364	1	TUBE ASSEMBLY - fuel supply, filter to tee, Includes: Ref. 11
11	222-103	1	SLEEVE - tube, 5/16 inch (Replaces J905351)
12	J905353	1	TEE - union, 9/16-24 NF thread
	222-663	3	NUT - hex, 1/2-24 inch thread (Discard before assembly)
14	J905375	1	TUBE ASSEMBLY - fuel supply, tee to rear of injection pump, Includes: Ref. 15
15	222-103	1	SLEEVE - tube, 5/16 inch (Replaces J905351)
17	J905363	1	TUBE ASSEMBLY - fuel supply, tee to front of injection pump, Includes: Ref. 18
18	222-103	1	SLEEVE - tube, 5/16 inch (Replaces J905351)
	J905860	1	BOLT - banjo hex, special, Includes: Ref. 19 and 20
19	NSS	1	BOLT - connector, banjo hex special (Order J905860)
20	NSS	1	SCREW - hex special, vent (Order J905860)
26	J909695	1	MANIFOLD ASSEMBLY - fuel return
27	222-121	1	TEE - union, 3/16 inch tube
	222-661	3	NUT - hex, 3/8-24 inch thread (Discard before assembly)
29	J905703	1	TUBE ASSEMBLY - fuel return, tee to pump, Includes: Ref. 30
30	222-103	1	SLEEVE - tube, 5/16 inch (Replaces J905391)
31	J905692	1	TUBE ASSEMBLY - fuel return, tee to fuel tank, Includes: Ref. 32
32	222-101	1	SLEEVE - for 3/16 inch tube (Replaces J905391)
35	J905307	4	BOLT - banjo drain, special
36	J903380	4	SEAL - connector
37	REF	4	INJECTOR ASSEMBLY - fuel (See Figure 3-21)
38	J900808	4	SEAL - injector
40	J903522	1	TUBE ASSEMBLY - fuel injector, No. 1 cylinder
41	J903523	1	TUBE ASSEMBLY - fuel injector, No. 2 cylinder
42	J903524	1	TUBE ASSEMBLY - fuel injector, No. 3 cylinder
43	J903525	1	TUBE ASSEMBLY - fuel injector, No. 4 cylinder
	A77484	1	BRACKET ASSEMBLY - injection supply tube No. 1 and 2, Includes: Ref. 45 - 49
45	NSS	1	BRACKET - fuel tube
46	J914338	2	ISOLATOR - supply tube
47	NSS	1	PLATE - clamp, fuel tube
48	NSS	1	WASHER - lock, 5 mm
49	NSS	1	BOLT - hex head
	A77485	1	BRACKET ASSEMBLY - injection supply tube No. 3 and 4, Includes: Ref. 50 - 55
50	NSS	1	BRACKET - fuel tube

## W11B CASE UNIT LOADER - Fuel System

## 3-014 FUEL INJECTION PUMP AND DRIVE, 4-390 ENGINE

Ref	Part Number	Qty	Description
	JR908657	1	PUMP ASSEMBLY - fuel injection, remanufactured (North America) only), Includes: Ref. 2 - 18
	JC908657	1	RETURN NUMBER - use this part no. to return pump core for credit, Includes: Ref. 2 - 18
1	J908657	1	PUMP ASSEMBLY - fuel injection, new (Metric Thread) (Replaces J903336), used with Funk transmission, Includes: Ref. 2 - 18
	JR908656	1	PUMP ASSEMBLY - fuel injection, remanufactured (North America only), Includes: Ref. 2 - 18
	JC908656	1	RETURN NUMBER - use this part no. to return pump core for credit, Includes: Ref. 2 - 18
1	J908656	1	PUMP ASSEMBLY - fuel injection (Metric Thread), used with Clark transmission, Includes: Ref. 2 - 18
2	J904637	1	SCREW - adjusting, low idle
3	K963867	1	SCREW ASSEMBLY - bleed, pump head
4	J904646	4	BOLT - banjo
5	J904644	9	WASHER - sealing, package of ten, nine pieces required
6	K962755	4	FITTING - banjo
7	J904641	1	FITTING - inlet
8	K962748	1	WASHER - inlet fitting, copper
9	J904640	1	ORIFICE - bleed
10	J904643	1	FITTING - return
11	J904630	1	SOLENOID ASSEMBLY - shut down, 12 volt, Ref. 12 and 14 are included along with a NSS guide, Includes: Ref. 12
12	J904635	1	O-RING - solenoid
13	J902332	1	KEY - retainer, pump gear
14	J904777	1	SPRING - plunger
16	J904778	1	BOLT - hex, locking device
17	J904780	1	SEAL - locking bolt
18	J904779	1	WASHER - locking
20	J902501	3	STUD - pump mounting, 8 mm - 1.25 x 48 mm
21	J900589	3	NUT - hex flange, 8 mm
22	J914389	1	GASKET - pump mounting (Replaces J905685)
26	J914912	1	GEAR - pump drive (Replaces J911331)
27	192-24	1	WASHER, LOCK, 9/16" (Replaces 92-9)
28	J903738	1	NUT - hex, 14 mm
30	J905387	1	BRACE - fuel pump
31	J900630	3	BOLT - hex, 8 mm - 1.25 x 20 mm

4-390 engine with Lucas pump.

## W11B CASE UNIT LOADER - Fuel System

## 3-022 FUEL INJECTION NOZZLE, 4T-390 ENGINE, NOZZLE STAMPED 9476

Ref	Part Number	Qty	Description
12	1806258C1		UAR SHIM, 1.84mm Thk, Nozzle (5 in kit)
12	1806259C1		UAR SHIM, 1.88mm Thk, Nozzle (5 in kit)
12	1806260C1		UAR SHIM, 1.90mm Thk, Nozzle (5 in kit)
12	1806261C1		UAR SHIM, 1.94mm Thk, Nozzle (5 in kit)
12	1806262C1		UAR SHIM, 1.98mm Thk, Nozzle (5 in kit)

4-10

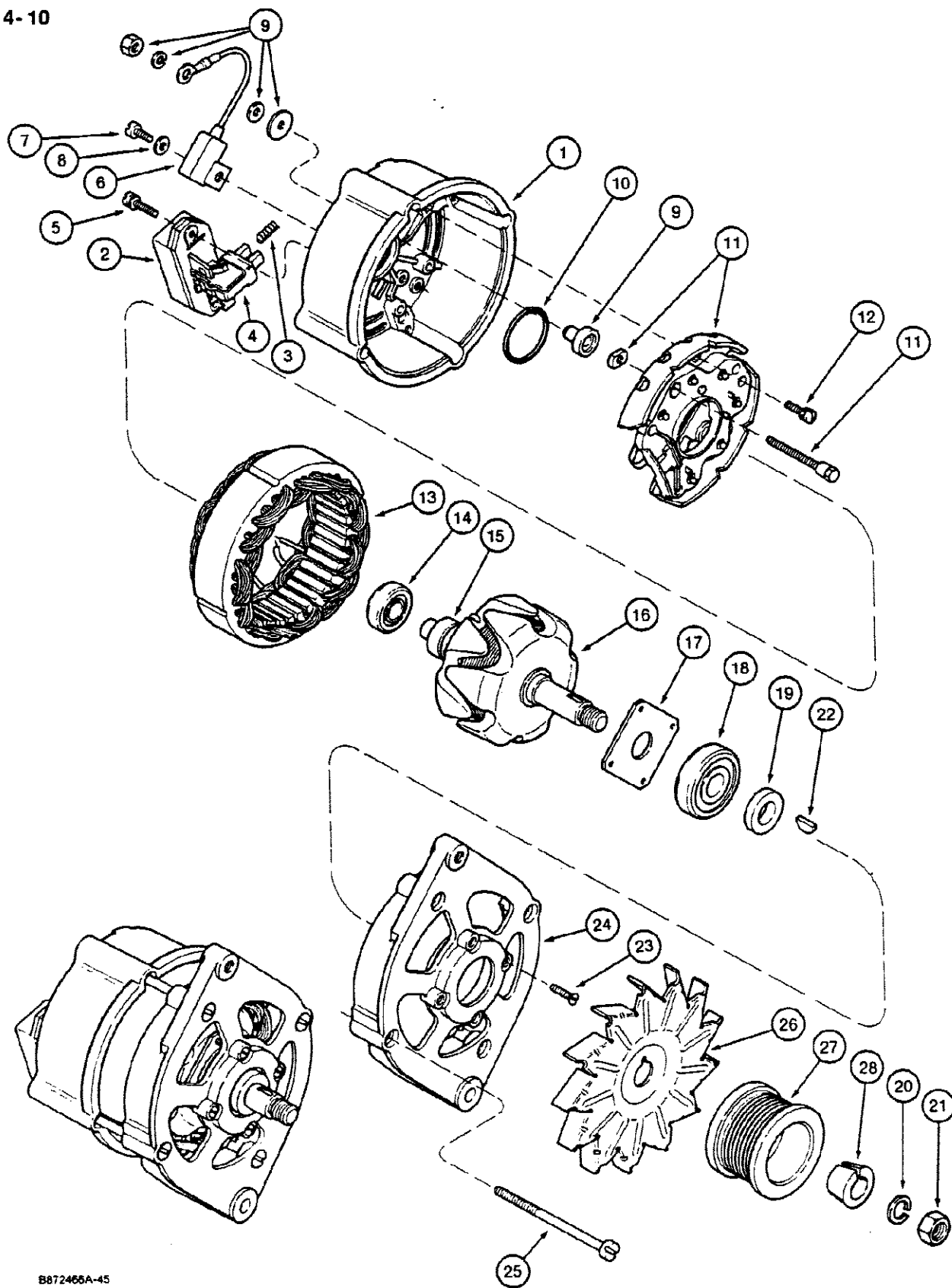

B872465A-45

4-20

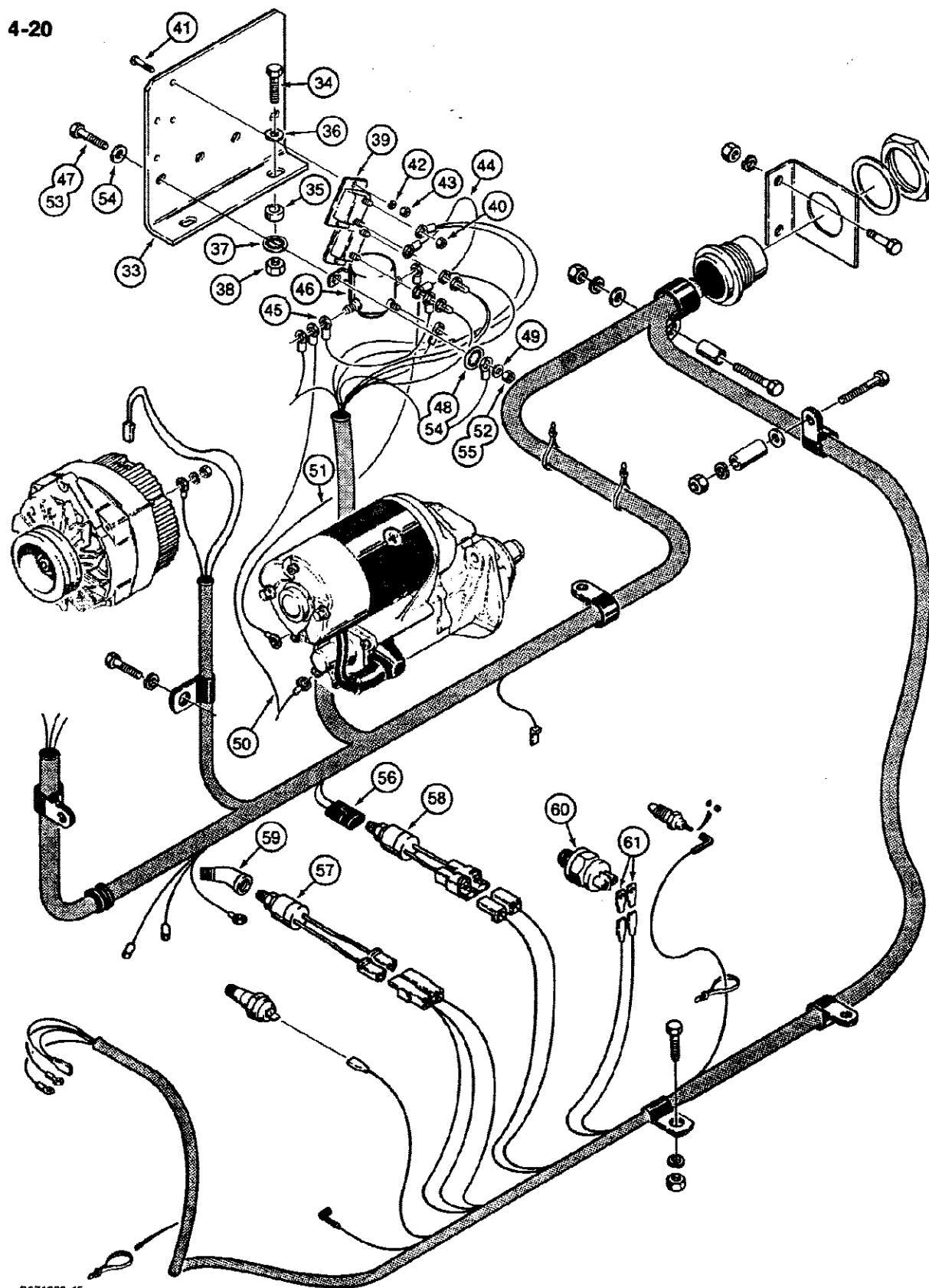

B871880-45

## W11B CASE UNIT LOADER - Electrical System

4-028 ELECTRICAL SYSTEM, REAR ELECTRICAL HARNESS, P.I.N. 9158252

Ref	Part Number	Qty	Description
44	129-17	1	NUT - hex, No. 10-24
45	129-37	4	NUT, #10-32
46	193-70	8	WASHER, LOCK, Ext-Int Tooth, #10
47	182-126	1	MACHINE SCREW - pan head slotted, No. 10 - 24 NC x 5/8"
48	193-73	2	WASHER - internal/external lock, 1/4 inch
49	L114233	2	CIRCUIT BREAKER - 40 amperes
50	182-90	4	MACHINE SCREW - pan head slotted, No. 8 -32 NC x 1"
51	49858	2	CLAMP - medium closed, 3/4 inch diameter
52	192-20	2	WASHER, LOCK, 5/16"
53	113-102	1	BOLT, Hex, 5/16"-18 x 3/4", G5, Full Thd
54	49858	1	CLAMP - medium closed, 3/4 inch diameter
55	113-207	1	BOLT, Hex, 3/8"-16 x 1", G5, Full Thd
56	492-11038	1	3/8"
57	129-103	1	NUT, 3/8"-16, G5
58	49836	1	CLAMP - harness
59	814-12020	1	BOLT - hex head, 12 mm - 1.75 x 20 mm (8.8), plated
60	892-11012	1	WASHER, LOCK, M12
61	L71879	1	DIODE - alternator protecting
62	192-16	3	Washer, Lock, #8
63	193-119	3	WASHER - internal-external tooth lock, No. 8, plated
64	193-70	1	WASHER, LOCK, Ext-Int Tooth, #10
65	L116235	1	SWITCH - backup alarm
66	221-1401	1	ELBOW - street, 45 degree, 1/8" NPT

## W11B CASE UNIT LOADER - Electrical System

4-038 ELECTRICAL SYSTEM, FRONT ELECTRICAL HARNESS, BEFORE P.I.N. 9158252

Ref	Part Number	Qty	Description
1	L113956	1	HARNESS - front electrical, Includes: Ref. 2 and 3
2	N7321	1	CONNECTOR - two pin
3	N7322	1	CONNECTOR - four pin
4	R14668	1	CLAMP - harness retaining
5	113-103	1	BOLT, Hex, 5/16"-18 x 1", G5, Full Thd
6	192-20	1	WASHER, LOCK, 5/16"
7	425-105	1	NUT - hex, 5/16 inch NC
8	L18337	2	STRAP - tie, 15 inch, nylon
9	L77823	1	GROMMET - rubber
10	A167492	1	RELAY - horn
11	163-12	1	MACHINE SCREW - hex head, No. 10 - 24 NC x 3/4"
12	192-18	1	WASHER, LOCK, #10
13	129-17	1	NUT - hex, No. 10-24
14	L18337		UAR STRAP - tie, 15 inch, nylon
15	D123205	1	HORN - electrical
16	193-36	1	WASHER, LOCK, Int Tooth, 7/8"
17	L73799	1	BRACKET - horn
18	L30866	1	NUT - horn
19	113-103	1	BOLT, Hex, 5/16"-18 x 1", G5, Full Thd
20	193-67	2	WASHER, LOCK, Int Tooth, 5/16" , Replaces regular lock washer used in production on some models
21	425-105	1	NUT - hex, 5/16 inch NC
22	L79085	1	WIRE - harness to stop light switch
23	S49603	1	SWITCH - stop light
24	113-207	1	BOLT, Hex, 3/8"-16 x 1", G5, Full Thd
25	49845	1	CLIP - retaining
26	492-11038	1	3/8"
27	129-103	1	NUT, 3/8"-16, G5
28	L103667	1	BUZZER - brake warning
29	182-510	1	MACHINE SCREW - No. 8 - 32 NC x 1/2"
30	193-191	1	WASHER - internal lock, no. 8, replaces regular lock washer used in production on some models
31	195-510	1	WASHER - plain, 3/16 x 7/16 inch

This figure is in reference to a Funk unit before P.I.N. 9158252. See page 6-28 and 6-29 for neutral start switch.

## W11B CASE UNIT LOADER - Electrical System

## 4-048 FRONT ELECTRICAL HARNESS, P.I.N. 9164337 AND AFTER

Ref	Part Number	Qty	Description
1	L123613	1	HARNESS - front electrical, Includes: Ref. 2 and 3
2	N7321	1	CONNECTOR - two pin
3	N7322	1	CONNECTOR - four pin
4	193-87	1	WASHER, LOCK, Ext-Int Tooth, 1/2"
5	113-103	2	BOLT, Hex, 5/16"-18 x 1", G5, Full Thd
6	192-20	2	WASHER, LOCK, 5/16"
7	425-105	2	NUT - hex, 5/16 inch NC
8	A37353	1	GROMMET - rubber
9	L115938	1	CONDUIT - electric
10	193-89	2	WASHER, LOCK, Ext-Int Tooth, #6
11	D134622	1	SWITCH - parking brake
12	192-105	2	NUT - hex, 1/2 inch NC
13	187-1719	2	SCREW - pan head, self-tapping, No. 6 - 32 NC x 1"
14	L77828	1	PLATE - switch mounting
15	187-1715	2	SCREW - pan head, self-tapping, No. 6 - 32 NC x 1/2"
16	L18337		UAR STRAP - tie, 15 inch, nylon
17	L115962	1	ALARM - parking brake
18	223-166	1	CONNECTOR - female
19	182-510	1	SCREW - machine, pan head slotted, no. 8 NC x 1/2 inch
20	195-510	1	WASHER - plain, 3/16 x 7/16 inch
21	193-91	1	WASHER, LOCK, Int Tooth, #8
22	S49603	1	SWITCH - stop light
23	L73799	1	BRACKET - horn
24	113-103	1	BOLT, Hex, 5/16"-18 x 1", G5, Full Thd
25	193-71	2	WASHER, LOCK, Ext-Int Tooth, 5/16"
26	425-105	1	NUT - hex, 5/16 inch NC
27	S203189	1	HORN - electric
28	193-122	1	WASHER - internal-external tooth lock, 7/8 inch, if used
29	L30866	1	NUT - special, horn mounting

This figure is in reference to Clark units.

## W11B CASE UNIT LOADER - Electrical System

4-058 ELECTRICAL SYSTEM, LEFT-HAND INSTRUMENT PANEL, BEFORE P.I.N. 9158252

Ref	Part Number	Qty	Description
1	L104321	1	INSTRUMENT PANEL - left-hand
2	182-149	4	SCREW - slotted, No. 10 - 32 NC x 1"
3	192-18	4	WASHER, LOCK, #10
4	L60362	4	NUT - special, No. 10 - 32 NC
5	L72776	1	SWITCH - cold start, if used, Includes: Ref. 6 - 9
6	NSS	1	BODY - switch
7	D73741	1	NUT - hex, special
8	H275784	1	NUT - special
9	173-93	2	SCREW - round head, No. 10 - 32 NF x 1/4"
10	L59682	2	TERMINAL - cold start switch, if used
11	353-407	1	PLUG - 11/16", if used
12	L74694	1	KNOB - strobe lamp switch, if used
13	A42561	1	NUT - strobe lamp switch, if used
14	L70872	1	SWITCH - strobe lamp, if used
15	353-404	2	PLUG, Dome, .500" hole, Nylon (13 mm)
16	L76929	2	CIRCUIT BREAKER - 12 amperes
17	L79086	1	CONNECTOR - blade type
18	169-97	1	SCREW - slotted, No. 10 - 24 NC x 1/2"
19	193-99		WASHER, LOCK, Int Tooth, #10, Replaces regular
		1	lock washer used in production on some models
20	129-7	1	NUT - hex, No. 10 - 24 NC
	L61053	1	SWITCH ASSEMBLY - key, Includes: Ref. 21 - 23
21	NSS	1	SWITCH - key
22	A77313	1	KEY - ignition
23	A77314	1	NUT - mounting
	L105210	1	LAMP - instrument panel, Includes: Ref. 24 and 25
24	NSS	1	BODY AND LENS - lamp
25	A22349	1	BULB - No. 363
26	L55654	1	SWITCH - lamp
27	L113462	1	HARNESS - left-hand instrument
28	193-37	1	WASHER, LOCK, Int Tooth, 1"
29	L76726	1	CIRCUIT BREAKER - auxiliary steering, if used, 3 amperes
30	L106421	1	HARNESS - auxiliary steering, if used

## W11B CASE UNIT LOADER - Electrical System

4-068 ELECTRICAL SYSTEM, REAR LAMPS AND BACKUP ALARM, BEFORE P.I.N 9158252

Ref	Part Number	Qty	Description
1	REF	1	HARNES - rear electrical, see Figures 4-18 - 4-24.
2	L76559	2	BRACKET - lamp
3	111-317	5-8	BOLT - hex head, 3/8" - 16 NC x 1", plated
4	193-68	5-8	WASHER, LOCK, Int Tooth, 3/8", Replaces regular lock washer used in production on some models
5	129-103	5-8	NUT, 3/8"-16, G5
6	49859	1	CLAMP - harness
7	D88684	1-2	LAMP - flood, sealed beam, parts list Figure 4-84
8	L76559	1	BRACKET - lamp
9	413-620	2	BOLT - hex, 3/8 NC x 1-1/4 inch
10	193-68	4	WASHER, LOCK, Int Tooth, 3/8"
11	129-103	2	NUT, 3/8"-16, G5
12	49853	3	CLAMP - harness
13	L76802	1	WIRE - harness to right-hand lamp, if used
14	REF	1	LAMP - stop and tail, see Figure 4-86 for correct lamp and component parts
15	129-125	1	NUT, 1/2"-20, G5
16	L78495	2	SHRINK TUBING - lamp to harness connection
17	80679	1	Washer, Lock, 1/2"
18	L109087	1	ALARM - backup, rectangular type
19	413-520	2	BOLT - hex, 5/16 NC x 1-1/4 inch
20	193-29	2	WASHER, LOCK, Int Tooth, 5/16"
21	495-11034	2	WASHER, 5/16", SAE, flat
22	L113265	1	WIRE - alarm ground
23	192-20	1	WASHER, LOCK, 5/16"
24	425-105	2	NUT - hex, 5/16 inch NC
25	L113266	1	WIRE - harness to backup alarm
26	223-26	1	FUSE - 5 amperes, 3AG

4-80

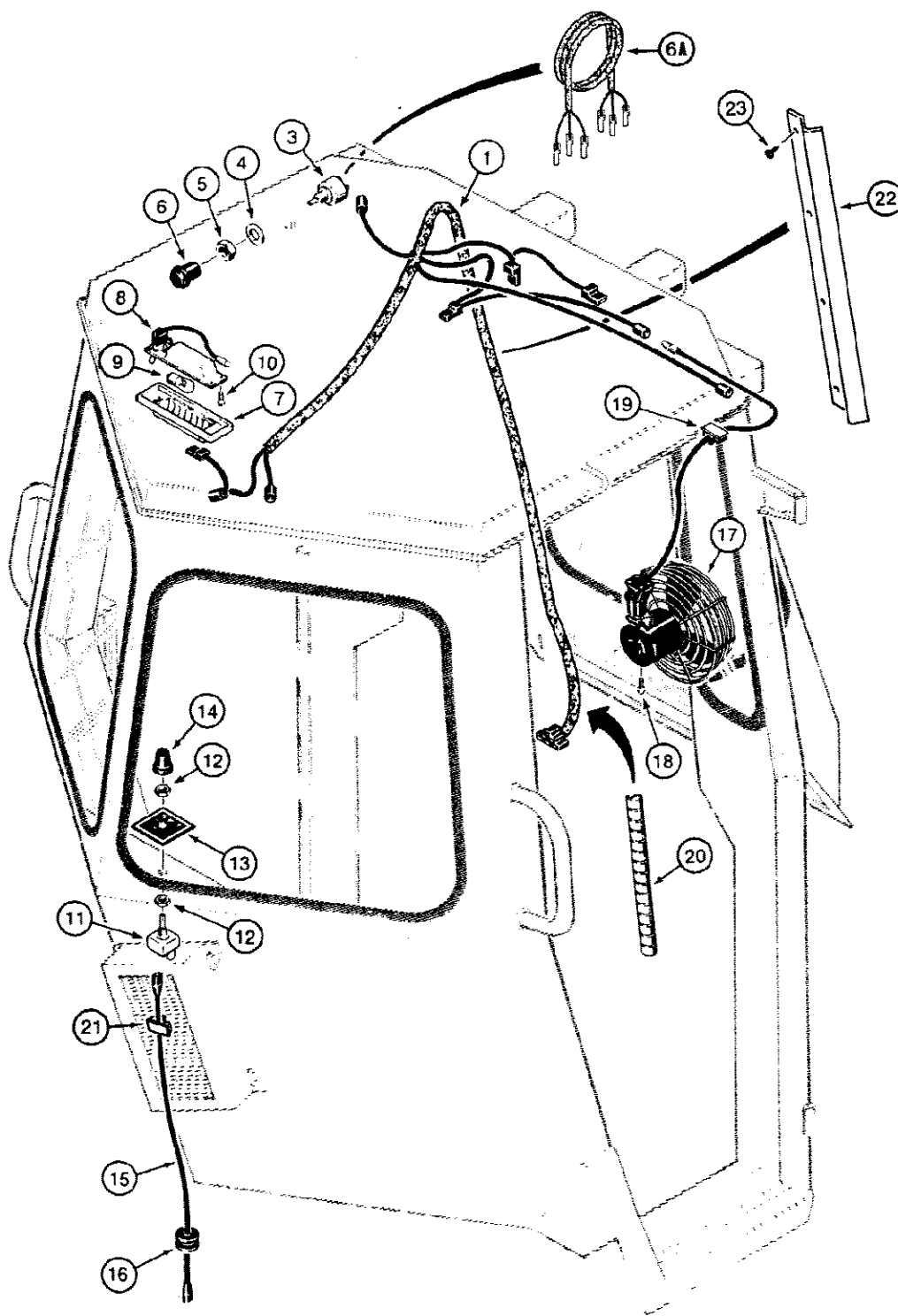

4-90

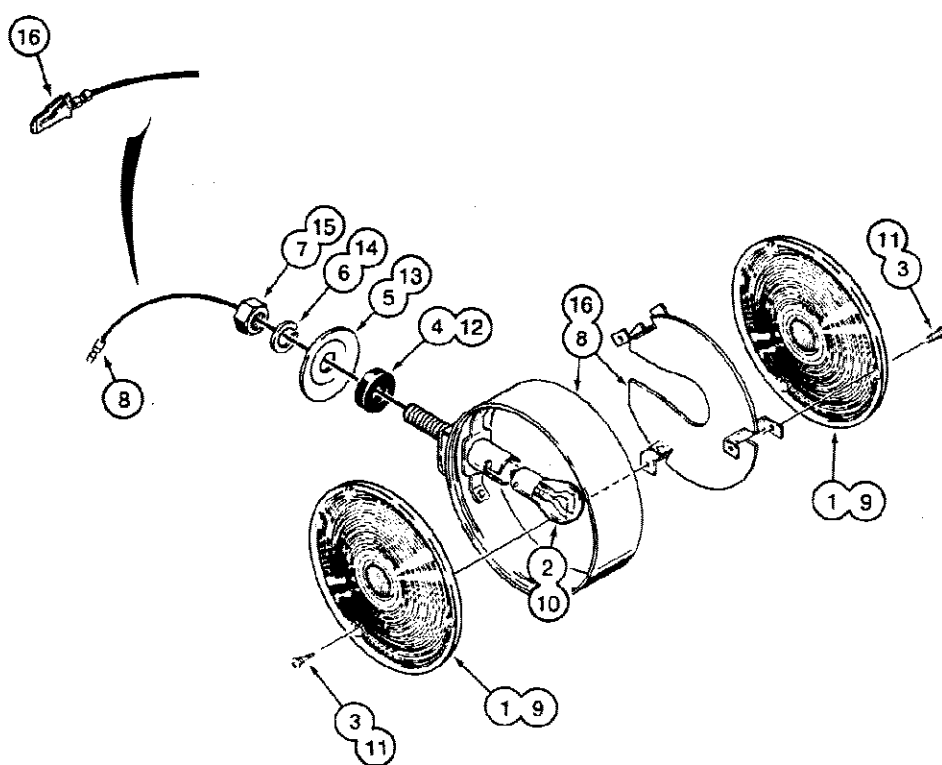

4-100

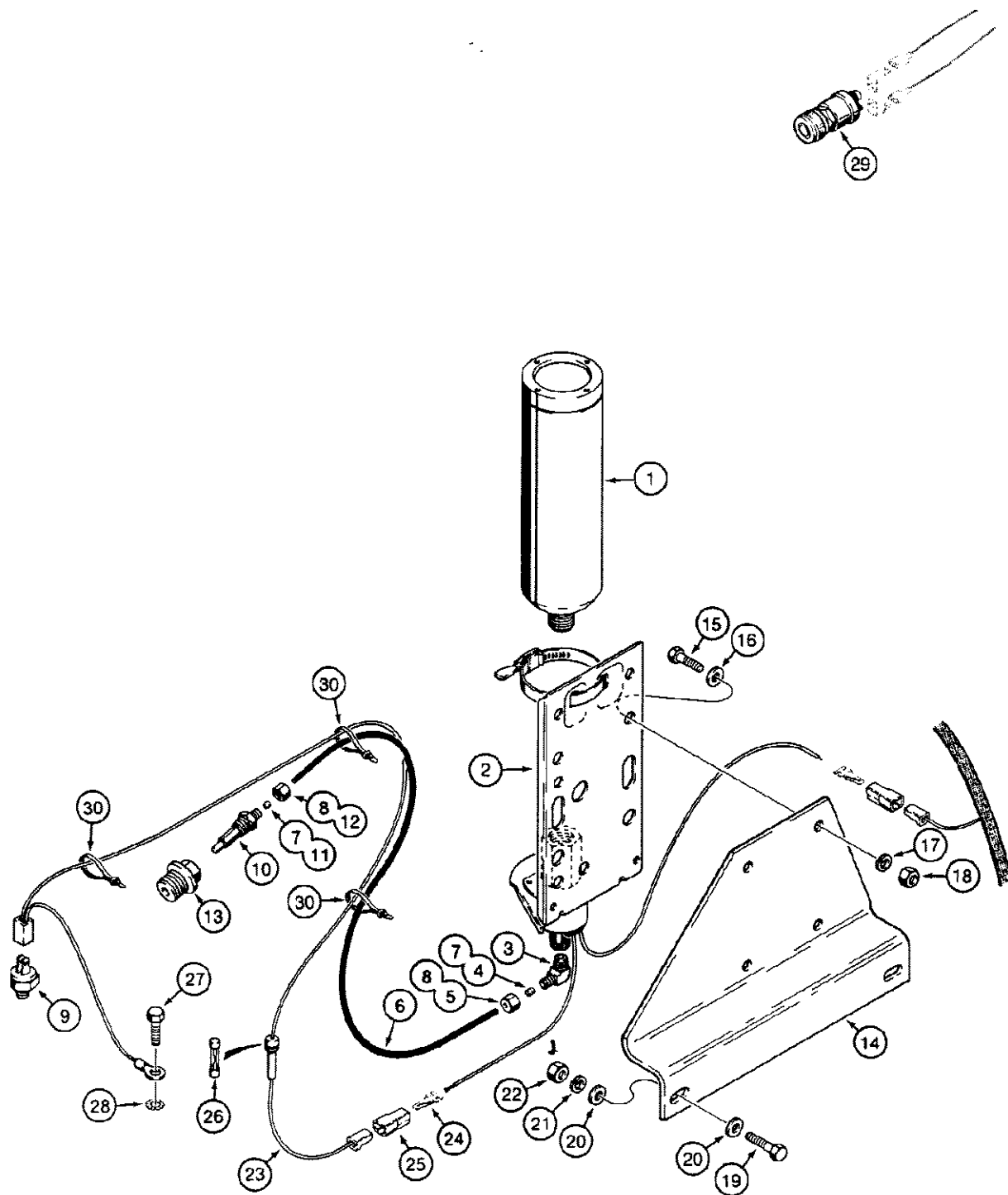

## W11B CASE UNIT LOADER - Steering

## 5-006 STEERING CONTROL VALVE WITH COLUMN

Ref	Part Number	Qty	Description
	L78473	1	CONTROL VALVE AND COLUMN ASSEMBLY - steering, Includes: Ref. 1 - 13
1	D82803	1	CONTROL VALVE ASSEMBLY - steering, parts list Figure 5-4
	S238868	1	COLUMN ASSEMBLY - steering, Includes: Ref. 2 - 13
2	NSS	1	COLUMN AND SHAFT - steering
3	N60346	1	WIRE AND TERMINAL - steering column
4	S63470	1	INSULATOR - plastic ring
5	S63469	1	RING - contact
6	S63454	1	INSULATOR - terminal
7	S63458	1	SPRING - insulator
8	S63467	1	RETAINER - spring
	S109356	1	KIT - insulator and brush, Includes: Ref. 9 and 10
9	NSS	1	GREASE PACKAGE - not shown
10	NSS	1	INSULATOR AND BRUSH - steering column
11	187-1116	2	SCREW - self-tapping, No. 10 - 24 NF x 1/4", plated
12	S115351	1	SEAL - cap
13	166-43	2	BOLT - Ferry head, 3/8" - 16 NC x 3/4", used for shipping purposes only, see Refs. 22-30 on Figure 5-3

## W11B CASE UNIT LOADER - Steering

## 5-016 L78437 AUXILIARY STEERING MOTOR

Ref	Part Number	Qty	Description
	L78437	1	MOTOR - auxiliary steering, Includes: Ref. 1 - 26
1	A47556	1	MOUNTING PLATE - drive end
	A47552	1	ARMATURE AND BEARING ASSEMBLY - motor, Includes: Ref. 2 and 3
2	NSS	1	BALL BEARING - end, plate, see note below, Order A47553 bearing package for service. Includes (1) sealed ball bearing and (1) spacer.
3	NSS	1	ARMATURE - motor
4	NSS	1	WASHER - thrust, terminal end
5	NSS	1	WASHER - plastic
6	A47562	1	BRUSH SET - Prestolite (1) ML-1012B and (2) ML-1034AS
	A25723	1	COIL ASSEMBLY - auxiliary steering motor, Includes: Ref. 7 and 8
7	NSS	1	FIELD - winding
8	NSS	4	SHOE - magnet
9	NSS	1	HOUSING - coil assembly
10	NSS	4	SCREW - pole, shoe
	A47557	1	TERMINAL KIT - motor, Includes: Ref. 11 - 17
11	NSS	1	STUD - terminal
12	NSS	1	WASHER - plain, inner
13	NSS	2	INSULATOR - round
14	NSS	1	INSULATOR - square
15	NSS	1	WASHER - plain, outer
16	NSS	2	WASHER - lock
17	NSS	2	NUT - hex
18	A47560	1	HEAD ASSEMBLY - commutator end, Includes: Ref. 19
19	A40275	1	SPRING SET - head
20	NSS	6	SCREW - mounting plate, drive end
21	NSS	6	WASHER - lock
22	A25654	2	SCREW - frame mounting
23	A47564	2	WASHER - lock
24	A47555	1	BAND - cover, Includes: Ref. 25 and 26
25	NSS	1	SCREW - band
26	NSS	1	NUT - square, band

CLICK HERE TO **DOWNLOAD** THE COMPLETE MANUAL

- Thank you very much for reading the preview of the manual.
- You can download the complete manual from: [www.heydownloads.com](http://www.heydownloads.com) by clicking the link below



- Please note: If there is no response to CLICKING the link, please download this PDF first and then click on it.

CLICK HERE TO **DOWNLOAD** THE COMPLETE MANUAL



## 6-016 TRANSMISSION MOUNTING, CLARK TRANSMISSION

Ref	Part Number	Qty	Description
1	REF	1	TRANSMISSION ASSEMBLY - parts list Figures 6-38 - 6-62
2	13-1228	8	BOLT, Hex, 3/4"-10 x 1 3/4", G5
3	192-27	8	WASHER, LOCK, 3/4"
	L118123	2	BRACKET ASSEMBLY - transmission mounting, Includes: Ref. 4 and 5
4	NSS	1	BRACKET - transmission mounting
5	A19066	1	MOUNT - transmission, rubber
6	13-1272	2	BOLT, Hex, 3/4"-10 x 4 1/2", G5
7	L79179	2	WASHER - flat, hardened
8	131-16	2	LOCKNUT, 3/4"-10, GB
9	A19068	4	WASHER - rubber transmission mount, 3-3/4" OD
10	L112126	2	STUD - housing to engine
11	892-1110	12	WASHER - lock, 10 mm
12	825-1110	2	NUT - hex, 10 mm - 1.5
13	814-10040	10	Bolt, Hex, M10 x 40, 8.8, Full Thd, Housing to engine
14	D47428	1	GASKET - converter housing to engine

Clark transmission numbers 9151556, 9151789, 9151760 and 9164337 and later.

## W11B CASE UNIT LOADER - Power Train

## 6-026 FUNK TRANSMISSION, FRONT HOUSING AND IDLER

Ref	Part Number	Qty	Description
1	N7866	1	HOUSING - front, transmission
2	221-841	1	PLUG - 1/4 inch PT
3	221-1847	1	PLUG - hex socket head, 1-1/4" NPT
4	D83197	1	PLUG - hex head, includes screen filter, not shown, Includes: Ref. 5
5	237-6016	1	O-RING - 1-11/16 x 1-13/32 x 1/8 inch
6	113-436	1	BOLT, Hex, 1/2"-13 x 5 1/2", G5
7	D83050	1	WASHER - sealing
8	D82973	1	SHAFT - idler gear
9	G10389	1	O-RING - shaft
10	D83017	1	BEARING - idler gear, double tapered roller assembly
11	D82975	1	IDLER GEAR - transmission
12	113-421	3	BOLT, Hex, 1/2"-13 x 2", G5
13	D82940	2	BUSHING - guides
14	425-108	2	NUT - hex, 1/2 inch NC
15	80087972	3	BOLT - hex, 1/2 NC x 2-1/2 inch
16	113-447	2	BOLT, Hex, 1/2"-13 x 3 1/2", G5
17	D82949	1	GASKET - housing
18	413-828	1	BOLT, Hex, 1/2"-13 x 1 3/4", G5
19	113-441	2	BOLT, Hex, 1/2"-13 x 2 1/4", G5

## W11B CASE UNIT LOADER - Power Train

## 6-036 FUNK TRANSMISSION, YOKE AND BRAKE

Ref	Part Number	Qty	Description
1	121-505	1	BOLT - hex head, 5/8" - 18 NF x 1-1/4", grade 8
2	D82994	1	RETAINER - yoke
3	A30916	1	O-RING - retainer
4	D82978	3	SHIM - retainer
5	D82980	1	YOKE - drive shaft connecting
6	D83039	1	DRUM - brake
7	492-11038	6	3/8"
8	129-123	6	NUT, 3/8"-24, G5
9	D47524	2	SHOE AND LINING - brake
10	S69560	2	SPRING - shoe
11	D83042	1	SPACER - lever
12	S69558	1	LEVER - bellcrank
13	S69557	1	PLATE - back side, 13 WILL ONLY BE AVAILABLE IN KIT # 100222A1. REF: 13A PER ECS # S9104-53, WHEN DEPLETED,
14	113-490	4	BOLT, Hex, 1/2"-13 x 7/8", G8, Full Thd

## 6-044 CLARK TRANSMISSION, LOW AND FORWARD CLUTCH ASSEMBLIES

Ref	Part Number	Qty	Description
	L117957	1	TRANSMISSION ASSEMBLY - forward and reverse, with reverse idler shaft bolted to converter housing, no longer available, order L126647 when replacing complete transmission, Includes: Ref. 1 - 16
	L126647	1	TRANSMISSION ASSEMBLY - forward and reverse, with reverse idler shaft pressed into converter housing, Includes: Ref. 1 - 16
	NSS	1	CLUTCH ASSEMBLY - low, Includes: Ref. 1 - 8
1	E114380	1	RETAINING RING - backing plate
2	E114381	1	GEAR - backing plate, clutch disc
3	N7219	8	DISC - clutch, friction, inner teeth
4	E114383	8	DISC - clutch, metal, outer teeth
5	E114384	1	PISTON - clutch
6	E114385	1	RING - piston, outer clutch
7	E114386	1	SEAL - piston, inner clutch
8	N7220	1	DRUM AND SHAFT - low clutch
	NSS	1	DRUM AND SHAFT ASSEMBLY - forward, Includes: Ref. 9 - 16
9	E114380	1	RETAINING RING - backing plate
10	E114381	1	GEAR - backing plate, clutch disc
11	N7217	8	DISC - clutch, friction, inner teeth
12	E114383	8	DISC - clutch, metal, outer teeth
13	D87250	1	PISTON - clutch
14	E114385	1	RING - piston, outer clutch
15	E114386	1	SEAL - piston, inner clutch
16	S117879	1	DRUM AND SHAFT - forward

This figure is for the Clark series 18000 transmission.

## W11B CASE UNIT LOADER - Power Train

## 6-054 CLARK TRANSMISSION, OUTPUT SHAFT, IDLER SHAFT, AND LOW GEARS

Ref	Part Number	Qty	Description
	L117957	1	TRANSMISSION ASSEMBLY - forward and reverse, with reverse idler shaft bolted to converter housing, no longer available, order L126647 when replacing complete transmission, Includes: Ref. 1 - 33B and Ref. 34 - 62 on Figure 6-56
	L126647	1	TRANSMISSION ASSEMBLY - forward and reverse, with reverse idler shaft pressed into converter housing, Includes: Ref. 1 - 33B and Ref. 34 - 62 on Figure 6-56
1	E114340	1	BEARING - front, low speed clutch shaft
2	E114341	1	SPACER - front bearing
3	S89657	1	BEARING - gear, low speed
4	S89658	1	RING - bearing retaining
5	N7213	1	SPACER - low speed gear
6	N13326	1	HUB - low gear, Includes: Ref. 6A
6A	N13129	1	RING - oil retaining, reverse clutch gear, not shown
7	S89658	1	RING - bearing retaining
8	S89657	1	BEARING - low speed gear
9	E114334	1	RETAINING RING - bearing
10	E114328	1	SNAP RING - spring retainer
11	E114332	1	RETAINER - spring
12	E114331	1	SPRING - piston return
13	NSS	1	CLUTCH ASSEMBLY - low, parts list Figure 6-44
14	N7276	1	BEARING - rear, low speed shaft
15	E114268	1	WASHER - rear bearing support
16	E114334	1	RETAINING RING - rear bearing
17	E114360	1	RING - bearing retaining
18	N8134	1	O-RING - rear bearing cap, large
19	A27891	1	O-RING - bearing cap, rear, small
20	N13147	1	HOUSING - rear bearing
21	218-5152	1	PLUG, Hex Hd, 3/8"-24 ORB, Includes Ref. 22
22	218-5002	1	O-Ring, 3-1, .301" ID x .064" Thk
23	192-22	4	WASHER, LOCK, 7/16"
24	425-117	4	NUT - hex, 7/16 inch NF
25	N7209	4	STUD - bearing cap
26	N8832	1	RETAINING RING - clutch disc hub
27	N13129	1	RING - oil retaining, reverse clutch gear, not shown
28	E114350	1	CARRIER - bearing
29	E114349	1	SNAP RING - bearing carrier
30	E114346	2	RING - bearing locating
31	E114347	1	BEARING - third clutch disc hub
32	E114345	1	RETAINING RING - bearing
33	A55775	1	SNAP RING - idler gear
33A	N14392	1	GEAR - idler shaft
33B	N14393	1	SHAFT - idler

## W11B CASE UNIT LOADER - Power Train

## 6-064 FRONT AXLE DRIVE SHAFT AND BEARING, FUNK TRANSMISSION WITH

Ref	Part Number	Qty	Description
	L77276	1	SHAFT, DRIVE - front, to axle, Includes: Ref. 1 - 4
	L36151	1	KIT, SPIDER AND BEARING ASSEMBLY - drive shaft, Includes: Ref. 1 - 3
1	NSS	1	NOT SERVICED SEPARATELY, SPIDER AND BEARING - drive shaft
2	A17298	8	BOLT, Spider
3	219-417	1	NIPPLE, LUBE, 1/4"-28 NPT x 1.62" lg,
4	D80542	1	TUBE, Drive shaft
5	132-338	1	PIN, SPLIT (COTTER), 1/8" x 2 1/2",
6	L33629	1	NUT, Hex slotted, special
7	D28266	1	WASHER, Special
8	L74590	1	FORK, YOKE - drive shaft
9	113-516	4	BOLT, Hex, 9/16"-12 x 1 3/4", G5,
10	192-24	4	WASHER, LOCK, 9/16",
11	129-106	4	NUT, 9/16"-12, G5,
	L106070	1	BEARING ASSY, SUPPORT ASSEMBLY - front drive shaft, uses set screws, Includes: Ref. 12 - 18
12	219-1	1	NIPPLE, LUBE, 1/8"-27 x .66 lg,
13	NSS	1	NOT SERVICED SEPARATELY, HOUSING - bearing, may have holes for set screws instead of slots
14	L33788	1	PIN, AXLE, Lock
	L33787	1	KIT, Repair, bearing and collar, converts from set screws to collar arrangement, Includes: Ref. 15 - 17
15	NSS	1	NOT SERVICED SEPARATELY, BEARING AND SEAL - center bearing
16	L33789	1	COLLAR, Bearing, if used
17	61-416	1	SCREW, Hex Soc Hd, 1/4"-20 x 1", If used
18	84-65	2	SET SCREW, Hex Soc, 3/8"-24 x 5/16",

NOTE: Original production bearings may have holes for set screws (item 18) instead of slots.

## W11B CASE UNIT LOADER

## 6-074 MIDDLE AND REAR DRIVE SHAFTS, CLARK TRANSMISSION WITH

Ref	Part Number	Qty	Description
	L123715	1	DRIVE SHAFT - middle, transmission to front axle drive shaft, Includes: Ref. 1 - 9, DRIVE SHAFT U-JOINTS CONTAIN (2) WINGS WITH TAPPED HOLES AND (2) WINGS WITH HOLES
1	NSS	1	YOKE AND TUBE - external spline
2	L31775	1	YOKE AND TUBE - internal spline
3	L32425	1	SEAL - dust
4	219-1	1	FITTING - grease, straight, 1/8 PT x 21/32 inch long
	N14752	2	KIT - U-joint repair, Includes: Ref. 5 - 9
5	28-632	4	BOLT - hex head, 3/8" - 24 NF x 2", grade 8
6	28-616	4	BOLT - hex, 3/8 NF x 1 inch, grade 8
7	192-61	8	3/8"
	N8198	1	KIT - U-joint, drive shaft, Includes: Ref. 8 and 9
8	219-1	1	FITTING - grease, straight, 1/8 PT x 21/32 inch long
9	NSS	1	U-JOINT, drive shaft
	L123713	1	DRIVE SHAFT - rear, transmission to rear axle, Includes: Ref. 10 - 18
10	N14750	1	YOKE AND TUBE - internal spline, rear drive shaft
11	N14751	1	YOKE AND TUBE - external spline, rear drive shaft
12	N8200	1	SEAL - dust, rear drive shaft
13	219-1	1	FITTING - grease, straight, 1/8 PT x 21/32 inch long, rear drive shaft
	N14747	2	KIT - U-joint repair, rear drive shaft, Includes: Ref. 14 - 18
14	28-632	4	BOLT - hex head, 3/8" - 24 NF x 2", grade 8, rear drive shaft
15	28-616	4	BOLT - hex, 3/8 NF x 1 inch, grade 8, rear drive shaft
16	192-61	8	3/8", rear drive shaft
17	219-1	1	FITTING - grease, straight, 1/8 PT x 21/32 inch long, rear drive shaft
18	NSS	1	U-JOINT, drive shaft, rear

6-84

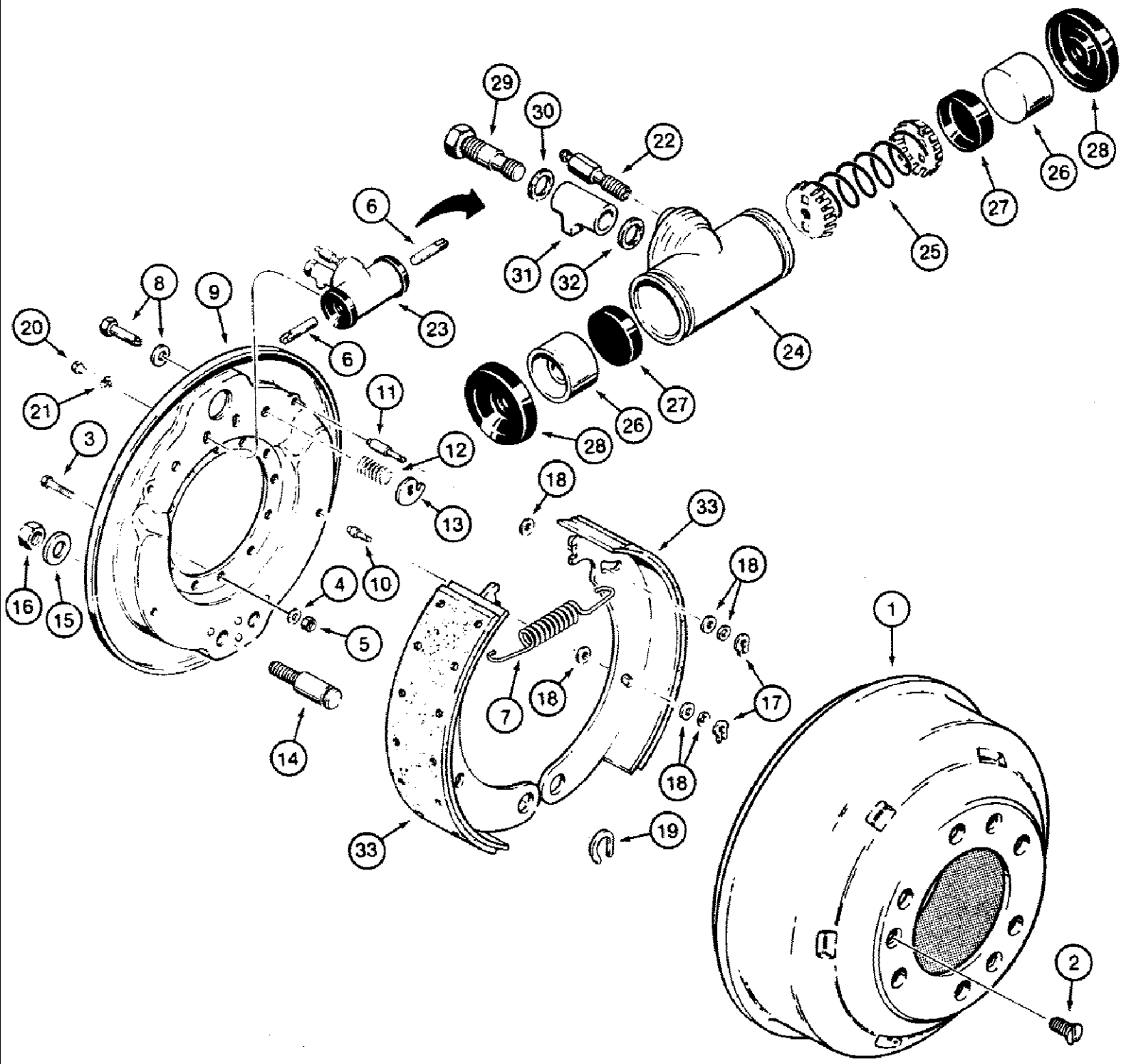

7-6

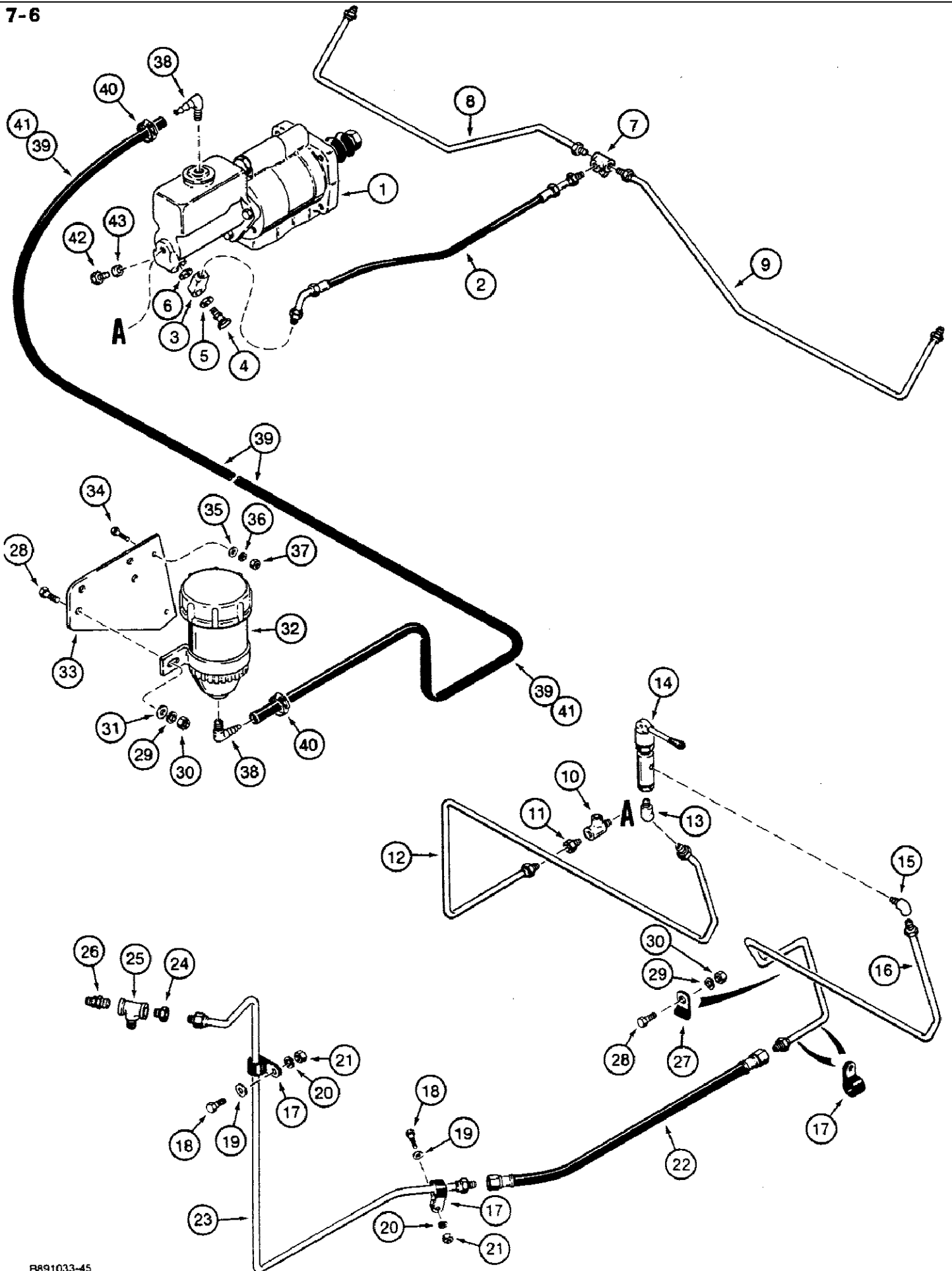

7-14

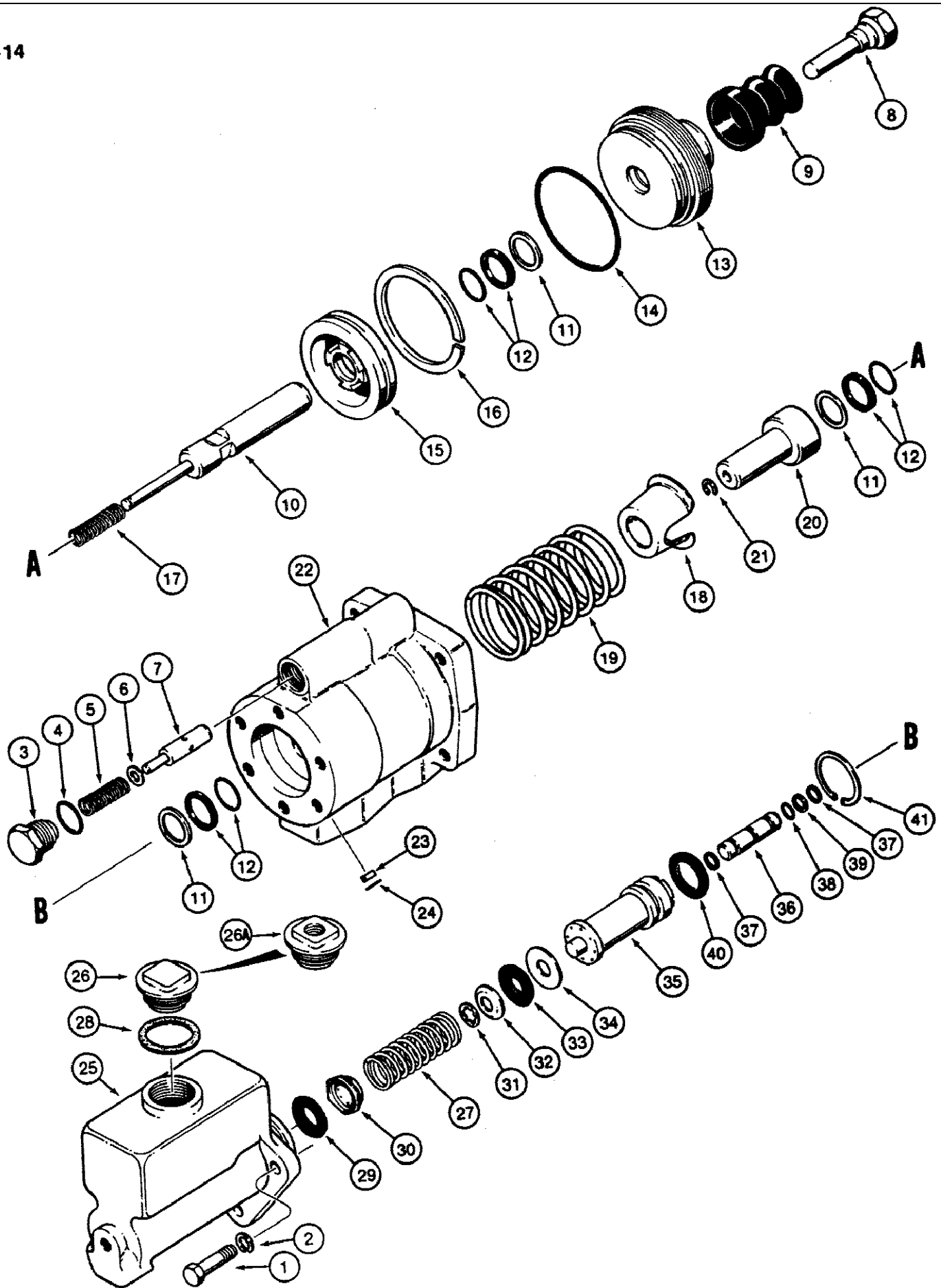



## W11B CASE UNIT LOADER - Hydraulics

## 8-010 HYDRAULIC CIRCUIT, RETURN LINES - VALVE TO FILTER FOR MODELS W/ CLARK TRANSMISSION

Ref	Part Number	Qty	Description
1	218-5072	1	ADAPTER - straight, models without auxiliary steering, Includes: Ref. 2, For auxiliary steering hydraulic circuit see Figures 5-10 and 5-12.
2	237-6020	1	O-RING, 20-1, 90 Duro, 1.475" ID x .118" Thk, Adapter
3	L73855	1	FILTER - hydraulic oil, Includes: Ref. 4 - 8
4	NSS	1	HEAD - filter
5	D74434	1	VALVE - bypass
6	D80540	1	SPRING - bypass valve
	D80538	1	KIT - filter element, Includes: Ref. 7 and 8
7	NSS	1	ELEMENT - filter
8	D80539	1	SEAL - element
9	218-5293	1	TEE - filter to reservoir, models with auxiliary steering, Includes: Ref. 10, For auxiliary steering hydraulic circuit see Figures 5-10 and 5-12.
10	237-6020	1	O-RING, 20-1, 90 Duro, 1.475" ID x .118" Thk, Tee
11	218-5086	1	ADAPTER - straight, Includes: Ref. 12
12	237-6020	1	O-RING, 20-1, 90 Duro, 1.475" ID x .118" Thk, Adapter
13	L118201		TUBE - return to filter, models without automatic auxiliary steering
13	L127011		TUBE - return to filter, models with automatic auxiliary steering
14	R13912		HOSE - return to filter, 1" (25 mm) ID x 5-1/4" (457 mm) long, cut from 32798 hose, see below
15	214-256	2	CLAMP - hose, 13/16 to 1-3/4 inch
16	L118177	2	BRACKET - tube mounting
17	413-620	4	BOLT - hex, 3/8 NC x 1-1/4 inch
18	495-21044	4	WASHER - flat, 7/16 x 1 x 5/64 inch
19	492-11038	4	3/8"
20	129-103	4	NUT, 3/8"-16, G5
21	L78947	3	U-BOLT - 5/16" - 18 NC x 1"
22	195-103	6	NUT - hex, 1/2 inch NC
23	131-651	6	NUT - hex, self-locking, 5/16" - 18 NC
24	L118199	1	TUBE - return
25	L79056		HOSE - return from valve, 1" (25 mm) ID x 21" (533 mm) long, cut from H169037 hose, see below
26	214-256	2	CLAMP - hose, 13/16 to 1-3/4 inch
	32798	1	HOSE - 1" (25 mm) ID x 6" (152 mm) long, not shown
	H169037	1	HOSE - 1" (25 mm) ID x 44" (1118 mm) long, not shown

## W11B CASE UNIT LOADER - Hydraulics

## 8-020 HYDRAULIC CIRCUIT, PUMP TO BRAKE ACTUATOR FOR MODELS WITH CLARK TRANSMISSION

Ref	Part Number	Qty	Description
1	218-5107	1	ELBOW ASSEMBLY - 90 degree adjustable, 7/8-14 inch thread <sup>A</sup> , Includes: Ref. 2
2	237-6008	1	O-RING, 8-1, 90 Duro, .644" ID x .087" Thk
3	L118204	1	TUBE - brakes and steering, REF: 3A REPLACED BY L128338 - PER #ECS-58920-36 OLD # MUST BE RETAINED FOR UNITS BUILT PRIOR TO THIS CHANGE.
4	217-1020	1	STREET ELBOW - 90 degree, 3/4" NPT
5	217-1092	1	CONNECTOR - straight
6	S206607	1	COUPLING - male, quick disconnect
7	D123387	1	CAP - dust
8	L78949	4	U-BOLT - 5/16" - 18 NC x 5/8"
9	195-521	2	WASHER - flat, 11/32 x 11/16 x 3/64 inch
10	231-1445	8	NUT - hex, self-locking, 5/16" - 18 NC, plated
11	L74997	1	HOSE - lower, 20" (508 mm) long
12	L78937	1	TUBE - lower, supply booster
13	REF	1	BRAKE ACTUATOR - see Figures 7-12 through 7-16 for correct actuator
14	218-5062	2	ADAPTER - straight, 7/8-14 inch flare x O-ring boss, Includes: Ref. 15
15	237-6010	1	O-RING, 10-1, 90 Duro, .755" ID x .097" Thk
16	L101244	1	HOSE - brake actuator to unloading valve, 22-1/2" (572 mm) long
17	R12102	1	CLAMP - hose
18	413-620	1	BOLT - hex, 3/8 NC x 1-1/4 inch
19	495-21044	1	WASHER - flat, 7/16 x 1 x 5/64 inch
20	492-11038	1	3/8"
21	129-103	1	NUT, 3/8"-16, G5
22	218-5066	2	ADAPTER - straight, 5/8 x 1/2 straight inch thread, Includes: Ref. 23
23	237-6010	1	O-RING, 10-1, 90 Duro, .755" ID x .097" Thk
24	L103844	1	UNLOADING VALVE - parts list Figure 8-34
25	L101149	1	TUBE - U-shape
26	L101107	1	HOSE ASSEMBLY - unloading valve bypass, 16-1/2" (419 mm) long

## W11B CASE UNIT LOADER - Hydraulics

## 8-030 L77150 HYDRAULIC PUMP, USED ON MODELS WITH FUNK TRANSMISSION

Ref	Part Number	Qty	Description
	L77150	1	PUMP ASSEMBLY - hydraulic, Includes: Ref. 1 - 24, L77150 IS A EATON (CHAR-LYNN) PUMP ASSEMBLY - HYD.
1	NSS	4	BOLT - Ferry head, 3/8" - 16 x 5-1/4", grade 8
2	166-190	4	BOLT - Ferry head, 3/8" - 16 NC x 5-1/2", grade 8
3	D80499	1	COVER - drive shaft end, includes bushings
4	A25139	1	SEAL - shaft, Part of seal kit, P/N N13536
5	D80505	1	DRIVE GEAR - loader/steering circuit
6	D80506	1	IDLER GEAR - loader/steering circuit
7	H273912	2	SEAL - diaphragm, Part of seal kit, P/N N13536
8	H335331	1	DIAPHRAGM - loader/steering circuit, Part of seal kit, P/N N13536
9	D80507	1	DIAPHRAGM - brake circuit, Part of seal kit, P/N N13536
10	H260927	2	GASKET - pump, Part of seal kit, P/N N13536
11	H260935	2	PROTECTOR - gasket, Part of seal kit, P/N N13536
12	A45358	2	PLATE - wear, Part of seal kit, P/N N13536
13	D52925	4	DOWEL PIN - carrier to covers
14	R25508	1	HOUSING - gear, loader/steering circuit
15	H756221	4	O-RING - body, Part of seal kit, P/N N13536
16	D80501	1	CARRIER - bushing, includes bushings
17	H210724	1	HOUSING - gear, brake circuit
18	H233478	2	GEAR - brake circuit
19	H226878	1	KEY - gear to shaft
20	D80500	1	COVER - port end, includes bushings
21	D31403	2	SPRING - check ball, Part of seal kit, P/N N13536
22	211-312	2	BALL - check, Part of seal kit, P/N N13536
	N13537	1	TUBE/A - hose, Includes: Ref. 23 and 24
23	NSS	1	TUBE - hose
24	237-6016	1	O-RING - 1-11/16 x 1-13/32 x 1/8 inch, Part of seal kit, P/N N13536
	N13536	1	KIT - seal, Includes: Ref. 4, 7, 8, 9, 10, 11, 12, 15, 21, 22, 24

## W11B CASE UNIT LOADER - Hydraulics

## 8-040 G101190 AND G101191 LOADER CLAM CYLINDERS

Ref	Part Number	Qty	Description
1	G101190	1	CYLINDER ASSEMBLY - 3" (76 mm) ID x 9" (229 mm) stroke, clam, right-hand, Includes: Ref. 2 - 23
1	G101191	1	CYLINDER ASSEMBLY - 3" (76 mm) ID x 9" (229 mm) stroke, clam, left-hand, Includes: Ref. 2 - 23
2	G32305	1	TUBE ASSEMBLY - right-hand cylinder, Includes: Ref. 3
2	G32304	1	TUBE ASSEMBLY - left-hand cylinder, Includes: Ref. 3
3	30634	2	BUSHING - tube
	G104240	1	GLAND ASSEMBLY - cylinder, replaces glands without nylon plug, Includes: Ref. 4 - 12
4	NSS	1	GLAND - cylinder
5	G102569	1	PLUG - nylon, thread locking, gland, if used
6	D95143	1	WIPER - piston rod, outer, The cylinder assembly part number is stamped on some cylinder glands or tubes., Part of seal kit, P/N G109460
7	NSS	1	RETAINING RING - bushing
8	G102425	1	BUSHING - center, Part of seal kit, P/N G109460, The cylinder assembly part number is stamped on some cylinder glands or tubes.
9	G107922	1	U-CUP SEAL - piston rod, wide, with O-ring, The cylinder assembly part number is stamped on some cylinder glands or tubes., Part of seal kit, P/N G109460
9	G100777	1	U-CUP SEAL - piston rod, service option - severe heat or cold
10	G109094	1	SEAL - piston rod, narrow, used in addition to Ref. 9 in some glands, Part of seal kit, P/N G109460, The cylinder assembly part number is stamped on some cylinder glands or tubes.
11	G32122	1	BACKUP RING - gland O-ring, The cylinder assembly part number is stamped on some cylinder glands or tubes., Part of seal kit, P/N G109460
12	A30095	1	O-RING - trunnion, 3 x 3-1/4 x 1/8 inch, Part of seal kit, P/N G109460, The cylinder assembly part number is stamped on some cylinder glands or tubes.
13	187-1524	1	SCREW - hex head, self-tapping, No. 8 NC x 3/8 inch, if used
14	G33800	1	ROD ASSEMBLY - piston, 1-3/4" (44 mm) diameter, Includes: Ref. 15
15	30634	2	BUSHING - piston rod
16	G100704	1	PISTON - cylinder
17	G100444	1	BACKUP RING - piston seal, The cylinder assembly part number is stamped on some cylinder glands or tubes., Part of seal kit, P/N G109460
18	G102288	1	SEAL - piston, Part of seal kit, P/N G109460, The cylinder assembly part number is stamped on some cylinder glands or tubes.
19	G100449	2	RING - wear, piston, The cylinder assembly part number is stamped on some cylinder glands or tubes. Part of seal kit, P/N G109460
20	G32303	1	WASHER - hardened
21	28-1640	1	BOLT - hex head, 1" - 14 NF x 2-1/2", grade 8
22	219-1	1	FITTING - grease, straight, 1/8 PT x 21/32 inch long
23	219-55	1	NIPPLE, LUBE, 90c, 1/8" NPT x .84" lg
	G109460	1	KIT - seal, Includes: Ref. 6, 8, 9, 10, 11, 12, 17, 18, 19, same as G102405 kit plus Ref. 10 above, The cylinder assembly part number is stamped on some cylinder glands or tubes.

## W11B CASE UNIT LOADER - Hydraulics

## 8-050 LOADER CONTROL VALVE, BUCKET SPOOL DETENT

Ref	Part Number	Qty	Description
	D80693	1	DETENT ASSEMBLY - bucket spool, Includes: Ref. 1 - 23
1	61-520	2	BOLT - hex socket head, 5/16" - 18 NC x 1-1/4"
2	192-20	2	WASHER, LOCK, 5/16"
3	N9063	1	COVER - detent
4	D80682	1	PLATE - retaining
5	D80681	1	PLUG - spool end
6	D24777	2	SEAT - spring
7	D80692	1	CENTERING SPRING - spool
8	D80685	1	SPACER - washer
9	D80687	1	SPACER - tube
10	D80688	1	COIL - magnetic detent
11	D80689	1	WASHER - magnetic detent
12	D80686	1	SPACER - sleeve
13	61-448	1	BOLT - hex socket head, 1/4" - 20 NC x 3"
14	D82711	1	SPACER - sleeve
15	D80683	1	PLUG - end
16	D80691	1	RING - retaining
17	A27577	1	O-RING - 1-1/4 ID x 1/8 inch
18	187-1709	4	SCREW - self-tapping, No. 4 - 40 NC x 3/8"
19	N7172	1	CONNECTOR - electrical receptacle
20	S16824	1	O-RING - connector
21	D83095	2	CONNECTOR - wire
22	N7173	2	PIN - connector
23	N6601	1	SPACER - inner

## W11B CASE UNIT LOADER - Hydraulics

8-060 RETURN-TO-DIG, P.I.N. 9158252 AND AFTER

Ref	Part Number	Qty	Description
1	L117005	2	CLAMP - return-to-dig switch
2	L116453	1	BAR - return-to-dig
3	L115393	1	HARNESS - return-to-dig, used on models P.I.N. 9158252 - 9158303
4	413-828	2	BOLT, Hex, 1/2"-13 x 1 3/4", G5
5	80679	2	Washer, Lock, 1/2"
6	425-108	2	NUT - hex, 1/2 inch NC
7	R24718	2	WASHER - flat, hardened, 1/2"
8	L116441	1	LINK - dump assembly, Includes: Ref. 9
9	D33127	2	BUSHING - dump assembly link
10	R47120	1	SWITCH - return-to-dig
11	113-15	2	BOLT - hex, 1/4 NC x 2-1/4 inch
12	195-102	4	WASHER - flat, 5/16 x 3/4 x 1/16 inch
13	192-19	2	WASHER, LOCK, 1/4"
14	131-2	2	NUT - hex, self-locking, 1/4" - 20 NC
15	L115549	1	CLAMP - hose
16	L116439	1	BRACKET - switch mounting

NOTE: For replacement of return-to-dig harness P.I.N. 9158304 and after see pages 4-43 through 4-51 for electrical harnesses.

## W11B CASE UNIT LOADER - Chassis/Attachments

## 9-004 LOADER LIFT COMPONENTS

Ref	Part Number	Qty	Description
40	D25279	4	SNAP RING - pin retaining
41	A12089		UAR SPACER - washer
42	L100090	1	INDICATOR - bucket, if used
43	L74098	2	PIN - threaded
44	131-53	2	NUT - hex, self-locking, 1-1/2" - 12 NF, plated
45	L79709	1	LINK - right-hand, guide
46	L79710	1	LINK - left-hand, guide, Includes: Ref. 47
47	D33127	2	BUSHING, L79709 and L79710 link
48	L100089	3-4	LINK - bucket, Includes: Ref. 49
49	D33127	2	BUSHING
50	219-1	16	FITTING - grease, straight, 1/8 PT x 21/32 inch long
51	L77845	1	GUARD - right-hand, lift cylinder
52	L77846	1	GUARD - left-hand, lift cylinder
53	113-716	4	BOLT, Hex, 3/4"-10 x 3", G5
54	L79179	8	WASHER - flat, hardened
55	129-108	4	NUT, 3/4"-10, G5

9-014 RADIATOR SHROUD, GRILLE, AND HOOD

9-14

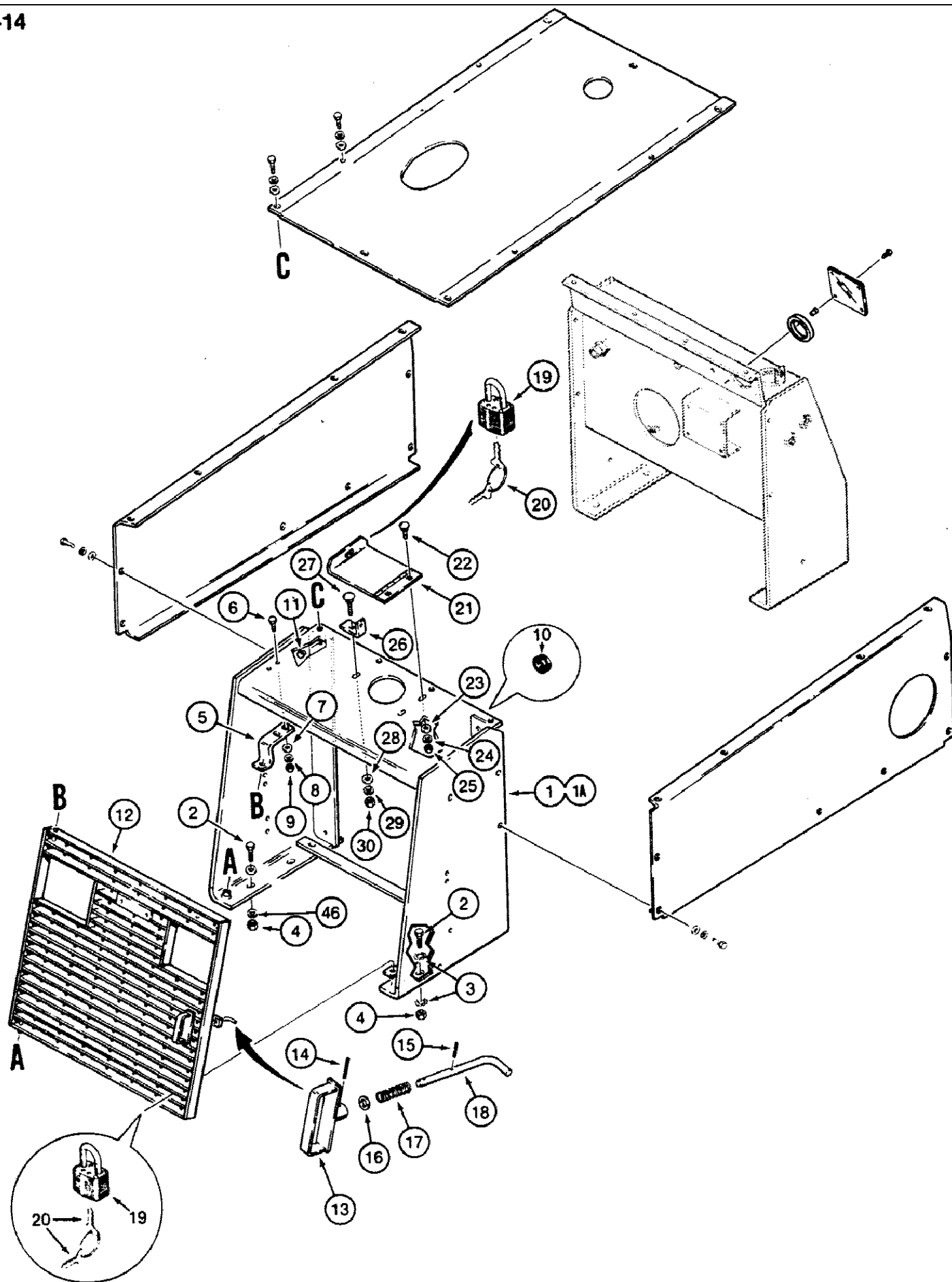

9-24

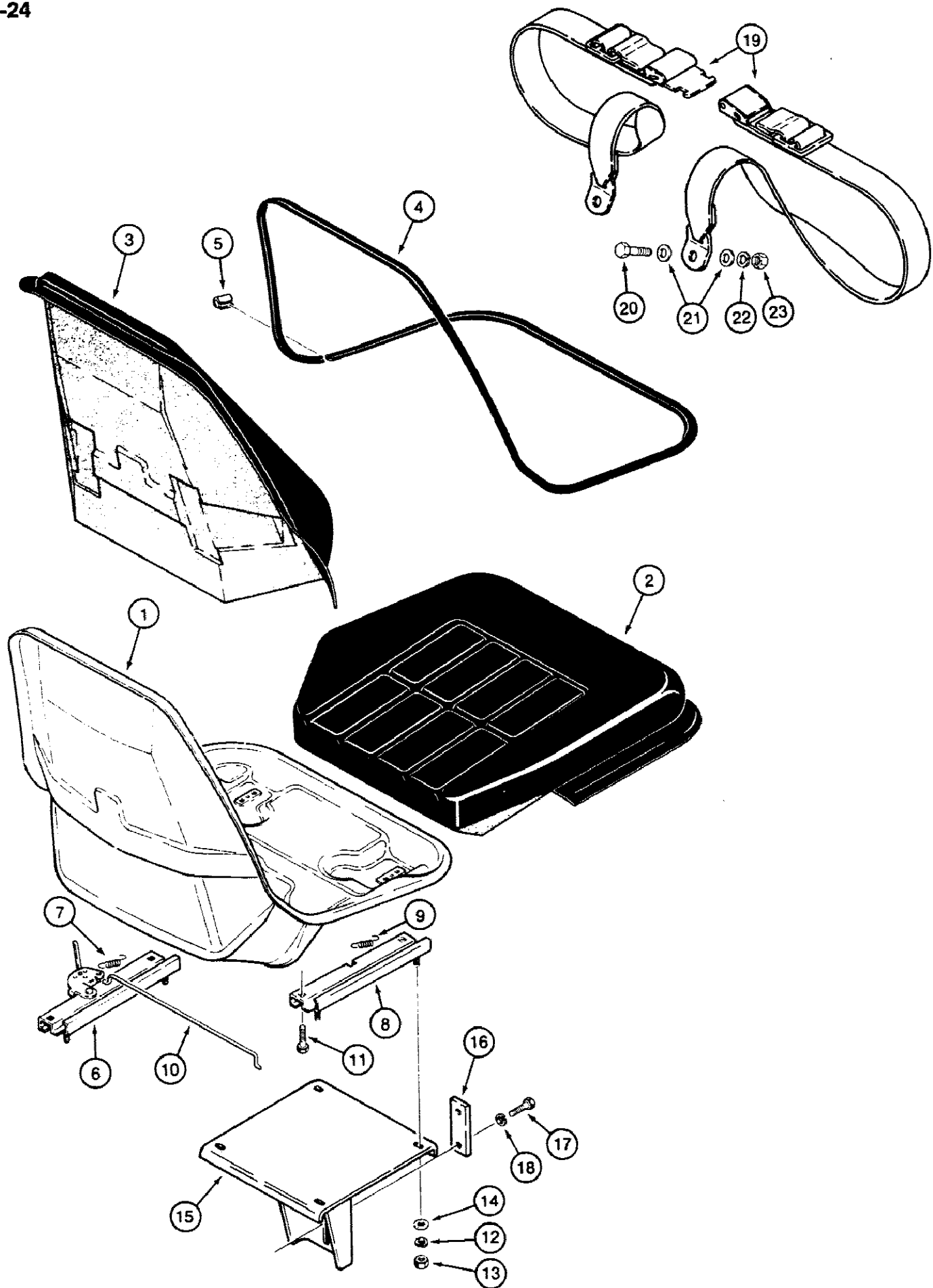

9-34

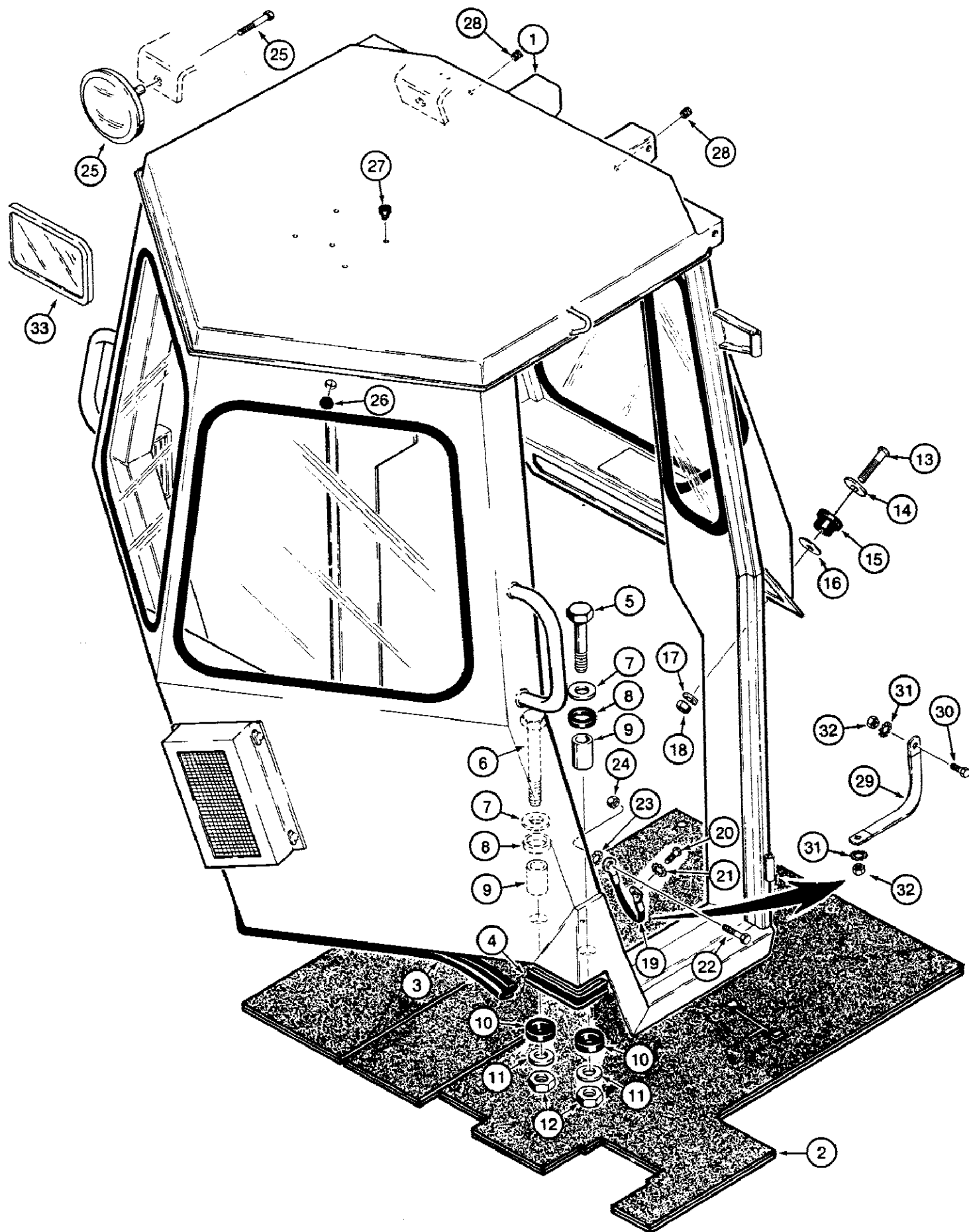

9-41A

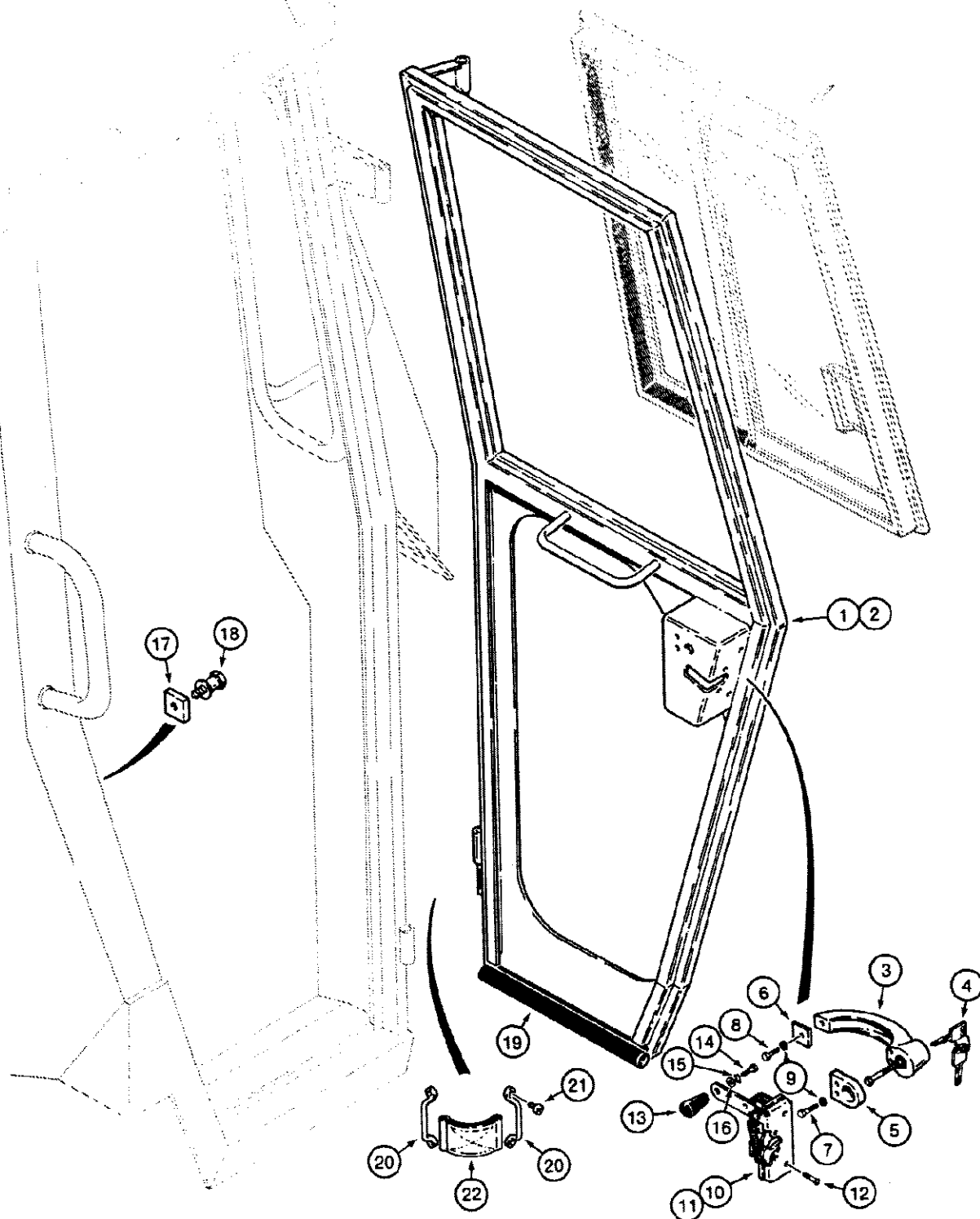

8891536-45

9-48

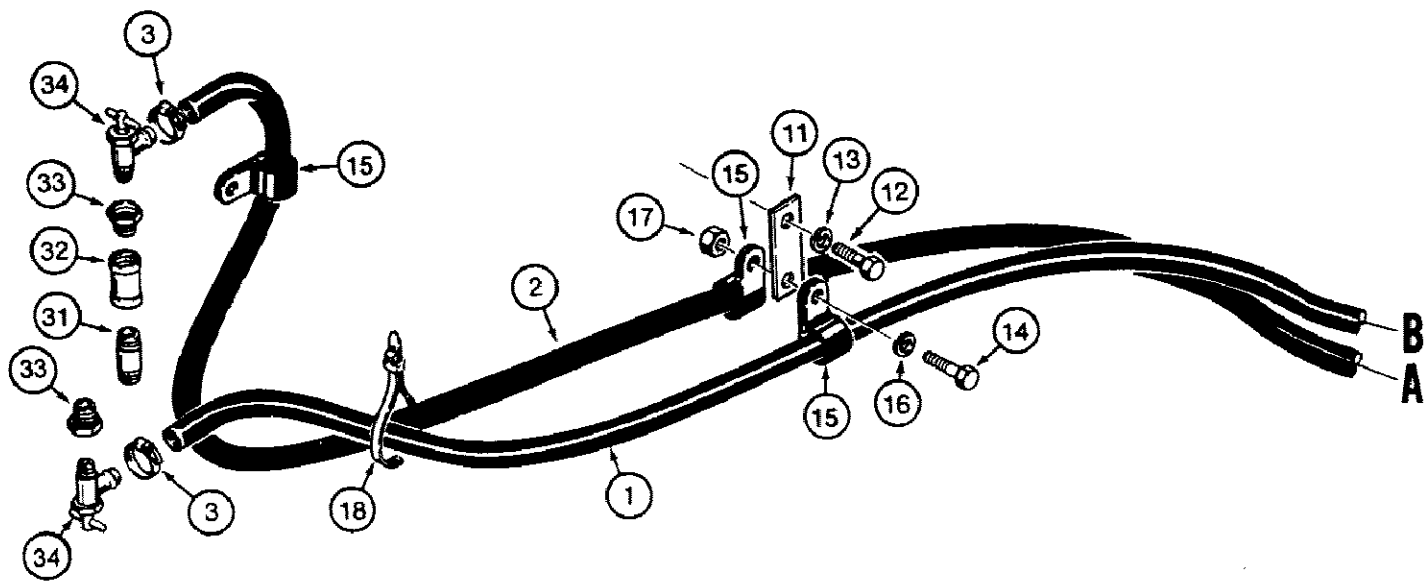
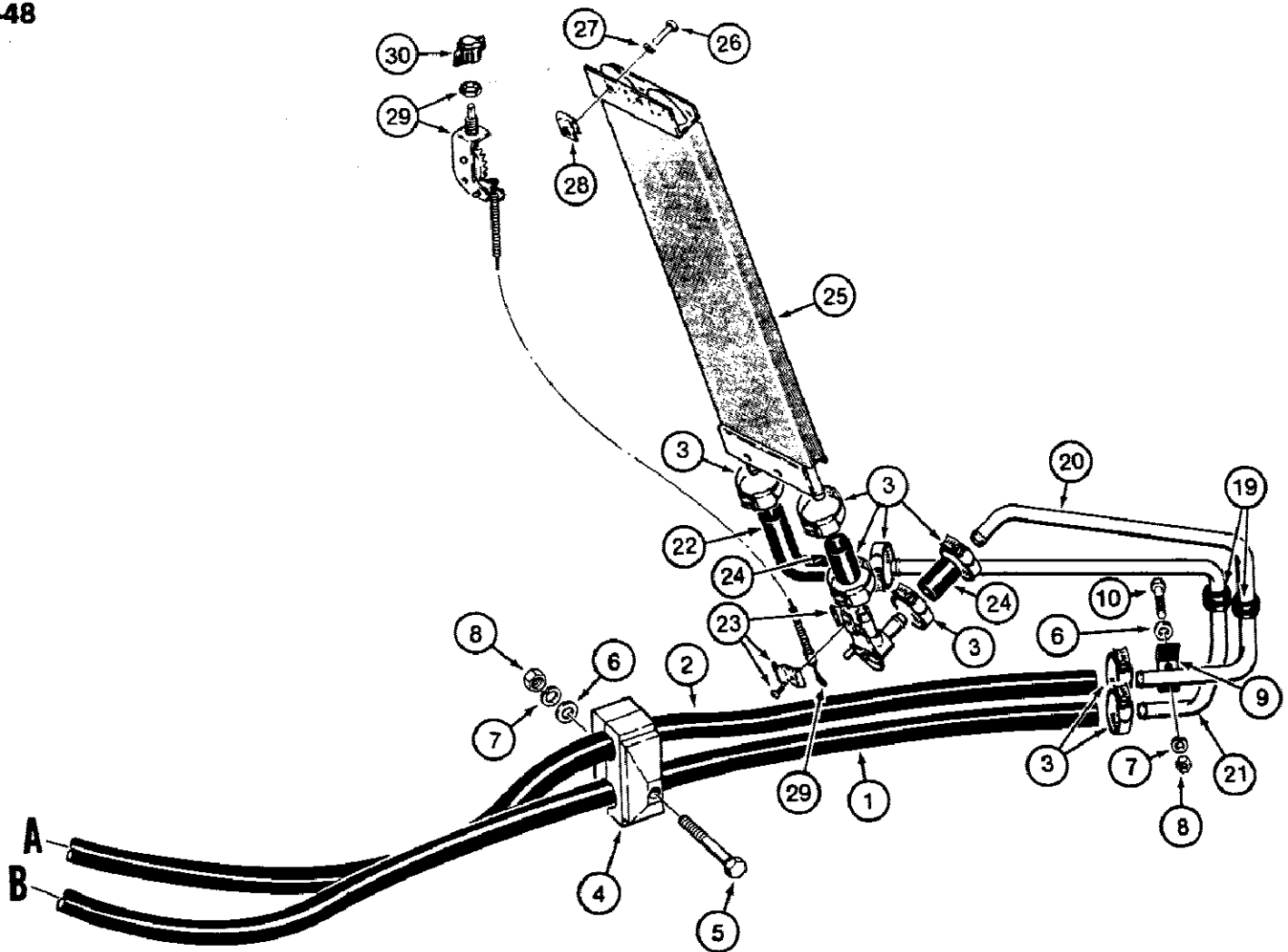

CLICK HERE TO **DOWNLOAD** THE COMPLETE MANUAL

- Thank you very much for reading the preview of the manual.
- You can download the complete manual from: [www.heydownloads.com](http://www.heydownloads.com) by clicking the link below



- Please note: If there is no response to CLICKING the link, please download this PDF first and then click on it.

CLICK HERE TO **DOWNLOAD** THE COMPLETE MANUAL