

Operator's Manual

EX135UR

Excavator

CLICK HERE TO **DOWNLOAD** THE COMPLETE MANUAL

- Thank you very much for reading the preview of the manual.
- You can download the complete manual from: www.heydownloads.com by clicking the link below



- Please note: If there is no response to CLICKING the link, please download this PDF first and then click on it.

CLICK HERE TO **DOWNLOAD** THE COMPLETE MANUAL

SAFETY

RECOGNIZE SAFETY INFORMATION

- This is the **SAFETY ALERT SYMBOL**.
 - When you see this symbol on your machine or in this manual, be alert to the potential for personal injury.
 - Follow recommended precautions and safe operating practices.



001-E01A-0001-2

SA-001

UNDERSTAND SIGNAL WORDS

- On machine safety signs, signal words designating the degree or level of hazard – **DANGER**, **WARNING**, or **CAUTION** – are used with the safety alert symbol.
 - **DANGER** indicates an imminently hazardous situation which, if not avoided, will result in death or serious injury.
 - **WARNING** indicates a potentially hazardous situation which, if not avoided, could result in death or serious injury.
 - **CAUTION** indicates a potentially hazardous situation which, if not avoided, may result in minor or moderate injury.
 - **DANGER** or **WARNING** safety signs are located near specific hazards. General precautions are listed on **CAUTION** safety signs.
- **CAUTION** also calls attention to safety messages in this manual.
- To avoid confusing machine protection with personal safety messages, a signal word **IMPORTANT** indicates a situation which, if not avoided, could result in damage to the machine.
- **NOTE** indicates an additional explanation for an element of information.



SA-461

002-E01A-0461-6

SAFETY

AVOID INJURY FROM BACK-OVER AND SWING ACCIDENTS

- If any person is present near the machine when backing or swinging the upperstructure, the machine may hit or run over that person, resulting in serious injury or death.

To avoid back-over and swing accidents:

- Always look around **BEFORE YOU BACK UP AND SWING THE MACHINE**. BE SURE THAT ALL BYSTANDERS ARE CLEAR.

- Keep the travel alarm in working condition (if equipped).

ALWAYS BE ALERT FOR BYSTANDERS MOVING INTO THE WORK AREA. USE THE HORN OR OTHER SIGNAL TO WARN BYSTANDERS BEFORE MOVING MACHINE.

- USE A SIGNAL PERSON WHEN BACKING UP IF YOUR VIEW IS OBSTRUCTED. ALWAYS KEEP THE SIGNAL PERSON IN VIEW.

Use hand signals, which conform to your local regulations, when work conditions require a signal person.

- No machine motions shall be made unless signals are clearly understood by both signalman and operator.
- Learn the meanings of all flags, signs, and markings used on the job and confirm who has the responsibility for signaling.
- Keep windows, mirrors, and lights clean and in good condition.
- Dust, heavy rain, fog, etc., can reduce visibility. As visibility decreases, reduce speed and use proper lighting.
- Read and understand all operating instructions in this operator's manual.

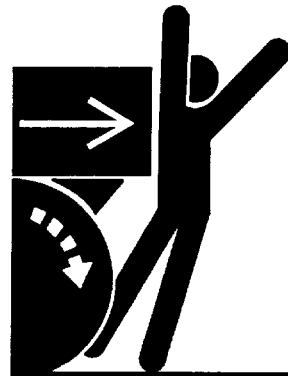

SA-383

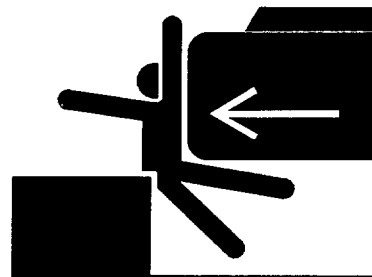

SA-384

SAFETY

PREVENT BURNS

Hot spraying fluids:

- After operation, engine coolant is hot and under pressure. Hot water or steam is contained in the engine, radiator and heater lines. Skin contact with escaping hot water or steam can cause severe burns.
 - To avoid possible injury from hot spraying water. DO NOT remove the radiator cap until the engine is cool. When opening, turn the cap slowly to the stop. Allow all pressure to be released before removing the cap.
 - The hydraulic oil tank is pressurized. Again, be sure to release all pressure before removing the cap.

Hot fluids and surfaces:

- Engine oil, gear oil and hydraulic oil also become hot during operation. The engine, hoses, lines and other parts become hot as well.
 - Wait for the oil and components to cool before starting any maintenance or inspection work.

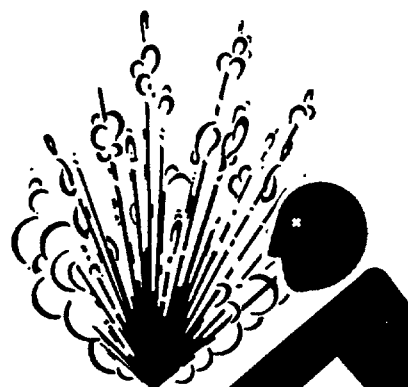

SA-039



SA-225

505-E01B-0498-5

REPLACE RUBBER HOSES PERIODICALLY

- Rubber hoses that contain flammable fluids under pressure may break due to aging, fatigue, and abrasion. It is very difficult to gauge the extent of deterioration due to aging, fatigue, and abrasion of rubber hoses by inspection alone.
 - Periodically replace the rubber hoses.
- Failure to periodically replace rubber hoses may cause a fire, fluid injection into skin, or the front attachment to fall on a person nearby, which may result in severe burns, gangrene, or otherwise serious injury or death.



SA-019

506-E01A-0019-3

SAFETY SIGNS

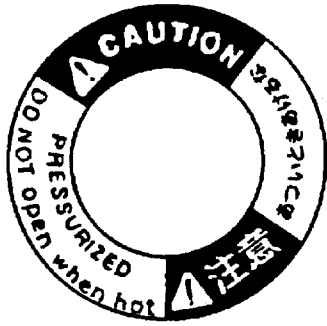

SS-407

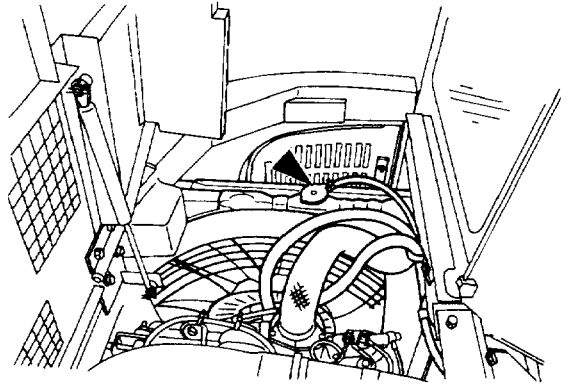

SS-892

OPERATOR'S STATION

WORK LIGHT SWITCH

Push work light switch ① to turn on work lights ② on the base machine and the instrument panel illumination.

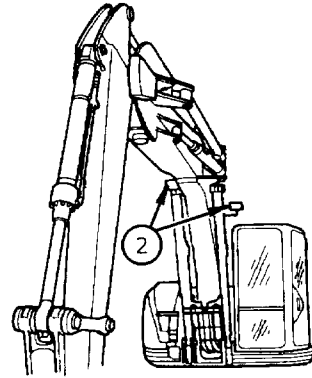

M191-01-010

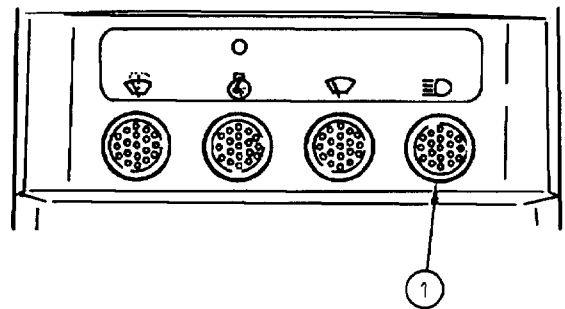

M190-01-007

CAB LIGHT

Move switch ① to turn the inside cab light on or off.

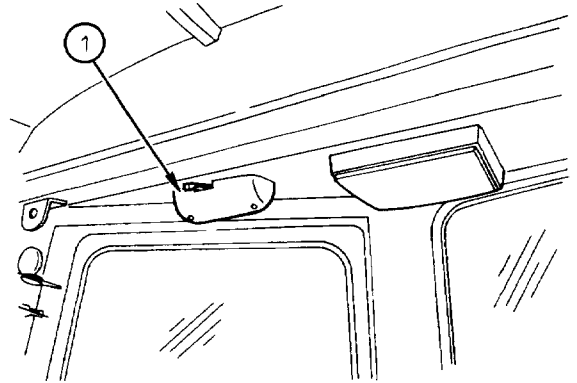

M191-01-011

OPERATOR'S STATION

- b. The automatic search function is activated by depressing and holding the tuning switch for more than one-half second. Automatic search changes from one frequency to the next strongest frequency.

In both cases, the frequency automatically appears on digital display ⑥; five seconds after tuning control switch ③ is no longer depressed frequency display ⑥ is replaced by the digital clock display.

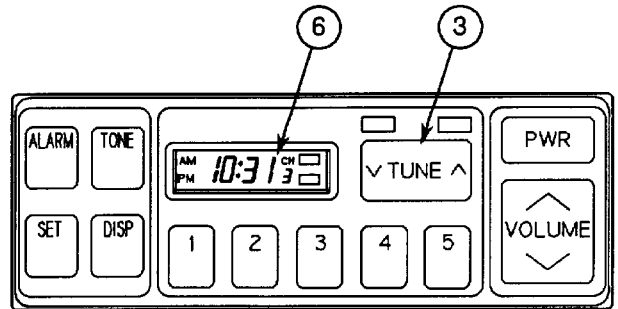

M104-01-025

3. Setting Tuning Buttons

IMPORTANT: Tuning buttons and clock will need to be reset any time the machine batteries are disconnected.

- Turn radio power switch ① ON.
- Use tuning control switch ③ to set radio to desired frequency.
- Depress and hold one of preset tuning buttons ④ for more than two seconds to set desired frequency. After the desired frequency has been set display ⑥ will show correct radio frequency. Release button.
- Repeat procedure to set remaining buttons or to reset a button to a different frequency.

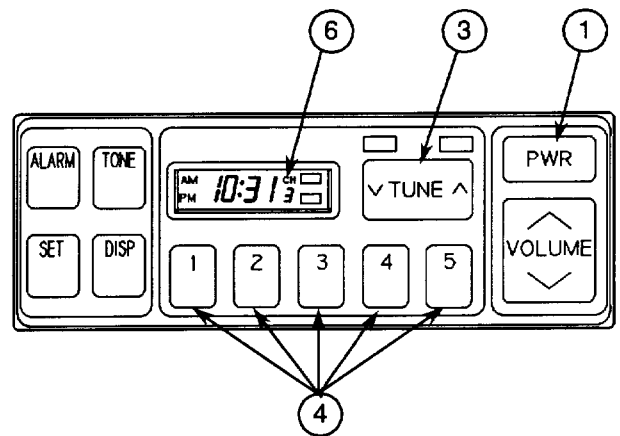

M104-01-025

NOTE: Setting tuning buttons allows the operator to quickly select desired frequency.

OPERATOR'S STATION

SEAT BELT

CAUTION: Be sure to always use the seat belt when operating the machine.

Before operating the machine, be sure to examine seat belt ①, buckle ②, and attaching hardware. Replace seat belt ①, buckle ②, or attaching hardware if they are damaged or worn.

Replace seat belt ① every three years, regardless of appearance.

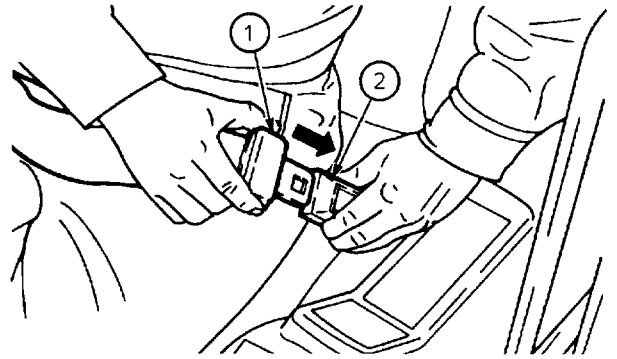

M107-01-044

Seat Belt

1. Confirm that seat belt ① is not twisted. Securely insert the end of seat belt ① into buckle ②. Lightly pull on the belt to confirm that the buckle latches securely.
2. Adjust seat belt ① so that the belt is snug but comfortable.
3. Push button ③ on buckle ② to unfasten seat belt ①.

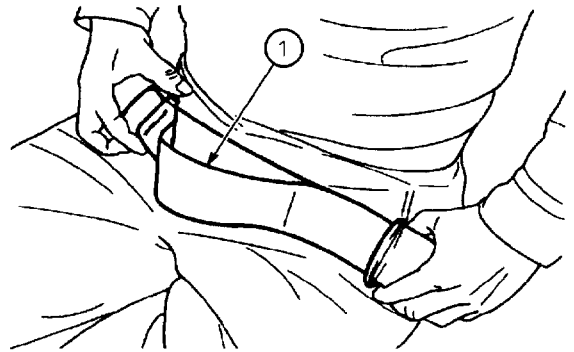

M107-01-045

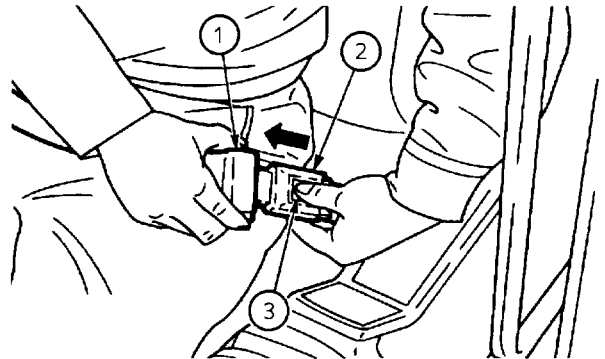

M107-01-046

OPERATING THE ENGINE

STOPPING THE ENGINE

1. ENGINE STOP PROCEDURE

- (1) Park the machine on a level surface.
- (2) Lower the bucket and blade to the ground.
- (3) Move engine speed control lever ① to the slow idle position and run the engine for 5 minutes to cool the engine.

IMPORTANT: Turbocharger may be damaged if the engine is not properly shut down.

- (4) Turn key switch ② OFF. Remove the key from the key switch.
- (5) Pull pilot control shut-off lever ③ to the LOCK position.

2. IF THE ENGINE DOES NOT STOP WITH THE KEY SWITCH TURNED IN OFF POSITION

If the engine does not stop when the key switch is turned to the OFF position (due to a machine or key switch malfunction), pull engine stop knob ④ all the way to the stop. The engine will stop.

NOTE: If the knob is pulled halfway, the engine may not start or may stall during operation. Be sure to push the knob to the fully retracted position before restarting the engine.

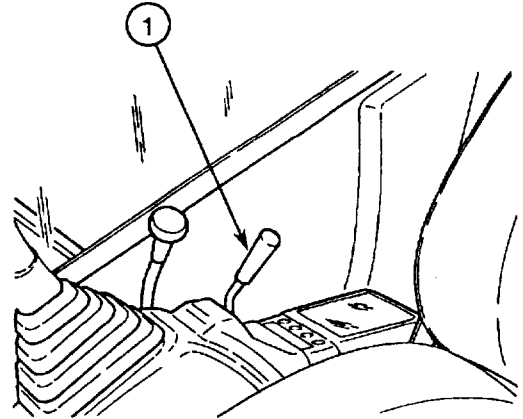

M191-03-004

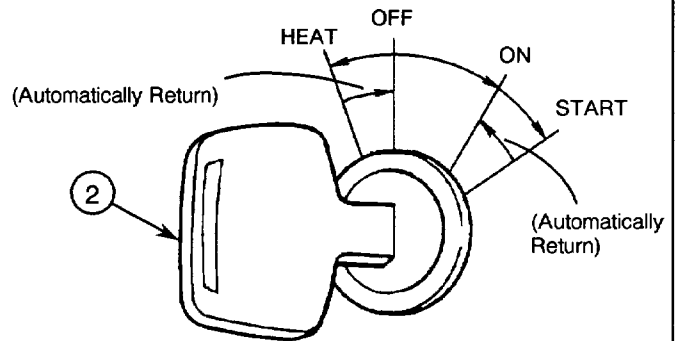

M191-01-036

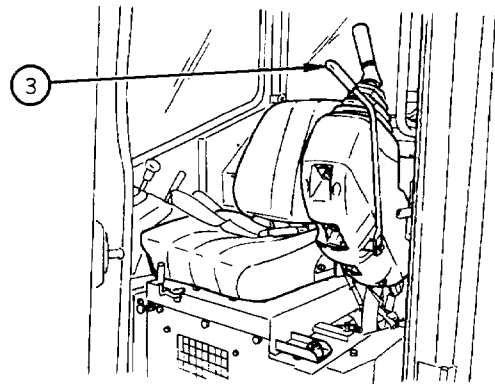

M191-03-009

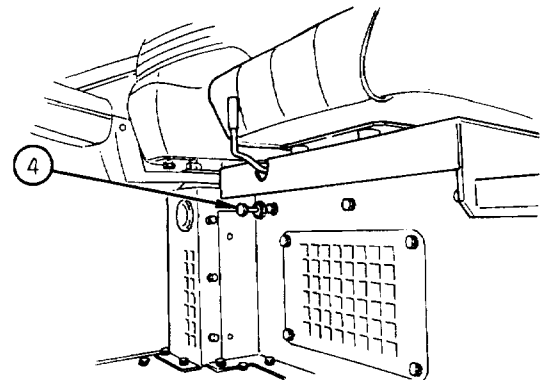

M191-03-005

OPERATING THE MACHINE

OFFSET PEDAL AND OFFSET SWITCH

The offset mechanism is convenient for ditching along road sides or walls.



CAUTION:

1. Before operating, always confirm that the bucket/cab collision prevention system is functioning properly. (See "Check the Bucket/Cab Collision Prevention System".)
2. This system is designed to prevent the bucket from damaging the operator's cab. However, do not rely on this system. Keep the bucket at least 300 to 400 mm (11.8 to 15.7 in) away from the cab.
3. Never try to raise a track off the ground with the front in the offset position. This will cause the machine to become unstable and possibly tip over.
4. If the front attachment is replaced, the collision prevention system must be readjusted. When replacing the front attachment, be sure to consult your authorized dealer.
5. Offset switch ① functions only when auto-MARCCINO switch ② is ON. Operate offset pedal when auto-MARCCINO switch ② is OFF. When auto-MARCCINO switch ② is ON, both offset switch ① and offset pedal ③ are operable. Use whichever you like.
6. Offset switch ① reduces the maximum speed slower than the offset pedal to improve controllability.

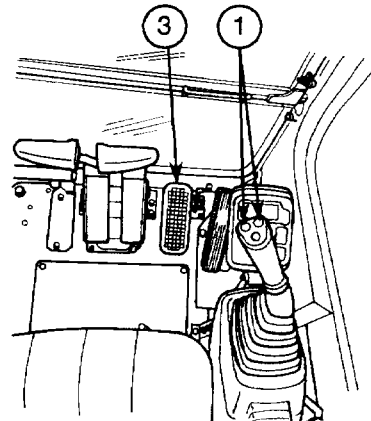

M191-01-028

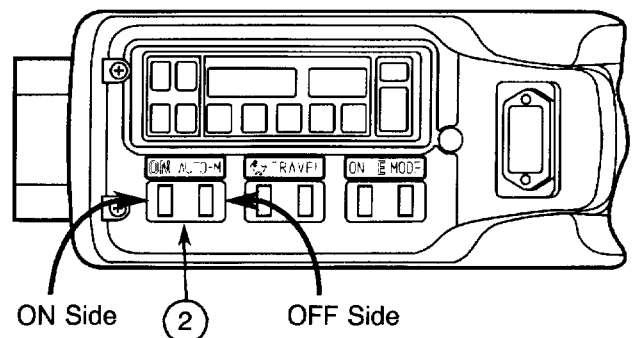

M191-01-051

CLICK HERE TO **DOWNLOAD** THE COMPLETE MANUAL

- Thank you very much for reading the preview of the manual.
- You can download the complete manual from: www.heydownloads.com by clicking the link below



- Please note: If there is no response to CLICKING the link, please download this PDF first and then click on it.

CLICK HERE TO **DOWNLOAD** THE COMPLETE MANUAL

OPERATING THE MACHINE

3. Front Movement Restriction After Automatic Stops

When the front-end attachment automatically stops with the bucket in range ②, shown in the illustration, the boom raise, arm roll-in, and left offset functions cannot be operated. Move the bucket forward or offset the arm to the right to restore the normal front operation.

When the front-end attachment automatically stops with the bucket in range ③, shown in the illustration, only the left offset function cannot be operated.

NOTE: *The boom raise and arm roll-in functions may not be restored when the bucket is moved forward or the arm is offset to the right only by a distance of 50 to 100 mm (2.0 to 3.9 in). This is not a system failure. Simply move the bucket forward further or offset the arm further to the right to restore normal front operation.*

Slight discrepancies of the automatic stop position will be caused by the ambient temperature. This is not a system failure.

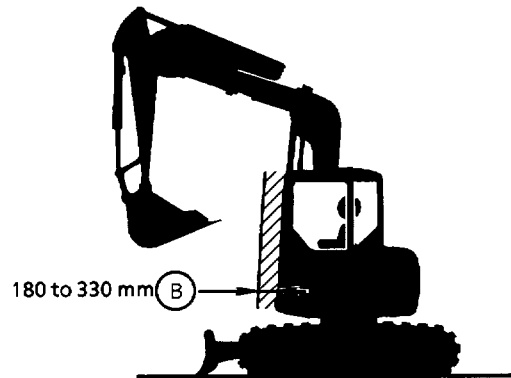

M190-05-017

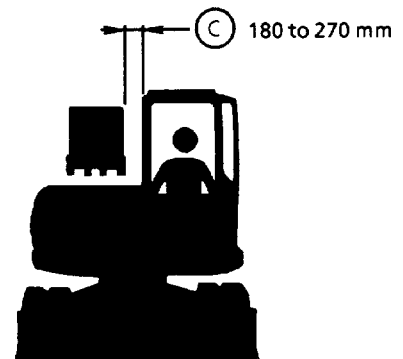

M190-05-016

OPERATING THE MACHINE

EMERGENCY REDUNDANT SWITCH

Use this emergency redundant switch ① only when the front-end attachment stops and cannot be operated because of a failure in the system even if the emergency deactivation switch is turned ON. Continuous pressing of switch ① will allow the machine to be moved to a safer area.

CAUTION: Never operate the machine with emergency redundant switch ① turned ON. If this switch is turned ON, the bucket/cab collision prevention system is deactivated and the front-end attachment may hit the cab. Take care to avoid hitting the cab with the front-end attachment while moving the machine to a safer area.

When emergency redundant switch ① is:

ON : The automatic stop function will be deactivated. A long electronic beep sounds continuously.

OFF: The bucket/cab collision prevention system function is restored; the machine can be operated normally.

On releasing your finger, the switch will automatically return to the OFF position.

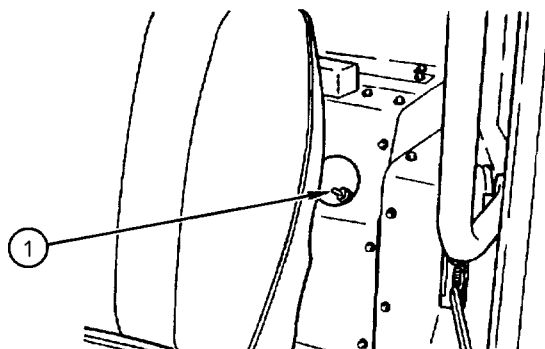

M190-05-020

EMERGENCY STOP

If any failure occurs in the bucket-cab collision prevention system and/or auto-MARCCINO mode system and the bucket teeth enter area (D) (illustrated to the right), all functions (boom, arm, offset, bucket, swing, and travel) become inoperable. In this case, roll out the bucket forward or to the right while depressing the emergency deactivation switch. Then, restart the engine, All functions will become operable. However, if this status has occurred, immediately stop machine operation. Then, ask the authorized your dealer to inspect the machine.

NOTE: In case the bucket enters area (d) due to the cylinder drift while the machine is parked, only the boom raise, arm roll-in, and left offset functions will become inoperable. Therefore, take care not to collide the cab with the bucket when operating the bucket.

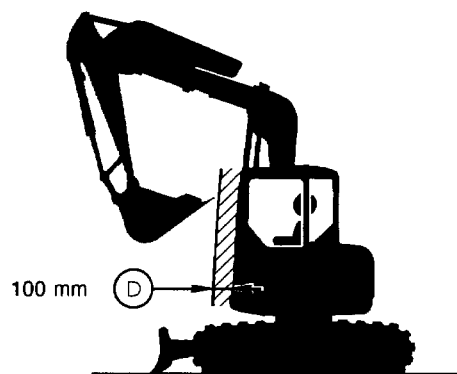

M190-05-070

OPERATING THE MACHINE

BOOM LOWERING METHOD WHEN EMERGENCY OR ENGINE STALL

CAUTION: Do not enter below the boom during operation.

If the engine stalls and is impossible to restart, lower the bucket to the ground by taking the following emergency measures.

1. Remove rubber caps ① and ② from the boom 1 section on the 4-spool control valve.
2. Using a wrench or spanner, loosen to remove lock nut ⑧ (wrench size: 17).
3. Using hexagonal wrench (size: 4), turn screw ⑦ clockwise until it becomes tight.
4. Using a wrench or spanner, slightly loosen lock nut ⑤ (wrench size: 17).
5. Using hexagonal wrench (size: 4), turn screw ⑥ clockwise to lower the boom while adjusting the boom lowering speed. At this time, do not remove snap ring ③, washer ④. Take care not to turn screw ⑥ too much as washer ④ is deformed.
6. After lowering the boom, turn screws ⑦ and ⑥ until they stop. Then, turn screw ⑦ clockwise 1/8 turns. Tighten lock nuts ⑤ and ⑧.

Torque Specification : 19.5 N·m (2 kgf·m)

7. Install rubber caps ① and ② to the correct positions.

NOTE: Be sure to turn screws ⑦ first and turn screw ⑥ next.

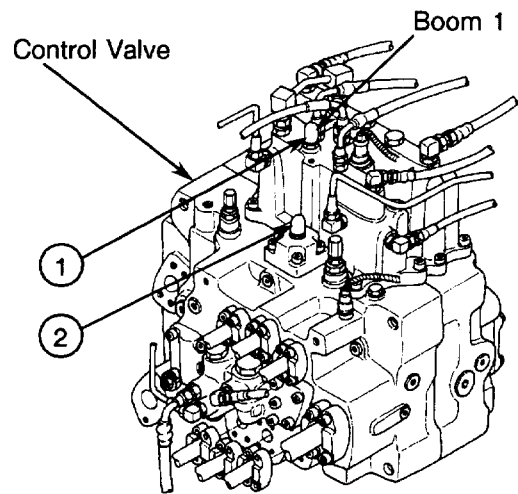

M155-05-030

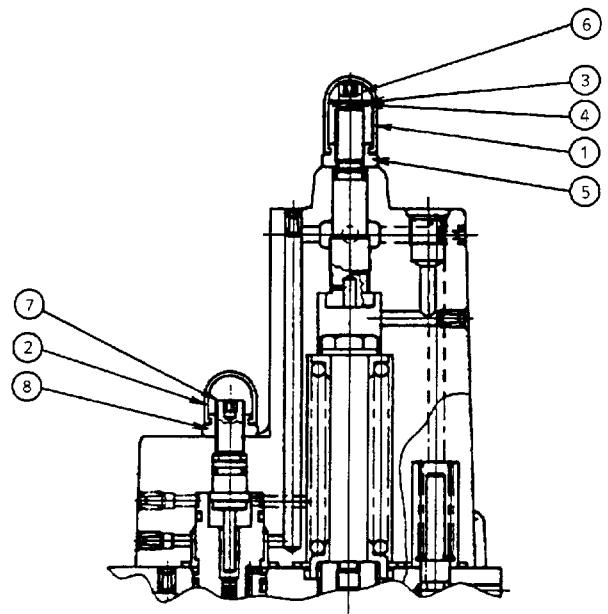

M155-05-029

MAINTENANCE

PREPARE MACHINE FOR MAINTENANCE

Before performing the maintenance procedures given in the following chapters, park the machine as described below, unless otherwise specified.

1. Park the machine on a level surface.
2. Lower the bucket and blade to the ground.
3. Turn the auto-idle switch off.

IMPORTANT: The turbocharger may be damaged if the engine is not properly shut down.

4. Run the engine at slow idle speed without load for five minutes.
5. Turn the key switch OFF. Remove key from switch. (If maintenance must be performed with engine running, do not leave machine unattended.)
6. Pull pilot control shut-off lever ① to the LOCK position.
7. Before performing any work on the machine, attach a "Do Not Operate" tag on the right control lever.

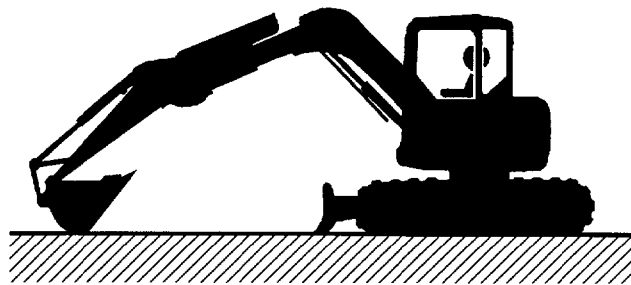

M191-07-023

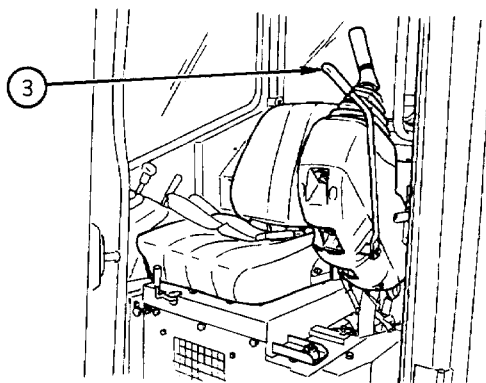

M191-03-009



SA-287

MAINTENANCE

3 Swing Internal Gear --- every 500 hours

CAUTION: Adding or changing swing internal gear grease and rotating the upperstructure must be done by one person. Before you start, clear the area of all persons.

Each time you leave the cab

- Lower the bucket and blade to the ground.
- Stop the engine.
- Pull the pilot control shut-off lever to the LOCK position.
- Use handrails.

1. Park the machine on a level surface.
2. Lower the bucket to the ground.
3. Turn the auto-idle switch off.

IMPORTANT: The turbocharger may be damaged if the engine is not properly shut down.

4. Run the engine at slow idle speed without load for five minutes.
5. Turn the key switch OFF. Remove the key from the key switch.
6. Pull the pilot control shut-off lever to the LOCK position.
7. Remove cover ① from the upperstructure side.
8. Grease must be to the top of all internal gear teeth of the swing bearing and be free of contamination. Add approximately 0.5 kg (1.1 lb) of grease, if required. If the grease is contaminated, remove grease and replace with clean grease.

IMPORTANT: If water or mud is found in the swing gear area, see Operating in Water or Mud in the "Driving the Machine" section.

9. Install the cover.
10. If grease shows any sign of water or mud, replace all the grease on the internal gear. Remove cover ② from the bottom of the swing gear housing, located near the center joint.

Grease capacity : 5 L (1.3 US gal)

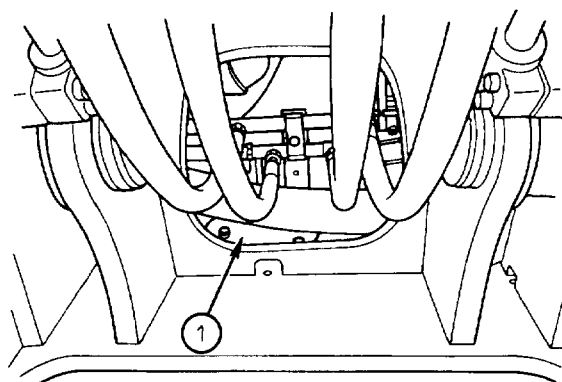

M191-07-012

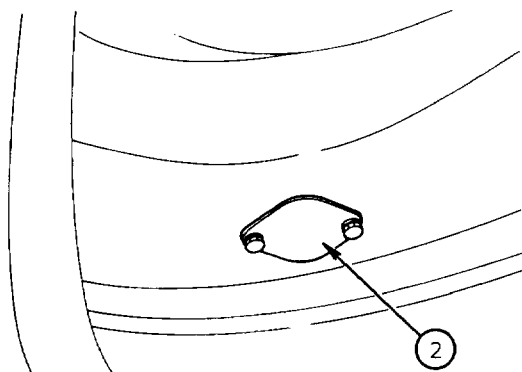

M191-07-064

MAINTENANCE

D. HYDRAULIC SYSTEM

Parts	Quantity	Interval (hours)								
		8	50	100	250	500	1 000	1 500	2 500	4 000
1. Check Hydraulic Oil Level	1									
2. Drain Hydraulic Oil Tank Sump	1									
3. Change Hydraulic Oil	120 L (31.7 US gal)							※	※	※
4. Clean Suction Filter	1	When changing hydraulic oil								
5. Replace Hydraulic Oil Filter	1									
6. Replace Pilot Filter	1									
7. Check Hoses and Lines	for leaks									
	for cracks, bend, etc.									

NOTE: ※ Hydraulic oil changing interval differs according to the kind of hydraulic oil used. See recommended oil chart.

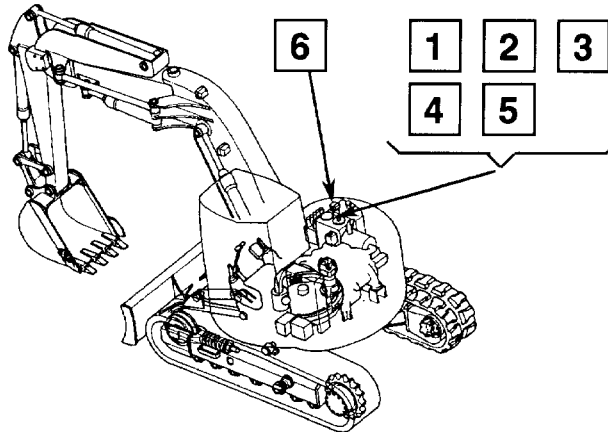

Brand Names of Recommended Hydraulic Oil

M191-07-004

Kind of Lubricant	Hydraulic Oil					
Where to be applied	Hydraulic System					
Change Interval	4 000 hours		2 500 hours		1 500 hours	
Environmental Temp.	-20 to 40 °C	-10 to 40 °C	-20 to 40 °C	-10 to 40 °C	-20 to 40 °C	-10 to 40 °C
Manufacturer	(-4 to 104 °F)	(14 to 104 °F)	(-4 to 104 °F)	(14 to 104 °F)	(-4 to 104 °F)	(14 to 104 °F)
Hitachi	Super EX 46HN					
Apollo America			Super Hydro 46 WRHU			
British Petroleum					Bartran HV46	
Caltex Oil						Rando Oil HD46
Texaco INC.						Rando Oil HD46
Chevron U.S.A INC.						Chevron AW46
Esso						NUTO H46
Mobil Oil						DTE 25
Shell Oil				Tellus Oil R46		Tellus Oil 46
Remarks	Anti-wear type hydraulic oil					

- Use proper hydraulic oil in accordance with the atmospheric temperature.

NOTE: The machine shipped from the factory is filled with oil marked .

MAINTENANCE

Table 2. Lines

Interval(hours)	Check Points	Abnormalities	Remedies
Daily	Contact surfaces of flange joints	Leak ⑪	Replace
	Bolts	Loose and leak ⑪	Replace O-ring and/or retighten bolts
	Welded surfaces on joints	Leak ⑫	Replace
Every 250 hours	Joint neck	Crack ⑬	Replace
	Welded surfaces on joints	Crack ⑫	Replace
	Clamps	Missing	Replace
		Deformation Loose	Replace Retighten

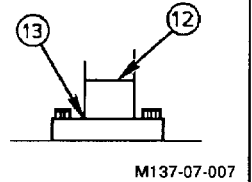
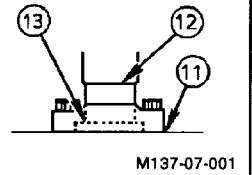

Fig. 2

NOTE : Refer to the illustrations in Fig.2 for each check point location or for a description of the abnormality.
Use genuine Hitachi parts.

Table 3. Oil-cooler

Interval(hours)	Check Points	Abnormalities	Remedies
Every 250 hours	Contact surfaces of flange joints	Leak ⑭	Replace O-ring and/or retighten bolts
	Oil-cooler	Leak ⑮	Replace
	Coupling and rubber hose	Leak ⑯	Retighten or replace

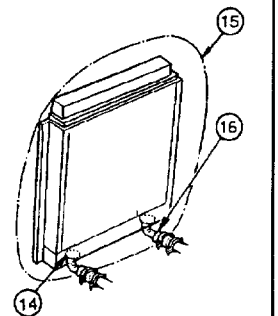

Fig. 3

NOTE : Refer to the illustrations in Fig.3 for each check point location .

MAINTENANCE

F. AIR CLEANER

Parts		Quantity	Interval (hours)						
			8	50	100	250	500	1 000	2 000
1. Air Cleaner Element	Cleaning	1	(Or when indicator lit)						
	Replacement	1	After cleaning 6 times or 1 year						

1 Clean the Air Cleaner Element
--- every 250 hours or when the restriction indicator comes ON

Replace the Air Cleaner Elements
--- after cleaning six times or after one year, whichever comes first.

1. Park the machine on a level surface.
2. Lower the bucket and blade to the ground.
3. Turn the auto-idle switch off.
4. Run the engine at slow idle speed without load for five minutes.
5. Stop the engine. Remove the key from the key switch.
6. Pull the pilot control shut-off lever to the LOCK position.
7. Loosen wing nut ② to remove cover ③.
8. Loosen wing nut ④ to pull out and remove element ①.
9. Tap element ① with the palm of your hand, NOT ON A HARD SURFACE.

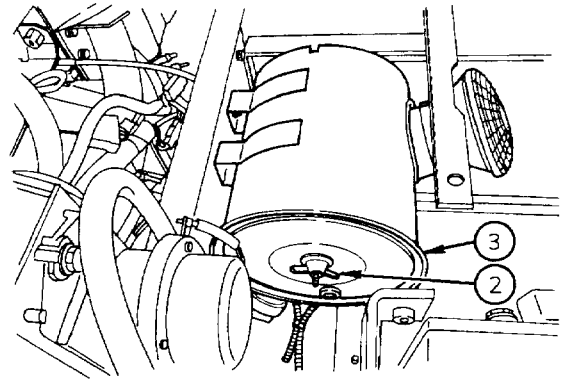

M191-07-032

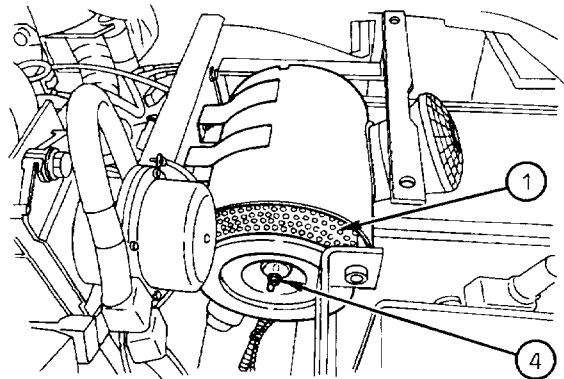

M191-07-033

⚠ CAUTION: Use reduced compressed air pressure (less than 0.2 MPa, 2 kgf/cm²). Clear area of bystanders, guard against flying chips, and wear personal protection equipment including goggles or safety glasses.

10. Clean element ① using compressed air. Direct the air to the inside of the filter element, blowing outwards.
11. Clean the filter interior before installing element ①.
12. Install element ①.
13. Install wing nut ④.
Install cover ③ and wing nut ②.
14. Start the engine and run at slow idle.
15. Check the air filter restriction indicator on the monitor panel. If the air filter restriction indicator comes ON, stop the engine and replace the element ① with a new one even if element ① has not been cleaned six times.

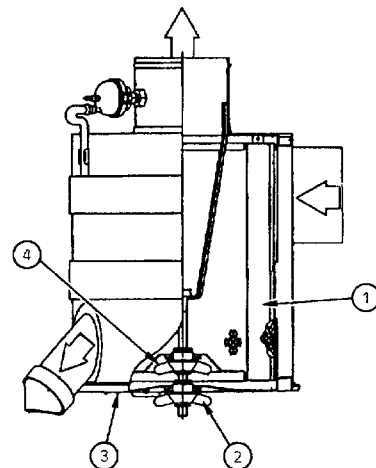

M191-07-034

MAINTENANCE

I. MISCELLANEOUS

Parts	Quantity	Interval (hours)							
		8	50	100	250	500	1 000	2 000	4 000
1. Check Bucket Teeth for Wear and Looseness	—								
2. Change Bucket	1	As required							
3. Adjust Bucket Linkage	1	As required							
4. Check and Replace Seat Belt	1		After 3 years (Replace)						
5. Check Windshield Washer Fluid Level (If Equipped)	1	As required							
6. Check and Adjust Track Sag (Rubber Crawler)	2								
7. Check Air Conditioner	—								
8. Check Injection Nozzle	—					✱			
9. Retighten Cylinder Head Bolt	—	✱ As required							
10. Inspect and Adjust Valve Clearance	—						✱		
11. Check Fuel Injection Timing	—	✱ As required							
12. Measure Engine Compression Pressure	—						✱		
13. Check Starter and Alternator	—						✱		
14. Change Water Pump Grease	—								✱
15. Check Tightening Torque of Bolts and Nuts	—		★★						

NOTE: ★★ Maintenance required only during first time check.

✱ Contact your authorized dealer for maintenance.

Greasing decal is positioned at the underside of the fuel filler access cover.

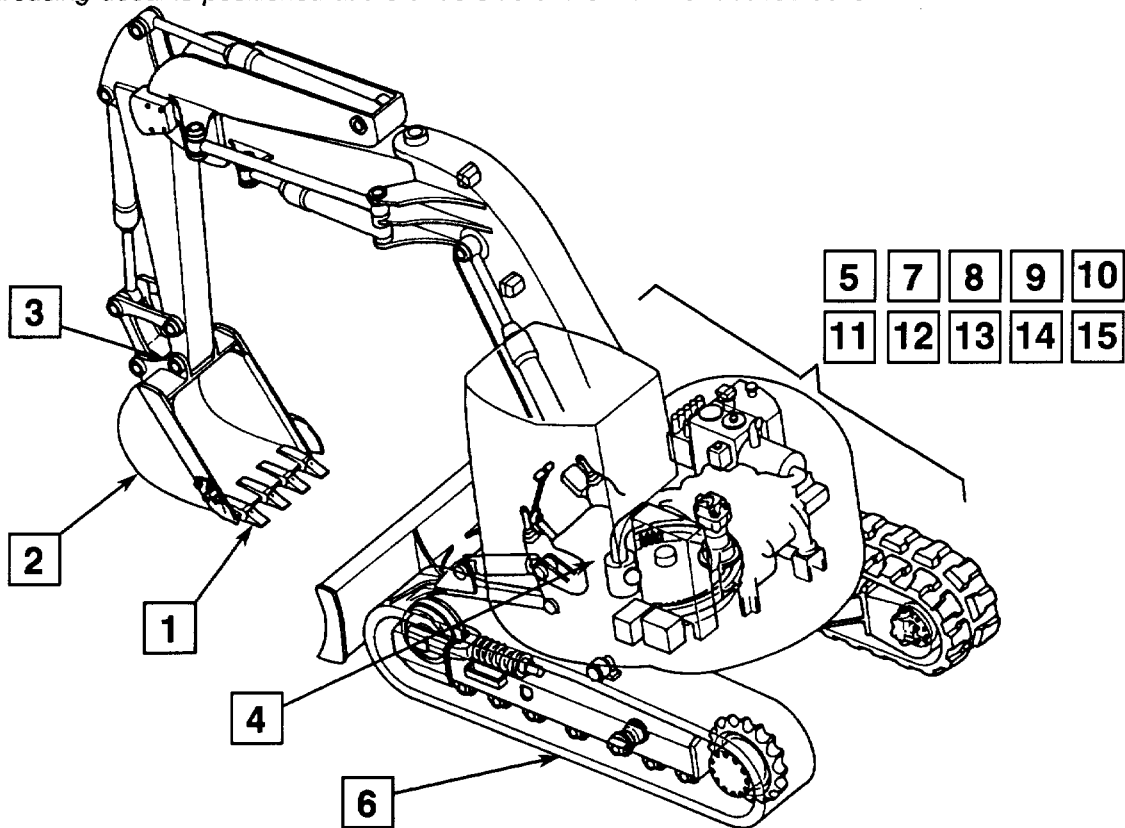

M191-07-004

MAINTENANCE

- 8** Check Injection Nozzle
--- every 500 hours

See your authorized dealer.

- 9** Retighten Cylinder Head Bolt
--- daily

See your authorized dealer.

- 10** Inspect and Adjust Valve Clearance
--- every 1 000 hours

See your authorized dealer.

- 11** Check Fuel Injection Timing
--- daily

See your authorized dealer.

MAINTENANCE

MAINTENANCE UNDER SPECIAL ENVIRONMENTAL CONDITIONS

Operating Conditions	Precautions for Maintenance	
Muddy Soil, Rainy or Snowy Weather	Before Operation: After Operation:	Check the tightness of plugs and all drain cocks. Clean the machine and check for cracks, damaged, loose or missing bolts and nuts. Lubricate all necessary parts without delay.
Near the Ocean	Before Operation: After Operation:	Check tightness of plugs and all drain cocks. Thoroughly clean the machine with fresh water to wash off salt. Service electrical equipment often to prevent corrosion.
Dusty Atmosphere	Air Cleaner: Radiator: Fuel System: Electrical Equipment:	Clean the element regularly at shorter service intervals. Clean the oil cooler screen to prevent clogging of the radiator core. Clean the filter element and strainer regularly at shorter service intervals. Clean them regularly, in particular, the commutator surface of the alternator and starter.
Rocky Ground	Tracks: Front Attachment:	Carefully operate while checking for cracks, damage and loose bolts and nuts. Loosen the tracks a little more than usual. Standard attachment may be damaged when digging rocky ground. Reinforce the bucket before using it, or use a heavy duty bucket.
Freezing Weather	Fuel: Lubricant: Engine Coolant: Battery: Tracks:	Use high quality fuel suitable for low temperature. Use high quality low viscosity hydraulic oil and engine oil. Be sure to use antifreeze. Fully charge the batteries regularly at shorter service intervals. If not fully charged, electrolyte may freeze. Keep the tracks clean. Park the machine on a hard surface to prevent the tracks from freezing to the ground.
Falling Stones	Cab:	Provide a cab guard to protect the machine from falling stones when necessary.

CLICK HERE TO **DOWNLOAD** THE COMPLETE MANUAL

- Thank you very much for reading the preview of the manual.
- You can download the complete manual from: www.heydownloads.com by clicking the link below



- Please note: If there is no response to CLICKING the link, please download this PDF first and then click on it.

CLICK HERE TO **DOWNLOAD** THE COMPLETE MANUAL