



# OWNER'S SERVICE MANUAL

## *WR250FR*

LIT-1

5UM-28199-10















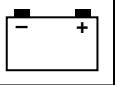

CLICK HERE TO **DOWNLOAD** THE COMPLETE MANUAL

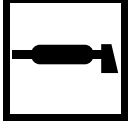
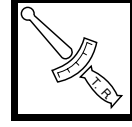
- Thank you very much for reading the preview of the manual.
- You can download the complete manual from: [www.heydownloads.com](http://www.heydownloads.com) by clicking the link below

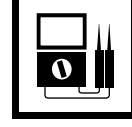

- Please note: If there is no response to CLICKING the link, please download this PDF first and then click on it.

CLICK HERE TO **DOWNLOAD** THE COMPLETE MANUAL

① GEN INFO 	② SPEC 
③ INSP ADJ 	④ ENG 
⑤ CHAS 	⑥ ELEC 
⑦ TUN 	⑧ 
⑨ 	⑩ 
⑪ 	⑫ 
⑬ 	⑭ 
⑮ 	⑯ 
⑰ 	⑱ 
⑲ 	⑳ <b>New</b>

## ILLUSTRATED SYMBOLS (Refer to the illustration)

Illustrated symbols ① to ⑦ are designed as thumb tabs to indicate the chapter's number and content.

- ① General information
- ② Specifications
- ③ Regular inspection and adjustments
- ④ Engine
- ⑤ Chassis
- ⑥ Electrical
- ⑦ Tuning

Illustrated symbols ⑧ to ⑭ are used to identify the specifications appearing in the text.

- ⑧ With engine mounted
- ⑨ Special tool
- ⑩ Filling fluid
- ⑪ Lubricant
- ⑫ Tightening
- ⑬ Specified value, Service limit
- ⑭ Resistance ( $\Omega$ ), Voltage (V), Electric current (A)

Illustrated symbols ⑮ to ⑱ in the exploded diagrams indicate grade of lubricant and location of lubrication point.

- ⑮ Apply engine oil
- ⑯ Apply molybdenum disulfide oil
- ⑰ Apply lightweight lithium-soap base grease
- ⑱ Apply molybdenum disulfide grease

Illustrated symbols ⑲ to ⑳ in the exploded diagrams indicate where to apply a locking agent and where to install new parts.

- ⑲ Apply locking agent (LOCTITE®)
- ⑳ Use new one

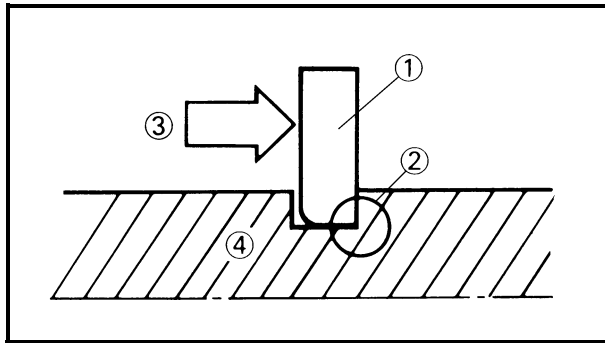

EC136000

**CIRCLIPS**

1. All circlips should be inspected carefully before reassembly. Always replace piston pin clips after one use. Replace distorted circlips. When installing a circlip ①, make sure that the sharp-edged corner ② is positioned opposite to the thrust ③ it receives. See the sectional view.

④ Shaft

## STARTING AND BREAK-IN

### ⚠ WARNING

Never start or run the engine in a closed area. The exhaust fumes are poisonous; they can cause loss of consciousness and death in a very short time. Always operate the machine in a well-ventilated area.

### CAUTION:

- The carburetor on this machine has a built-in accelerator pump. Therefore, when starting the engine, do not operate the throttle or the spark plug will foul.
- Unlike a two-stroke engine, this engine cannot be kick started when the throttle is open because the kickstarter may kick back. Also, if the throttle is open the air/fuel mixture may be too lean for the engine to start.
- Before starting the machine, perform the checks in the pre-operation check list.

### AIR FILTER MAINTENANCE

According to “AIR FILTER CLEANING” section in the CHAPTER 3, apply the foam-air-filter oil or its equivalent to the element. (Excess oil in the element may adversely affect engine starting.)

### STARTING A COLD ENGINE

#### NOTE:

This model is equipped with an ignition circuit cut-off system. The engine can be started under the following conditions.

- When the transmission is in neutral.
- When the clutch is disengaged with the transmission in any position. However, it is recommended to shift into neutral before starting the engine.

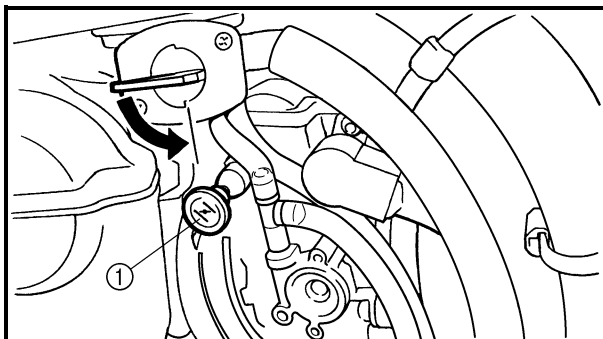

1. Inspect the coolant level.
2. Turn the fuel cock to “ON”.
3. Push on the main switch to “ON”.
4. Shift the transmission into neutral.
5. Fully open the cold starter knob ①.
6. Start the engine by pushing the start switch or by kicking the kickstarter crank.

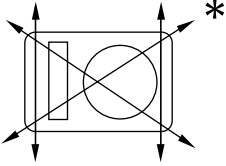
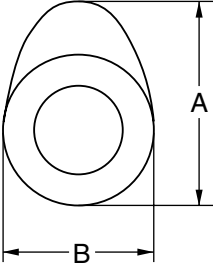
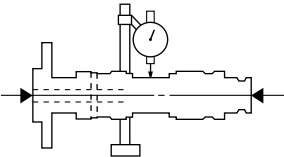

**MAINTENANCE SPECIFICATIONS  
ENGINE**

Item	Standard	Limit
Cylinder head: Warp limit 	----	0.05 mm (0.002 in)
Cylinder: Bore size Out of round limit	77.00 ~ 77.01 mm (3.0315 ~ 3.0319 in) ----	---- 0.05 mm (0.002 in)
Camshaft: Drive method Camshaft cap inside diameter Camshaft outside diameter Shaft-to-cap clearance Cam dimensions  Intake Exhaust Camshaft runout limit 	Chain drive (Left) 22.000 ~ 22.021 mm (0.8661 ~ 0.8670 in) 21.967 ~ 21.980 mm (0.8648 ~ 0.8654 in) 0.020 ~ 0.054 mm (0.0008 ~ 0.0021 in) "A" "B" "A" "B" ----	---- ---- ---- 0.08 mm (0.003 in) 30.296 ~ 30.346 mm (1.1923 ~ 1.1947 in) 22.45 ~ 22.55 mm (0.8839 ~ 0.8878 in) 30.399 ~ 30.499 mm (1.1968 ~ 1.2007 in) 22.45 ~ 22.55 mm (0.8839 ~ 0.8878 in) 0.03 mm (0.0012 in)



	Part to be tightened	Thread size	Q'ty	Tightening torque		
				Nm	m-kg	ft-lb
△	Upper bracket and outer tube	M8 × 1.25	4	23	2.3	17
△	Lower bracket and outer tube	M8 × 1.25	4	20	2.0	14
△	Upper bracket and steering stem	M24 × 1.0	1	145	14.5	105
△	Handlebar upper holder and upper bracket	M8 × 1.25	4	28	2.8	20
△	Steering stem and steering ring nut	M28 × 1.0	1	Refer to NOTE.		
	Front fork and front fork cap bolt	M48 × 1.0	2	30	3.0	22
	Front fork and base valve	M30 × 1.0	2	55	5.5	40
	Front fork cap bolt and damper rod	M12 × 1.25	2	29	2.9	21
	Front fork bleed screw and front fork cap bolt	M5 × 0.8	2	1	0.1	0.7
	Front fork and front fork protector	M6 × 1.0	6	10	1.0	7.2
	Front fork and brake hose holder	M6 × 1.0	2	10	1.0	7.2
	Front fork and brake hose cover (M8)	M8 × 1.25	1	16	1.6	11
	(M6)	M6 × 1.0	1	7	0.7	5.1
	Throttle grip cap	M5 × 0.8	2	4	0.4	2.9
△	Front brake master cylinder	M6 × 1.0	2	9	0.9	6.5
	Brake lever mounting bolt	M6 × 1.0	1	6	0.6	4.3
	Brake lever mounting nut	M6 × 1.0	1	6	0.6	4.3
	Brake lever position locknut	M6 × 1.0	1	5	0.5	3.6
	Front brake hose guide	M5 × 0.8	2	4	0.4	2.9
	Clutch lever holder	M5 × 0.8	2	4	0.4	2.9
	Hot starter lever holder	M5 × 0.8	2	4	0.4	2.9
	Hot starter lever mounting nut	M5 × 0.8	1	2	0.2	1.4
	Light switch	M4 × 0.7	2	2	0.2	1.4
	Front brake master cylinder cap	M4 × 0.7	2	2	0.2	1.4
△	Front brake hose union bolt	M10 × 1.25	2	30	3.0	22
△	Front brake caliper	M8 × 1.25	2	23	2.3	17
	Pad pin plug	M10 × 1.0	2	3	0.3	2.2
△	Front brake caliper and pad pin	M10 × 1.0	1	18	1.8	13
△	Rear brake caliper and pad pin	M10 × 1.0	1	18	1.8	13
△	Brake caliper and bleed screw	M8 × 1.25	2	6	0.6	4.3
△	Front wheel axle and axle nut	M16 × 1.5	1	105	10.5	75
△	Front wheel axle holder	M8 × 1.25	4	23	2.3	17
△	Front brake disc	M6 × 1.0	6	12	1.2	8.7
△	Rear brake disc	M6 × 1.0	6	14	1.4	10
△	Brake pedal	M8 × 1.25	1	26	2.6	19
△	Rear brake master cylinder	M6 × 1.0	2	11	1.1	8.0
	Rear brake master cylinder cap	M4 × 0.7	2	2	0.2	1.4
△	Rear brake hose union bolt	M10 × 1.25	2	30	3.0	22
△	Rear wheel axle and axle nut	M20 × 1.5	1	125	12.5	90

**NOTE:**

1. First, tighten the steering nut approximately 38 Nm (3.8 m • kg, 27 ft • lb) by using the steering nut wrench, then loosen the steering nut one turn.
2. Retighten the steering nut 7 Nm (0.7 m • kg, 5.1 ft • lb).

# CABLE ROUTING DIAGRAM

**SPEC**



- ① Hot starter cable
- ② Cable guide
- ③ Throttle cable (return)
- ④ Throttle cable (pull)
- ⑤ Ignition coil
- ⑥ Coolant reservoir breather hose
- ⑦ Rectifier/regulator
- ⑧ Coolant reservoir hose
- ⑨ Rectifier/regulator lead

- ⑩ Clamp
  - ⑪ CDI unit lead
  - ⑫ CDI unit
  - ⑬ CDI unit band
  - ⑭ CDI unit stay
  - ⑮ Rectifier/regulator bracket
- A** Pass the throttle cables and hot starter cable through the cable guides.

- B** Pass the throttle cables and hot starter cable between the radiator and frame, then under the radiator mounting boss.
- C** Pass the throttle cables on the outside of the ignition coil.
- D** Pass the carburetor breather hose (of the throttle cable cover) through the hose holder.

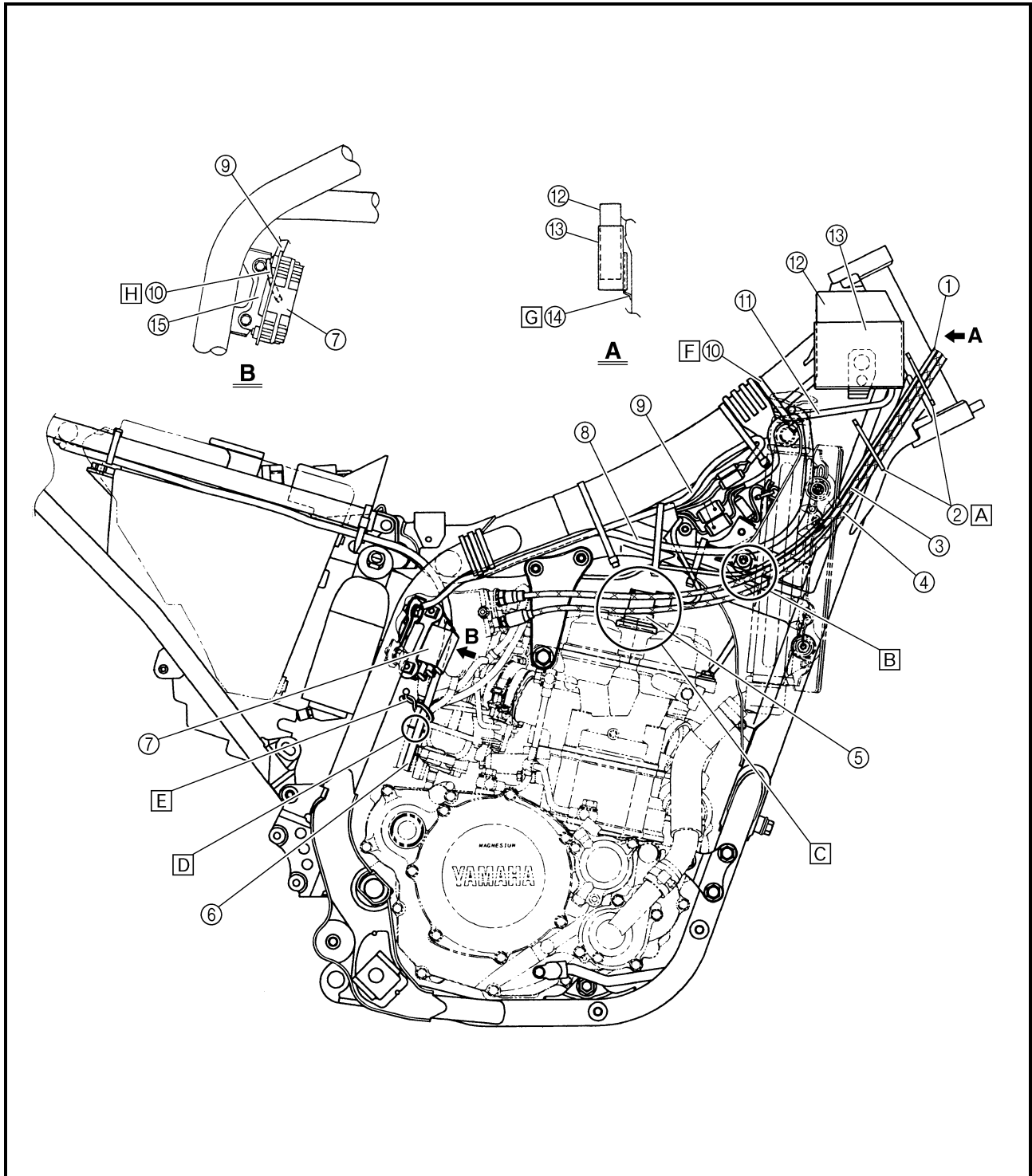

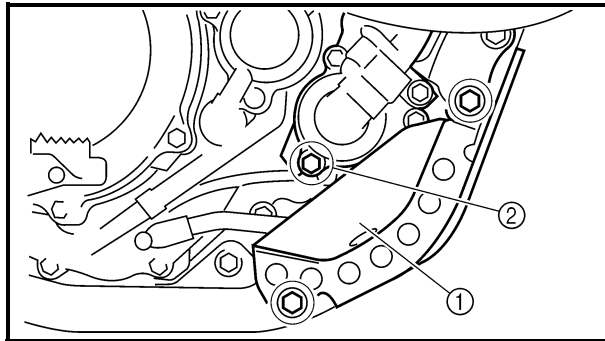
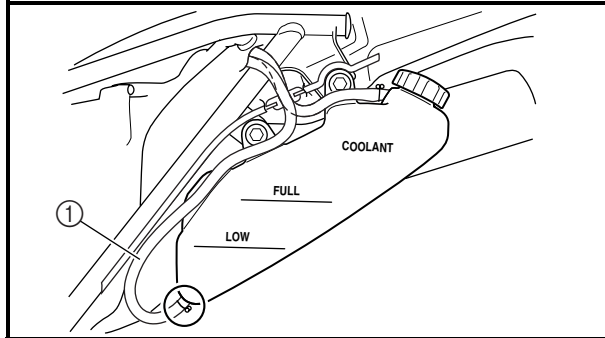

**CAUTION:**

Take care so that coolant does not splash on painted surfaces. If it splashes, wash it away with water.



1. Place a container under the engine.
2. Remove:
  - Seat  
Refer to “SEAT, FUEL TANK AND SIDE COVERS” section in the CHAPTER 4.
3. Disconnect:
  - Coolant reservoir hose ①  
Drain the coolant completely.
4. Connect:
  - Coolant reservoir hose
5. Remove:
  - Engine guard ①
  - Coolant drain bolt ②
6. Remove:
  - Radiator cap  
Drain the coolant completely.
7. Clean:
  - Cooling system  
Thoroughly flush the cooling system with clean tap water.
8. Install:
  - Copper washer **New**
  - Coolant drain bolt  

	<b>10 Nm (1.0 m · kg, 7.2 ft · lb)</b>
---	--
  - Engine guard
  - Bolt [engine guard (front)]  

	<b>34 Nm (3.4 m · kg, 24 ft · lb)</b>
---	---------------------------------------
  - Bolt [engine guard (rear)]  

	<b>23 Nm (2.3 m · kg, 17 ft · lb)</b>
---	---------------------------------------

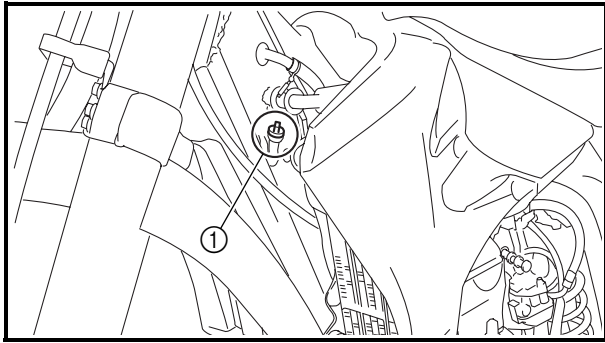

4. Remove:

- Oil tank cap ①
- Oil filler cap ②
- Frame oil drain bolt ③
- Crankcase oil drain bolt ④
- Oil filter element drain bolt ⑤

Drain the crankcase and oil tank (frame) of its oil.

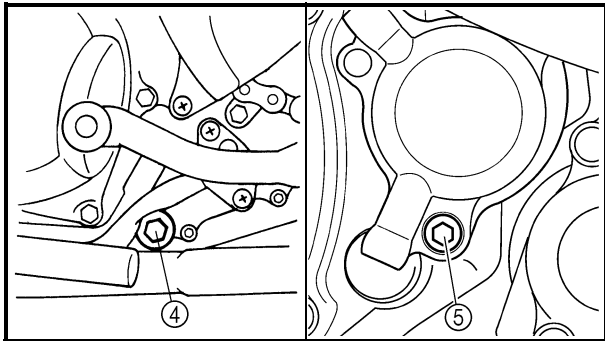
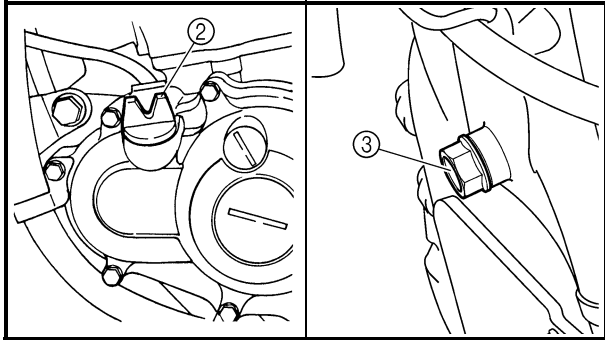

5. Remove:

- Lower engine bracket
- Oil hose clamp ①
- Bolt (oil hose) ②
- Oil hose ③
- Oil strainer (frame) ④

6. Inspect:

- Oil strainer (frame)
- Clogged → Blow.

7. If the oil filter is to be replaced during this oil change, remove the following parts and reinstall them.

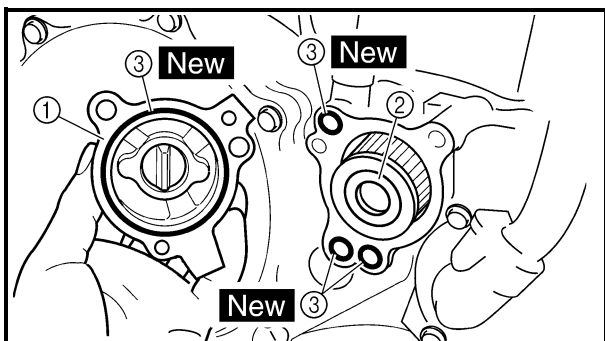
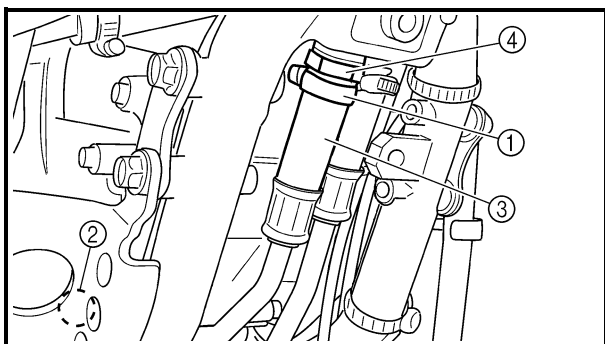

**Replacement steps:**

- Remove the oil filter element cover ① and oil filter element ②.
- Check the O-rings ③, if cracked or damaged, replace them with a new one.
- Install the oil filter element and oil filter element cover.



**Oil filter element cover:**  
10 Nm (1.0 m • kg, 7.2 ft • lb)

**NOTE:** \_\_\_\_\_  
 If bleeding is difficult, it may be necessary to let the brake fluid system stabilize for a few hours. Repeat the bleeding procedure when the tiny bubbles in the system have disappeared.

j. Add brake fluid to the level line on the reservoir.

**⚠ WARNING** \_\_\_\_\_  
**Check the operation of the brake after bleeding the brake system.**

3. Install:
- Protector (rear brake)
  - Diaphragm
  - Brake master cylinder cap

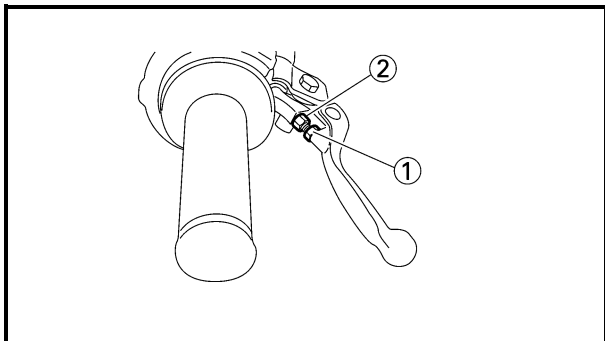
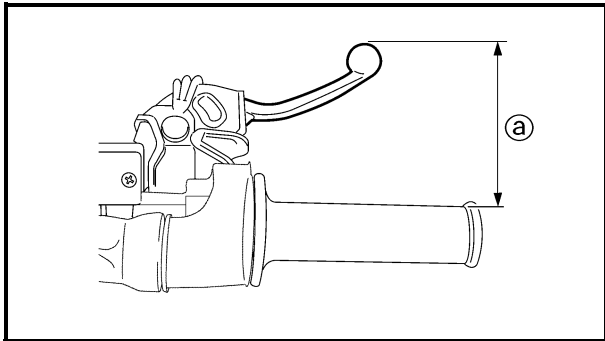

EC362040  
**FRONT BRAKE ADJUSTMENT**

1. Check:
- Brake lever position ①

 <b>Brake lever position ①:</b>	
<b>Standard position</b>	<b>Extent of adjustment</b>
<b>95 mm (3.74 in)</b>	<b>76 ~ 97 mm (2.99 ~ 3.82 in)</b>

2. Remove:
- Brake lever cover
3. Adjust:
- Brake lever position

**Brake lever position adjustment steps:**

- Loosen the locknut ①.
- Turn the adjusting bolt ② until the lever position ① is within specified position.
- Tighten the locknut.

 **Locknut:**  
**5 Nm (0.5 m • kg, 3.6 ft • lb)**

**CAUTION:** \_\_\_\_\_  
**Be sure to tighten the locknut, as it will cause poor brake performance.**

4. Install:
- Brake lever cover

# FRONT FORK INTERNAL PRESSURE RELIEVING/FRONT FORK REBOUND DAMPING FORCE ADJUSTMENT

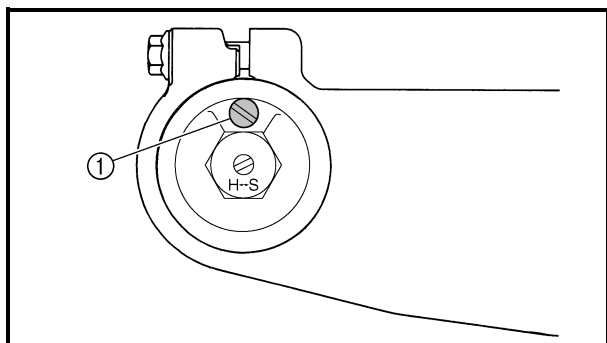

## FRONT FORK INTERNAL PRESSURE RELIEVING

**NOTE:** \_\_\_\_\_  
 If the front fork initial movement feels stiff during a run, relieve the front fork internal pressure.

1. Elevate the front wheel by placing a suitable stand under the engine.
2. Remove the air bleed screw ① and release the internal pressure from the front fork.
3. Install:

- Air bleed screw

1 Nm (0.1 m · kg, 0.7 ft · lb)

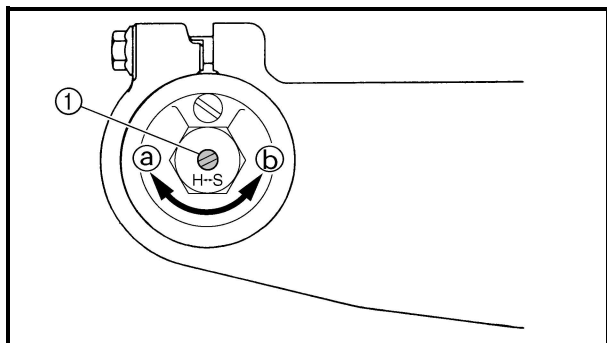

## EC36H002 FRONT FORK REBOUND DAMPING FORCE ADJUSTMENT

1. Adjust:
  - Rebound damping force
  - By turning the adjuster ①.

**Stiffer (a) → Increase the rebound damping force. (Turn the adjuster ① in.)**  
**Softer (b) → Decrease the rebound damping force. (Turn the adjuster ① out.)**

<b>Extent of adjustment:</b>	
<b>Maximum</b>	<b>Minimum</b>
Fully turned in position	20 clicks out (from maximum position)

**LUBRICATION**

To ensure smooth operation of all components, lubricate your machine during setup, after break-in, and after every race.

- ① All control cable
- ② Clutch lever pivot
- ③ Shift pedal pivot
- ④ Footrest pivot
- ⑤ Throttle-to-handlebar contact
- ⑥ Drive chain
- ⑦ Tube guide cable winding portion
- ⑧ Throttle cable end
- ⑨ Clutch cable end
- ⑩ Hot starter cable end

- A** Use Yamaha cable lube or equivalent on these areas.
- B** Use SAE 10W-30 motor oil or suitable chain lubricants.
- C** Lubricate the following areas with high quality, lightweight lithium-soap base grease.

**CAUTION:** Wipe off any excess grease, and avoid getting grease on the brake discs.

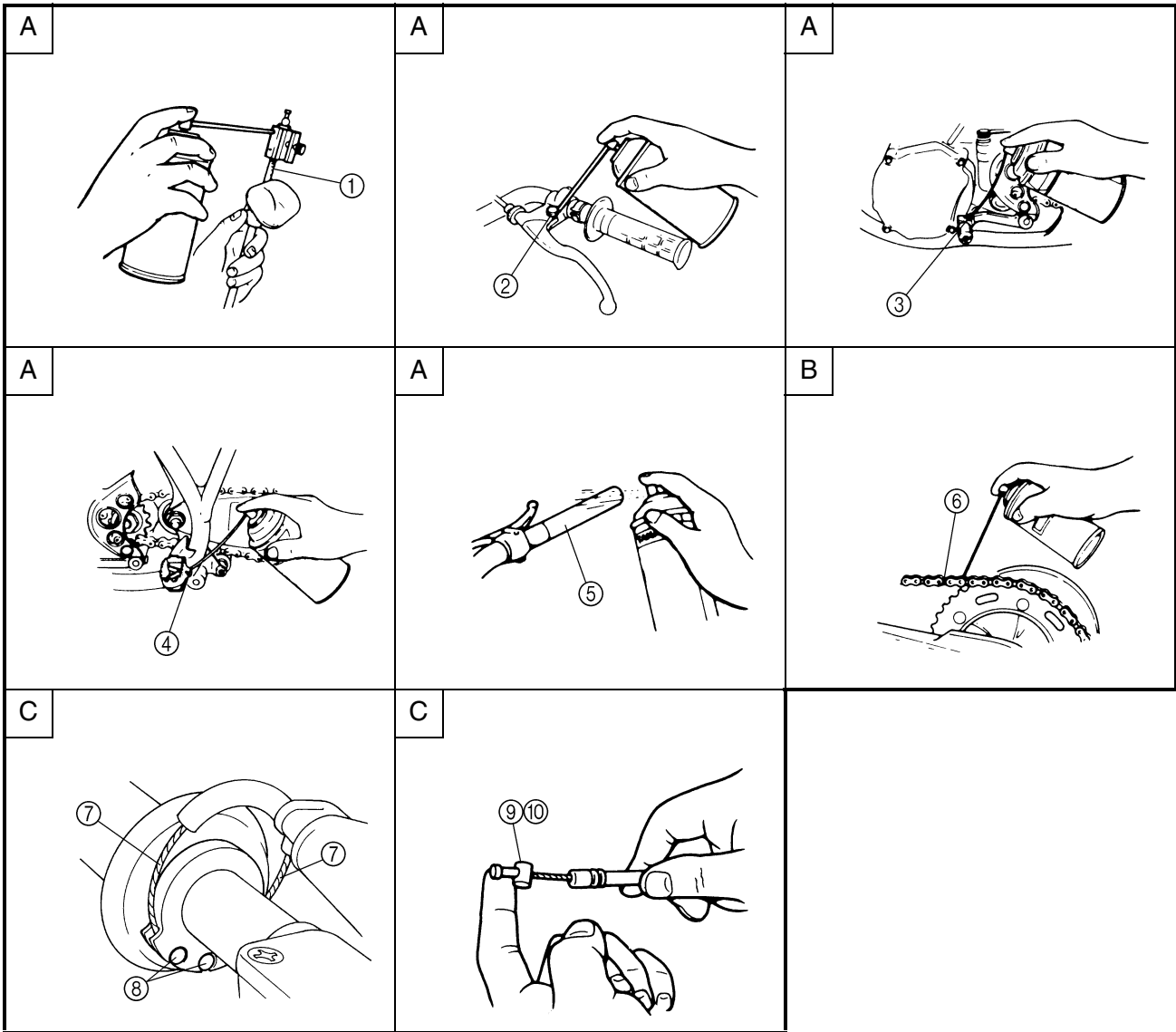

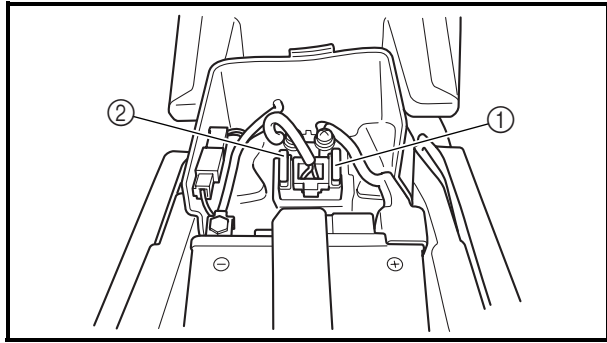

2. Check:
  - Continuity

**Checking steps:**

- Remove the fuse ①.
- Connect the pocket tester to the fuse and check the continuity.

**NOTE:**

Set the pocket tester selector to " $\Omega \times 1$ ".



**Pocket tester:**  
YU-3112-C/90890-03112

- If the pocket tester indicates " $\infty$ ", replace the fuse.

- ② Reserve fuse

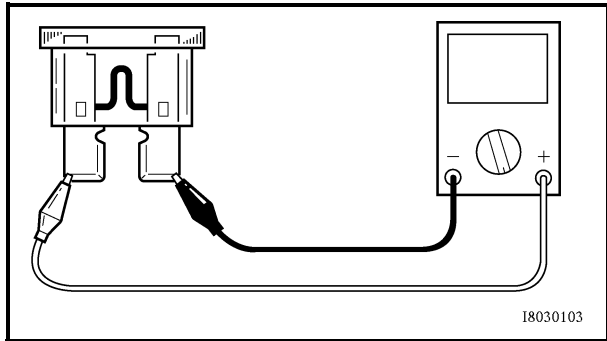

3. Replace:
  - Blown fuse

**Replacement steps:**

- Set the main switch to "OFF".
- Install a new fuse of the correct amperage.
- Set on the switches to verify if the electrical circuit is operational.
- If the fuse immediately blows again, check the electrical circuit.

Items	Amperage rating	Q'ty
Main fuse	10 A	1

**⚠ WARNING**

Never use a fuse with an amperage rating other than that specified. Improvising or using a fuse with the wrong amperage rating may cause extensive damage to the electrical system, cause the starting and ignition systems to malfunction and could possibly cause a fire.

4. Install:
  - Fuse cover
  - Seat



EC468000

CARBURETOR DISASSEMBLY

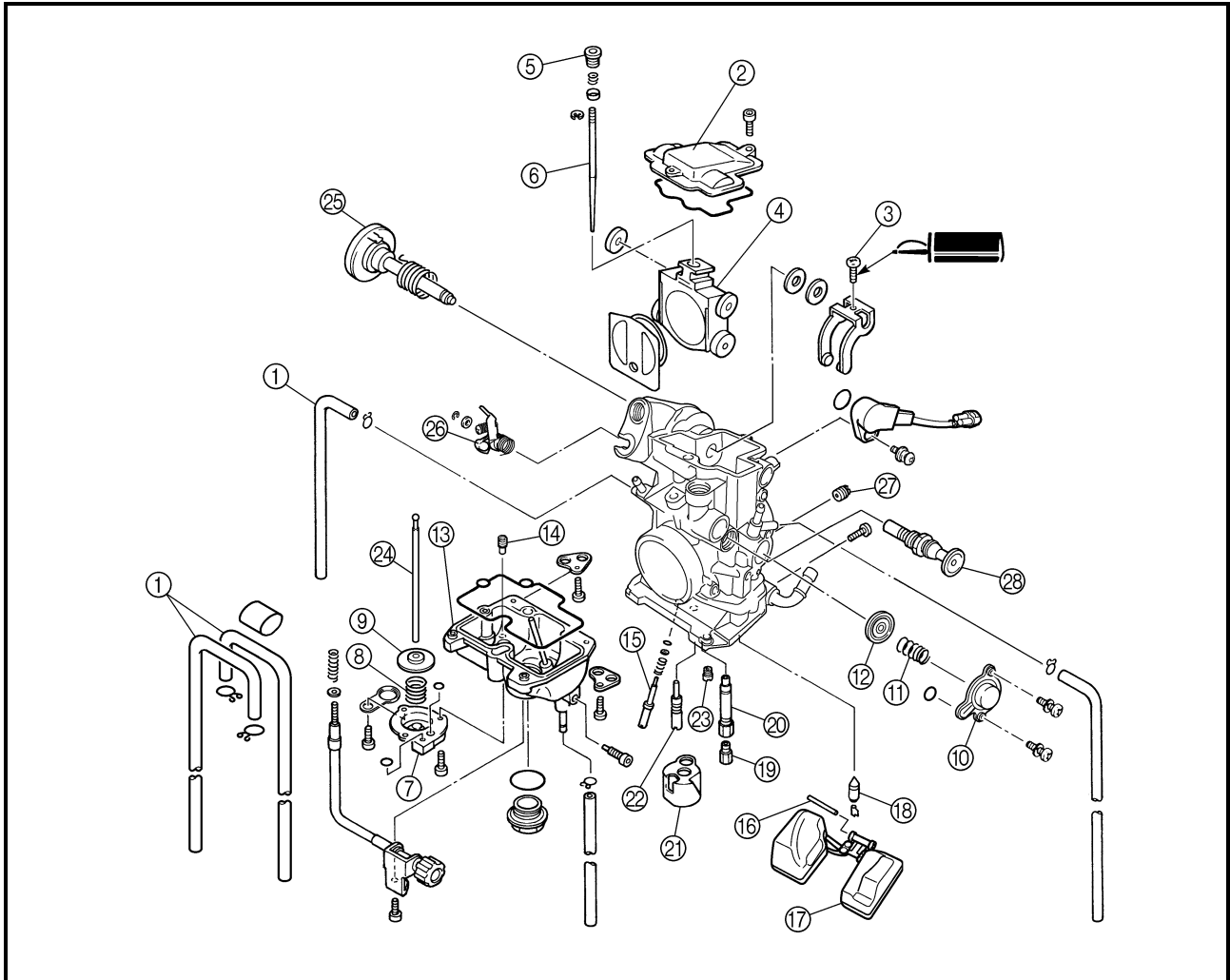

Extent of removal: ① Carburetor disassembly

Extent of removal	Order	Part name	Q'ty	Remarks
		<b>CARBURETOR DISASSEMBLY</b>		
	①	Carburetor breather hose	4	
	②	Valve lever housing cover	1	
	③	Screw (throttle shaft)	1	
	④	Throttle valve	1	
	⑤	Needle holder	1	
	⑥	Jet needle	1	
	⑦	Accelerator pump cover	1	
	⑧	Spring	1	
	⑨	Diaphragm (accelerator pump)	1	
	⑩	Air cut valve cover	1	
	⑪	Spring (air cut valve)	1	
	⑫	Diaphragm (air cut valve)	1	
	⑬	Float chamber	1	
	⑭	Leak jet	1	
⑮	Pilot screw	1	Refer to "REMOVAL POINTS".	

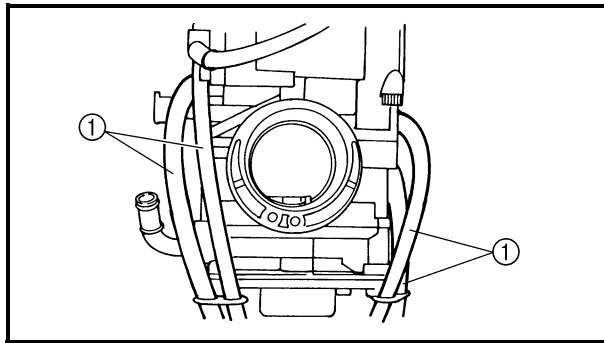

19. Install:

- Carburetor breather hose ①

**NOTE:**

Install the carburetor breather hoses to the carburetor so that the hoses do not bend near where they are installed.

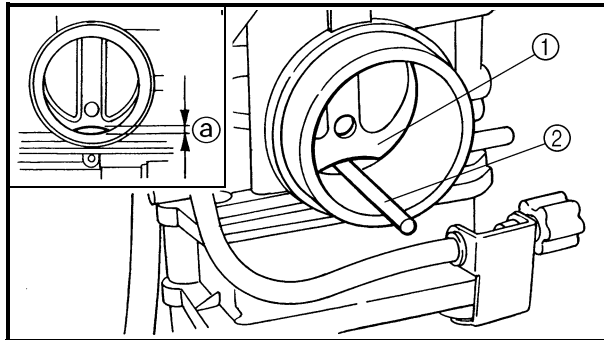

### Accelerator pump timing adjustment

**Adjustment steps:**

**NOTE:**

In order for the throttle valve height (a) to achieve the specified value, tuck under the throttle valve plate (1) the rod (2) etc. with the same outer diameter as the specified value.

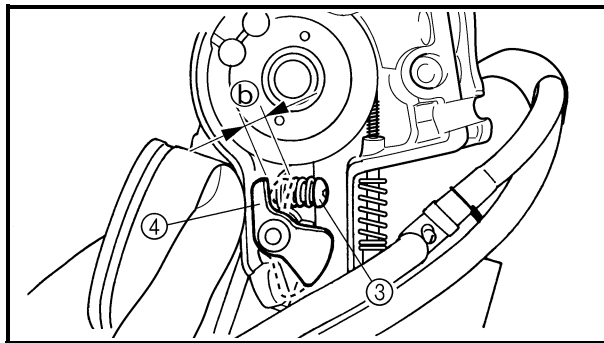

**Throttle valve height:**  
1.5 mm (0.06 in)

- Fully turn in the accelerator pump adjusting screw (3).
- Check that the link lever (4) has free play (b) by pushing lightly on it.
- Gradually turn out the adjusting screw while moving the link lever until it has no more free play.

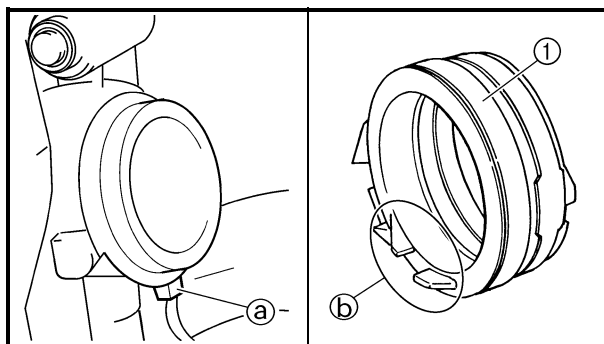

### Carburetor installation

1. Install:

- Carburetor joint ①

3 Nm (0.3 m · kg, 2.2 ft · lb)

**NOTE:**

Install the projection (a) on the cylinder between the carburetor joint slots (b).

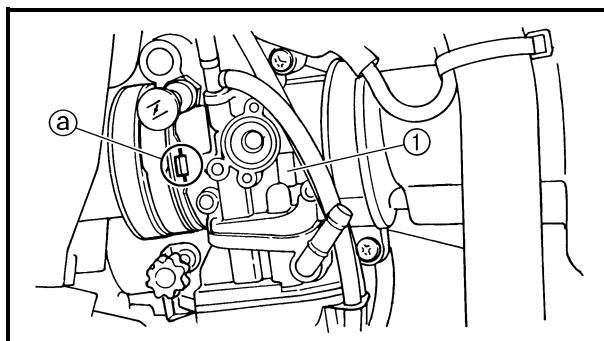

2. Install:

- Carburetor ①

**NOTE:**

Install the projection (a) between the carburetor joint slots.

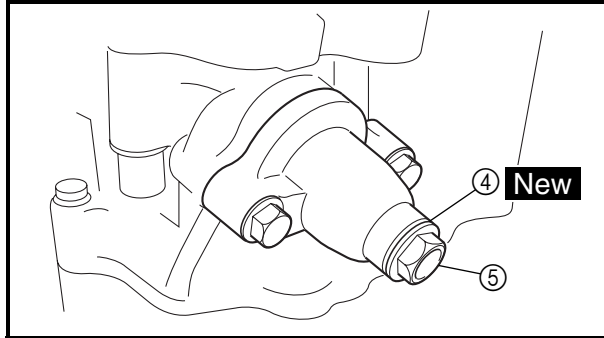
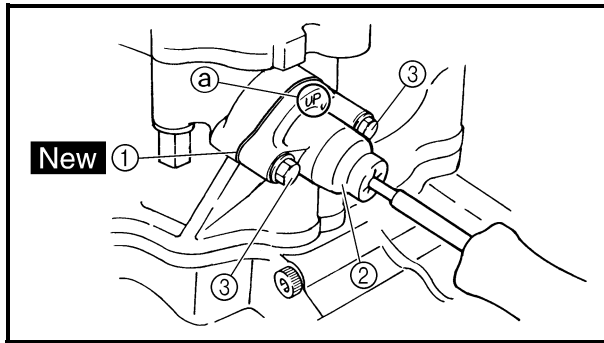

- With the rod fully wound and the chain tensioner UP mark (a) facing upward, install the gasket (1) and the timing chain tensioner (2), and tighten the bolt (3) to the specified torque.



**Bolt (timing chain tensioner):**  
10 Nm (1.0 m • kg, 7.2 ft • lb)

- Release the screwdriver, check the tensioner rod to come out and tighten the gasket (4) and the cap bolt (5) to the specified torque.



**Tensioner cap bolt:**  
7 Nm (0.7 m • kg, 5.1 ft • lb)

- Turn:
  - Crankshaft  
Counterclockwise several turns.
- Check:
  - Rotor T.D.C. mark  
Align with the crankcase align mark.
  - Camshaft match marks  
Align with the cylinder head surface.  
Out of alignment → Adjust.

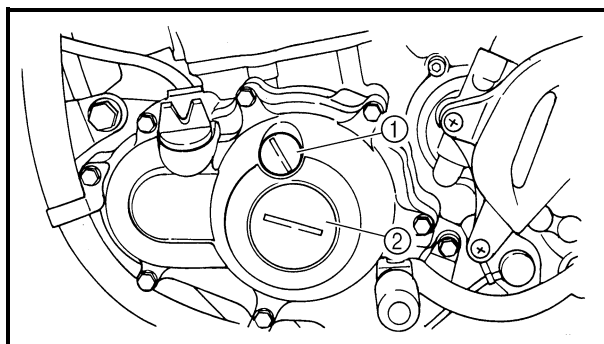

- Install:
  - Timing mark accessing screw (1)
  - Crankshaft end accessing screw (2)



9. Lap:
- Valve face
  - Valve seat

**NOTE:** \_\_\_\_\_

After refacing the valve seat or replacing the valve and valve guide, the valve seat and valve face should be lapped.

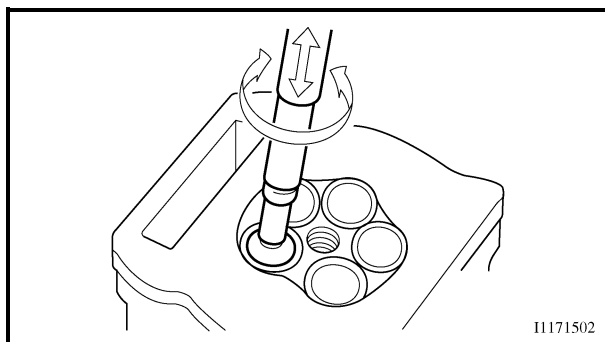
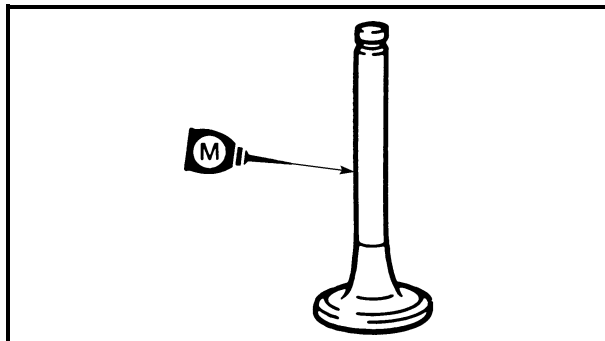
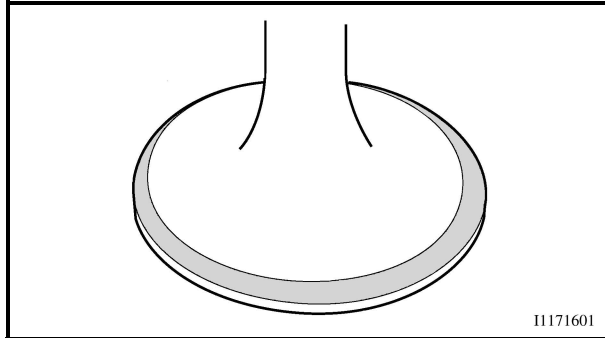

**Lapping steps:**

- Apply a coarse lapping compound to the valve face.

**CAUTION:** \_\_\_\_\_

**Do not let the compound enter the gap between the valve stem and the guide.**

- Apply molybdenum disulfide oil to the valve stem.
- Install the valve into the cylinder head.
- Turn the valve until the valve face and valve seat are evenly polished, then clean off all of the compound.

**NOTE:** \_\_\_\_\_

For best lapping results, lightly tap the valve seat while rotating the valve back and forth between your hands.

- Apply a fine lapping compound to the valve face and repeat the above steps.

**NOTE:** \_\_\_\_\_

After every lapping operation be sure to clean off all of the compound from the valve face and valve seat.

- Apply Mechanic's blueing dye (Dykem) to the valve face.
- Install the valve into the cylinder head.
- Press the valve through the valve guide and onto the valve seat to make a clear pattern.
- Measure the valve seat width again. If the valve seat width is out of specification, reface and relap the valve seat.

CLICK HERE TO **DOWNLOAD** THE COMPLETE MANUAL

- Thank you very much for reading the preview of the manual.
- You can download the complete manual from: [www.heydownloads.com](http://www.heydownloads.com) by clicking the link below



- Please note: If there is no response to CLICKING the link, please download this PDF first and then click on it.

CLICK HERE TO **DOWNLOAD** THE COMPLETE MANUAL

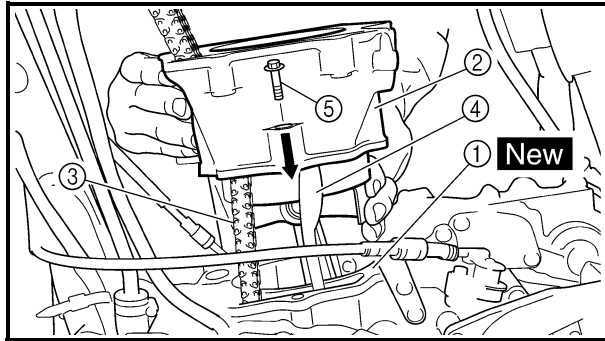

## 3. Install:

- Cylinder gasket ① **New**
- Cylinder ②

**NOTE:**

Install the cylinder with one hand while compressing the piston rings with the other hand.

**CAUTION:**

- Pass the timing chain ③ through the timing chain cavity.
- Be careful not to damage the timing chain guide ④ during installation.

## 4. Install:

- Bolt (cylinder) ⑤

 **10 Nm (1.0 m · kg, 7.2 ft · lb)**

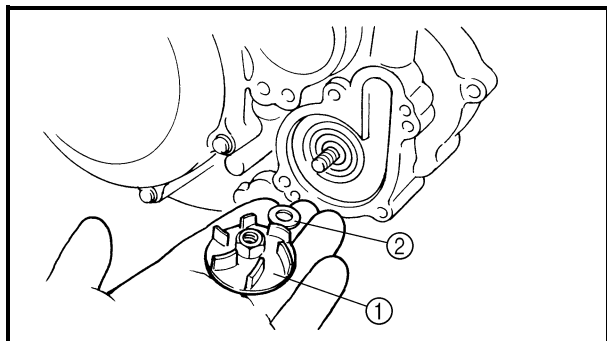

## REMOVAL POINTS

### Impeller shaft

1. Remove:
  - Impeller ①
  - Washer ②
  - Impeller shaft ③

### NOTE:

Hold the impeller shaft on its width across the flats ④ with spanners, etc. and remove the impeller.

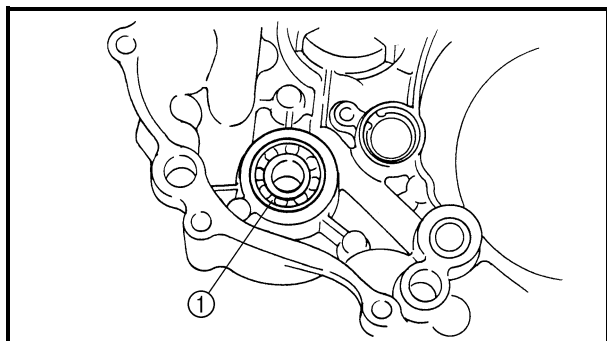
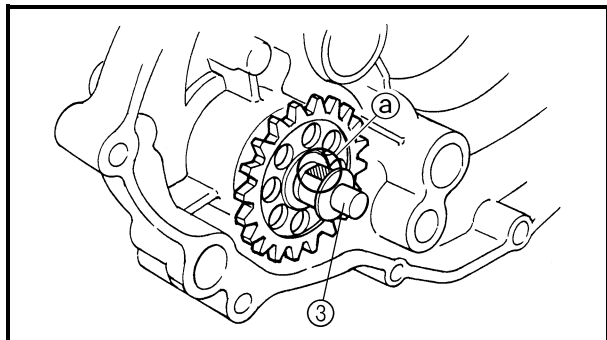

EC4G3210

### Oil seal

### NOTE:

It is not necessary to disassemble the water pump, unless there is an abnormality such as excessive change in coolant level, discoloration of coolant, or milky transmission oil.

1. Remove:
  - Bearing ①
2. Remove:
  - Oil seal ①

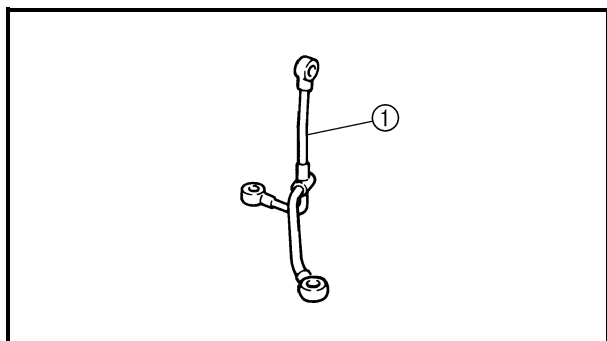
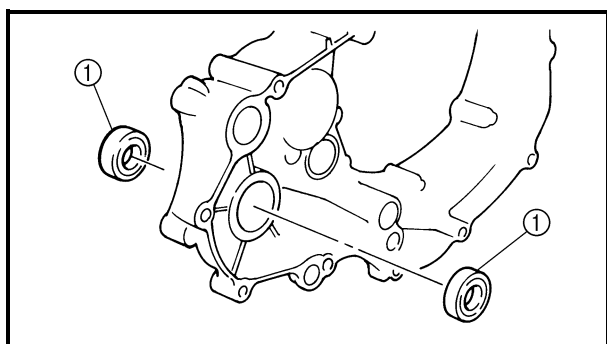

## INSPECTION

### Oil delivery pipe

1. Inspect:
  - Oil delivery pipe ①
  - Bend/damage → Replace.
  - Clogged → Blow.

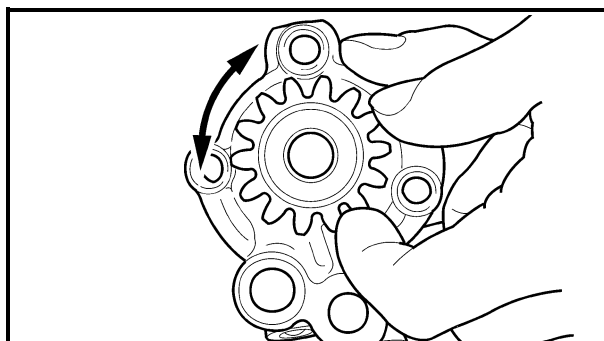
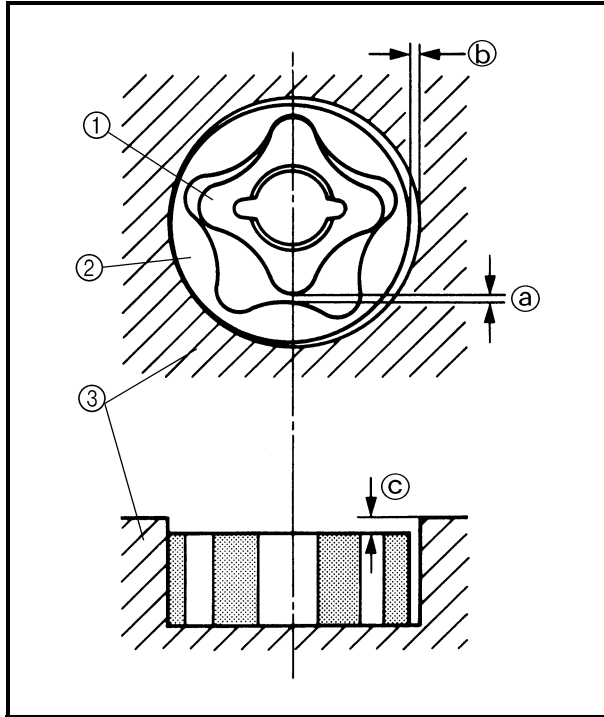
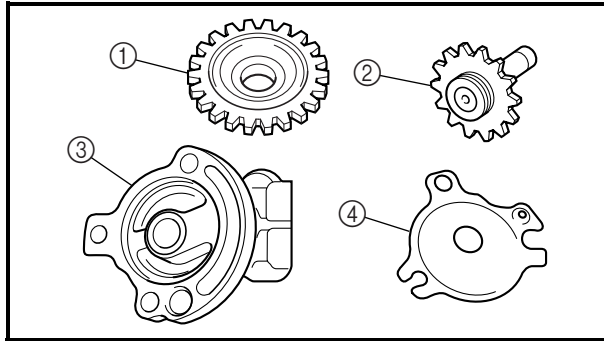

## INSPECTION

### Oil pump

#### 1. Inspect:

- Oil pump drive gear ①
  - Oil pump drive shaft ②
  - Rotor housing ③
  - Oil pump cover ④
- Cracks/wear/damage → Replace.

#### 2. Measure:

- Tip clearance ①  
(between the inner rotor ① and outer rotor ②)
  - Side clearance ②  
(between the outer rotor ② and rotor housing ③)
  - Housing and rotor clearance ③  
(between the rotor housing ③ and rotors ① ②)
- Out of specification → Replace the oil pump assembly.



#### Tip clearance ①:

**0.12 mm or less**  
**(0.0047 in or less)**

**<Limit>: 0.20 mm (0.008 in)**

#### Side clearance ②:

**0.09 ~ 0.17 mm**  
**(0.0035 ~ 0.0067 in)**

**<Limit>: 0.24 mm (0.009 in)**

#### Housing and rotor clearance ③:

**0.03 ~ 0.10 mm**  
**(0.0012 ~ 0.0039 in)**

**<Limit>: 0.17 mm (0.0067 in)**

#### 3. Check:

- Unsmooth → Repeat steps #1 and #2 or replace the defective parts.



## AC MAGNETO AND STARTER CLUTCH

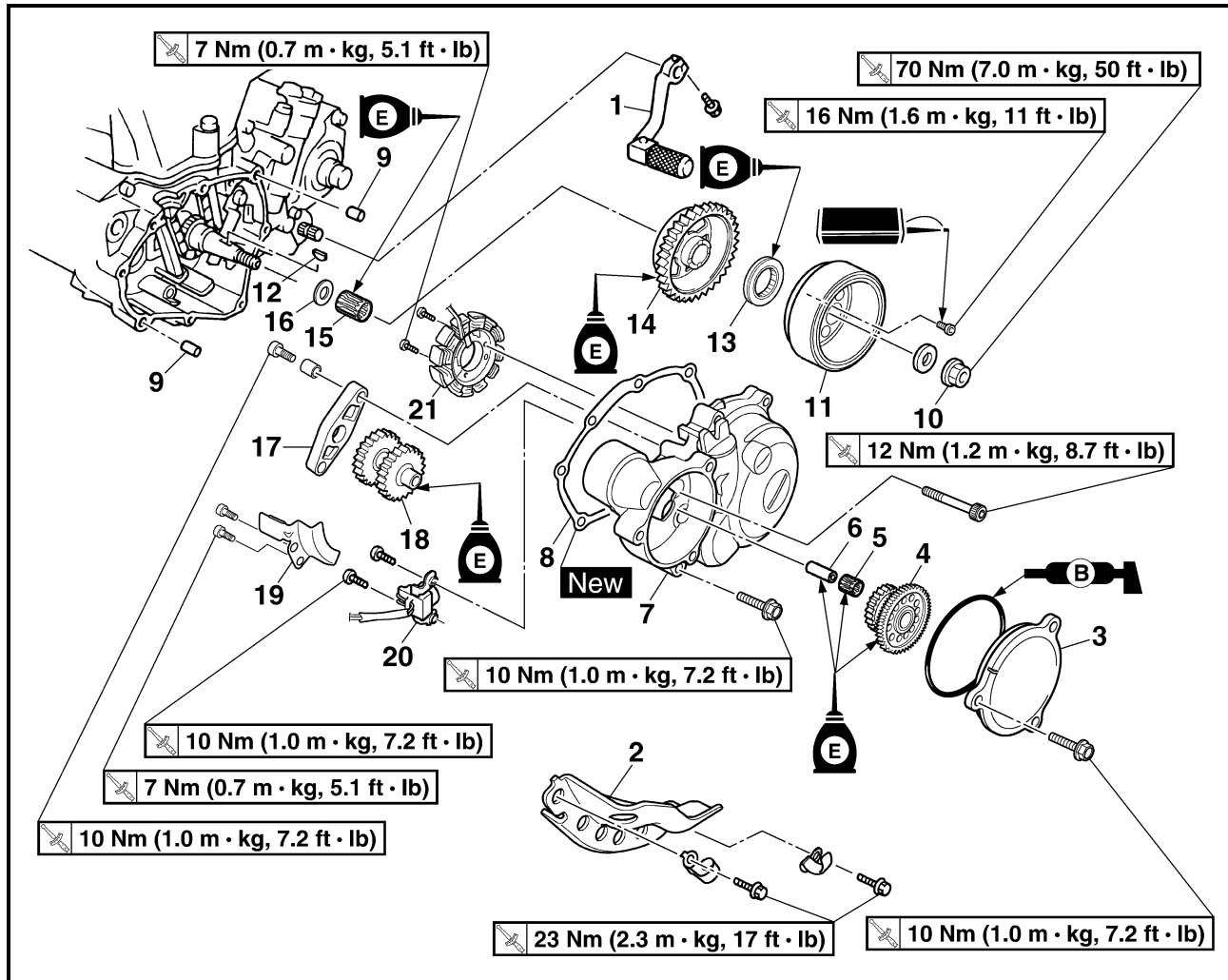

Extent of removal:

- ① Starter clutch/wheel gear removal
- ② Rotor removal
- ③ Pickup coil/stator removal

Extent of removal	Order	Part name	Q'ty	Remarks
Preparation for removal		<b>AC MAGNETO AND STATOR REMOVAL</b>		
		Drain the engine oil.		Refer to "ENGINE OIL REPLACEMENT" section in the CHAPTER 3.
		Seat and fuel tank		Refer to "SEAT, FUEL TANK AND SIDE COVERS" section.
		Bolt [radiator (left)] Disconnect the AC magneto lead.		Refer to "RADIATOR" section.
<div style="display: flex; justify-content: space-around;"> <div style="text-align: center;">             ↑ ① ↓           </div> <div style="text-align: center;">             ↑ ③ ↓           </div> </div>	1	Shift pedal	1	
	2	Engine guard (left)	1	
	3	Cover (idle gear 1)	1	
	4	Idle gear 1	1	
	5	Bearing	1	
	6	Shaft	1	
	7	Crankcase cover (left)	1	
	8	Gasket	1	
	9	Dowel pin	2	

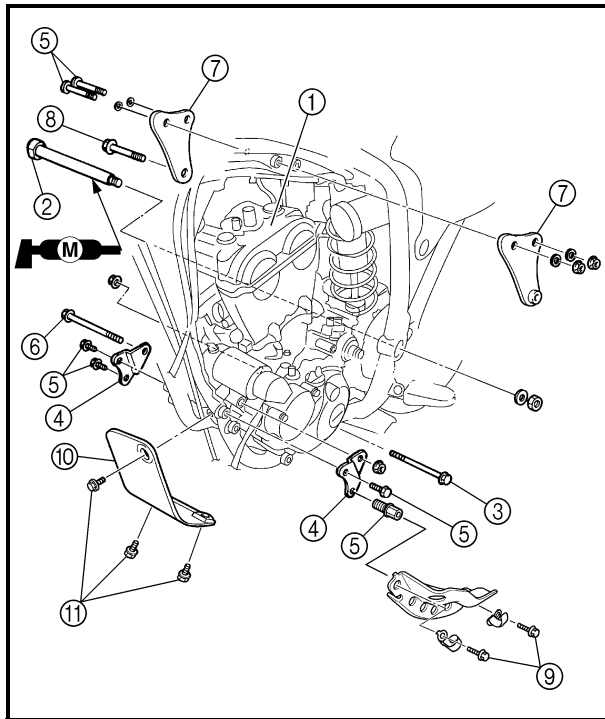

EC4M5000

**ASSEMBLY AND INSTALLATION****Engine installation**

## 1. Install:

- Engine ①  
Install the engine from right side.

- Pivot shaft ②

85 Nm (8.5 m · kg, 61 ft · lb)

- Engine mounting bolt (lower) ③

69 Nm (6.9 m · kg, 50 ft · lb)

- Lower engine bracket ④

- Bolt (engine bracket) ⑤

34 Nm (3.4 m · kg, 24 ft · lb)

- Engine mounting bolt (front) ⑥

69 Nm (6.9 m · kg, 50 ft · lb)

- Upper engine bracket ⑦

- Engine mounting bolt (upper) ⑧

55 Nm (5.5 m · kg, 40 ft · lb)

- Bolt (left engine guard) ⑨

23 Nm (2.3 m · kg, 17 ft · lb)

- Lower engine guard ⑩

- Bolt (lower engine guard) ⑪

10 Nm (1.0 m · kg, 7.2 ft · lb)

**NOTE:**

Apply the molybdenum disulfide grease on the pivot shaft.

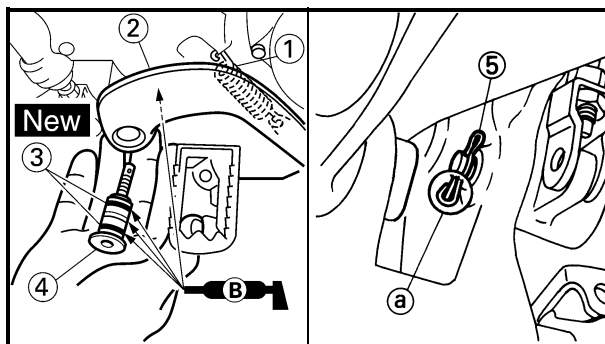

EC4M5211

**Brake pedal**

## 1. Install:

- Spring ①

- Brake pedal ②

- O-ring ③ **New**

- Bolt (brake pedal) ④

26 Nm (2.6 m · kg, 19 ft · lb)

- Clip ⑤

**NOTE:**

• Apply the lithium soap base grease on the bolt, O-rings and brake pedal bracket.

• Install the clip with its stopper portion ② facing inward.

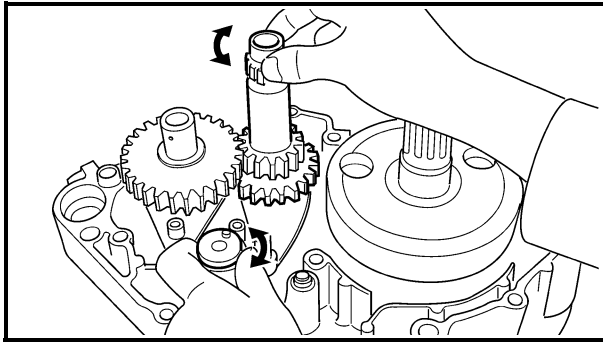

2. Check:
  - Shifter operation
  - Transmission operation
 Unsmooth operation → Repair.

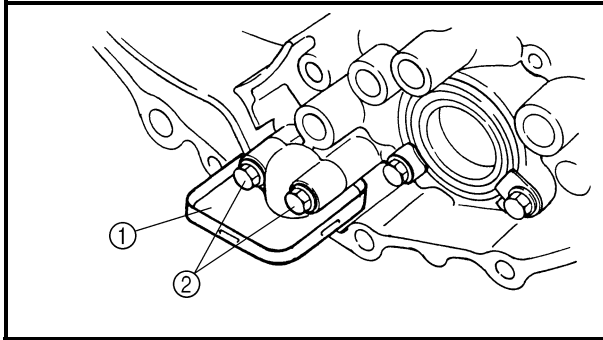

3. Install:
  - Oil strainer ①
  - Bolt (oil strainer) ②

 **10 Nm (1.0 m · kg, 7.2 ft · lb)**

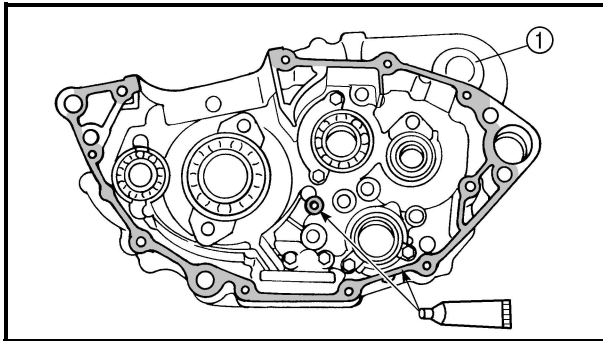

4. Apply:
  - Sealant
 On the right crankcase ①.



**Quick gasket®:**  
**ACC-QUICK-GS-KT**  
**YAMAHA Bond No. 1215:**  
**90890-85505**

**NOTE:** \_\_\_\_\_  
 Clean the contacting surface of left and right crankcase before applying the sealant.  
 \_\_\_\_\_

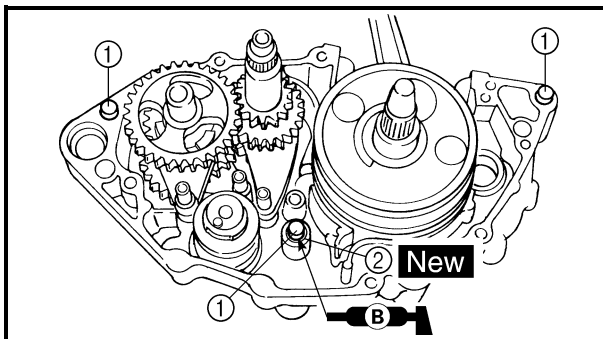

5. Install:
  - Dowel pin ①
  - O-ring ② **New**
  - Right crankcase
 To left crankcase.

**NOTE:** \_\_\_\_\_  
 • Fit the right crankcase onto the left crankcase. Tap lightly on the case with soft hammer.  
 • When installing the crankcase, the connecting rod should be positioned at TDC (top dead center).  
 \_\_\_\_\_

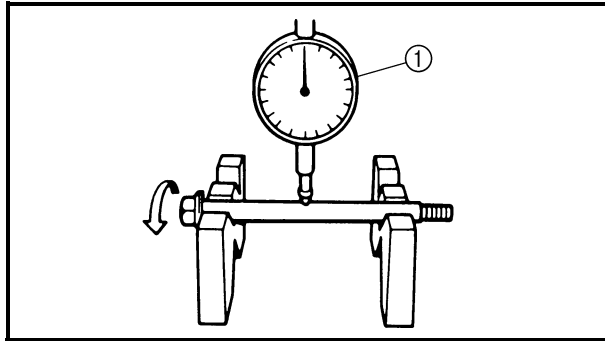

EC514200

### Wheel axle

1. Measure:
  - Wheel axle bends  
Out of specification → Replace.  
Use the dial gauge ①.



**Wheel axle bending limit:**  
**0.5 mm (0.020 in)**

### NOTE:

The bending value is shown by one half of the dial gauge reading.

### ⚠ WARNING

**Do not attempt to straighten a bent axle.**

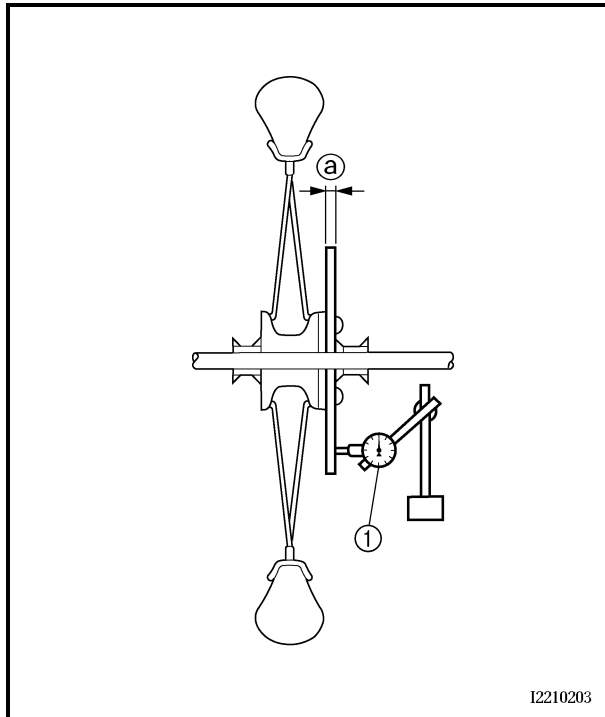

I2210203

EC594200

### Brake disc

1. Measure:
  - Brake disc deflection (only rear brake disc)  
Use the dial gauge ①.  
Out of specification → Inspect wheel runout.  
If wheel runout is in good condition, replace the brake disc.



**Brake disc deflection limit:**  
**Rear:**  
**<Limit>: 0.15 mm (0.006 in)**

2. Measure:

- Brake disc thickness ②  
Out of limit → Replace.



**Brake disc thickness:**  
**Front:**  
**3.0 mm (0.12 in)**  
**<Limit>: 2.5 mm (0.10 in)**  
**Rear:**  
**4.0 mm (0.16 in)**  
**<Limit>: 3.5 mm (0.14 in)**

## BRAKE MASTER CYLINDER DISASSEMBLY

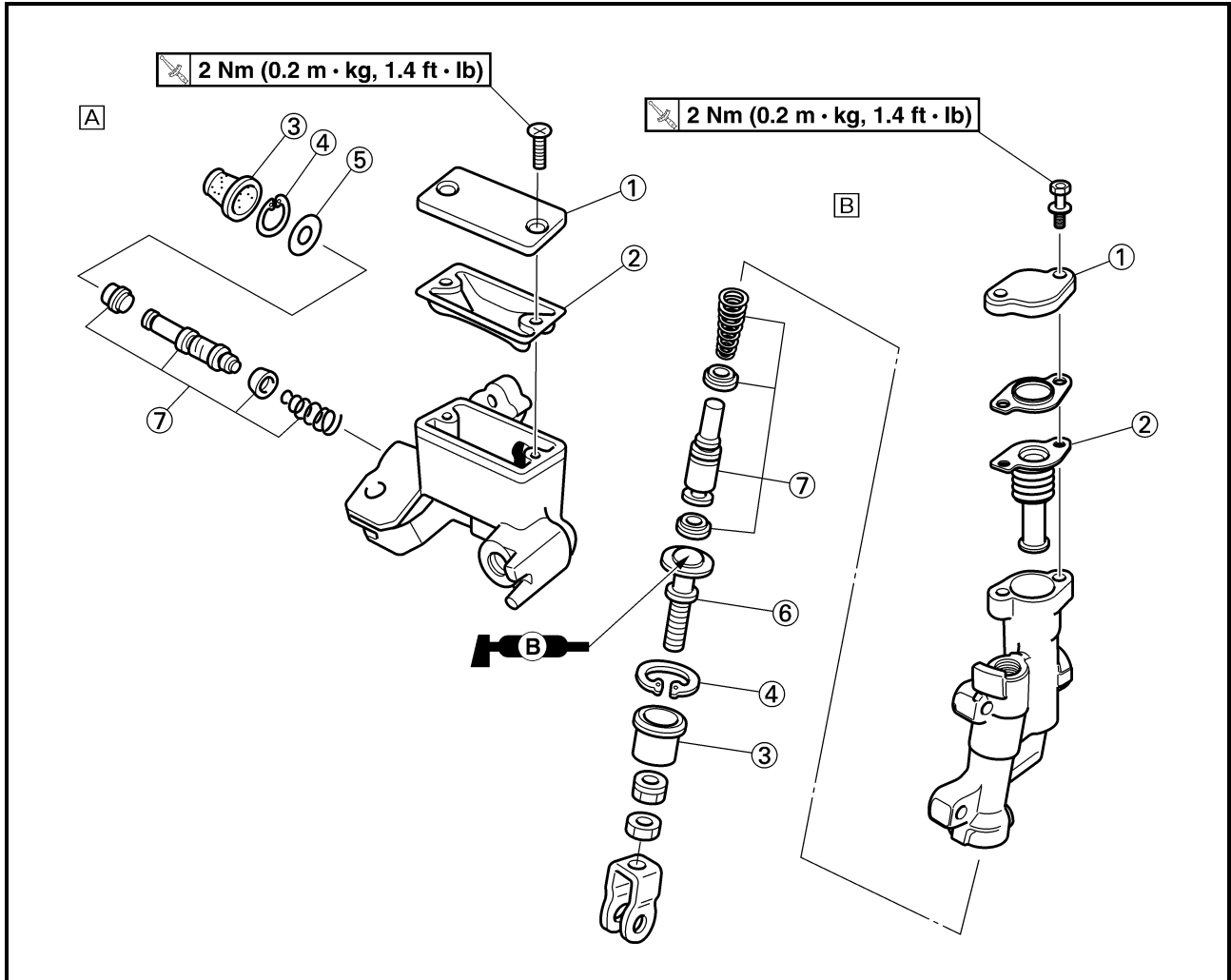

**A** Front

**B** Rear

Extent of removal:                    ① Front brake master cylinder disassembly    ② Rear brake master cylinder disassembly

Extent of removal	Order	Part name	Q'ty	Remarks
<b>BRAKE MASTER CYLINDER DISASSEMBLY</b>				
<div style="display: flex; justify-content: space-around;"> <div style="text-align: center;">             ↑ ① ↓           </div> <div style="text-align: center;">             ↑ ② ↓           </div> </div>	①	Brake master cylinder cap	1	Use a long nose circlip pliers.
	②	Diaphragm	1	
	③	Brake master cylinder boot	1	
	④	Circlip	1	
	⑤	Washer	1	
	⑥	Push rod	1	
	⑦	Brake master cylinder kit	1	

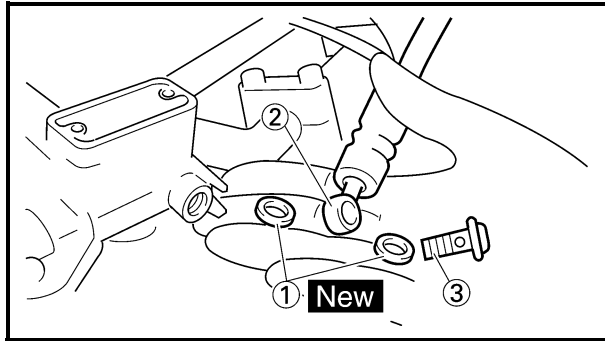

4. Install:

- Copper washer ① **New**
- Brake hose ②
- Union bolt ③

30 Nm (3.0 m · kg, 22 ft · lb)

**⚠ WARNING**

Always use new copper washers.

**CAUTION:**

Install the brake hose so that it contacts the brake master cylinder projection ① and that its bent portion ② faces downward.

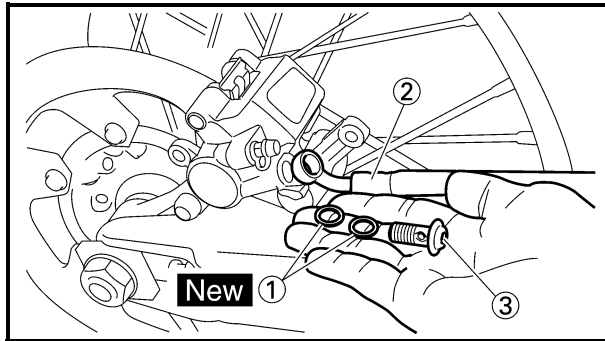
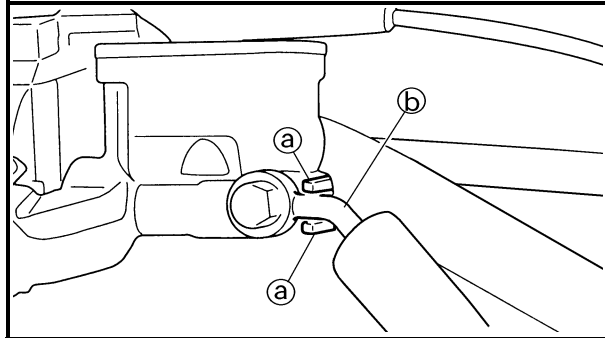

Rear brake hose

1. Install:

- Copper washer ① **New**
- Brake hose ②
- Union bolt ③

30 Nm (3.0 m · kg, 22 ft · lb)

**⚠ WARNING**

Always use new copper washers.

**CAUTION:**

Install the brake hose so that its pipe portion ① directs as shown and lightly touches the projection ② on the brake caliper.

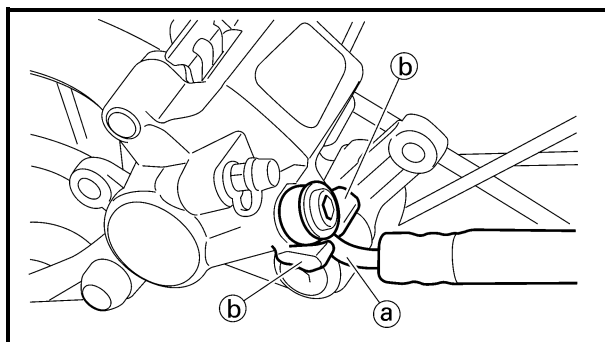

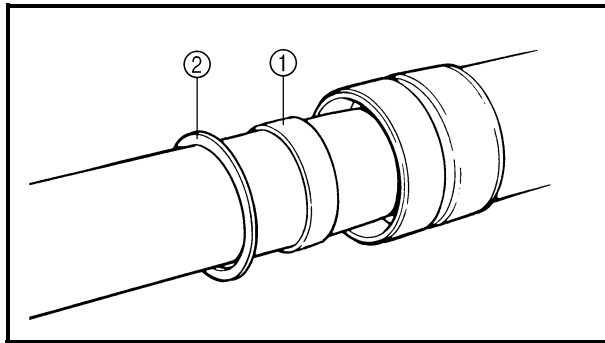

9. Install:
- Slide metal ①
  - Oil seal washer ②
- To outer tube slot.

**NOTE:** \_\_\_\_\_  
 Press the slide metal into the outer tube with fork seal driver ③.



**Fork seal driver:**  
 YM-01442/90890-01442

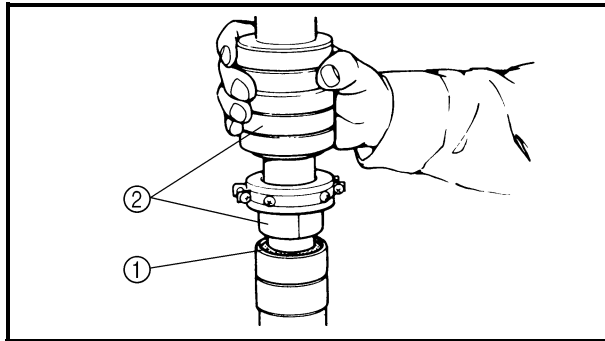
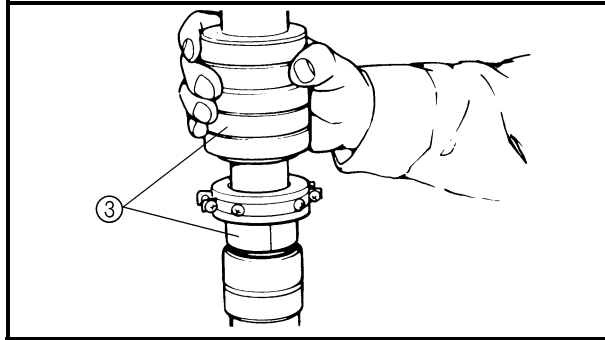

10. Install:
- Oil seal ①

**NOTE:** \_\_\_\_\_  
 Press the oil seal into the outer tube with fork seal driver ②.



**Fork seal driver:**  
 YM-01442/90890-01442

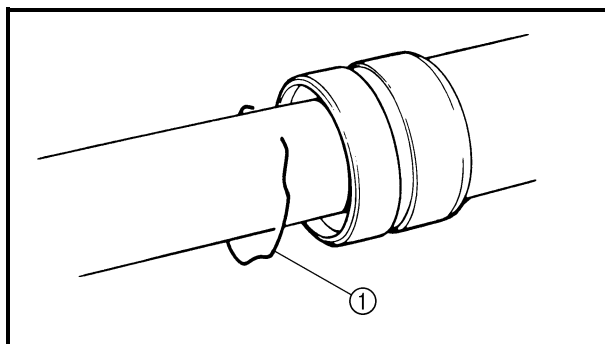

11. Install:
- Stopper ring ①

**NOTE:** \_\_\_\_\_  
 Fit the stopper ring correctly in the groove in the outer tube.

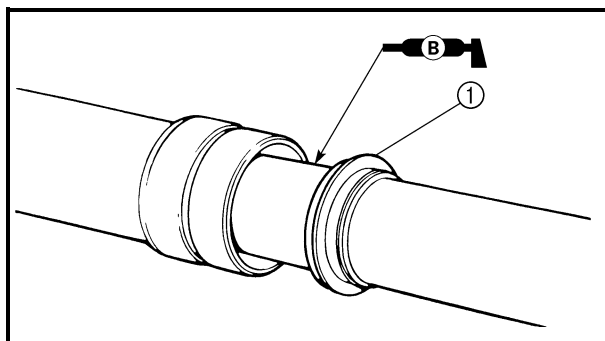

12. Install:
- Dust seal ①

**NOTE:** \_\_\_\_\_  
 Apply the lithium soap base grease on the inner tube.

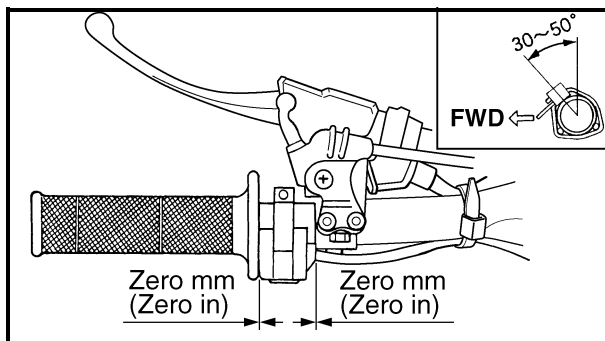
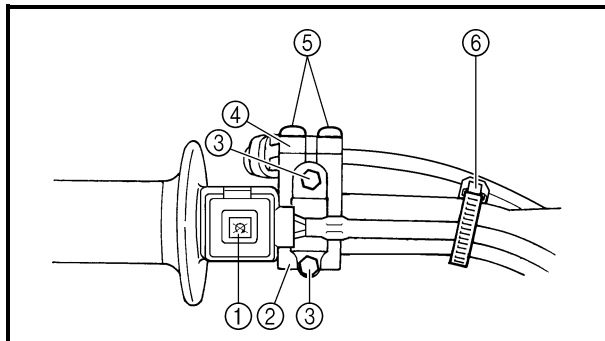
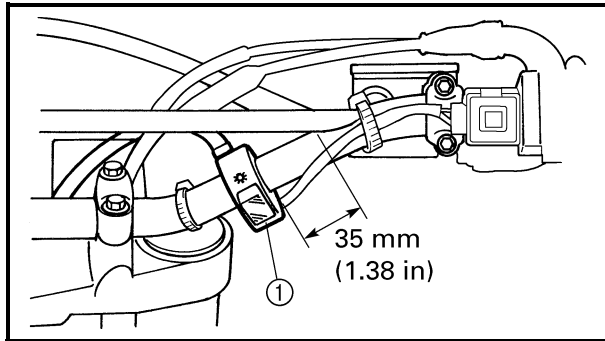
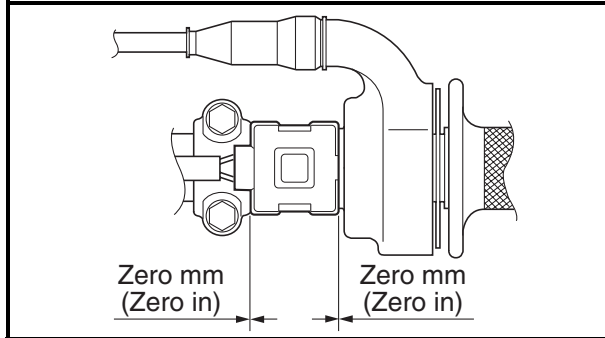
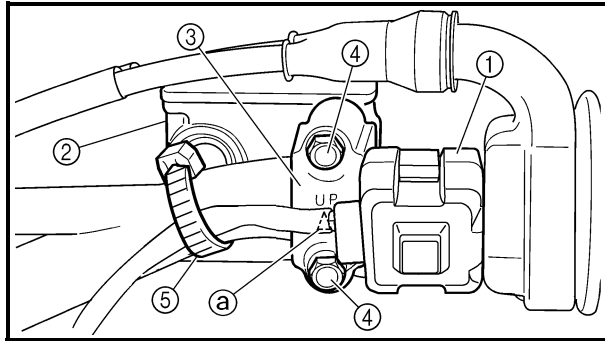

## 8. Install:

- Start switch ①
  - Brake master cylinder ②
  - Brake master cylinder bracket ③
  - Bolt (brake master cylinder bracket) ④
- 9 Nm (0.9 m · kg, 6.5 ft · lb)**
- Clamp ⑤

**NOTE:**

- The start switch and brake master cylinder bracket should be installed according to the dimensions shown.
- Install the bracket so that the arrow mark (a) faces upward.
- First tighten the bolt on the upper side of the brake master cylinder bracket, and then tighten the bolt on the lower side.

## 9. Install:

- Light switch ①

**2 Nm (0.2 m · kg, 1.4 ft · lb)**

## 10. Install:

- Engine stop switch ①
- Clutch lever holder ②
- Bolt (clutch lever holder) ③

**4 Nm (0.4 m · kg, 2.9 ft · lb)**

- Hot starter lever holder ④
- Bolt (hot starter lever holder) ⑤

**4 Nm (0.4 m · kg, 2.9 ft · lb)**

- Clamp ⑥

**NOTE:**

- The engine stop switch, clutch lever holder and clamp should be installed according to the dimensions shown.
- Pass the engine stop switch lead in the middle of the clutch lever holder.



EC578000

SWINGARM DISASSEMBLY

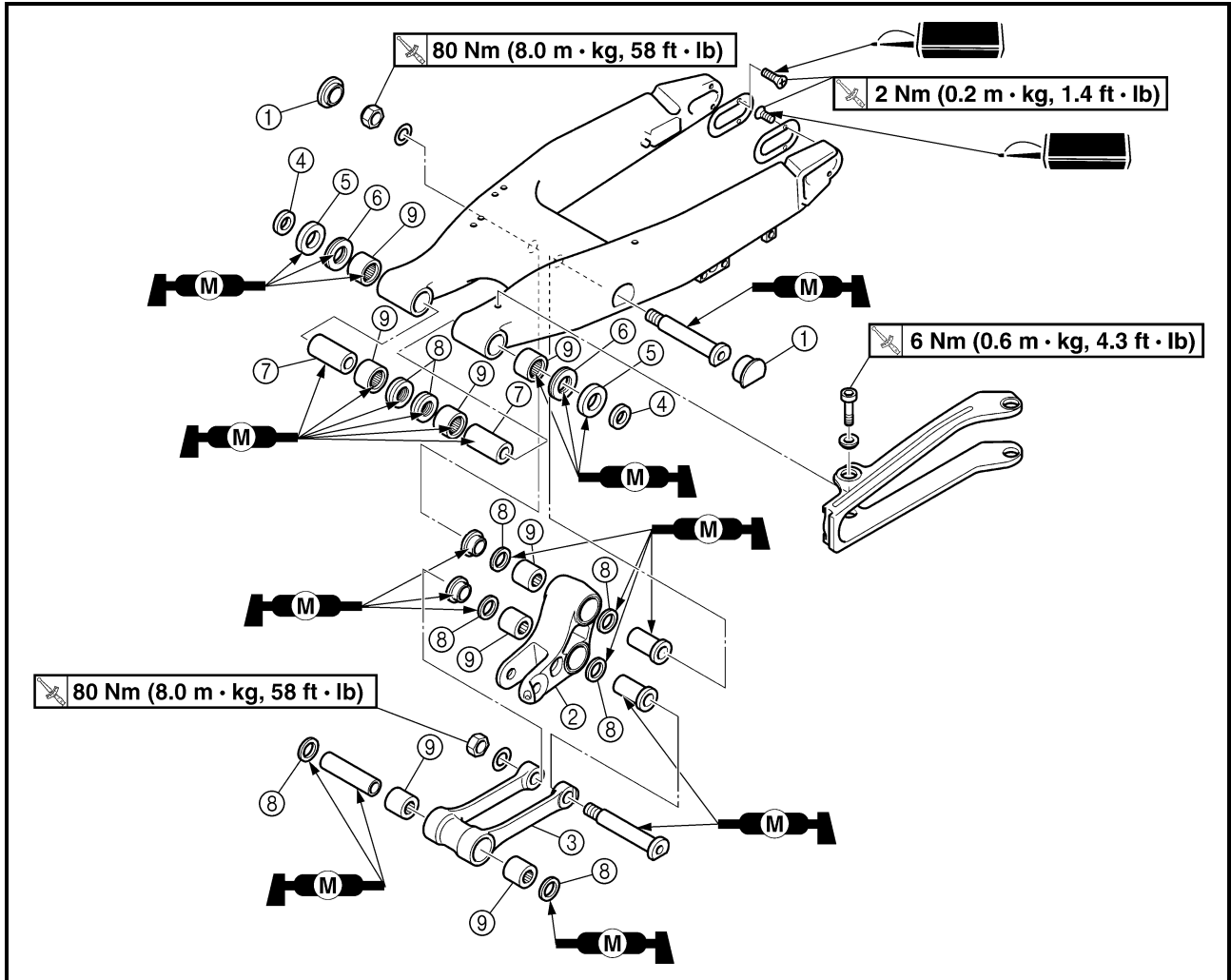

Extent of removal:

- ① Swingarm disassembly
- ② Connecting rod removal and disassembly
- ③ Relay arm removal and disassembly

Extent of removal	Order	Part name	Q'ty	Remarks
		<b>SWINGARM DISASSEMBLY</b>		
↑ ③ ↓	①	Cap	2	Refer to "REMOVAL POINTS".
↑ ② ↓	②	Relay arm	1	
↑ ③ ↓	③	Connecting rod	1	
↑ ④ ↓	④	Collar	2	
↑ ⑤ ↓	⑤	Oil seal	2	
↑ ⑥ ↓	⑥	Thrust bearing	2	
↑ ⑦ ↓	⑦	Bushing	2	
↑ ⑧ ↓	⑧	Oil seal	8	
↑ ⑨ ↓	⑨	Bearing	8	

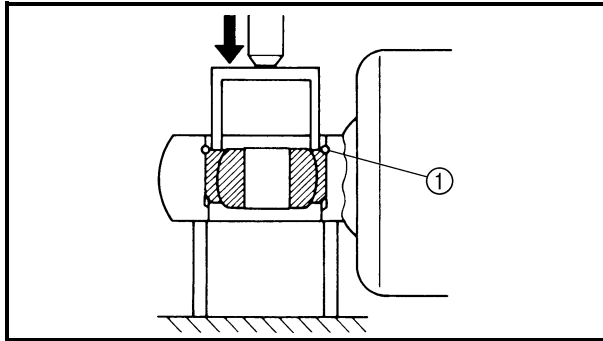

EC583000

## REMOVAL POINTS

EC583320

### Bearing

- Remove:
  - Stopper ring (upper bearing) ①

#### NOTE:

Press in the bearing while pressing its outer race and remove the stopper ring.

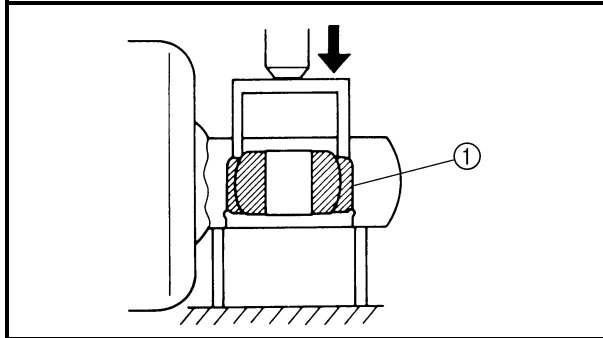

- Remove:
  - Upper bearing ①

#### NOTE:

Remove the bearing by pressing its outer race.

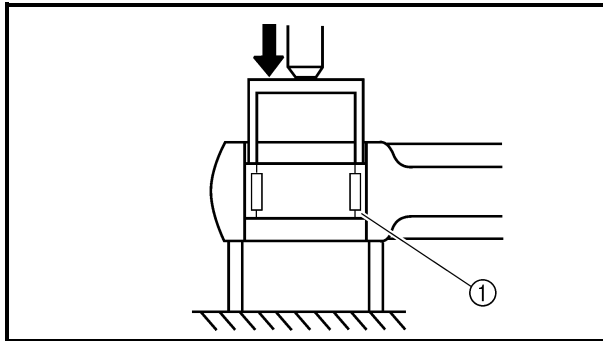

- Remove:
  - Lower bearing ①

#### NOTE:

Remove the bearing by pressing its outer race.

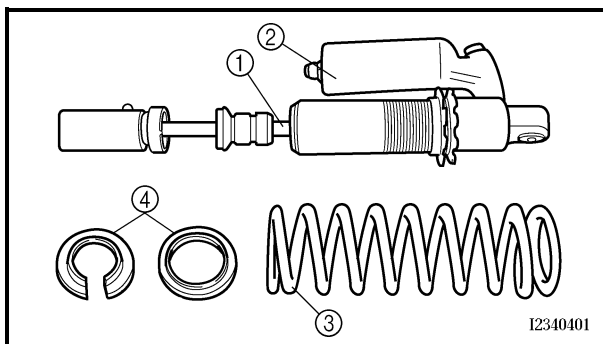

EC584000

## INSPECTION

### Rear shock absorber

- Inspect:
  - Damper rod ①  
Bends/damage → Replace rear shock absorber assembly.
  - Shock absorber ②  
Oil leaks → Replace rear shock absorber assembly.  
Gas leaks → Replace rear shock absorber assembly.
  - Spring ③  
Damage → Replace spring.  
Fatigue → Replace spring.  
Move spring up and down.
  - Spring guide ④  
Wear/damage → Replace spring guide.
  - Bearing ⑤  
Free play exists/unsmooth revolution/rust → Replace.

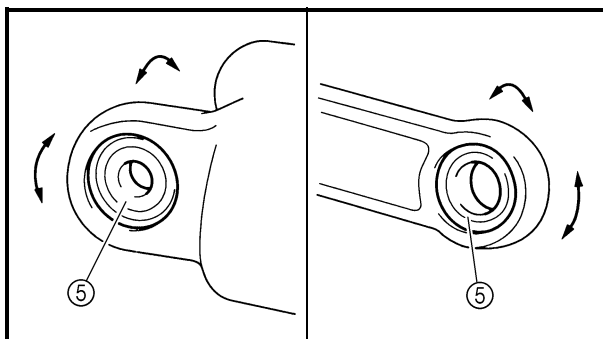

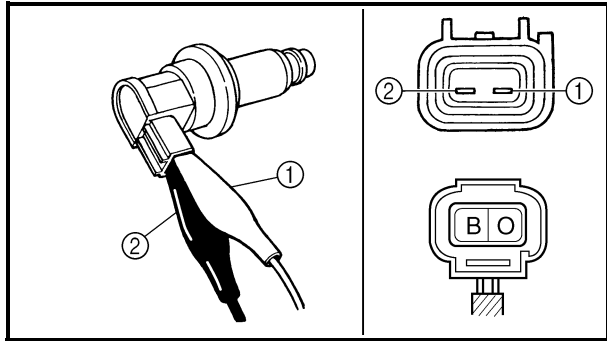
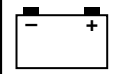

EC626002

**IGNITION COIL INSPECTION**

1. Remove the ignition coil cap.
2. Inspect:
  - Primary coil resistance
 Out of specification → Replace.

Tester (+) lead → Orange lead ①  
 Tester (-) lead → Black lead ②

	<b>Primary coil resistance</b>	<b>Tester selector position</b>
	<b>0.08 ~ 0.10 Ω at 20 °C (68 °F)</b>	<b>Ω × 1</b>

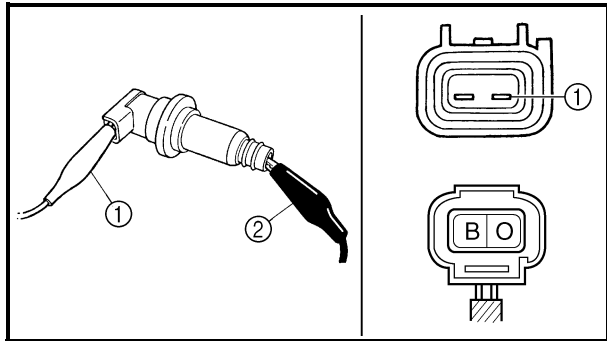

3. Inspect:
  - Secondary coil resistance
 Out of specification → Replace.

Tester (+) lead → Orange lead ①  
 Tester (-) lead → Spark plug terminal ②

	<b>Secondary coil resistance</b>	<b>Tester selector position</b>
	<b>4.6 ~ 6.8 kΩ at 20 °C (68 °F)</b>	<b>kΩ × 1</b>

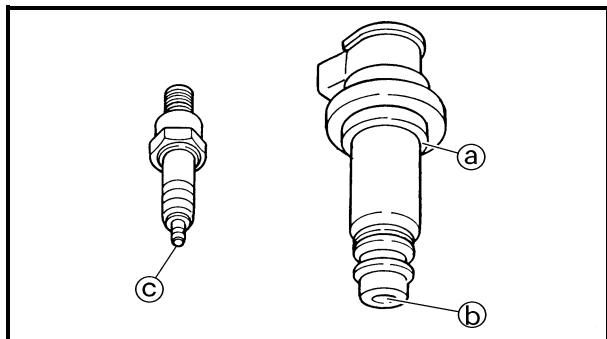

4. Inspect:
  - Sealed portion of ignition coil (a)
  - Spark plug terminal pin (b)
  - Threaded portion of spark plug (c)
 Wear → Replace.

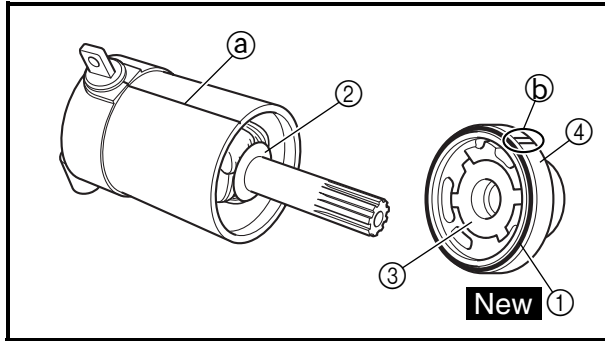
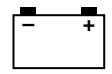

## 4. Install:

- Gasket ① **New**
- Circlip ④
- Plain washer ②
- Washer (starter motor front cover) ③
- Starter motor front cover ④

**NOTE:** \_\_\_\_\_

- For installation, align the projections on the washer with the slots in the front cover.
- Align the match mark **a** on the starter motor yoke with the match mark **b** on the starter motor front cover.

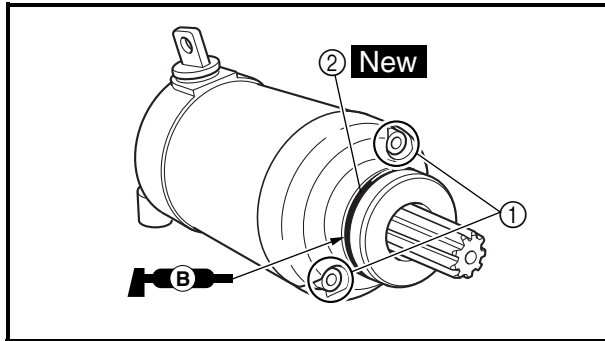

## 5. Install:

- Gasket
- Bolt ①
- O-ring ② **New**

**NOTE:** \_\_\_\_\_

- Apply the lithium soap base grease on the O-ring.



EC700000

## TUNING

EC710000

### ENGINE

#### Carburetor setting

- The air/fuel mixture will vary depending on atmospheric conditions. Therefore, it is necessary to take into consideration the air pressure, ambient temperature, humidity, etc., when adjusting the carburetor.
- Perform a test run to check for proper engine performance (e.g., throttle response) and spark plug(-s) discoloration or fouling. Use these readings to determine the best possible carburetor setting.

#### NOTE:

It is recommended to keep a record of all carburetor settings and external conditions (e.g., atmospheric conditions, track/surface conditions, lap times) to make future carburetor setting easier.

#### **⚠ WARNING**

- **The carburetor is a part of the fuel line. Therefore, be sure to install it in a well-ventilated area, away from flammable objects and any sources of fire.**
- **Never look into the carburetor intake. Flames may shoot out from the pipe if the engine backfires while it is being started. Gasoline may be discharged from the accelerator pump nozzle when the carburetor has been removed.**



EC720000

## CHASSIS

### Selection of the secondary reduction ratio (Sprocket)

$$\text{Secondary reduction ratio} = \frac{\text{Number of rear wheel sprocket teeth}}{\text{Number of drive sprocket teeth}}$$

<b>Standard secondary reduction ratio</b>	<b>52/13 (4.000)</b>
---	----------------------

<Requirement for selection of secondary gear reduction ratio>

- It is generally said that the secondary gear ratio should be reduced for a longer straight portion of a speed course and should be increased for a course with many corners. Actually, however, as the speed depends on the ground condition of the day of the race, be sure to run through the circuit to set the machine suitable for the entire course.
- In actuality, it is very difficult to achieve settings suitable for the entire course and some settings may be sacrificed. Thus, the settings should be matched to the portion of the course that has the greatest effect on the race result. In such a case, run through the entire course while making notes of lap times to find the best balance; then, determine the secondary reduction ratio.
- If a course has a long straight portion where a machine can run at maximum speed, the machine is generally set such that it can develop its maximum revolutions toward the end of the straight line, with care taken to avoid the engine over-revving.

#### **NOTE:**

Riding technique varies from rider to rider and the performance of a machine also vary from machine to machine. Therefore, do not imitate other rider's settings from the beginning but choose your own setting according to the level of your riding technique.

CLICK HERE TO **DOWNLOAD** THE COMPLETE MANUAL

- Thank you very much for reading the preview of the manual.
- You can download the complete manual from: [www.heydownloads.com](http://www.heydownloads.com) by clicking the link below



- Please note: If there is no response to CLICKING the link, please download this PDF first and then click on it.

CLICK HERE TO **DOWNLOAD** THE COMPLETE MANUAL