

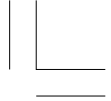

08/04/22 10:24:48 32HN8660 0001



This manual should be considered a permanent part of the ATV and should remain with the ATV when it is resold.

This publication includes the latest production information available before printing. Honda Motor Co., Ltd. reserves the right to make changes at any time without notice and without incurring any obligation.

No part of this publication may be reproduced without written permission.

© Honda Motor Co., Ltd. 2008

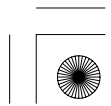

CLICK HERE TO **DOWNLOAD** THE COMPLETE MANUAL

- Thank you very much for reading the preview of the manual.
- You can download the complete manual from: [www.heydownloads.com](http://www.heydownloads.com) by clicking the link below



- Please note: If there is no response to CLICKING the link, please download this PDF first and then click on it.

CLICK HERE TO **DOWNLOAD** THE COMPLETE MANUAL



## Important Safety Information

---

Your ATV can provide many years of service and pleasure if you take responsibility for your own safety and understand the challenges you can meet while riding.

There is much that you can do to protect yourself when you ride. You'll find many helpful recommendations throughout this manual. The following are a few that we consider to be most important.

### **Follow the Age Recommendation**

The minimum recommended age for this ATV model is 16. Children under age 16 should never operate this vehicle.

### **Always Wear a Helmet**

It's a proven fact: helmets significantly reduce the number and severity of head injuries. So always wear an approved motorcycle helmet. We also recommend that you wear eye protection, sturdy boots, gloves, and other protective gear (page 44 ).

### **Never Carry a Passenger**

Your ATV is designed for one person only. There are no handholds, footrests, or seat for a second person, so never carry a passenger. A passenger could interfere with your ability to move around to maintain your balance and control of the ATV.

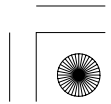
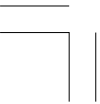



## Operation Component Locations

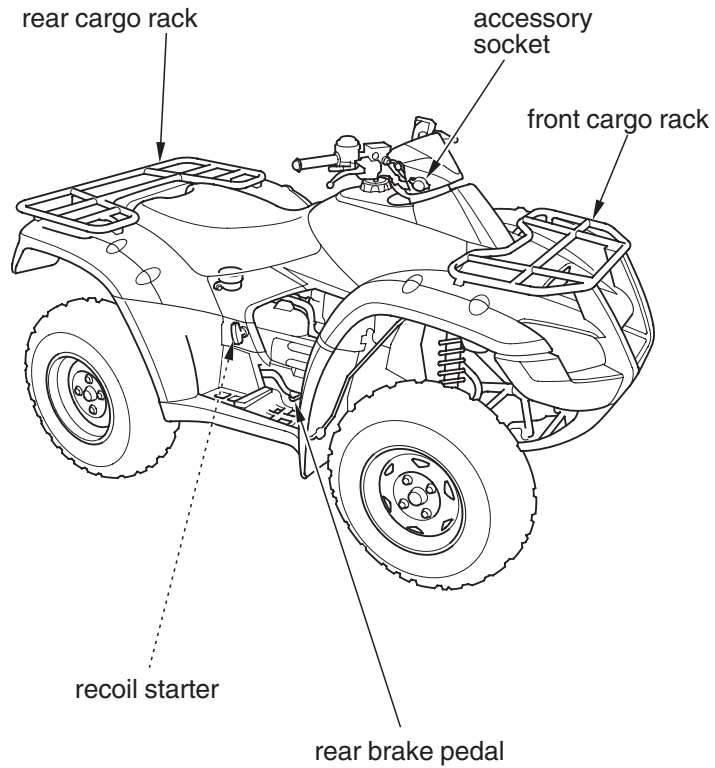

### 12 Instruments & Controls

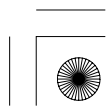
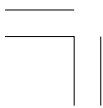



## Indicators & Displays

### Odometer/Tripmeter

The odometer/tripmeter display has two functions, odometer (1) and tripmeter.

The tripmeter has two sub modes, tripmeter A (2) and tripmeter B (3).

The odometer registers total distance traveled in kilometers while the ignition switch is ON (1).

The tripmeter shows mileage per trip while the ignition is ON (1).

To change the display from tripmeter A or tripmeter B to odometer, press and release the odometer/tripmeter select button (4).

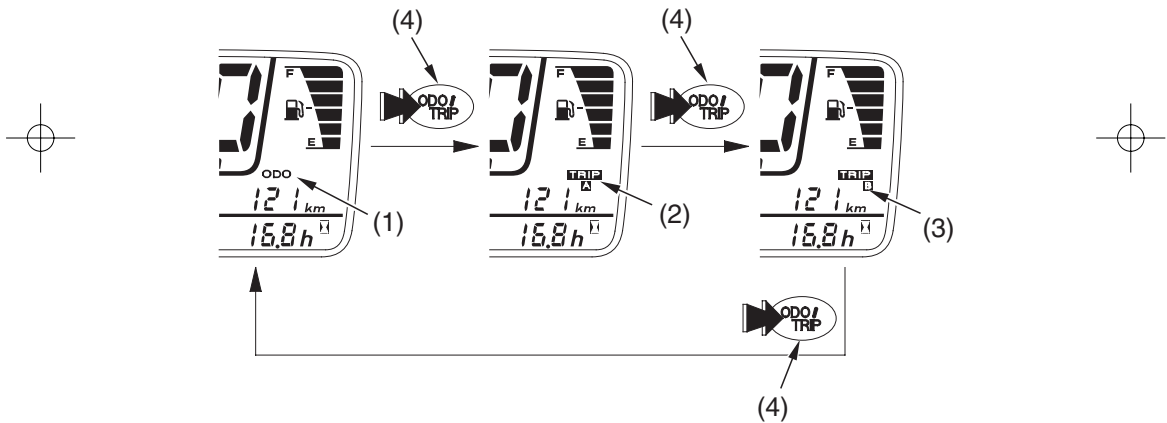

(1) odometer  
(2) tripmeter A

(3) tripmeter B  
(4) odometer/tripmeter  
select button

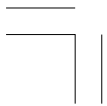



# Controls & Features

## Headlight Switch



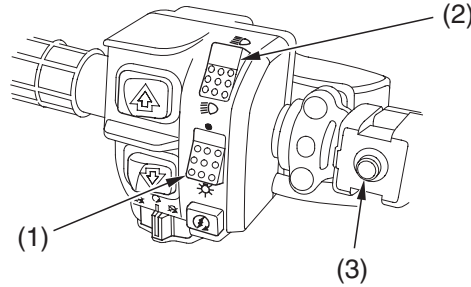

LEFT HANDLEBAR







(1) headlight switch



(2) headlight dimmer switch

(3) horn button

-  ON
-  OFF
-  HI
-  LO

The headlight switch (1) is used to turn the headlight ON (  ) or OFF (  ). To operate, turn the switch to ON (  ) or OFF (  ).

## Headlight Dimmer Switch

The headlight dimmer switch (2) is used to change between the high and low beams of the headlight. To operate, turn the switch to HI (  ) for high beam, LO (  ) for low beam.

## Horn Button

Press the horn button (3) to sound the horn.

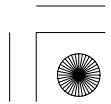
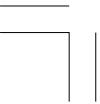



08/04/22 10:30:22 32HN8660 0051



## 42 Instruments & Controls

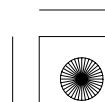
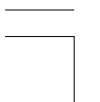



## Is Your ATV Ready to Ride?

---

*Headlight and  
Headlight Dimmer  
Switch*

Check for proper function (page 32 ).

*Engine Stop Switch*

Check for proper function (page 31 ).

*Steering*

Check that the wheels turn properly as you steer the handlebar. Move the handlebar right and left and check that there is no excessive backlash.

Remember, be sure to take care of any problem you find, or have your Honda dealer correct it before you ride.

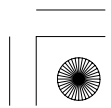
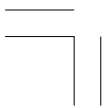



## Safe Riding Precautions

---

You should never ride your ATV on public streets, roads or highways, even if they are not paved. Drivers of street vehicles may have difficulty seeing and avoiding you, which could lead to a collision. In many states it is illegal to operate ATVs on public streets, roads and highways.

### **WARNING**

Operating this ATV on public streets, roads or highways could cause you to collide with another vehicle.

Never operate this ATV on any public street, road or highway, even a dirt or gravel one.



### **Keep Hands and Feet on Controls**



Always keep both hands on the handlebars and both feet on the footpegs when riding your ATV. This is important to maintain your balance and to control the vehicle. Removing even one hand from the handlebars or one foot from the footpegs can reduce your ability to control the ATV or could cause you to lose your balance and fall off the ATV.

### **WARNING**

Removing hands from handlebars or feet from footpegs during operation can reduce your ability to control the ATV or could cause you to lose your balance and fall off of the ATV.

Always keep both hands on the handlebars and both feet on the footpegs of your ATV during operation.

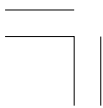



## Shifting Gears

---

The shift lever ( 1 ) is located on the left side of the fuel tank.  
To shift the shift lever, bring the ATV to a complete stop.

### NOTICE

*If the gearshift lever is moved while the vehicle is moving, the transmission may be damaged.*

The drive mode select switch ( 2 ) is located on the right handlebar switches.  
To select the drive mode, operate the drive mode select switch.  
With the throttle fully closed, the drive mode can be changed during running.

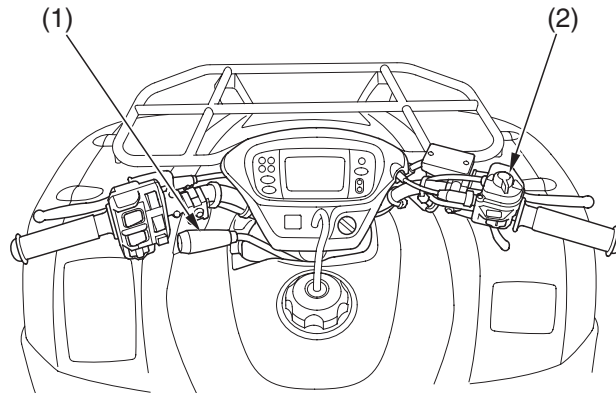

(1) shift lever

(2) drive mode select switch

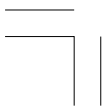



## Riding Your ATV

---

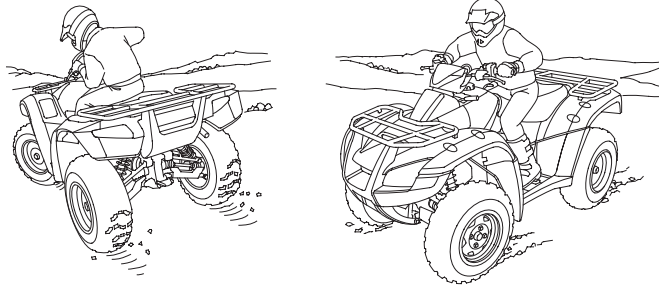

Lean your body to the inside of a turn and forward.

To make a turn on level ground: Steer the handlebar and lean your body toward the inside of the turn. Leaning helps balance the vehicle, and it feels more comfortable. Leaning into a turn is an important technique to master in riding an ATV.

To make a sharp turn at low speed: It helps to shift your body slightly forward on the seat, and lean inside, as you steer the handlebar. Shifting weight forward allows the rear wheels to turn easier, and it also improves front-wheel steering.

To make a turn from a full stop: Apply the throttle gradually when you turn and start up at the same time. Remember to shift your body forward to make sharp low-speed turns and whenever you turn while accelerating from a full stop.



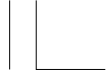

## Riding Your ATV

---

### Riding Through Water

Your ATV is designed to travel through water up to approximately 254 mm (10 inches) deep. Before crossing a stream, make sure the water is not too deep or flowing too fast.

#### **WARNING**

The ATV tyres have some ability to float. Operating this ATV through deep or fast-flowing water may cause a loss of traction and loss of control, which could lead to an accident.

Never operate this ATV in fast-flowing water or in water deeper than that specified in this owner's manual.



1. Choose a path where both banks have gradual slopes.
2. Proceed through the water at a slow, steady speed.
3. Watch out for submerged obstacles and slippery rocks.
4. Avoid getting the spark plug or air cleaner wet, as this would cause the engine to stop.
5. After leaving the water, always test both the front and rear brakes.
  - Riding through water can make the brakes less effective than normal, and may reduce stopping ability.
  - If necessary, apply the brakes repeatedly until they dry out and operate normally.

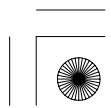
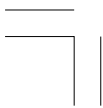



# Maintenance Schedule

Maintenance Procedures:

I: inspect and clean, adjust, lubricate, or replace, if necessary

C: clean

A: adjust

L: lubricate

R: replace

ITEMS	FREQUENCY	WHICHEVER COMES FIRST ⇒ NOTE	INITIAL MAINT.			REGULAR MAINT. INTERVAL		Refer to page
			km	150	1000	2000		
			mi	100	600	1200		
			HOURS	20	100	200		
* FUEL LINE					I		—	
* THROTTLE OPERATION					I		136	
AIR CLEANER		NOTE 1			C	C	131	
AIR CLEANER HOUSING DRAIN TUBE		NOTE 2			I	I	135	
SPARK PLUG					I		138	
* VALVE CLEARANCE				I	I	I	141	
ENGINE OIL			INITIAL= 150 km (100 mi), 20 operating hours or 1 month: R REGULAR= Every 1,000 km (600 mi), 100 operating hours or 12 months: R				114	
ENGINE OIL FILTER			R	R	R		119	
RADIATOR COOLANT		NOTE 3			I	I	126	
* COOLING SYSTEM		NOTE 2			I	I	—	

\* Should be serviced by your Honda dealer, unless you have the proper tools and service data, and are mechanically qualified. Refer to the official Honda Shop Manual.

## 102 Servicing Your Honda



CLICK HERE TO **DOWNLOAD** THE COMPLETE MANUAL

- Thank you very much for reading the preview of the manual.
- You can download the complete manual from: [www.heydownloads.com](http://www.heydownloads.com) by clicking the link below



- Please note: If there is no response to CLICKING the link, please download this PDF first and then click on it.

CLICK HERE TO **DOWNLOAD** THE COMPLETE MANUAL



# Fuel

## Fuel Capacity

Fuel tank capacity:

16.8 l (4.44 US gal , 3.70 Imp gal)

The tank should be refilled as soon as possible when the E segment in the fuel gauge flashes.

## Refueling Procedure

Refer to *Safety Precautions* on page 99.

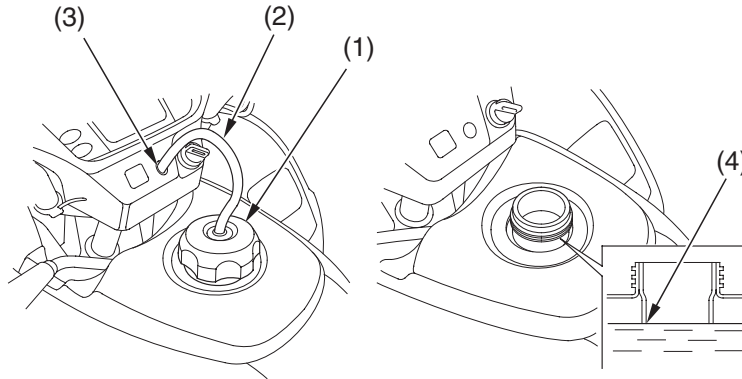

- (1) fuel fill cap
- (2) breather tube

- (3) handlebar cover hole
- (4) filler neck

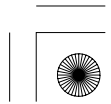



## Gear Case Oil

---

### Oil Recommendation

type	hypoid gear oil
viscosity (weight)	SAE 80
suggested oil	Honda shaft drive oil or equivalent

### Changing Oil

Refer to *Safety Precautions* on page 99.

Change the oil with the gear case at normal operating temperature to assure complete and rapid draining.

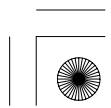
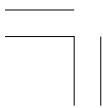



# Air Cleaner

## Cleaning

1. Remove the seat by pulling the seat latch (1) up.

UNDER SEAT

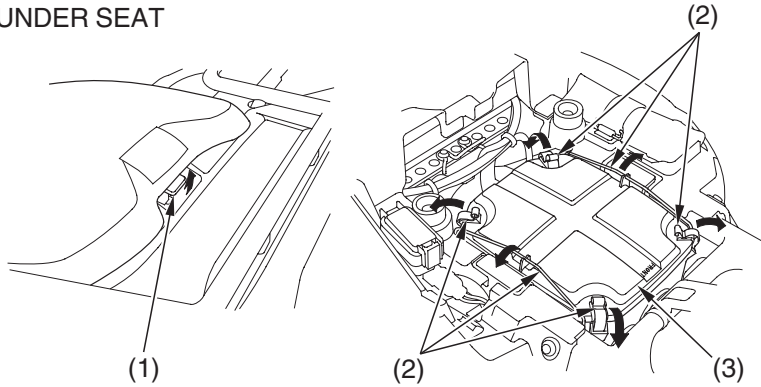

(1) seat latch  
(2) retainer clips

(3) air cleaner housing cover

2. Unlatch the retainer clips (2).
3. Remove the air cleaner housing cover (3).

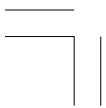



## Spark Arrester

---

Refer to *Safety Precautions* on page 99 .

The exhaust system must be periodically purged of accumulated carbon.  
To purge the system:

1. Allow the engine and muffler to cool.
2. Remove the bolts ( 1 ), the spark arrester ( 2 ) and the gasket ( 3 ) from the muffler ( 4 ).

REAR

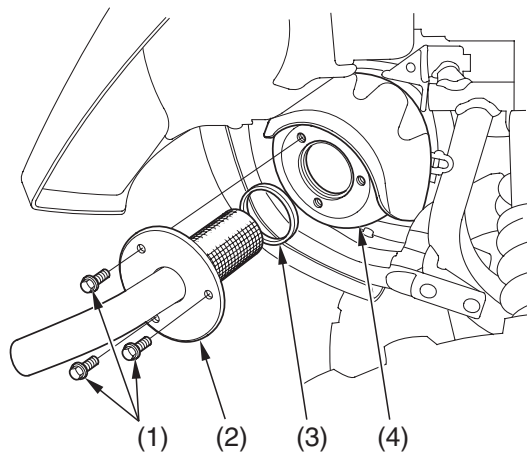

(1) bolts  
(2) spark arrester

(3) gasket  
(4) muffler



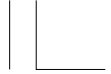

## Tyres

---

To safely operate your ATV, your tyres must be the proper type and size, in good condition with adequate tread, and correctly inflated.

### **WARNING**

Using tyres that are excessively worn or improperly inflated can cause a crash in which you can be seriously hurt or killed.

Follow all instructions in this owner's manual regarding tyre inflation and maintenance.

This ATV is equipped with low pressure tubeless tyres. Although the tyres are designed specifically for off-road use, they are not immune to punctures. Always select your riding area with care.

The following pages give detailed information on how and when to check your air pressure, how to inspect your tyres for wear and damage, and our recommendations for tyre repair and replacement.

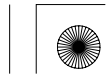



# Battery

---

## Battery Storage

Refer to *Safety Precautions* on page 99 .

If you plan to store your ATV, we recommend you remove the battery and store it where it can be charged at least every 30 days to maintain its service life.

If you do not remove the battery, we recommend disconnecting the battery cables (negative cable first).

You will get the best storage results from removing the battery and slow (trickle) charging it every 30 days (see *Battery Charging*, page 165 ).

Before you remove the battery, be sure to read all the information that follows, as well as the information on the battery label.



### **WARNING**

The battery gives off explosive hydrogen gas during normal operation.

A spark or flame can cause the battery to explode with enough force to kill or seriously hurt you.

Wear protective clothing and a face shield, or have a skilled mechanic do the battery maintenance.

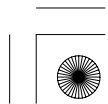
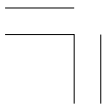



## Preparing for a Ride

---

A safe and enjoyable ride begins with good planning and preparation. Always ride with at least one other person in case you have trouble, and let someone know where you're going and when you expect to return.

Before riding in an unfamiliar area, find out in advance if you need special permits, get maps so you can study the terrain, and talk to other riders who know the area.

### What to Take to the Riding Area

Along with your ATV and riding gear, you should take along some tools and supplies in case you have a problem. For some of the difficulties you might encounter, see *Taking Care of the Unexpected*, which begins on page 181.



We recommend that you always take water, food, a first aid kit, and your owner's manual. Other items you should consider loading on your truck or trailer include:



- a tool kit
- tyre repair supplies and tools, and tyres
- extra parts, control levers, cables, and spark plugs
- wire, duct tape, and rope
- extra petrol

For safety, all refueling should be done at a gas station on the way to the riding area or at your base camp.





# Taking Care of the Unexpected

---

## General Guidelines

Keeping your ATV well-maintained is the best way to reduce the possibility of having a problem while riding. However, problems can arise even with well-maintained machines.

Remember to take along your owner's manual, the tool kit that came with your ATV, and any other items (such as tyre repair supplies and additional tools) that might help you solve a problem on your own.

If something goes wrong during a ride, the first thing to do is stop as soon as you safely can. Do not continue riding if you have a flat tyre, or you hear an unusual noise, or your ATV just doesn't feel right. If you continue riding, you could cause more damage and endanger your own safety.

After stopping, take time to assess the situation. Carefully inspect your ATV to identify the problem, then consider your options before you decide what to do.

If a problem is relatively minor and you have the tools, supplies, and skills to make a permanent repair, you may be able to fix it on the trail and continue riding. Or, you may be able to make a temporary repair that allows you to slowly ride back to your base where you can make a permanent repair or get help.

When a problem is more serious — or you don't have the tools, supplies, experience, or time to deal with it — you need to choose the safest way to get yourself and your ATV back to base. For example, if you are close enough, you (or you and another person) might be able to push it back.

## 182 Taking Care of the Unexpected





## If You Have a Flat Tyre

---

### Installation

1. Position the wheel.
2. Position the wheel nuts so that the tapered sides face the wheel rim (2).
3. Hand-tighten the wheel nuts on the wheel, then lower the ATV to the ground before tightening the nuts in a crisscross (rather than circular) pattern to the specified torque:  
64 N·m (6.5 kgf·m , 47 lbf·ft)

If a torque wrench was not used for installation, see your Honda dealer as soon as possible to verify proper assembly. Improper assembly may lead to loss of braking capability.

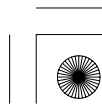



## If a Component Fails

---

The brake levers or pedal, control cables, and other components can be damaged as you ride in dense brush or over rocky terrain. Making a trailside repair depends on how serious the damage is and what tools and supplies you have with you.

- If any component of the brake system is damaged, you may be able to ride carefully back to your base using the other brake components for slowing or stopping.
- If you damage a throttle cable or other critical component, your ATV may be unsafe to ride. Carefully assess the damage and make any repairs that you can. But if there is any doubt, it's best to be conservative and safe.





# Table of Contents

The following presents the contents of each section of your owner’s manual.

<b>ATV SAFETY .....</b>	<b>1</b>
Important Safety Information .....	2
Safety Labels.....	5
<b>INSTRUMENTS &amp; CONTROLS.....</b>	<b>9</b>
Operation Component Locations .....	11
Indicators & Displays.....	14
Multi-function Display.....	18
Drive Mode Indicator.....	19
Gear Position Indicator.....	20
Oil Change Indicator .....	21
Odometer/Tripmeter.....	22
Hourmeter .....	24
Digital Clock .....	25
Fuel Gauge .....	26
Controls & Features .....	27
Ignition Switch.....	27
Shift Lever .....	28
Drive Mode Select Switch.....	29
2WD/4WD Select Switch .....	30
Start Button .....	31
Engine Stop Switch.....	31
Headlight Switch.....	32
Headlight Dimmer Switch.....	32
Horn Button.....	32
Recoil Starter.....	33
Throttle Lever .....	34





# Index

---

fuel,  
 fill cap ..... 112  
 gauge ..... 26  
 recommendation ..... 111  
 tank capacity ..... 112  
 fuses ..... 195

## G

gap, spark plug ..... 207  
 gear case oil ..... 122  
 gear shifting ..... 71

## H

headlight dimmer switch ..... 32  
 headlight switch ..... 32

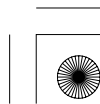
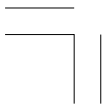

CLICK HERE TO **DOWNLOAD** THE COMPLETE MANUAL

- Thank you very much for reading the preview of the manual.
- You can download the complete manual from: [www.heydownloads.com](http://www.heydownloads.com) by clicking the link below



- Please note: If there is no response to CLICKING the link, please download this PDF first and then click on it.

CLICK HERE TO **DOWNLOAD** THE COMPLETE MANUAL