

724K 4WD Loader Operator's Manual

(PIN: 1DW724K_ _ _F658297—)



JOHN DEERE



OPERATOR'S MANUAL

724K 4WD Loader

(PIN: 1DW724K_ _ _F658297—)

OMT317764 ISSUE C3 (ENGLISH)

CALIFORNIA

Proposition 65 Warning

Diesel engine exhaust and some of its constituents are known to the State of California to cause cancer, birth defects, and other reproductive harm.

If this product contains a gasoline engine:

⚠ WARNING

The engine exhaust from this product contains chemicals known to the State of California to cause cancer, birth defects or other reproductive harm.

The State of California requires the above two warnings.

**Worldwide Construction
And Forestry Division**
PRINTED IN U.S.A.

CLICK HERE TO **DOWNLOAD** THE COMPLETE MANUAL

- Thank you very much for reading the preview of the manual.
- You can download the complete manual from: www.heydownloads.com by clicking the link below



- Please note: If there is no response to CLICKING the link, please download this PDF first and then click on it.

CLICK HERE TO **DOWNLOAD** THE COMPLETE MANUAL

CARB Non-road Emissions Control Warranty Statement—Compression Ignition

Emissions Control Warranty Statement 2019 through 2021

DXLOGOV1 —UN—28APR09



JOHN DEERE

CALIFORNIA EMISSIONS CONTROL WARRANTY STATEMENT YOUR WARRANTY RIGHTS AND OBLIGATIONS

To determine if the John Deere engine qualifies for the additional warranties set forth below, look for the "Emission Control Information" label located on the engine. If the engine is operated in the United States or Canada and the engine label states: "This engine complies with US EPA regulations for nonroad and stationary diesel engines", or "This engine complies with US EPA regulations for stationary emergency diesel engines", refer to the "U.S. and Canada Emission Control Warranty Statement." If the engine is operated in California, and the engine label states: "This engine complies with US EPA and CARB regulations for nonroad diesel engines" also refer to the "California Emissions Control Warranty Statement."

Warranties stated on this certificate refer only to emissions-related parts and components of your engine. The complete engine warranty, less emission-related parts and components, is provided separately. If you have any questions about your warranty rights and responsibilities, you should contact John Deere at 1-319-292-5400.

CALIFORNIA EMISSIONS CONTROL WARRANTY STATEMENT:

The California Air Resources Board (CARB) is pleased to explain the emission-control system warranty on 2019 through 2021 off-road diesel engines. In California, new off-road engines must be designed, built and equipped to meet the State's stringent anti-smog standards. John Deere must warrant the emission control system on your engine for the periods of time listed below provided there has been no abuse, neglect or improper maintenance of your engine.

Your emission control system may include parts such as the fuel injection system and the air induction system. Also included may be hoses, belts, connectors and other emission-related assemblies.

John Deere warrants to the ultimate purchaser and each subsequent purchaser that this off-road diesel engine was designed, built, and equipped so as to conform at the time of sale with all applicable regulations adopted by CARB and is free from defects in materials and workmanship which would cause the failure of a warranted part to be identical in all material respects to the part as described in John Deere's application for certification for a period of five years from the date the engine is delivered to an ultimate purchaser or 3,000 hours of operation, whichever occurs first for all engines rated at 19 kW and greater. In the absence of a device to measure hours of use, the engine shall be warranted for a period of five years.

EMISSIONS WARRANTY EXCLUSIONS:

John Deere may deny warranty claims for failures caused by the use of an add-on or modified part which has not been exempted by the CARB. A modified part is an aftermarket part intended to replace an original emission-related part which is not functionally identical in all respects and which in any way affects emissions. An add-on part is any aftermarket part which is not a modified part or a replacement part.

In no event will John Deere, any authorized engine distributor, dealer, or repair facility, or any company affiliated with John Deere be liable for incidental or consequential damage.

7. LIMITATION OF LIABILITY. EXCEPT AS SET FORTH IN THE LIMITED WARRANTY, UNDER NO CIRCUMSTANCES SHALL LICENSOR, ITS AFFILIATES OR ITS THIRD PARTY SUPPLIERS BE LIABLE TO YOU OR TO ANY THIRD PARTIES FOR DIRECT, INDIRECT, INCIDENTAL OR CONSEQUENTIAL DAMAGES OF ANY KIND, INCLUDING ANY LOSS OR DAMAGE CAUSED BY THE SOFTWARE; ANY PARTIAL OR TOTAL FAILURE OF THE SOFTWARE; PERFORMANCE, NONPERFORMANCE OR DELAYS IN CONNECTION WITH ANY INSTALLATION, MAINTENANCE, WARRANTY OR REPAIRS OF THE SOFTWARE, DAMAGES FOR CROP LOSS, DAMAGE TO LAND, LOST PROFITS, LOSS OF BUSINESS OR LOSS OF GOODWILL, LOSS OF USE OF EQUIPMENT OR SERVICES OR DAMAGES TO BUSINESS OR REPUTATION ARISING FROM THE PERFORMANCE OR NON-PERFORMANCE OF ANY ASPECT OF THIS AGREEMENT, WHETHER IN CONTRACT, TORT OR OTHERWISE, AND WHETHER OR NOT LICENSOR, ITS AFFILIATES OR ITS THIRD PARTY SUPPLIERS HAVE BEEN ADVISED OF THE POSSIBILITY OF SUCH DAMAGES. IN NO EVENT SHALL LICENSOR'S CUMULATIVE LIABILITY TO YOU OR TO ANY OTHER PARTY FOR ANY LOSSES OR DAMAGES RESULTING FROM ANY CLAIMS, LAWSUITS, DEMANDS, OR ACTIONS ARISING FROM OR RELATING TO USE OF THE SOFTWARE EXCEED YOUR TOTAL PAYMENT FOR THE MACHINE AND FOR THE LICENSE OF THE SOFTWARE.

8. Termination of License. Licensor may terminate the license granted under this Agreement upon written notice of termination provided to you if you violate any material term of this Agreement pertaining to your use of the Software or Licensor's rights, including, without limitation, the provisions of Sections 2 and 3 above.

9. Compliance with Law. You agree that you will use the Software in accordance with United States law and the laws of the country in which you are located, as applicable, including foreign trade control laws and regulations. The Software may be subject to export and other foreign trade controls restricting re-sales and/or transfers to other countries and parties. By accepting the terms of this Agreement, you acknowledge that you understand that the Software may be so controlled, including, but not limited to, by the Export Administration Regulations and/or the foreign trade control regulations of the Treasury Department of the United States. Any other provision of this Agreement to the contrary notwithstanding, you agree that the Software will not be resold, re-exported or otherwise transferred. The Software remains subject to applicable U.S. laws.

10. Indemnification. You agree to defend, indemnify and hold Licensor, its affiliates and third party supplier, and their, officers, directors, employees, agents and representatives (each an "Indemnified Party"), harmless

from and against all claims, demands proceedings, injuries, liabilities, losses, or costs and expenses (including reasonable legal fees) brought by any third party against any such persons arising from or in connection with your use of the Software, regardless of whether such losses are caused, wholly or partially, by any negligence, breach of contract or other fault of an Indemnified Party.

11. Costs of Litigation. If any claim or action is brought by either party to this License Agreement against the other party regarding the subject matter hereof, the prevailing party shall be entitled to recover, in addition to any other relief granted, reasonable attorney fees and expenses of litigation.

12. Severability and Waiver. Should any term of this Agreement be declared void or unenforceable by any court of competent jurisdiction, such declaration shall have no effect on the remaining terms hereof. The failure of either party to enforce any rights granted hereunder or to take action against the other party in the event of any breach hereunder shall not be deemed a waiver by that party as to subsequent enforcement of rights of subsequent actions in the event of future breaches.

13. Language Clause. If you are a resident of Canada at the time you accept this Agreement, then the parties hereby acknowledge that they have required this Agreement, and all other documents relating hereto, be drawn up in the English language only. Les parties reconnaissent avoir demandé que le présent contrat ainsi que toute autre entente ou avis requis ou permis à être conclu ou donné en vertu des stipulations du présent contrat, soient rédigés en langue anglaise seulement. If you are a resident of any country other than the United States, Canada, Great Britain, Australia or New Zealand then you agree as follows: there may be a translated version of this Agreement. If there is an inconsistency or contradiction between the translated version and the English version of this Agreement, the English version of this Agreement shall control.

14. Assignment by Licensor. Licensor may assign this Agreement without your prior consent to any company or entity affiliated with Licensor, or by an assignment associated with a corporate restructuring, merger or acquisition.

15. Governing Law and Forum. This Agreement will be governed by and construed in accordance with the substantive laws identified in the table in Section 18, below. The respective courts of the venue identified in the table in Section 18, below, for the location of the Machine shall have non-exclusive jurisdiction over all disputes relating to this Agreement. This Agreement will not be governed by the conflict of law rules of any jurisdiction or the United Nations Convention on Contracts for the International Sale of Goods, the application of which is expressly excluded.

16. Specific Exceptions.

	Page
Remove and Install Halogen Bulbs	4-1-12
Fluid Sampling Test Ports—If Equipped	4-1-13
Air Conditioning System Service	4-1-16
External Service Brake Inspection.....	4-1-17
Service Recommendations For	
Snap-To-Connect (STC®) Fittings	4-1-18
Welding on Machine	4-1-19
Welding Near Electronic Control Units	4-1-19
Keep Electronic Control Unit	
Connectors Clean	4-1-19
Replacing Bucket Teeth—TK Series	4-1-20
Keep ROPS Installed Properly	4-1-20
Hardware Torque Specifications.....	4-1-20
Metric Bolt and Screw Torque Values.....	4-1-21
Unified Inch Bolt and Screw Torque Values....	4-1-22
Bleeding Brakes	4-1-23

Miscellaneous—Operational Checkout

Operational Checkout.....	4-2-1
---------------------------	-------

Miscellaneous—Troubleshooting

Troubleshooting Procedure	4-3-1
Engine	4-3-2
Transmission	4-3-6
Differential and Axle	4-3-9
Service Brake	4-3-11
Driveline.....	4-3-11
Park Brake.....	4-3-12
Hydraulic System.....	4-3-13
Steering	4-3-15
Air Conditioning System	4-3-16
Heater System.....	4-3-18
Software Update.....	4-3-18

Miscellaneous—Storage

Prepare Machine for Storage	4-4-1
Monthly Storage Procedure.....	4-4-2
Preparing Engine for Long-Term Storage.....	4-4-3
Removing Engine From Long-Term Storage	4-4-4

Miscellaneous—Machine Numbers

Record Product Identification Number (PIN)	4-5-1
Record Engine Serial Number.....	4-5-1
Record Transmission Serial Number.....	4-5-1
Record Hydraulic Pump Serial Number.....	4-5-2
Record Front and Rear Axle Housing	
Serial Numbers	4-5-2
Keep Proof of Ownership	4-5-2
Keep Machines Secure	4-5-3

Miscellaneous—Specifications

Engine Specifications	4-6-1
Drain and Refill Capacities	4-6-1
Standard Z-Bar Specifications.....	4-6-2
High Lift Z-Bar Specifications	4-6-4
Travel Speeds	4-6-5
Eurasian Economic Union	4-6-6
Machine Design Life	4-6-6

Prevent Battery Explosions

Keep sparks, lighted matches, and open flame away from the top of battery. Battery gas can explode.

Never check battery charge by placing a metal object across the posts. Use a voltmeter or hydrometer.

Do not charge a frozen battery; it may explode. Warm battery to 16°C (60°F).

Keep battery electrolyte levels properly maintained.



Battery Explosions

TX,PREVENT,BATT -19-24FEB20-1/1

TS204—UN—15APR13

Clean Debris from Machine

Keep engine compartment, radiator, batteries, hydraulic lines, exhaust components, fuel tank, and operator's station clean and free of debris.

Clean any oil spills or fuel spills on machine surfaces.

Temperature in engine compartment could go up immediately after engine is stopped. **BE ON GUARD FOR FIRES DURING THIS PERIOD.**

Open access door(s) to cool the engine faster, and clean engine compartment.

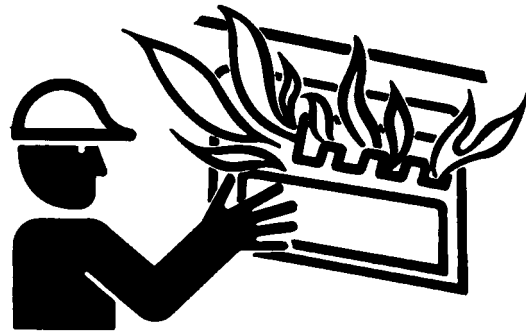

TX,DEBRIS -19-20JAN11-1/1

T6669AG—UN—15APR13

Handle Chemical Products Safely

Direct exposure to hazardous chemicals can cause serious injury. Potentially hazardous chemicals used with John Deere equipment include such items as lubricants, coolants, paints, and adhesives.

A Material Safety Data Sheet (MSDS) provides specific details on chemical products: physical and health hazards, safety procedures, and emergency response techniques.

Check the MSDS before you start any job using a hazardous chemical. That way you will know exactly what the risks are and how to do the job safely. Then follow procedures and recommended equipment.

(See your John Deere dealer for MSDS's on chemical products used with John Deere equipment.)



DX,MSDS,NA -19-03MAR93-1/1

TS1132—UN—15APR13

Safety—Maintenance Precautions

Park and Prepare for Service Safely

Warn others of service work. Always park and prepare your machine for service or repair properly.

- Park machine on a level surface and lower equipment to the ground.
- Engage park brake.
- Stop engine.
- Install frame locking bar.
- Attach a DO NOT OPERATE tag in an obvious place in the operator's station.
- Do not support machine with boom, bucket, or other hydraulically actuated equipment.
- Do not support machine with cinder blocks or wooden pieces that can crumble or crush.
- Do not support machine with a single jack or other devices that could slip out of place.

Securely support machine or attachment before working under it.

Install wheel chocks to ensure that machine cannot move backward or forward during service.

Understand service procedures before beginning repairs. Keep service area clean and dry. Use two people whenever the engine must be running for service work.

When performing above-ground maintenance, use appropriate support devices such as ladders, lifts, or platforms. If equipped, use the machine anchorage points and approved fall arrest harnesses and lanyards

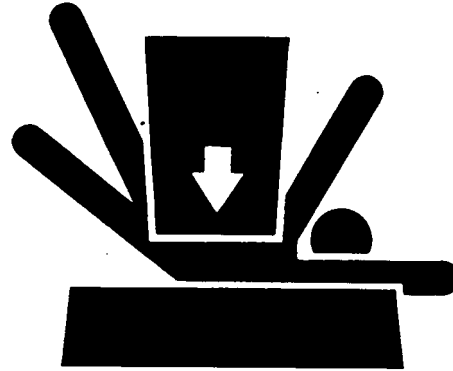

TX,PARK,4WD -19-26SEP22-1/1

T133332 —19—17APR13

TS229 —UN—23AUG88

Service Machines Safely

Tie long hair behind head. Do not wear a necktie, scarf, loose clothing, or necklace when working near machine tools or moving parts. If these items were to get caught, severe injury could result.

Remove rings and other jewelry to prevent electrical shorts and entanglement in moving parts.

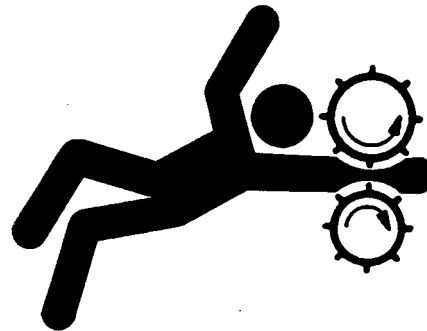

Service Machines Safely

TX,SERV,SAFE -19-08MAY20-1/1

TS228 —UN—23AUG88

9. **WARNING, Pressurized System**

Hot coolant can cause serious burns, injury, or death. Before opening the cooling system at the surge tank fill cap, stop the engine and wait until the cooling system components are cool. Loosen the cooling system pressure cap slowly in order to relieve the pressure.

This safety label is located on the surge tank cap.

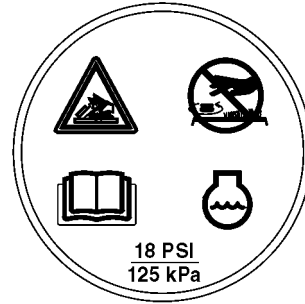

WARNING, Pressurized System

MB60223.0005017 -19-06SEP16-11/15

TX1149197 —UN—11DEC13

10. **WARNING, Avoid Injury From Release of High Pressure Oil**

AVOID INJURY FROM RELEASE OF HIGH PRESSURE OIL

Always discharge ride-control accumulator before disassembly of hydraulic lines.

See Operator's Manual for instructions.

This safety label is located on or near the ride control accumulator.



WARNING, Avoid Injury From Release of High Pressure Oil

MB60223.0005017 -19-06SEP16-12/15

TX1151287 —19—23JAN14

11. **WARNING, Avoid Injury From Escaping Fluid**

Avoid injury from escaping fluid. Contents of this accumulator are under pressure.

1. Refer to proper Machine Model Technical Manual for removal and installation procedure.
2. This accumulator is charged with DRY NITROGEN by the manufacturer and is NOT rechargeable.

This safety label is located on or near the brake accumulator.



WARNING, Avoid Injury From Escaping Fluid

Continued on next page

MB60223.0005017 -19-06SEP16-13/15

TX1141121 —19—25JUL13

- Press and release switch (LED is illuminated) to turn on marker lights.
- Press and release switch again (two LEDs are illuminated) to turn on drive lights and marker lights.
- Press and release switch again to turn off drive lights and marker lights (all LEDs are off).

NOTE: When marker or drive lights are turned on, the intensity of the backlighting on SSM will dim.

When a communication fault occurs between SSM and vehicle control unit (VCU) or a stuck button condition occurs, marker lights, drive lights, and backlighting turn on.

21—Lockup Torque Converter Switch: Press switch (LED is illuminated) to enable the lockup torque converter feature on machines equipped with the 5-speed transmission. Press switch again to disable feature (LED is off).

The lockup torque converter, when engaged, provides better fuel economy during material transport and more torque and speed when climbing steep inclines. The feature is physically controlled by the transmission control unit.

22—Rear Axle Disconnect Switch (if equipped): Feature not available on this model.

23—Rear Washer Switch: Press and hold switch to spray washer fluid on rear window and activate low speed rear wiper operation. Wiper blade swipes 5 times and turns off.

24—Rear Wiper Switch: This switch has four settings:

- Press and release switch (one LED is illuminated) for intermittent rear wiper operation.
- Press and release switch again (two LEDs are illuminated) for low-speed rear wiper operation.

- Press and release switch again (three LEDs are illuminated) for high-speed rear wiper operation.
- Press and release switch again to turn off rear wipers (all LEDs are off).

25—Cab Work Light Switch: This switch has three or four settings, depending on whether or not rear machine work light option is enabled.

If rear machine work light option is **not** enabled:

- Press and release switch (one LED is illuminated) to turn on front work lights and marker and taillight.
- Press and release switch again (two LEDs are illuminated) to turn on four front cab work lights, two rear cab work lights, and marker and taillight.
- Press and release switch again to turn off all lights (all LEDs are off).

If rear machine work light option is enabled:

- Press and release switch (one LED is illuminated) to turn on front work lights and marker and taillight.
- Press and release switch again (two LEDs are illuminated) to turn on four front cab work lights, two rear machine work lights, and marker and taillight.
- Press and release switch again (three LEDs are illuminated) to turn on four front cab work lights, two rear cab work lights, two rear machine work lights along with marker and taillight.
- Press and release switch again to turn off all lights (all LEDs are off).

NOTE: For courtesy light option to activate, engine must be running and marker lights turned on when light duration selection is made in the monitor. When the engine is turned off, the courtesy lighting shall activate and expire at the selected time. To set a duration time, see Display Unit—Main Menu—Settings—Courtesy Lights. (Section 2-3.)

JK05397.00050F5 -19-20SEP16-3/3

Counter Switch

The counter switch (1) is located on the right side of the operator's seat near the boom and bucket control levers. The switch consists of three individual buttons.

The SELECT COUNTER button allows the operator to select from up to five different counters which can correspond to five different aggregates. For more information, see Counter Switch Operation. (Section 2-2.)

The ADD BUCKET button and the ADD TRUCK button are used on machines equipped with the Embedded Payload Scale (EPS) system. For more information, see Embedded Payload Scale—If Equipped. (Section 2-2.)



Counter Switch

1— Counter Switch

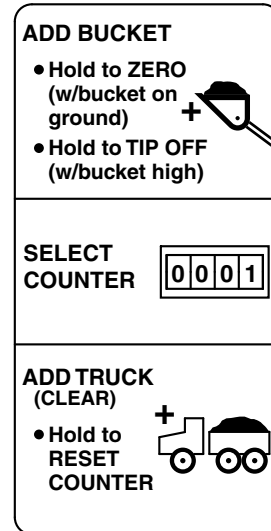

Counter Switch Label

OUT4001,000069F -19-15OCT11-1/1

TX1045645A—UN—15JUL08

TX1044805—19—10JUL08

Security System

The security system is designed to impede theft or unauthorized use of the machine. The system prevents the machine from starting until the operator correctly enters a valid security code when prompted during the startup sequence.

IMPORTANT: The default owner PIN set at factory is 1111. To maintain security, machine owner must change default PIN to another value. Owner must assign operator PINs as required and not provide owner PIN to anyone else.

The system provides for one master owner personal identification number (PIN) and up to ten operator PINs. Each PIN consists of up to eight numeric characters. Leading zeros are acceptable. For example, 001, 01, and 1 are each unique PINs.

The machine owner can perform any of the following security system functions:

- **Enable or disable security system.** See Display Unit—Main Menu—Security—Security. (Section 2-3.)
- **Change owner PIN.** See Display Unit—Main Menu—Security—Change Owner PIN. (Section 2-3.)
- **Manage and assign operator PINs.** See Display Unit—Main Menu—Security—Manage Operator PINs. (Section 2-3.)
- **Manage and assign transport PIN.** Transport PIN is for use by maintenance personnel and automatically expires after a preset time of 1—8 hours. See Display Unit—Main Menu—Security—Manage Transport PIN. (Section 2-3.)
- **Change operator logout delay time.** Logout delay time is a specified period of time after machine shutdown during which operator may restart machine without entering PIN. Time is either 0, 5, or 60 minutes. See Display Unit—Main Menu—Security—Delayed Operator Logout. (Section 2-3.)

SP66632,0004918 -19-22OCT13-1/1

Battery Disconnect Switch

Battery disconnect switch (1) is located on right side of machine, under right side cab platform.

Turn battery disconnect switch clockwise to turn ON machine electrical system.

Turn switch counterclockwise to turn OFF machine electrical system.

1— Battery Disconnect Switch

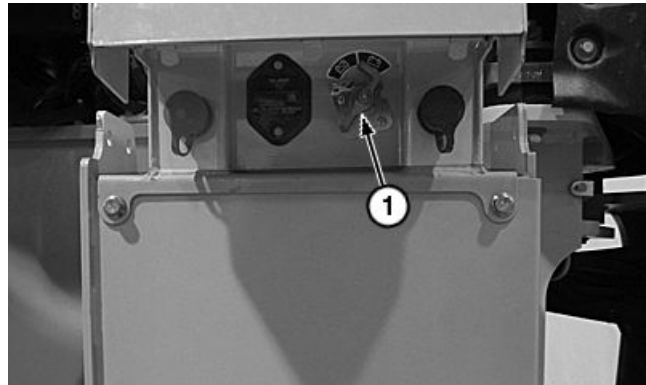

Battery Disconnect Switch

JK05397,0000513 -19-05SEP13-1/1

Automatic Idle and Automatic Shutdown

Automatic idle feature reduces the engine idle speed after the engine has operated at slow idle speed for a preset period of time. Slow idle speed is reduced from 900 rpm to 650 rpm.

Once the idle speed is lowered, the vehicle control unit (VCU) disables the clutch calibration mode, reversing fan function (if equipped), and hydraulics to ensure that the engine does not stall if the operator activates a hydraulic function at the reduced rpm.

Automatic idle can be enabled or disabled and set to activate after 1, 2, 3, 4, 5, 10, 15, 20, 25, or 30 minute increments from the service mode in the SETTINGS menu on the display unit. See your authorized dealer to activate automatic idle feature.

Automatic idle can be used as a stand-alone feature, but automatic shutdown can only be enabled when automatic idle feature is enabled.

Automatic shutdown feature turns off ignition power and shuts down the engine after the engine has been operating at a reduced automatic idle speed for a preset period of time.

Automatic shutdown can be enabled or disabled and set to activate after 1, 2, 3, 4, 5, 10, 15, 20, 25, or 30 minute increments from the service mode in the SETTINGS menu on the display unit. See your authorized dealer to activate automatic shutdown feature.

With automatic idle enabled, the VCU and the engine control unit (ECU) monitor various operating parameters. When all parameters meet prerequisites, the automatic

idle timer is started. If engine rpm changes during timer countdown, the timer is reset. When timer reaches zero, engine rpm is automatically reduced.

With automatic shutdown also enabled, the automatic shutdown timer is started when engine rpm is reduced by the automatic idle feature. When the timer reaches 30 seconds remaining, an audible alarm beeps once and a pop-up display shows a countdown timer indicating that the machine is about to power down. Momentarily increase the idle speed or activate a bucket function to deactivate automatic shutdown feature and return machine to slow idle speed.

The following prerequisites must be met for features to operate:

- Transmission is in neutral.
- Throttle is at idle.
- Vehicle speed is less than 0.5 km/h (0.31 mph).
- Engine coolant temperature is greater than a minimum value and less than a maximum value.
- Hydraulic oil temperature is less than a maximum value.
- Transmission oil temperature is less than a maximum value.
- Electrical system voltage is within specification.
- Clutch calibration is not active.
- Machine cannot be doing a regeneration or be in the service state.

If any of these parameters vary from preset values, or if CAN communication is lost with the ECU or transmission control unit (TCU), the machine will return to slow idle speed.

OUT4001,00005F5 -19-16JUL12-1/1

Selective Catalytic Reduction (SCR) System Overview

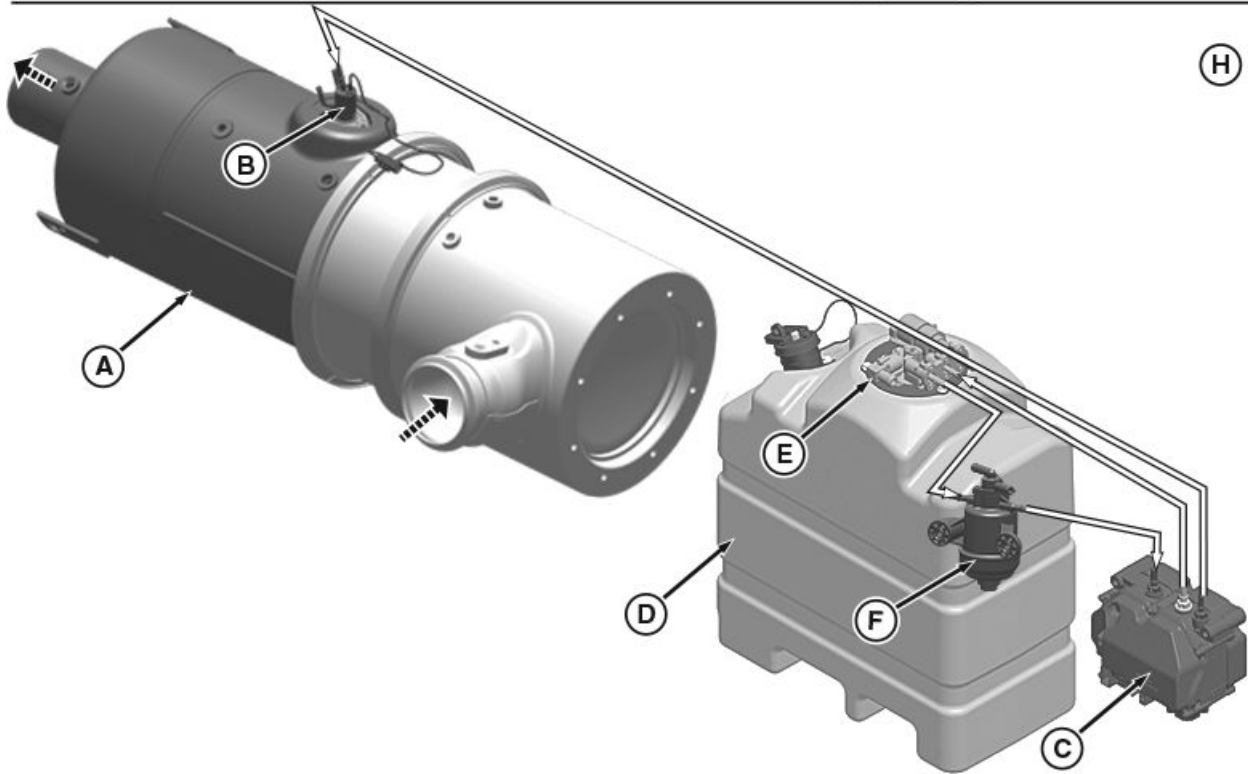
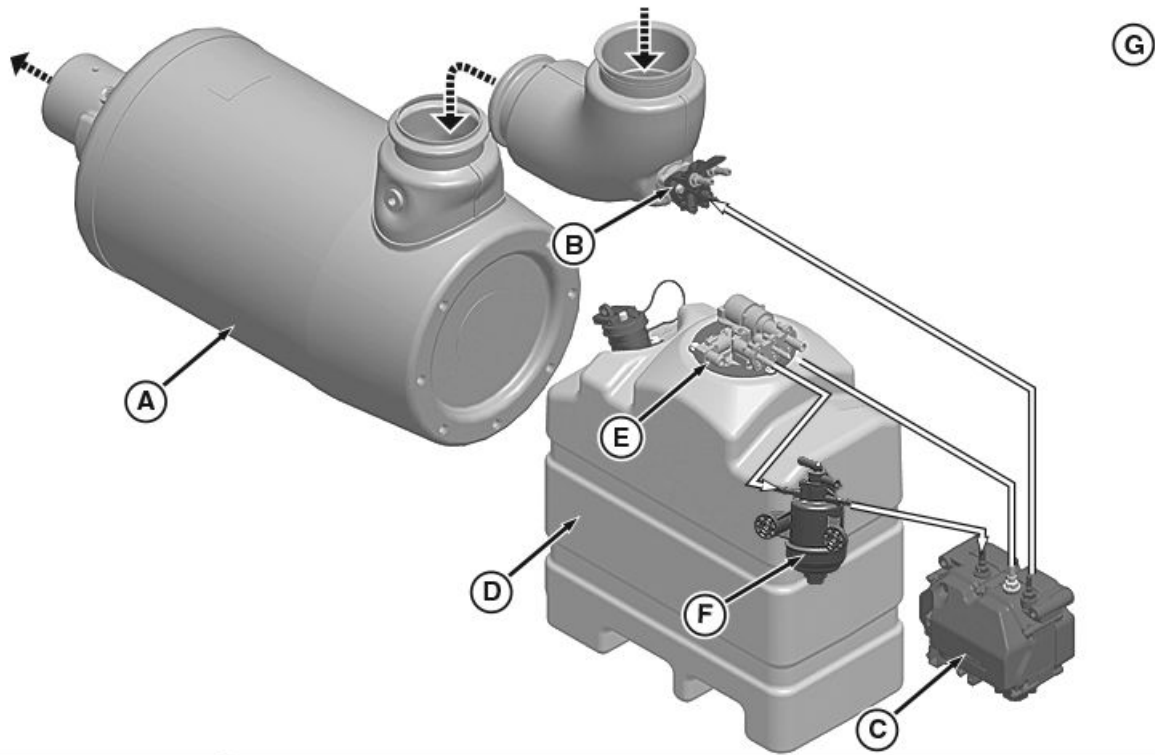

SCR System

A—SCR Catalyst
B—DEF Dosing Injector
C—DEF Dosing Unit

D—DEF Tank
E—DEF Tank Header Assembly
F—Inline DEF Filter (If Equipped)
G—Modular Canning Configuration
H—Inline Canning Configuration

RG22427A—UN—07JAN20

Continued on next page

DX,SCR,OVERVIEW -19-30MAR20-1/2

Clear Totals

To clear current truck total (short total), momentarily press ADD TRUCK button on counter switch.

To reset truck counter, press and hold ADD TRUCK button on counter switch for at least 1 second.

To clear long total, see Display Unit—Main Menu—Payload Scale—Long Total. (Section 2-3.)

Select CLEAR.

Obtain Accurate Weight Readings

The following factors can affect the accuracy of weight measurement:

- **Lifting Speed.** Weight lifted is calculated as a function of hydraulic boom lift pressure. Hydraulic pressure required to lift a load varies with the lifting speed. More accurate measurements are obtained when lifts are performed at a consistent and steady engine speed.
- **Trigger Point.** The trigger point is the boom position at which the weight measurement calculation occurs. On this machine, the trigger point is located at the point where the bottom of the bucket is approximately even with the top of the front work lights.
The load must be moving at a steady speed when it reaches the trigger point. The lift must start low enough that there are at least 2 seconds of lift before the trigger point.
- **Bounce.** Pneumatic tires can cause the machine to bounce when driven over rough ground. Bounce and steering will cause variations in hydraulic pressure and affect the accuracy of the weight measurement. The most accurate measurements are obtained while the machine is not moving.
- **Center of Gravity.** The center of gravity of the load affects hydraulic pressure in the lift cylinders and the accuracy of the weight measurement. Always roll the bucket fully back to the stops before lifting the load.
- **Zero Check.** When an empty bucket is raised past the trigger point, the weight measurement should be zero.

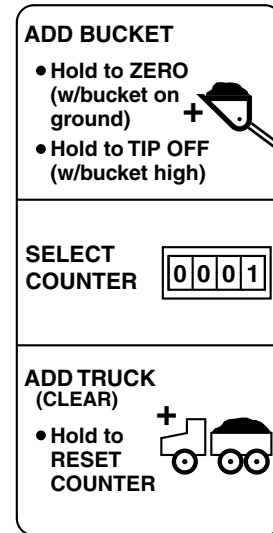

Counter Switch

When material builds up in the bucket, a corresponding zero error occurs. Perform zero check procedure as frequently as necessary.

Error Messages

Any of the following error messages may appear on the active weight display:

- Poor quality lift
- Lift speed too high
- Lift speed changed
- Bouncing load
- Bucket underloaded
- Bucket overloaded
- System not calibrated
- Zero check required
- Lifted weight too heavy to zero
- Lifted weight too light to zero

SP66632,0004911 -19-10DEC13-5/5

TX1044805—19—10JUL08

Stopping the Engine

Engine shutdown can be initiated by either the operator or the system.

The system can initiate shutdown only if the auto shutdown feature is enabled. To initiate auto shutdown, see Automatic Idle and Automatic Shutdown. (Section 2-2.)

The operator initiated shutdown is called the delayed shutdown.

Delayed Shutdown—To initiate a delayed shutdown:

1. Push and release engine STOP/ignition OFF switch on the sealed switch module.

NOTE: If no machine calibrations are active and the park brake is applied, the system will immediately enter delayed shutdown mode.

2. The system enters delayed shutdown mode as follows:
 - A pop-up will display confirming the delayed shutdown and will show a countdown timer.
 - When the countdown reaches zero, the engine stops and the ignition turns OFF.

The length of the delayed shutdown is calculated by the engine controller based on machine usage. The maximum countdown time is 10 minutes.

IMPORTANT: Prevent engine damage. Do not bypass delayed shutdown mode unless

absolutely necessary. Calculated countdown time allows turbocharger and engine components to cool down before shutdown.

3. To cancel or bypass delayed shutdown mode:
 - Hold the STOP button for 1 second or press it a second time to request an immediate shutdown.
 - Push the START button.
 - Shift the transmission into any gear.

Automatic Shutdown—Automatic shutdown feature turns off ignition power and shuts down the engine after the machine has been idle for a preset period of time.

Automatic shutdown can be disabled or set to activate after a predetermined time.

To enable/disable or adjust automatic shutdown time, see Automatic Idle and Automatic Shutdown. (Section 2-2.)

Conditions that must be met for auto shutdown to occur are:

- Transmission is in neutral or park
- Accelerator pedal is not pressed
- Vehicle speed is less than 0.5 km/h (0.31 mph)
- Engine coolant temperature is greater than a minimum value
- No calibrations are currently active

SP66632,000494B -19-08JUL15-1/1

Display Unit—Main Menu

The **MAIN MENU** displays seven submenus which can be selected to view diagnostic information or change various operating characteristics of the machine or the display unit.

NOTE: Translations shown on display may be abbreviated.

The MAIN MENU is accessed by pressing the SELECT button (3).

The submenus under MAIN MENU that appear on display (6) include:

1. **CODES**—allows service personnel or operator to view active or stored diagnostic trouble codes.
2. **SETTINGS**—allows the operator to change various operating characteristics of the machine.
3. **DIAGNOSTICS**—provides a limited set of tools, and is intended for use by service personnel and machine operators for diagnostic and troubleshooting functions.
4. **PAYLOAD SCALE**—if equipped, provides operator with information on weight of material being loaded and a means to change certain operating parameters and diagnose operation of the payload weighing system.
5. **SECURITY**—provides means for machine owner to assign personal identification numbers (PINs) to authorized operators to prevent theft or unauthorized use of the machine. When security system is on, operator must enter valid PIN when prompted or machine will not start.
6. **EXHAUST FILTER**—allows operator to enable or disable auto cleaning and start a parked cleaning, if needed.
7. **SOFTWARE DELIVERY**—allows operator the capability to accept, reject, or download Service ADVISOR™ Remote updates.

At MAIN MENU, press DOWN button (4) to move to desired submenu.

Service ADVISOR is a trademark of Deere & Company

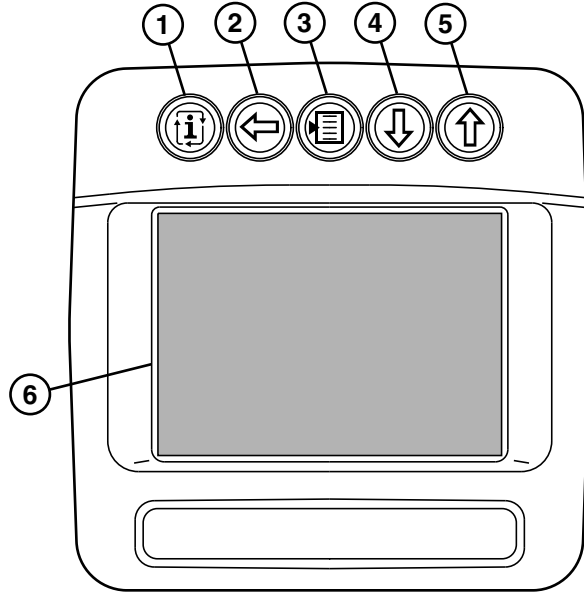

Display Unit

- | | |
|------------------|----------------|
| 1— INFO Button | 4— DOWN Button |
| 2— BACK Button | 5— UP Button |
| 3— SELECT Button | 6— Display |

Press SELECT button to activate chosen submenu.

Press BACK button (2) to return to previous menu.

Press INFO button (1) to return to runtime screen.

TX1051892 —UN—25NOV08

OUT4001,000058E -19-04NOV10-1/1

Display Unit—Main Menu—Diagnostics—Machine ID

The **MACHINE ID** menu provides the means to view the part number and serial number for control units, and the part number and version of software installed.

At DIAGNOSTICS menu, press UP button or DOWN button to highlight MACHINE ID.

Press SELECT button to display page 1 of the MACHINE ID menu.

MACHINE ID menu items on display include:

1. **SSM SEALED SWITCH MODULE**—Displays SSM part number, serial number, software part number, and software version.
2. **VCU VEHICLE CONTROLLER UNIT**—Displays VCU part number, serial number, software part number, and software version.
3. **ADU ADVANCED DISPLAY UNIT**—Displays ADU part number, serial number, software part number, and software version.
4. **TCU TRANSMISSION CONTROLLER**—Displays TCU software identification.
5. **JSV JOYSTICK STEERING VALVE**—Displays JSV part number, software part number, and software version. This display is available only on machines equipped with joystick steering option. For machines without joystick steering, a pop-up menu will appear stating that the option is not enabled or installed.
6. **RDR GROUND SPEED RADAR**—Displays RDR part number, serial number, software part number, and software version. This display is available only on

machines equipped with automatic differential lock option. For machines without automatic differential lock, a pop-up menu will appear stating that the option is not enabled or installed.

MORE...

MACHINE VIN—Displays vehicle identification number.

Press DOWN button to highlight MORE.

Press SELECT button to view page 2 of the MACHINE ID menu.

MACHINE ID menu items on page 2 display include:

1. **JDL JDLINK**—Displays JDL part number, serial number, software part number, and software version.
2. **TPM TIRE PRESSURE MONITOR**—Displays TPM model number, software part number, and software version.
3. **ECU ENGINE CONTROL UNIT**—Displays ECU part number and software part number.

MACHINE VIN—Displays vehicle identification number.

Press DOWN button to highlight the desired menu selection.

Press SELECT button to obtain information about the item selected.

Press BACK button to return to previous menu.

SP66632,000484C -19-03OCT13-1/1

Display Unit—Main Menu—Diagnostics—Battery Monitor

The **BATTERY MONITOR** menu displays the current voltage values of the left (inboard) and right (outboard) batteries.

At DIAGNOSTICS menu, press UP button or DOWN button to highlight BATTERY MONITOR.

Press SELECT button to view the current voltage values of the left and right batteries.

Press BACK button to return to previous menu.

NOTE: If 12 V center tap wire is not connected to the right battery, left battery displays system voltage and right battery displays 0.0.

OUT4001,000059D -19-21APR10-1/1

Display Unit—Main Menu—Payload Scale—Display Units

The **DISPLAY UNITS** menu allows the operator to select desired measurement unit for the values displayed. Selections include KG, POUNDS, TONS, and TONNES.

At **PAYLOAD SCALE** menu, press UP button or DOWN button to highlight **DISPLAY UNITS**.

Press **SELECT** button to view **DISPLAY UNITS** screen. Current measurement unit is on when a checkmark is displayed next to it.

To change, press UP button or DOWN button to highlight the desired measurement unit.

Press **SELECT** button to activate chosen measurement unit.

Press **BACK** button to return to previous menu.

OUT4001,00005AC -19-26APR10-1/1

Display Unit—Main Menu—Payload Scale—Auto Add

The **AUTO ADD** menu allows the operator to add the bucket load weight to the truck total weight automatically each time a load is lifted past the trigger point and control the amount of time the current load information is shown on the display unit.

At **PAYLOAD SCALE** menu, press UP button or DOWN button to highlight **AUTO ADD**.

Press **SELECT** button to display **AUTO ADD** menu.

AUTO ADD menu items on display include:

- **AUTO ADD**—Displays ON or OFF status of the auto add function. Press **SELECT** button to change to opposite setting.

- **AUTO ADD TIME**—Displays auto add time. The auto add time can be adjusted from 3—12 seconds but cannot be greater than the manual add time set at activation.

Press UP button or DOWN button to highlight **AUTO ADD TIME**.

Press **SELECT** button to view **AUTO ADD TIME** screen.

Press UP button to increase time or DOWN button to decrease time.

Press **BACK** button to return to previous menu.

OUT4001,00005AD -19-26APR10-1/1

Display Unit—Main Menu—Payload Scale—Diagnostics

The **DIAGNOSTICS** menu provides access to limited diagnostic information screens for use by the operator and various setup and diagnostic information screens for use by service personnel.

At **PAYLOAD SCALE** menu, press UP button or DOWN button to highlight **DIAGNOSTICS**.

Press **SELECT** button to display **DIAGNOSTICS** menu.

DIAGNOSTICS menu items on display include:

- **1- MACHINE READINGS**—Displays lift cylinder hydraulic lift pressure, hydraulic return pressure, boom height position, hydraulic oil temperature, and engine speed.

- **2- SPECIAL WEIGH**—Displays the last four values for weight lifted and the average weight, the last three speed values and the average speed, and it shows the last four values for boom lift, return and mixed.
- **3- DISPLAY CALIBRATION**—For use by service personnel. The values on the previous two screens can be analyzed to determine possible causes of inaccurate weight readings.

Press DOWN button to highlight the desired menu selection.

Press **SELECT** button to obtain information about the item selected.

Press **BACK** button to return to the previous menu.

OUT4001,00005AE -19-24MAY10-1/1

Display Unit—Main Menu—Payload Scale—Setup

The **SETUP** menu is for use by service personnel.

OUT4001,00005AF -19-26APR10-1/1

CLICK HERE TO **DOWNLOAD** THE COMPLETE MANUAL

- Thank you very much for reading the preview of the manual.
- You can download the complete manual from: www.heydownloads.com by clicking the link below



- Please note: If there is no response to CLICKING the link, please download this PDF first and then click on it.

CLICK HERE TO **DOWNLOAD** THE COMPLETE MANUAL

Display Unit—Main Menu—Software Delivery

The **SOFTWARE DELIVERY** menu is set by the dealer to enable Service ADVISOR™ Remote (SAR) software to be downloaded and installed on machine through the JDLink™ cellular connection. (For JDLink connection information, see Display Unit—Main Menu—Diagnostics—JDLink™ System Info in this section.) A series of screens will appear on the display monitor to walk the operator through the download and installation process. It will be necessary to interact with your John Deere dealer or technician for needed information.

The submenus under MAIN MENU that appear on display (6) include:

1. **CODES**
2. **SETTINGS**
3. **DIAGNOSTICS**
4. **PAYLOAD SCALE**
5. **SECURITY**
6. **EXHAUST FILTER**
7. **SOFTWARE DELIVERY**

Press DOWN button (4) at MAIN MENU to highlight SOFTWARE DELIVERY.

Press SELECT button (3) to display SOFTWARE DELIVERY menu.

NOTE: If software delivery has NOT been enabled by the dealer, a pop-up will appear on the monitor stating:

*SOFTWARE DELIVERY HAS NOT
BEEN ENABLED*

SEE DEALER TO ENABLE

SOFTWARE DELIVERY menu item on display is:

1. **SOFTWARE UPDATE**

*Service ADVISOR is a trademark of Deere & Company
JDLink is a trademark of Deere & Company*

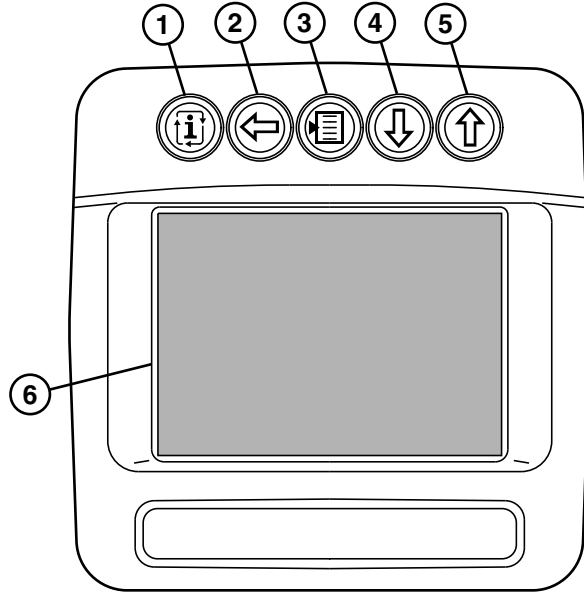

Display Unit

- | | |
|------------------|----------------|
| 1— INFO Button | 4— DOWN Button |
| 2— BACK Button | 5— UP Button |
| 3— SELECT Button | 6— Display |

Press SELECT button to activate menu item.

Press BACK button (2) to return to previous menu.

Press INFO button (1) to return to runtime screen at any time.

TX1051892 —UN—25NOV08

OUT4001,00006BE -19-03NOV10-1/1

Engine Oil and Filter Service Intervals — Interim Tier 4, Final Tier 4, Stage IIIB, Stage IV, and Stage V Engines

Failure to follow applicable oil standards and drain intervals can result in severe engine damage that might not be covered under warranty. Warranties, including the emissions warranty, are not conditioned on the use of John Deere oils, parts, or service.

Recommended oil and filter service intervals are based on a combination of oil pan capacity, type of engine oil and filter used, and sulfur content of the diesel fuel. Actual service intervals also depend on operation and maintenance practices.

Approved Oil Types:

- John Deere Plus-50™ II
- “Other Oils” include API CK-4, API CJ-4, ACEA E9, and ACEA E6

Use oil analysis to evaluate the condition of the oil and to aid in selection of the proper oil and filter service interval. Contact your John Deere dealer or other qualified service provider for more information on engine oil analysis.

Change the oil and oil filter at least once every 12 months even if the hours of operation are fewer than the otherwise recommended service interval.

Diesel fuel sulfur content affects engine oil and filter service intervals. Higher fuel sulfur levels reduce oil and filter service intervals.

Use of diesel fuel with sulfur content less than 15 mg/kg (15 ppm) is **REQUIRED**.

Plus-50 is a trademark of Deere & Company

Engine operation at high altitude decreases oil change intervals. See Diesel Engine Oil Service Interval for Operation at High Altitude for additional information.

NOTE: The 500 hour extended oil and filter change interval is only allowed if all of the following conditions are met:

- Use of diesel fuel with sulfur content less than 15 mg/kg (15 ppm)
- Use of John Deere Plus-50™ II oil
- Use of an approved John Deere oil filter

Engine Oil and Filter Service Intervals	
John Deere Plus-50™ II	500 hours
Other Oils	250 hours
Oil analysis may extend the service interval of “Other Oils” to a maximum not to exceed the interval of Plus-50™ II oils. Oil analysis means taking a series of oil samples at 50-hour increments beyond the normal service interval until either the data indicates the end of useful oil life or the maximum service interval of John Deere Plus-50 II oils is reached.	

IMPORTANT: To avoid engine damage:

- **Reduce oil and filter service intervals by 50% when using biodiesel blends greater than B20. Oil analysis may allow longer service intervals.**
- **Use only approved oil types.**

DX,ENOIL15,IT4,120toMAX -19-13JAN18-1/1

Diesel Engine Oil Service Interval for Operation at High Altitude

IMPORTANT: Diesel fuel sulfur content also affects engine oil and filter service intervals. See Engine Oil and Service Intervals in this section to determine the appropriate service interval prior to performing high altitude recommendations.

To avoid excessive oil degradation and potential engine damage, reduce oil and filter service intervals to 50% of the original recommended values when operating engines at altitudes above **1676 m (5500 ft)**.

Oil analysis may allow longer service intervals.

Use only approved oil types.

Example of Original Hours	Corresponding High Altitude Hours
125	60
150	75
175	85
200	100
250	125
275	135
300	150
350	175
375	185
400	200
500	250

TX,ENOIL,SERV,HIALT -19-24JUN20-1/1

Maintenance—Periodic Maintenance

Service Machine at Specified Intervals

IMPORTANT: Avoid machine damage. Perform scheduled maintenance on machine. See Service Intervals in this section and the following Maintenance sections for specific recommended intervals. This is also listed on the periodic maintenance chart located on machine.

Lubricate, clean, inspect machine, and make service checks and adjustments at intervals shown on the periodic maintenance chart (1) and in the following maintenance sections.

Periodic maintenance chart is located on front left side of loader frame.

Service items at multiples of the original requirement. For example, at 500 hours also service those items listed under 250 hours, 100 hours, 50 hours, and 10 hours or daily.

NeverGrease™ pin joints do not require lubrication. However, machines equipped with the NeverGrease™ pin joint option will have other maintenance points that still require lubrication.

1— Periodic Maintenance Chart



Periodic Maintenance Chart

TX1148102A—UN—21NOV13

NeverGrease is a trademark of Deere & Company

SP66632,000493E -19-21NOV13-1/1

Check Hour Meter Regularly

Check hour meter display (1) to determine when machine needs periodic maintenance.

Intervals on the periodic maintenance chart are for operation in normal conditions. If machine is operated in severe conditions, service it at SHORTER INTERVALS.

1— Hour Meter Display

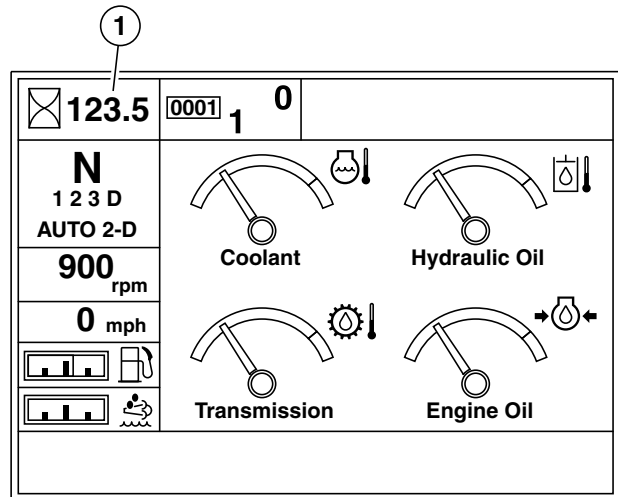

Hour Meter

TX1148136—UN—22NOV13

SP66632,0004940 -19-22NOV13-1/1

REQUIRED PARTS

Ensure machine performance and availability; use only genuine John Deere parts. Verify that part numbers are current and that any associated parts such as filter O-rings are also on hand.

Description	Initial Service —100 Hour ¹	Every 250 Hours	Every 500 Hours	Every 1000 Hours	Every 2000 Hours	Every 4000 Hours	Every 6000 Hours
Hydraulic Oil			1	1	1	1	1
Diesel Fuel			1	1	1	1	1
Engine Coolant			1	1	1	1	1

¹Perform initial service once after the first 100 hours of operation.

²Reduce service intervals to 1500 hours in severe applications, which run the torque converter at high loads for more than approximately 25% of the time.

³For recommended oil type and oil viscosities based on operating temperatures, see Maintenance—Machine. (Section 3-1.)

⁴Based on fluid analysis results, intervals may need to be adjusted for operating conditions. See an authorized John Deere dealer.

Plus-50 is a trademark of Deere & Company
 Hy-Gard is a trademark of Deere & Company
 Hydrau is a trademark of Deere & Company
 Cool-Gard is a trademark of Deere & Company

JK05397,00050D2 -19-06SEP17-2/2

Check Rear Camera and Radar Object Detection (ROD) System—If Equipped

IMPORTANT: Avoid machine damage. While performing operational checks given below, use mirrors or turn head to verify distances, in case system is not working properly.

NOTE: Inspect and check out rear camera and ROD system daily to verify proper operation. Inspect system more frequently due to operating or environmental conditions that could affect performance.

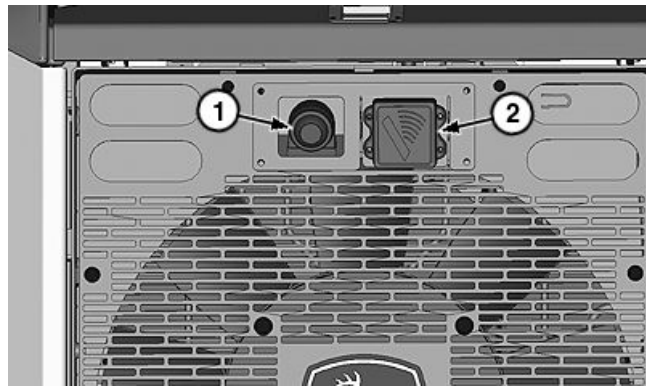

Rear Camera and ROD System

TX1148108A—UN—21NOV13

1. Inspect camera lens (1) and ROD system sensor face (2) for any accumulation of dirt, mud, snow, ice, or debris. Clean lens and sensor face as necessary.
2. Perform operational check of camera in each mode as follows:
 - a. Set camera to MANUAL mode. See Display Unit—Main Menu—Settings—Camera Mode. (Section 2-3.)
 - b. Press INFO button on display unit and verify that image from camera is displayed.
 - c. Select OBJECT mode.
 - d. Shift transmission in 1st gear reverse (1R) and back up to within 4.0 m (13.1 ft.) of a large object. Verify that image of object appears on display.
 - e. Move machine forward at least 5.0 m (16.4 ft.) away from object.
 - f. Select REVERSE mode.
 - g. Shift transmission into 1st gear reverse (1R). Verify that image from camera is displayed.
 - h. Select IN REVERSE WITH OBJECT mode.
 - i. Back up machine to within 4.0 m (13.1 ft.) of object. Verify that image of object is displayed.
3. Perform operational check of radar object detection (ROD) system as follows:
 - a. Turn ROD system to OFF mode using settings menu on display unit. See Display Unit—Main Menu—Settings. (Section 2-3.) Use the DOWN button to highlight MORE and press SELECT to display page 2 of Settings menu. Use the DOWN button to highlight OBJECT DETECT and press SELECT button to change detection mode.
 - b. Verify that green ROD system indicator with a slash through it is illuminated on display unit.
 - c. Turn ROD system to ON mode. Verify that display indicates that ROD system is ON and green indicator with no slash is illuminated on display unit.
 - d. Change display to the object detect diagnostics screen. See Display Unit—Main Menu—Diagnostics—Object Detect—If Equipped. (Section 2-3.)
 - e. Place transmission in 1st gear reverse (1R) and back up machine to within 4.0 m (13.1 ft.) of a large object.
 - f. Verify that alarm beeps and display indicates that object is detected.
 - g. Move machine closer to object. Verify that alarm beeps faster and display changes to indicate that object detected is now in closer detection zone.
4. If checkout of either camera or ROD system shows a performance problem, perform detailed checkout as follows, using an assistant:
 - a. Verify that camera lens and sensor face are clean.
 - b. Move machine to an area where rear of machine is clear of objects within 8.0 m (26.2 ft.).
 - c. Verify that ROD system is ON and camera is in OBJECT mode.
 - d. Move forward, neutral, or reverse (FNR) lever or FNR switch to N (neutral). Press park brake switch (LED on switch and indicator on display unit are illuminated).
 - e. Have assistant move to left rear corner of machine, in sight of rear view mirror. Have assistant walk toward centerline of machine in a path parallel to rear of machine. Note when image of assistant appears in display and alarm beeps.
 - f. Have assistant continue walking toward right side of machine. Note when alarm stops beeping and image of assistant is no longer displayed.

1— Camera Lens

2— Sensor Face

Continued on next page

SP66632,000493F -19-07JUL15-1/2

Maintenance—Initial Service—100 Hours

Replace Axle Oil Filters

1. The front axle oil filter (1) is located behind the front frame on left side of machine.
2. The rear axle oil filter (2) is located in the engine compartment on right side of machine.
3. Turn the axle oil filter counterclockwise to remove.
4. Apply light film of axle oil to gasket on new filters.
5. Install new axle oil filters. Turn filters clockwise by hand until gasket contacts mounting base.
6. Tighten filters an additional 1/2—3/4 turn.
7. Start engine and check for leaks around base of filters.

1— Front Axle Oil Filter

2— Rear Axle Oil Filter

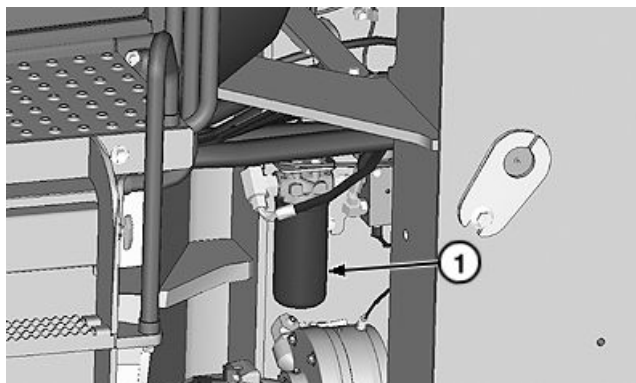

Front Axle Oil Filter

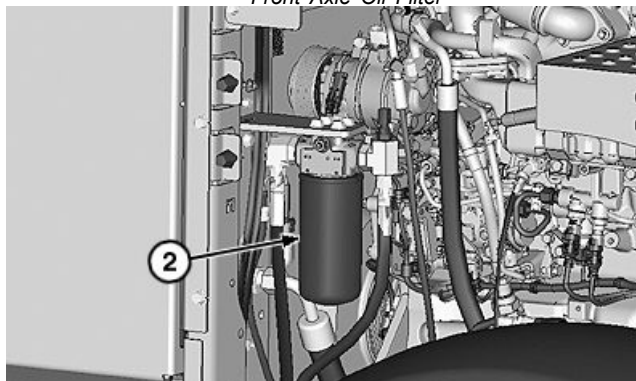

Rear Axle Oil Filter

TX1144946A—UN—03OCT13

TX1144947A—UN—03OCT13

SP66632,00048DE -19-12NOV13-1/1

Replace Final Fuel Filter

NOTE: Perform this service at 500 hour intervals when operating in normal conditions. When operating in dry, dusty conditions, replace fuel filter as necessary.

1. On left side of machine, open engine service door and side shield.
2. Clean area around final fuel filter (1).

NOTE: Some fuel will be present in final fuel filter housing.

3. Rotate final fuel filter counterclockwise and remove from mounting base. Dispose of used fuel filter properly.
4. Clean filter mounting base.

IMPORTANT: DO NOT prefill fuel filters. Debris in unfiltered fuel will damage fuel system components.

Only lube filter seal with diesel fuel before installing.

5. Install new final fuel filter onto mounting base. Rotate filter housing clockwise by hand. Tighten one turn after seal contacts mounting base.

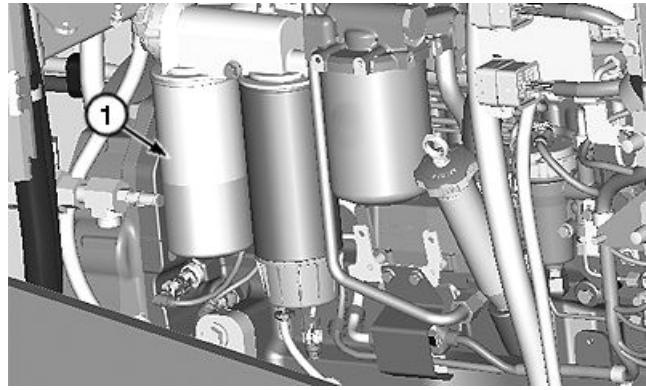

Final Fuel Filter

1—Final Fuel Filter

6. Close engine service door and side shield.
7. Prime fuel system and bleed air. See Bleed Fuel System. (Section 4-1.)

TX1084941A—UN—19NOV10

OUT4001,00006FC -19-30NOV10-1/1

Maintenance—Every 2000 Hours

Drain and Refill Transmission Oil and Replace Filter

NOTE: Shorten service intervals in severe applications which run the torque converter at high load more than approximately 25% of the time, such as basement digging or land clearing, or if using low viscosity oil.

The following chart shows the appropriate service interval in hours based on application and type of oil used.

Applica-tion	Oil Type and Service Interval (hours)	
	-John Deere Hy-Gard™ -Oils meeting JDM J20C	-John Deere Low Viscosity Hy-Gard™ -Oils meeting JDM J20D
Normal	2000	1500
Severe	1500	1000

1. Operate machine under load until transmission oil reaches normal operating temperature of 80° C (175° F).
2. Park machine on a level surface.
3. Lower bucket to ground.
4. Move forward, neutral, or reverse (FNR) lever or FNR switch to N (neutral).
5. Press park brake switch on sealed switch module (SSM) (LED on switch and indicator on display unit are illuminated).

CAUTION: Prevent possible injury from unexpected machine movement. Machine can unexpectedly roll or move under power, resulting in death or serious injury. Install frame locking bar and shut off engine before changing oil.

6. Install frame locking bar.
7. Shut off engine. Let machine sit for approximately 10 minutes.

NOTE: Drain plug is magnetic. If an excessive amount of metal particles appears on plug, see your John Deere dealer.

8. On left side, under the machine, remove tie band and route drain hose (1) through opening into a suitable container.
9. Open drain valve (2) and allow oil to drain into container. Dispose of waste oil properly.
10. Close drain valve. Fold up drain hose and retain with tie band.

Hy-Gard is a trademark of Deere & Company

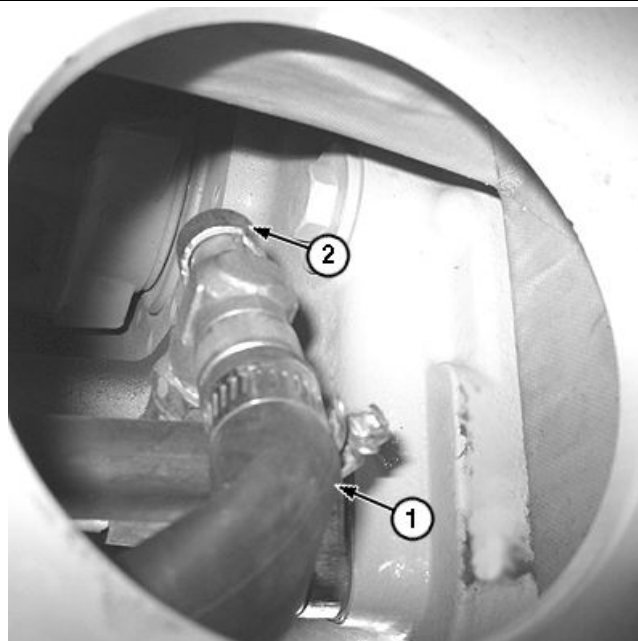

Transmission Drain Hose and Valve

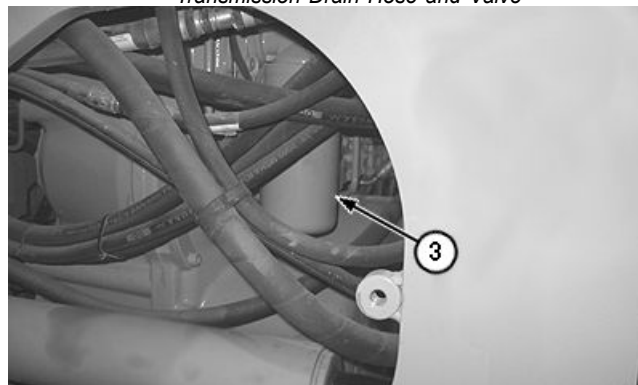

Transmission Oil Filter

1— Drain Hose
2— Drain Valve

3— Transmission Oil Filter

11. Remove transmission cover plate from right side of machine, under platform.
12. Turn transmission oil filter (3) counterclockwise to remove.
13. Clean mounting surface. Apply thin film of oil to gasket of new filter.
14. Install new filter. Turn filter clockwise by hand until gasket touches mounting surface.
15. Tighten 3/4 of a full turn more.

Continued on next page

JK05397.0000526 -19-10OCT13-1/2

TX1085115A—UN—24NOV10

TX1085116A—UN—24NOV10

Replace Hydraulic System Return Filter

1. Remove cap screws (1) and hydraulic reservoir service panel (2).

CAUTION: Hydraulic reservoir is pressurized. Remove fill cap slowly to relieve pressure.

2. Remove filter cover (3) from return filter (4).
3. Lift filter element (5) out of filter housing.
4. Install new filter element in housing.
5. Install filter cover. Tighten to specification.

Specification

Hydraulic Return Filter
 Cover—Torque.....75 N·m
 55 lb.-ft.

6. Install hydraulic reservoir service panel with cap screws.

- | | |
|--------------------------------------|-------------------|
| 1— Cap Screw (4 used) | 4— Filter Cover |
| 2— Hydraulic Reservoir Service Panel | 5— Filter Element |
| 3— Return Filter | |

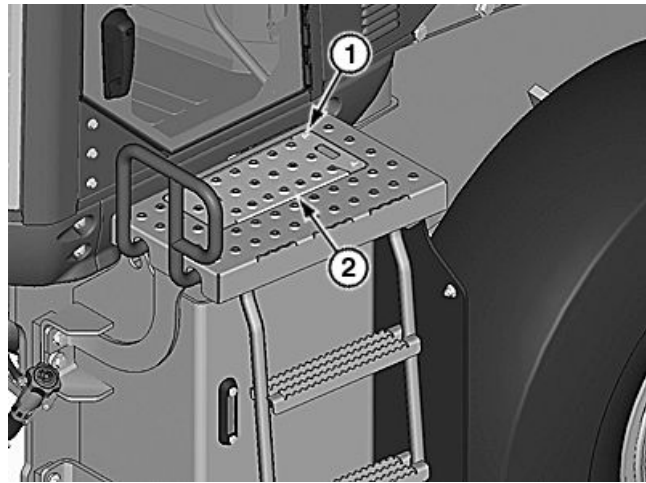

Hydraulic Reservoir Service Panel

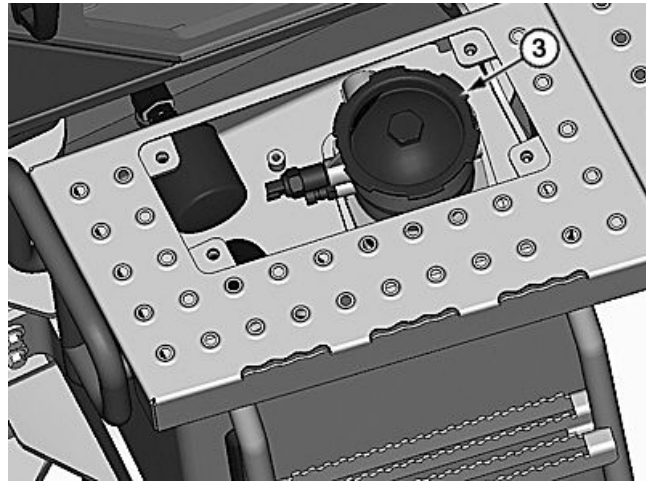

Hydraulic System Return Filter

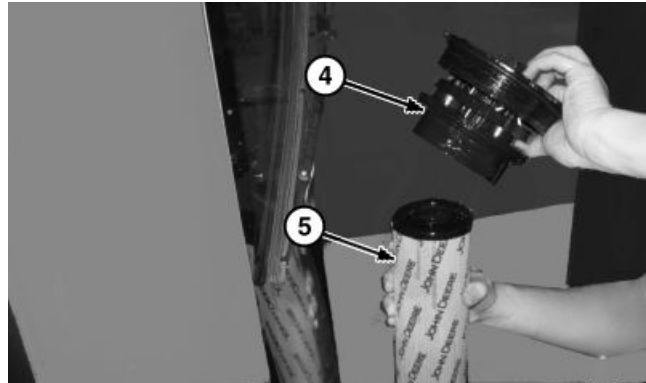

Filter Element and Cover

TX1145711A—UN—15OCT13

TX1145700A—UN—15OCT13

TX1029712A—UN—27SEP07

SP66632,00048A1 -19-21NOV13-1/1

Miscellaneous—Machine

Tire Removal With Tire Pressure Monitor (TPM) System—If Equipped

IMPORTANT: Avoid tire pressure sensor (1) damage. Follow instructions for tire removal when equipped with TPM system.

Follow these instructions when replacing tire (2) with TPM system installed or when replacing a bad tire pressure sensor:

1. Partially remove tire from rim allowing enough room to access the tire pressure sensor.

NOTE: Spring clamp (3) and sensor should be located near the valve stem (4).

2. Reach in and loosen hex screw on spring clamp (3).
3. Remove spring clamp and sensor assembly from rim.
4. Remove tire completely.

Installation of tire with TPM system installed:

1. Install tire partially.

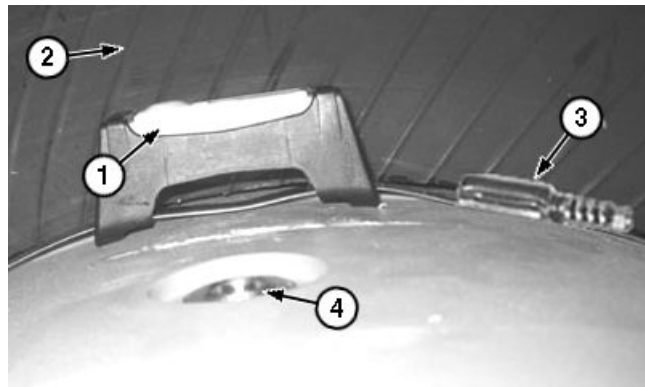

Tire Pressure Sensor

- | | |
|-------------------------|-----------------|
| 1— Tire Pressure Sensor | 3— Spring Clamp |
| 2— Tire | 4— Valve Stem |

2. Install spring clip and sensor assembly to rim.
3. Tighten hex screw on spring clamp.
4. Install tire completely.

OUT4001,00003F7 -19-19FEB15-1/1

TX106117A—UN—26JUN09

Check Air Inlet Cover

1. Loosen hose clamp (1).
2. Remove air inlet cover (2).
3. Check cover for dirt and debris and clean as required.
4. Install air inlet cover and tighten hose clamp.

- | | |
|---------------|--------------------|
| 1— Hose Clamp | 2— Air Inlet Cover |
|---------------|--------------------|

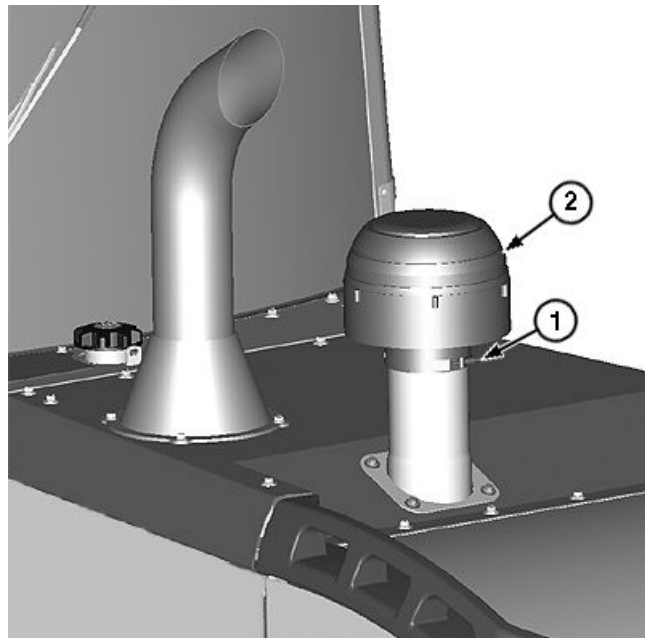

Air Inlet Cover

OUT4001,0000710 -19-29NOV10-1/1

TX1085159A—UN—29NOV10

- F01** — Voltage Converter Battery Power (25-Amp)
- F02** — Sealed Switch Module (SSM) Battery Power (5-Amp)
- F03** — Engine Control Unit (ECU) Battery Power (15-Amp)
- F04** — Voltage Converter Battery Power (15-Amp)
- F05** — Blower Motor (25-Amp)
- F06** — Engine Control Unit (ECU) Battery Power (15-Amp)
- F07** — Engine Control Unit (ECU) Battery Power (15-Amp)
- F08** — Electric Adjust/Heated Seat (20-Amp)
- F09** — Voltage Converter Ignition Power (10-Amp)
- F10** — Engine Control Unit (ECU) Ignition Power (5-Amp)
- F11** — RTD and Quick Shift Switches (7.5-Amp)
- F13** — Advanced Display Unit (ADU), Monitor Alarm, Turn Signal, and Counter Switch Ignition Power (5-Amp)
- F15** — Vehicle Control Unit (VCU) Ignition Power (15-Amp)
- F16** — Spare Ignition Power (15-Amp)
- F17** — Spare Battery Power (15-Amp)
- F18** — Transmission Control Unit (TCU) Battery Power (5-Amp)
- F19** — Dosing Pump—if equipped (15-Amp)
- F20** — Vehicle Control Unit (VCU) Battery Power (25-Amp)
- F21** — Vehicle Control Unit (VCU) Battery Power (15-Amp)
- F23** — Differential Lock, Steering Pressure, Park Brake Switch, and Ride Control Ignition Power (5-Amp)
- F28** — Transmission Control Unit (TCU) Ignition Power (5-Amp)
- F29** — Joystick Steering Ignition Power—if equipped (5-Amp)
- F30** — JDLink™ Battery Power (7.5-Amp)
- F31** — JDLink™ Ignition Power (5-Amp)
- F32** — Radar Object Detection (ROD) and Backup Alarm (5-Amp)
- F33** — Advanced Display Unit (ADU) Battery Power (5-Amp)
- F34** — EH Joystick Ignition Power—not used (5-Amp)
- F37** — Low-Pressure Fuel Pump Battery Power (15-Amp)
- F38** — Fuel Transfer Pump Ignition Power—if equipped (15-Amp)
- F40** — Transmission Output Speed Sensor Ignition Power (5-Amp)
- F41** — Ground Speed Radar (RDR) and Advanced Payload Scale (APS)—if equipped (10-Amp)
- F46** — 12 V Auxiliary Power (20-Amp)
- F49** — Service ADVISOR™ Engine and Dome Light Battery Power (5-Amp)
- F51** — 12 V Outlet Power (7.5-Amp)

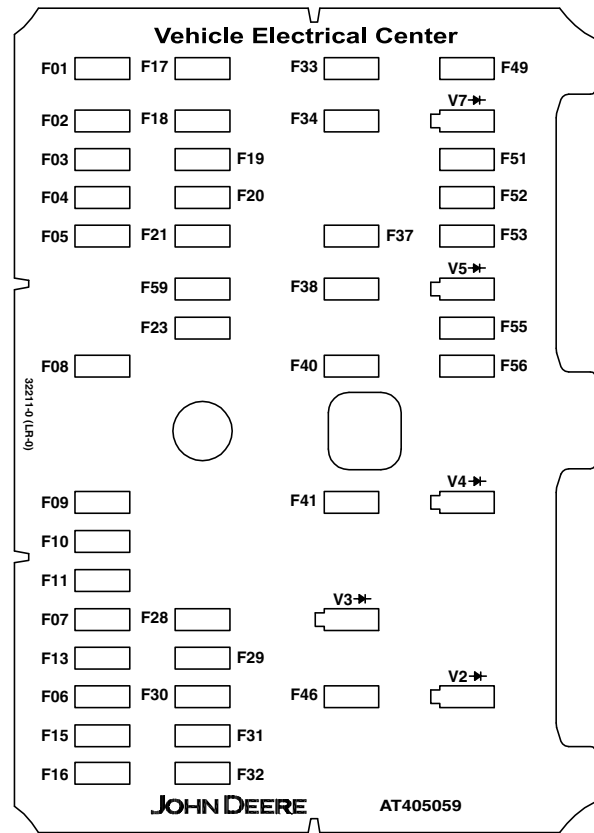

Fuse Block

- F52** — Rear Camera 12 V Power—if equipped (5-Amp)
- F53** — Alternator Excitation Ignition Power—if equipped (5-Amp)
- F55** — Front and Rear Wiper Motor Ignition Power (5-Amp)
- F56** — Tire Pressure Monitoring (TPM) System Ignition Power—if equipped (5-Amp)
- F59** — EH Joystick Battery Power—not used (5-Amp)
- V2** — Start Aid Solenoid Suppression Diode—if equipped (3-Amp)
- V3** — Ignition Relay Diode (3-Amp)
- V4** — Start Relay Diode (3-Amp)
- V5** — Alternator Excitation Diode—if equipped (3-Amp)
- V7** — Reverse Polarity Protection Diode (3-Amp)

Service ADVISOR is a trademark of Deere & Company

JK05397,000051C -19-29MAY14-2/2

TX1160057 —UN—29MAY14

Metric Bolt and Screw Torque Values

TS1742 —UN—31MAY18

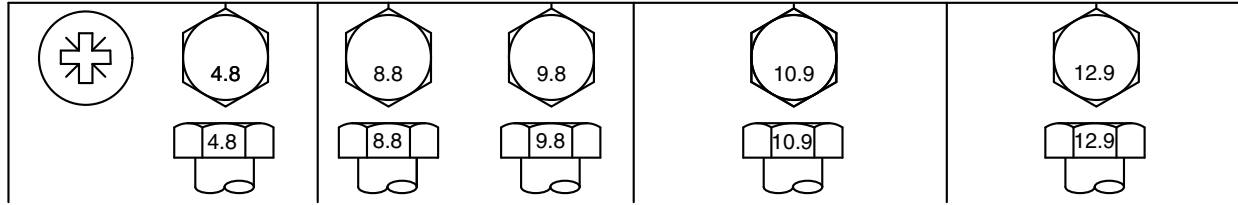

Bolt or Screw Size	Class 4.8				Class 8.8 or 9.8				Class 10.9				Class 12.9			
	Hex Head ^a		Flange Head ^b		Hex Head ^a		Flange Head ^b		Hex Head ^a		Flange Head ^b		Hex Head ^a		Flange Head ^b	
	N·m	lb-in	N·m	lb-in	N·m	lb-in	N·m	lb-in	N·m	lb-in	N·m	lb-in	N·m	lb-in	N·m	lb-in
M6	3.6	31.9	3.9	34.5	6.7	59.3	7.3	64.6	9.8	86.7	10.8	95.6	11.5	102	12.6	112
									N·m	lb-ft	N·m	lb-ft	N·m	lb-ft	N·m	lb-ft
M8	8.6	76.1	9.4	83.2	16.2	143	17.6	156	23.8	17.6	25.9	19.1	27.8	20.5	30.3	22.3
			N·m	lb-ft	N·m	lb-ft	N·m	lb-ft								
M10	16.9	150	18.4	13.6	31.9	23.5	34.7	25.6	46.8	34.5	51	37.6	55	40.6	60	44.3
	N·m	lb-ft														
M12	—	—	—	—	55	40.6	61	45	81	59.7	89	65.6	95	70.1	105	77.4
M14	—	—	—	—	87	64.2	96	70.8	128	94.4	141	104	150	111	165	122
M16	—	—	—	—	135	99.6	149	110	198	146	219	162	232	171	257	190
M18	—	—	—	—	193	142	214	158	275	203	304	224	322	245	356	263
M20	—	—	—	—	272	201	301	222	387	285	428	316	453	334	501	370
M22	—	—	—	—	365	263	405	299	520	384	576	425	608	448	674	497
M24	—	—	—	—	468	345	518	382	666	491	738	544	780	575	864	637
M27	—	—	—	—	683	504	758	559	973	718	1080	797	1139	840	1263	932
M30	—	—	—	—	932	687	1029	759	1327	979	1466	1081	1553	1145	1715	1265
M33	—	—	—	—	1258	928	1398	1031	1788	1319	1986	1465	2092	1543	2324	1714
M36	—	—	—	—	1617	1193	1789	1319	2303	1699	2548	1879	2695	1988	2982	2199

The nominal torque values listed are for general use only with the assumed wrenching accuracy of 20%, such as a manual torque wrench. DO NOT use these values if a different torque value or tightening procedure is given for a specific application. For lock nuts, for stainless steel fasteners, or for nuts on U-bolts, see the tightening instructions for the specific application.

Replace fasteners with the same or higher property class. If higher property class fasteners are used, tighten these to the strength of the original.

- Make sure that fastener threads are clean.
- Apply a thin coat of Hy-Gard™ or equivalent oil under the head and on the threads of the fastener, as shown in the following image.
- Be conservative with the amount of oil to reduce the potential for hydraulic lockup in blind holes due to excessive oil.
- Properly start thread engagement.

TS1741 —UN—22MAY18

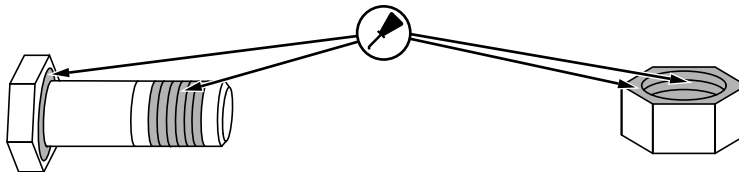

^aHex head column values are valid for ISO 4014 and ISO 4017 hex head, ISO 4162 hex socket head, and ISO 4032 hex nuts.

^bHex flange column values are valid for ASME B18.2.3.9M, ISO 4161, or EN 1665 hex flange products.

DX.TORQ2 -19-09MAY22-1/1

**Transmission
Gear Shift Switch
Checks—Steering
Column Mount Only**

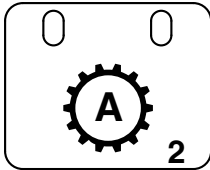

TX1028750 —UN—30AUG07

Automatic Transmission Switch

Push automatic transmission switch to OFF position (LEDs off).

Move steering column FNR/gear select switch to forward (F), neutral (N), and reverse (R) positions.

LOOK: Does steering column FNR/gear select switch move into forward, neutral, and reverse positions?

LOOK: Does steering column FNR/gear select switch stay in detented positions?

LISTEN: Does backup alarm activate when steering column FNR/gear select switch is in reverse position?

Rotate steering column FNR/gear select switch handle to select each gear: 1st, 2nd, 3rd, and D.

LOOK: Does gear number align with pointer in each detented position?

LOOK/FEEL: Does handle remain in detented positions?

LOOK: Does monitor display indicate neutral position (N) and correct gear (1, 2, 3, and D)?

YES: Go to next check.

NO: See your authorized John Deere dealer.

RG24095,000009E -19-12SEP16-13/47

**Transmission
Gear Shift Switch
Checks—Hydraulic
Control Lever Mount
Only**

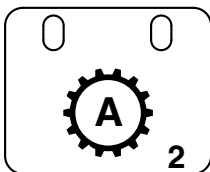

TX1028750 —UN—30AUG07

Automatic Transmission Switch

Push automatic transmission switch to OFF position (LEDs off).

Put gear shift switch in forward (F), neutral (N), and reverse (R) positions.

LOOK/FEEL: Does switch move into forward, neutral, and reverse positions?

LOOK: Does switch stay in detented positions?

LISTEN: Does backup alarm sound when in reverse?

Push upshift button and downshift button on hydraulic control lever.

LOOK: Does monitor display indicate neutral position (N) and correct gear (1, 2, 3, and D)?

YES: Go to next check.

NO: See your authorized John Deere dealer.

Continued on next page

RG24095,000009E -19-12SEP16-14/47

Transmission Shift Modulation Check

CAUTION: Prevent possible injury from machine movement. Perform this check in an open area away from other people and machinery.

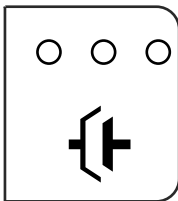

T194311 —UN—11SEP03

Clutch Cut-Off Enable Switch

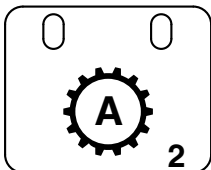

TX1028750 —UN—30AUG07

Automatic Transmission Switch

Push clutch cut-off enable switch to disable clutch cut-off (LEDs off).

Push automatic transmission switch to put transmission in manual mode (LEDs off).

CAUTION: To prevent personal injury fasten seat belt before performing this check. Machine will change directions abruptly!

Shift transmission to first forward.

Increase engine speed to fast idle and allow machine to reach full travel speed in first gear.

Shift from forward to reverse, then reverse to forward several times while allowing machine to reach full speed in forward and reverse before changing directions.

Repeat check in second gear.

LOOK: Does machine slow down and change direction smoothly?

Drive machine in second gear with engine speed at fast idle.

Apply service brakes to slow engine down to 1800 rpm, then while still holding service brakes, shift to first gear.

FEEL: Does transmission shift smooth without jerking?

YES: Go to next check.

NO: See your authorized John Deere dealer.

Continued on next page

RG24095.000009E -19-12SEP16-28/47

Cycle Time Check

CAUTION: Prevent possible injury from unexpected machine movement. Clear all persons from the area before operating machine.

NOTE: All systems must be warmed up to operating range to get accurate test results.

Use advanced display unit (ADU) or Service ADVISOR™ application to observe engine rpm and hydraulic oil temperature.

Specification

Hydraulic Oil—Temperature..... 60—71°C
 140—160°F
 Engine—Speed..... Fast Idle

Perform each function three times and take an average of the times for a cycle time.

Record cycle time for each function.

Standard Lift Z-Bar—Specification

Boom Raise—Cycle Time.....6.4 seconds
 Boom Lower (float)—Cycle Time.....3.0 seconds
 Boom Lower (power down)—Cycle
 Time.....3.3 seconds
 Bucket Dump (boom at full
 height)—Cycle Time.....1.4 seconds
 Steering Wheel (stop to stop)—Turns.....3.5
 Orbital Steering (stop to stop)—Cycle
 Time.....2.4 sec.
 Joystick Steering (stop to stop)—Cycle
 Time.....2.7 sec.

High Lift Z-Bar—Specification

Boom Raise—Cycle Time.....6.4 seconds
 Boom Lower (float)—Cycle Time.....3.0 seconds
 Boom Lower (power down)—Cycle
 Time.....3.3 seconds
 Bucket Dump (boom at full
 height)—Cycle Time.....1.6 seconds
 Steering Wheel (stop to stop)—Turns.....3.5
 Orbital Steering (stop to stop)—Cycle
 Time.....2.4 sec.
 Joystick Steering (stop to stop)—Cycle
 Time.....2.7 sec.

LOOK: Are cycle times at specification?

YES: Go to next check.

NO: See your authorized John Deere dealer.

Continued on next page

RG24095.000009E -19-12SEP16-44/47

Symptom	Problem	Solution
Transmission Shifts Too Slow	Electronic control system problem or basic transmission problem	See your authorized dealer.
	Low transmission oil level (aeration of oil)	Check transmission oil level. See Check Transmission Oil Level. (Section 3-4.)
Transmission Hydraulic System Overheats	Restricted transmission pump suction screen	Remove and clean suction screen.
	Electronic control system problem or basic transmission problem	See your authorized dealer.
	High transmission oil level	Check transmission oil level. See Check Transmission Oil Level. (Section 3-4.)
	Low transmission oil level	Check transmission oil level. See Check Transmission Oil Level. (Section 3-4.)
	Wrong transmission oil grade	Use correct grade of transmission oil. See Transmission, Park Brake, and Axle Oil. (Section 3-1.)
	Park brake dragging	Check for heat in park brake area.
	Pinched, restricted or leaking lube lines	Check cooler lines.
	Malfunction in temperature gauge or sender	Install temperature sensor to verify temperature. See your authorized dealer.
Excessive Transmission Noise (under load or no load)	Restricted air flow through oil cooler or radiator	Check oil cooler and radiator for debris. Clean if needed.
	Internal transmission problem	See your authorized dealer.
	Worn parts or damaged transmission	Inspect suction screen for metal particles. If metal particles are present, see your authorized dealer.
	Damaged output damper	Inspect output damper. If output damper is damaged, see your authorized dealer.
	Driveline or park brake	Inspect driveline and park brake. If any part of the driveline or park brake is damaged, see your authorized dealer.

Continued on next page

JK05397,000003E -19-13NOV13-2/3

Symptom	Problem	Solution
	Heater or evaporator core fins restricted	Clean heater or evaporator core fins.
	Pressurizer blower motor malfunction or operating too slowly	Check motor speed. See an authorized dealer.
	Compressor clutch slipping or malfunction	Inspect and/or replace compressor clutch. See an authorized dealer.
	Warm outside air leaking into cab	Inspect, repair or replace door and window seals.
	Heater valve remaining open	Inspect and repair, adjust or replace heater valve or cable. See an authorized dealer.
	System refrigerant (R134A) charge low	Inspect system for leaks.
	Evaporator fins frosting or freezing	Freeze control switch capillary tube not positioned correctly in evaporator core. See an authorized dealer.
Air Conditioner Runs Constantly, Too Cold	Freeze control switch capillary tube not positioned in evaporator correctly	Reposition capillary tube in evaporator core.
Interior Windows Continue to Fog	Fresh air filter restricted	Clean or replace fresh air filter. See Check and Clean or Replace Cab Fresh Air Filter. (Section 3-3.)
	Air conditioning system off	Press and release air conditioner switch to turn ON air conditioner and place temperature control knob at midrange. See Air Conditioner and Heater Operation. (Section 2-1.)

OUT4001,00005C3 -19-01NOV16-2/2

Standard Z-Bar Specifications

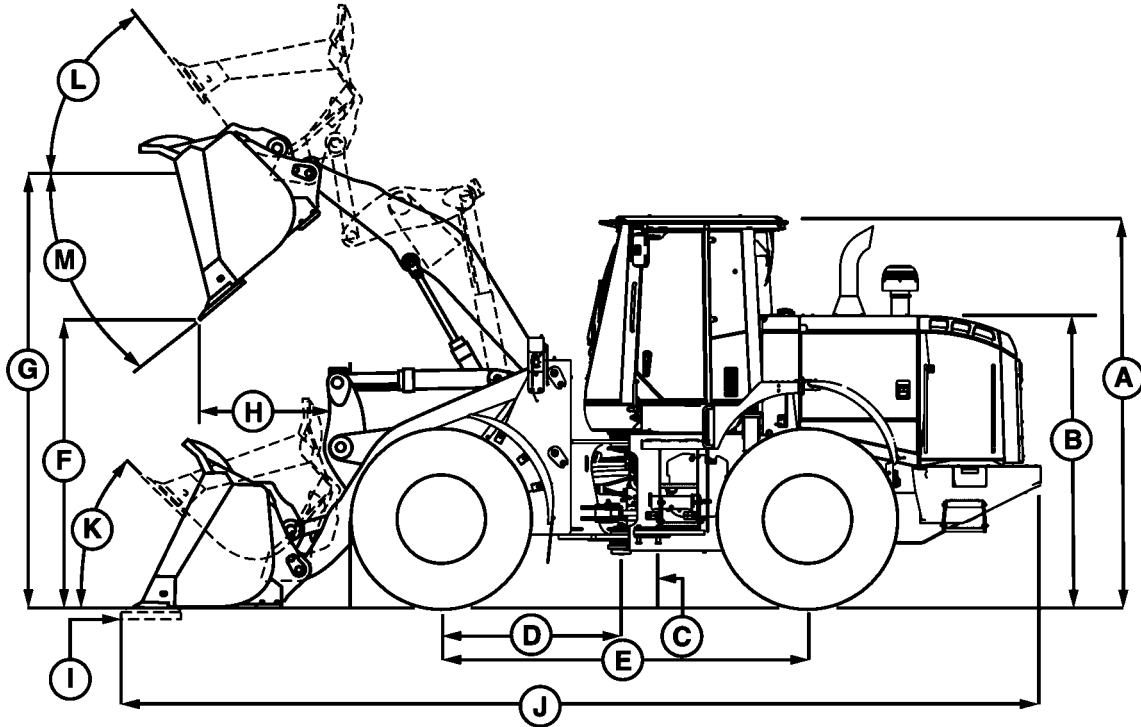

TX1144640

Standard Z-Bar Linkage

- | | | | |
|-----------------------------------|-------------------------|------------------------------------|------------------------------|
| A—Overall Machine Height | E—Wheelbase Length | J—Overall Machine Length | M—Bucket Dump at Full Height |
| B—Hood Height | F—Dump Clearance Height | K—Maximum Rollback at Ground Level | |
| C—Machine to Ground Clearance | G—Bucket Hinge Height | L—Maximum Rollback at Full Height | |
| D—Centerline to Front Axle Length | H—Dump Reach | | |
| I—Maximum Digging Depth | | | |

NOTE: Specifications and design subject to change without notice. Wherever applicable, specifications are in accordance with ISO standards. Loader operating information is based on machine with identified linkage and standard equipment, ROPS cab, rear cast bumper/counterweight, transmission

side-frame guards, bottom guards, standard tires, full fuel tank, 4.75 cu. yd. (3.6 m³) general purpose bucket with bolt-on edge, and 175-lb. (79 kg) operator. This information is affected by changes in tires, ballast, and different attachments.

Item	Measurement	Specification
A—Overall Machine	Height	3.43 m 11 ft. 3 in.
B—Hood	Height	2.53 m 8 ft. 4 in.
C—Machine to Ground	Clearance	461 mm 1 ft. 6 in.
D—Centerline to Front Axle	Length	1.60 m 5 ft. 3 in.
E—Wheelbase	Length	3.26 m 10 ft. 8 in.
F—Dump Clearance	Height	2.84 m 9 ft. 4 in.
G—Bucket Hinge	Height	4.12 m 13 ft. 6 in.

Continued on next page

JK05397.0000029 -19-05NOV13-1/2

TX1144640—UN—26SEP13

CLICK HERE TO **DOWNLOAD** THE COMPLETE MANUAL

- Thank you very much for reading the preview of the manual.
- You can download the complete manual from: www.heydownloads.com by clicking the link below



- Please note: If there is no response to CLICKING the link, please download this PDF first and then click on it.

CLICK HERE TO **DOWNLOAD** THE COMPLETE MANUAL