

CONTENTS

Foreword	0-1	7. Efficient working method	4-16	
Before servicing this machine	0-2	8. Operation in the special work sites	4-20	
EC regulation approved	0-3	9. Normal operation of excavator	4-22	
Table to enter S/No and distribution	0-4	10. Attachment lowering	4-23	
Safety labels	0-5	11. Storage	4-24	
Machine data plate	0-18	12. RCV lever operating pattern	4-26	
Guide (direction, S/No, symbol)	0-19	13. Switching hydraulic attachment circuit	4-28	
SAFETY HINTS		14. Regeneration system	4-29	
1. Before operating the machine	1-1	TRANSPORTATION		
2. During operating the machine	1-16	1. Preparation for transportation	5-1	
3. During maintenance	1-23	2. Dimension and weight	5-2	
4. Parking	1-26	3. Loading the machine	5-5	
SPECIFICATIONS		4. Fixing the machine	5-7	
1. Major components	2-1	5. Loading and unloading by crane	5-8	
2. Specifications	2-2	MAINTENANCE		
3. Working range	2-5	1. Instruction	6-1	
4. Weight	2-7	2. Tightening torque	6-6	
5. Lifting capacities	2-9	3. Fuel, coolant and lubricants	6-9	
6. Bucket selection guide	2-12	4. Maintenance check list	6-11	
7. Undercarriage	2-14	5. Maintenance chart	6-16	
8. Specification for major components	2-16	6. Service instruction	6-18	
9. Recommended oils	2-19	7. Electrical system	6-42	
CONTROL DEVICES		8. Air conditioner and heater	6-45	
1. Cab devices	3-1	TROUBLESHOOTING GUIDE		
2. Cluster	3-2	1. Engine	7-1	
3. Switches	3-27	2. Electrical system	7-2	
4. Levers and pedals	3-32	3. Others	7-3	
5. Air conditioner and heater	3-34	HYDRAULIC BREAKER AND QUICK CLAMP		
6. Others	3-38	1. Selecting hydraulic breaker	8-1	
OPERATION		2. Circuit configuration	8-2	
1. Suggestion for new machine	4-1	3. Maintenance	8-3	
2. Check before starting the engine	4-2	4. Precaution while operating the breaker	8-4	
3. Starting and stop the engine	4-3	5. Quick clamp	8-6	
4. Mode selection system	4-7	INDEX		9-1
5. Operation of the working device	4-12			
6. Traveling of the machine	4-13			

CLICK HERE TO **DOWNLOAD** THE COMPLETE MANUAL

- Thank you very much for reading the preview of the manual.
- You can download the complete manual from: www.heydownloads.com by clicking the link below



- Please note: If there is no response to CLICKING the link, please download this PDF first and then click on it.

CLICK HERE TO **DOWNLOAD** THE COMPLETE MANUAL

11) SIDE KEEP CLEAR (item 13)

This warning label is positioned on the side of LH rear side cover.

- ⚠ To prevent serious personal injury or death keep clear of machine swing radius.
- ⚠ Do not deface or remove this label from the machine.

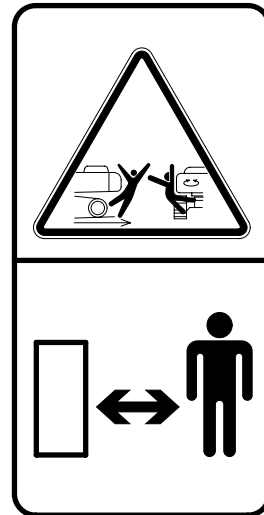

21070FW13

12) STAY FIX

- ⚠ Be sure to support the stay when the door needs to be opened.
- ⚠ Be careful that the opened door may be closed by the external or natural force like strong wind.

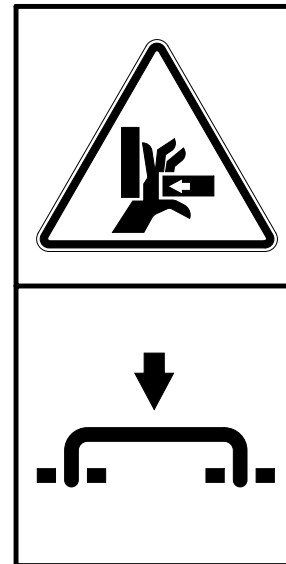

21070FW14

13) SHEARING-ENGINE HOOD (item 15)

This warning label is positioned on the engine hood.

- ⚠ Don't open the engine hood during the engine's running.
- ⚠ Don't touch exhaust pipe or it may cause severe burn.

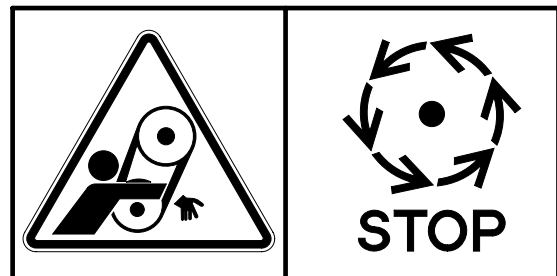

21070FW15

GUIDE

1. DIRECTION

The direction of this manual indicate forward, backward, right and left on the standard of operator when the travel motor is in the rear and machine is on the traveling direction.

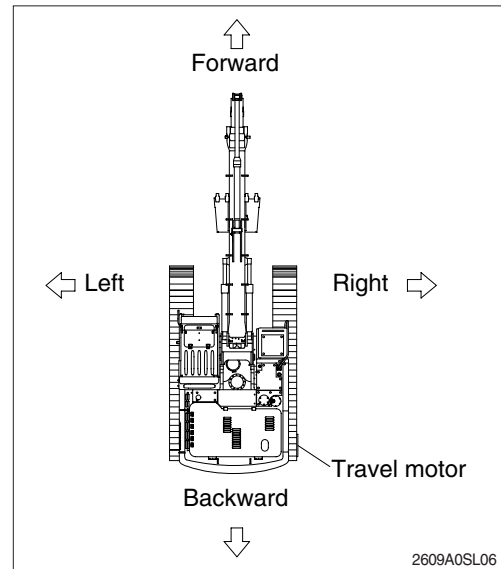

2. SERIAL NUMBER

Inform following when you order parts or the machine is out of order.

1) MACHINE SERIAL NUMBER

The numbers are located below the right window of the operator's cab.

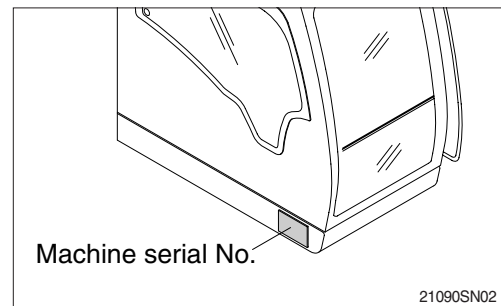

2) ENGINE SERIAL NUMBER

The numbers are located on the engine name plate.

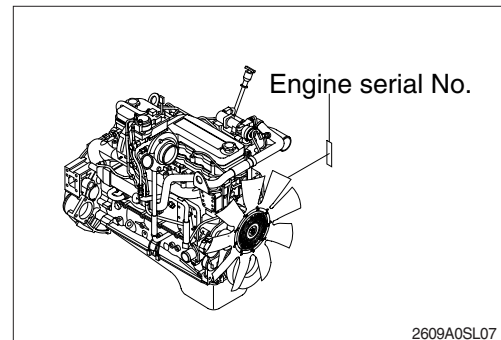

3. INTENDED USE

This machine is designed to be used mainly for the following work.

- Digging work
- Loading work
- Smoothing work
- Ditching work

※ Please refer to the section 4 (efficient working method) further details.

4. SYMBOLS

▲ Important safety hint.

△ It indicates matters which can cause the great loss on the machine or the surroundings.

It indicates the useful information for operator.

Lines, Tubes, and Hoses

Do not bend high-pressure lines. Do not strike high-pressure lines. Do not install any lines that are bent or damaged. Use the appropriate backup wrenches in order to tighten all connections to the recommended torque.

Check lines, tubes, and hoses carefully. Wear Personal Protection Equipment (PPE) in order to check for leaks. Always use a board or cardboard when you check for a leak. Leaking fluid that is under pressure can penetrate body tissue. Fluid penetration can cause serious injury and possible death. A pin hole leak can cause severe injury. If fluid is injected into your skin, you must get treatment immediately. Seek treatment from a doctor that is familiar with this type of injury.

Replace the affected parts if any of the following conditions are present :

- End fittings are damaged or leaking.
- Outer coverings are chafed or cut.
- Wires are exposed.
- Outer coverings are swelling or ballooning.
- Flexible parts of the hoses are kinked.
- Outer covers have exposed embedded armoring.
- End fittings are displaced.

Make sure that all clamps, guards, and heat shields are installed correctly. During machine operation, this action will help to prevent vibration, rubbing against other parts, excessive heat, and failure of lines, tubes, and hoses.

Do not operate a machine when a fire hazard exists. Repair any lines that are corroded, loose, or damaged. Leaks may provide fuel for fires. Consult your Hyundai Heavy Industries dealer for repair or for replacement parts.

Ether

Ether (if equipped) is commonly used in cold weather applications. Ether is flammable and poisonous.

Do not spray ether manually into an engine if the machine is equipped with a thermal starting aid for cold weather starting.

Use ether in ventilated areas. Do not smoke while you are replacing an ether cylinder or while you are using an ether spray.

Do not store ether cylinders in living areas or in the operator compartment of a machine. Do not store ether cylinders in direct sunlight or in temperatures above 49°C(120.2 °F). Keep ether cylinders away from unauthorized personnel.

Avoid traveling in a cross direction on a slope as it can cause the danger of rolling over and sliding.

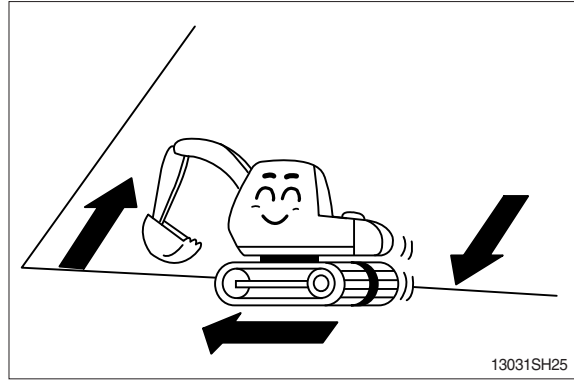

Traveling on a slope is dangerous. Be sure to operate slowly when traveling down a slope and maintain the bucket at a height of 20~30 cm (1 ft) above the ground so that it can be used as brake in an emergency.

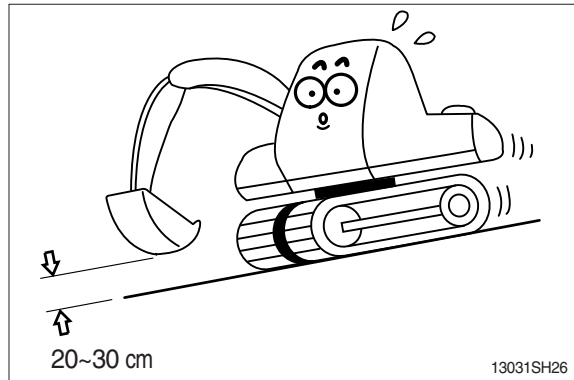

Steering of the machine while traveling on a slope is dangerous. When an inevitable turning of direction is required, turn on the flat and solid ground.

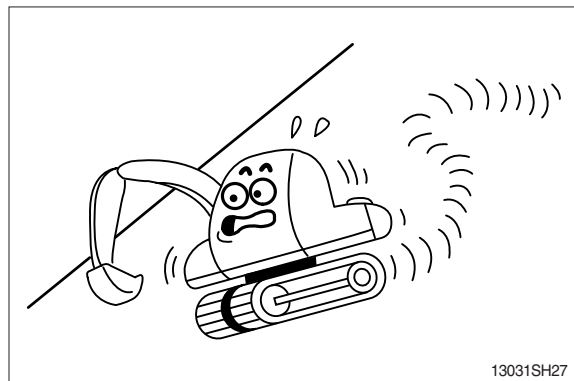

The engine angularity limits are 35 degree. Do not operate by more than the engine limits in any case.

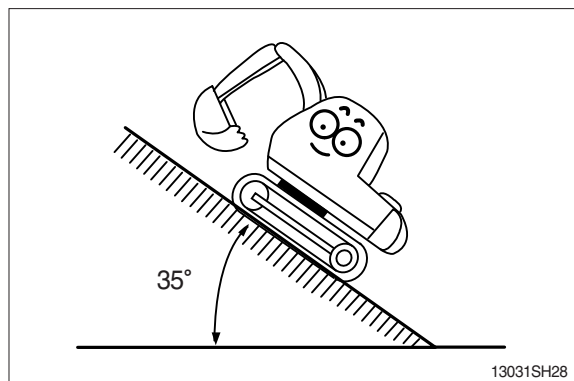

3) R260LC-9A HIGH WALKER

· 5.85 m (19' 2") BOOM and 3.05 m (10' 0") ARM

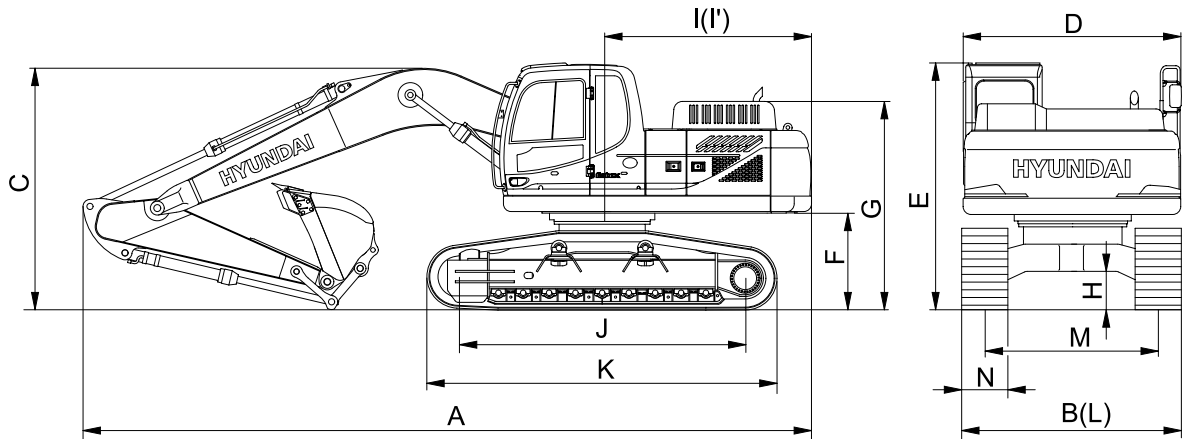

2609A2SP04

Description		Unit	Specification
Operating weight		kg (lb)	27450 (60520)
Bucket capacity (SAE heaped), standard		m ³ (yd ³)	1.08 (1.41)
Overall length	A	mm (ft-in)	9760 (32' 0")
Overall width, with 600 mm shoe	B		3390 (11' 1")
Overall height	C		3240 (10' 8")
Superstructure width	D		2840 (9' 4")
Overall height of cab	E		3345 (11' 0")
Ground clearance of counterweight	F		1470 (4' 10")
Engine cover height	G		2896 (9' 6")
Minimum ground clearance	H		765 (2' 6")
Rear-end distance	I		2870 (9' 5")
Rear-end swing radius	I'		2975 (9' 9")
Distance between tumbler	J		4030 (13' 3")
Undercarriage length	K		4940 (16' 2")
Undercarriage width	L		3390 (11' 1")
Track gauge	M		2790 (9' 2")
Track shoe width, standard	N		600 (24")
Travel speed (low/high)			km/hr (mph)
Swing speed		rpm	11.6
Gradeability		Degree (%)	35 (70)
Ground pressure (600 mm shoe)		kgf/cm ² (psi)	0.53 (7.54)
Max traction force		kg (lb)	21600 (47600)

7. UNDERCARRIAGE

1) TRACKS

X-leg type center frame is integrally welded with reinforced box-section track frames. The design includes dry tracks, lubricated rollers, idlers, sprockets, hydraulic track adjusters with shock absorbing springs and assembled track-type tractor shoes with triple grousers.

2) TYPES OF SHOES

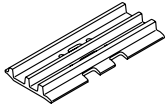
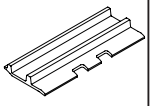
Model	Shapes		Triple grouser				Double grouser
							
R260LC-9A	Shoe width	mm (in)	600 (24)	700 (28)	800 (32)	900 (36)	-
	Operating weight	kg (lb)	25200 (55600)	25500 (56200)	25800 (56900)	26100 (57500)	-
	Ground pressure	kgf/cm ² (psi)	0.51 (7.25)	0.44 (6.26)	0.39 (5.55)	0.35 (4.98)	-
	Overall width	mm (ft-in)	3180 (10' 5")	3280 (10' 9")	3380 (11' 1")	3480 (11' 5")	-
R260NLC-9A	Shoe width	mm (in)	600 (24)	-	-	-	-
	Operating weight	kg (lb)	25100 (55300)	-	-	-	-
	Ground pressure	kgf/cm ² (psi)	0.51 (7.25)	-	-	-	-
	Overall width	mm (ft-in)	2980 (9' 9")	-	-	-	-
R260LC-9A HIGH WALKER	Shoe width	mm (in)	600 (24)	700 (28)	800 (32)	-	700 (28)
	Operating weight	kg (lb)	27450 (60520)	28020 (61770)	28400 (62610)	-	28620 (63100)
	Ground pressure	kgf/cm ² (psi)	0.53 (7.54)	0.46 (6.54)	0.41 (5.83)	-	0.47 (6.68)
	Overall width	mm (ft-in)	3180 (10' 5")	3280 (10' 9")	3380 (11' 1")	-	3280 (10' 9")

3) NUMBER OF ROLLERS AND SHOES ON EACH SIDE

Item	Quantity	
	R260LC-9A, R260NLC-9A	R260LC-9A HIGH WALKER
Carrier rollers	2 EA	2 EA
Track rollers	9 EA	9 EA
Track shoes	51 EA	48 EA

(4) Emergency warning lamp



21093CD30

① This lamp pops up and the buzzer sounds when each of the below warnings is happened.

- Engine coolant overheating (over 107°C)
- Hydraulic oil overheating (over 105°C)
- Pump EPPR circuit abnormal or open
- Attachment flow EPPR circuit abnormal or open
- MCU input voltage abnormal
- Accel dial circuit abnormal or open
- Cluster communication data error
- Engine ECM communication data error

※ **The pop-up warning lamp moves to the original position and blinks when the select switch is pushed. Also the buzzer stops. This is same as following warning lamps.**

② When this warning lamp blinks, machine must be checked and serviced immediately.

(5) Engine oil pressure warning lamp

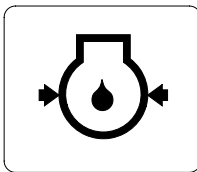

21093CD32

① This lamp blinks when the engine oil pressure is low.

② If the lamp blinks, shut OFF the engine immediately. Check oil level.

(6) Check engine warning lamp

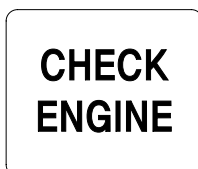

21093CD33

①

②

③

※

(7) Battery charging warning lamp

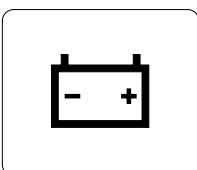

This lamp blinks when the battery charging voltage is low. Check the battery charging circuit when this lamp blinks.

(2) Mode setup

① Work tool

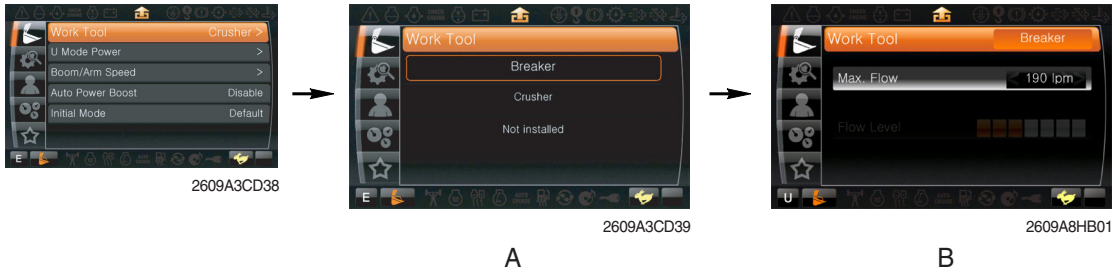

- A : Select one installed optional attachment.
- B : Max flow - Set the maximum flow for the attachment.
 Flow level - Reduce the operating flow from maximum flow.
 Breaker - Max 7 steps, Reduced 10 lpm each step.
 Crusher - Max 4 steps, Reduced 20 lpm each step.

※ The flow level is displayed with the work mode pilot lamp.

② U mode power



- Engine high idle rpm, auto idle rpm and pump torque (power shift) can be modulated and memorized separately in U-mode.
- U-mode can be activated by user mode switch.

Step (I)	Engine speed (rpm)	Idle speed (rpm)	Power shift (bar)
1	1500	700	0
2	1550	800	3
3	1600	900	6
4	1650	1000 (auto decel)	9
5	1700	1050	12
6	1750	1100	16
7	1800	1150	20
8	1850	1200	26
9	1900	1250	32
10	1950	1300	38

※ One touch decel & low idle : 850rpm

③ Boom/Arm speed



- **Boom speed**
 - Control type
 Manual - Boom up speed is fixed as set steps.
 Auto - Boom up speed is automatically adjusted as working conditions by the MCU.
 - Speed setting - Boom up speed is increased as much as activated steps.
- **Arm speed**
 - Regeneration - Arm regeneration function can be activated or cancelled.
 Enable - Arm in speed is up.
 Disable - Fine operation.

② Tripmeter

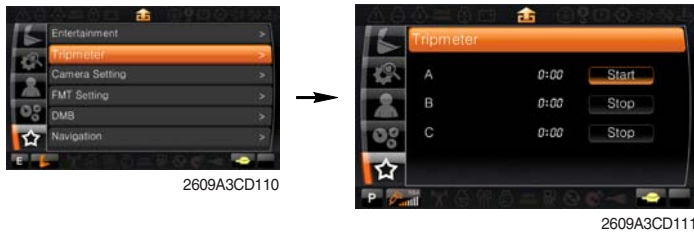

- Maximum 3 kinds of tripmeters can be used at the same time.
- Each tripmeter can be turned on by choosing "Start" while it also can be turned off by choosing "Stop".
- If the tripmeter icon is activated in the operation screen, it can be controlled directly there.

③ Camera setting

- Three cameras can be installed on the machine and the display order can be set by this menu.
- If the camera was not equipped, this menu is not useful.



- Turning the select switch in clockwise direction, the next ordered will be shown and in counter-clockwise direction, the previously ordered will be shown.
- Push the select switch, the displayed screen will be enlargement.



1) POWER OFF SWITCH

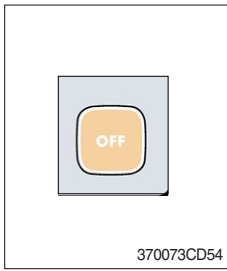

- (1) This switch makes the system and the LED OFF.
Just before the power OFF, set values are stored.

(2) Default setting values

Function	Air conditioner	In/outlet	LCD	Temperature	Mode
Value	OFF	Inlet	OFF	Previous sw OFF	Previous sw OFF

2) AUTO SWITCH

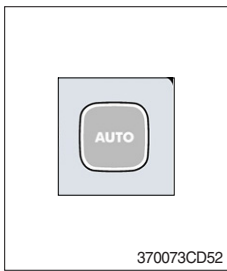

- (1) Turn the starting switch to ON position, LCD lights ON.
Auto air conditioner and heater system automatically keeps the optimum condition in accordance with operator's temperature configuration sensing ambient and cabin inside temperature.

- (2) This switch can restart system after system OFF.

3) AIR CONDITIONER SWITCH (compressor switch)

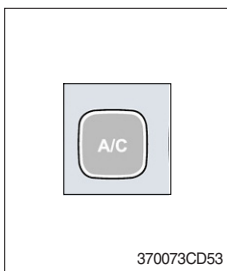

- (1) This switch turns the compressor and the LCD ON.
- (2) In accordance with the temperature sensed by duct (evaporator) sensor, compressor turns ON or OFF automatically.
- ※ **Air conditioner operates to remove vapor and drains water through a drain hose. Water can be sprayed into the cab in case that the drain cock at the ending point of drain hose has a problem.**

In this case, exchange the drain cock.

4) FAN SPEED SWITCH

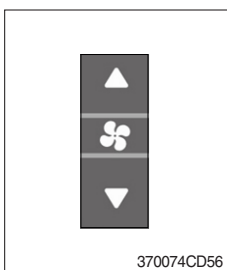

- (1) Fan speed is controlled automatically by setted temperature.
- (2) This switch controls fan speed manually.
- There are 8 up/down steps to control fan speed.
 - The maximum step or the minimum step beeps 5 times.
- (3) This switch makes the system ON.

CLICK HERE TO **DOWNLOAD** THE COMPLETE MANUAL

- Thank you very much for reading the preview of the manual.
- You can download the complete manual from: www.heydownloads.com by clicking the link below



- Please note: If there is no response to CLICKING the link, please download this PDF first and then click on it.

CLICK HERE TO **DOWNLOAD** THE COMPLETE MANUAL

4) RADIO AND USB PLAYER

■ BASIC FUNCTIONS

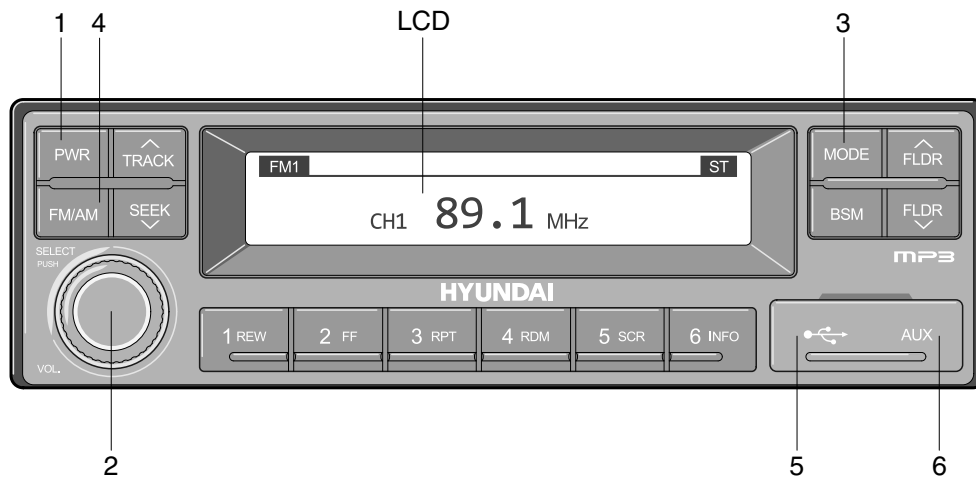

2209S3CD70

- | | |
|-------------------------------|----------------------------------|
| 1 Power (PWR) button | 4 Radio (FM/AM) selection button |
| 2 Volume/Sound setting button | 5 USB slot |
| 3 Mode selection button | 6 AUX terminal |

(1) Power (PWR) button

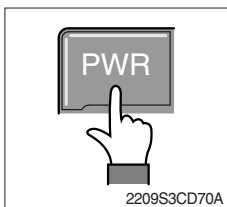

- ① Press the PWR button to turn on the audio. While the audio is operating, press the button to turn the power off.

(2) Volume/Sound setting button

· Volume (VOL) button

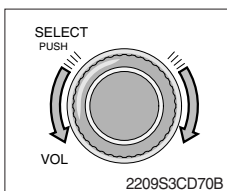

- ① Turn the VOL button clockwise to increase the volume and counter-clockwise to decrease the volume.

(3) FF/REW button

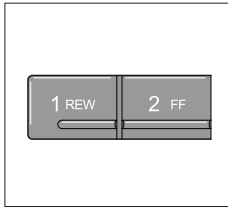

While an iPod is operating, press and hold the FF button to fast-forward the song.

When fast-forward is complete, the next song will properly play from the beginning even if you continue holding the button. Press and hold the REW button to rewind the song.

When rewind is complete, the current song will properly play from the beginning even if you continue holding the button.

Shortly pressing the buttons will not operate the FF/REW.

(4) Repeat (RPT) button

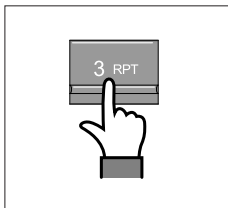

While music is playing, press the RPT button to repeat the currently playing song.

(5) Random play (RDM) button

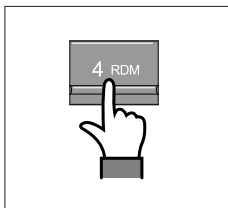

While music is playing, press the RDM button to randomly play the songs.

(6) Scroll (SCR) button

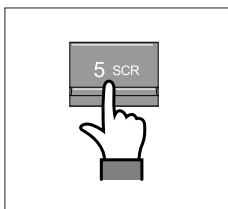

Displays the file name of the currently playing song on the LCD. Here, the SCR button turns the file name SCROLL ON/OFF.

(7) View music info (INFO) button

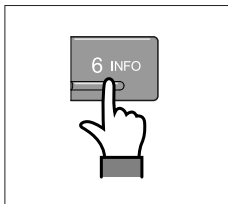

Each time the INFO button is pressed, the info on the currently playing song will be displayed in order of ARTIST → ALBUM → TITLE.

3) STARTING ENGINE IN COLD WEATHER

- ※ Sound horn to warn surroundings after checking if there are obstacles in the area.
- ※ Replace the engine oil and fuel referring to recommended oils at page 2-19.
- ※ Fill the anti-freeze solution to the coolant as required.
- ※ If you turn ON the starting switch, the fuel warmer is automatically operated to heat the fuel by sensing the coolant temperature.

- (1) Check if all the levers are in the neutral position.
- (2) Turn the accel dial switch to low idle position.
- (3) Turn the starting switch to the ON position, and wait 1~2 minutes. More time may take according to ambient temperature.
- (4) Wait for five minutes to warm up the engine after the preheating pilot lamp off, and then turn the starting switch to the START position to start the engine.
 - ※ If the engine does not start, allow the starter to cool for about 2 minutes before attempting to start the engine again.
- (5) Release the starting switch immediately after starting engine.
- (6) If the temperature of the coolant is lower than 30°C the warming up automatically starts.
 - ※ Do not operate the working devices, or convert the operation mode into other mode during the warming up.

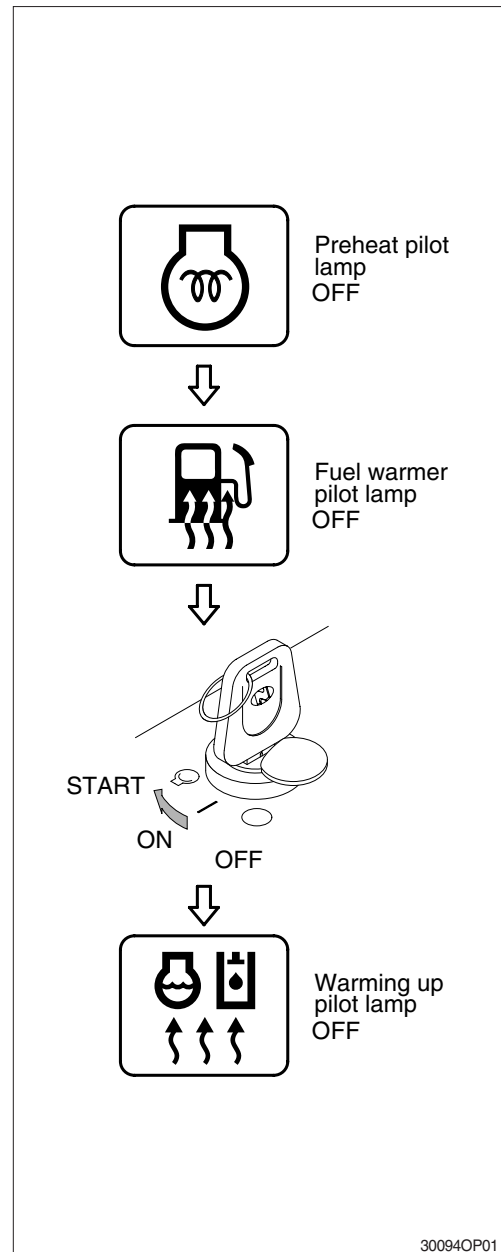

2) TRAVELING ON A SLOPE

- (1) Make sure that the travel lever is properly maneuvered by confirming the travel motor is in the right location.
 - (2) Lower the bucket 20 to 30 cm (1 ft) to the ground so that it can be used as a brake in an emergency.
 - (3) If the machine starts to slide or loses stability, lower the bucket immediately and brake the machine.
 - (4) When parking on a slope, use the bucket as a brake and place blocks behind the tracks to prevent sliding.
- ※ Machine cannot travel effectively on a slope when the oil temperature is low. Do the warming-up operation when it is going to travel on a slope.
- ▲ Be careful when working on slopes. It may cause the machine to lose its balance and turn over.
- ▲ Be sure to keep the travel speed switch on the LOW (turtle mark) while traveling on a slope.

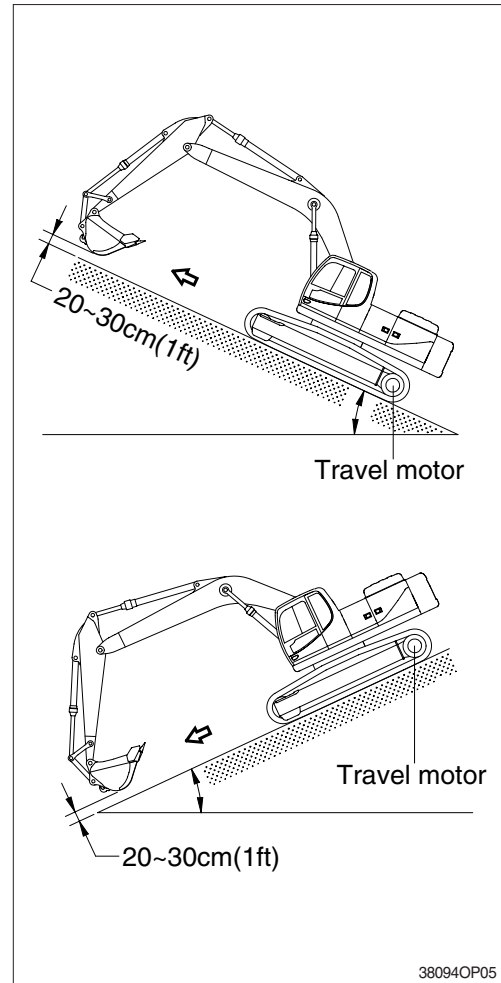

3) TRAVELING ON SOFT GROUND

- ※ If possible, avoid to operate on soft ground.
- (1) Move forward as far as machine can move.
 - (2) Take care not to go beyond the depth where towing is impossible on soft ground.
 - (3) When driving becomes impossible, lower bucket and use boom and arm to pull the machine. Operate boom, arm, and travel lever at the same time to avoid the machine sinking.

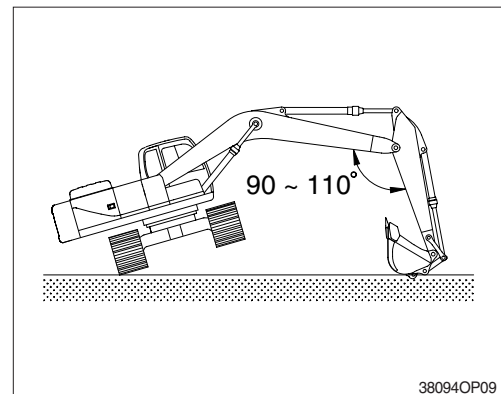

11. STORAGE

Maintain the machine taking care of following to prevent the deterioration of machine when storing the machine for a long time, over 1 month.

1) BEFORE STORAGE

(1) Cleaning the machine

Clean the machine. Check and adjust tracks.
Grease each lubrication part.

(2) Lubrication position of each part

Change all oil.

※ **Be particularly careful when you reuse the machine.**

As oil can be diluted during storage.

Apply an anticorrosive lubricant on the exposed part of piston rod of cylinder and in places where the machine rusts easily.

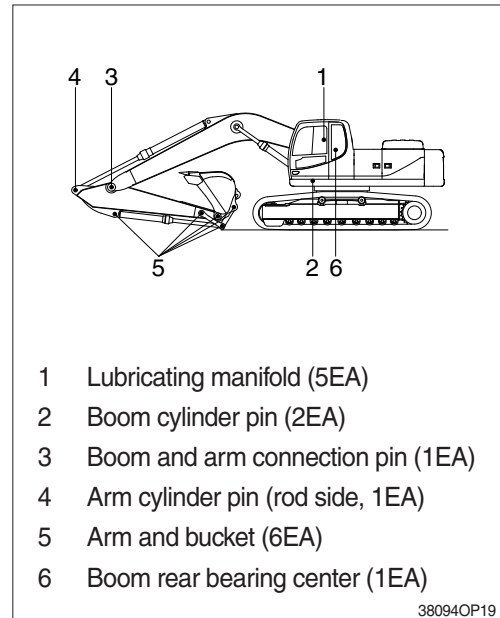

(3) Master switch

Turn OFF the master switch mounted electric box and store the machine.

(4) Be sure to mix anticorrosive antifreezing solution in the radiator.

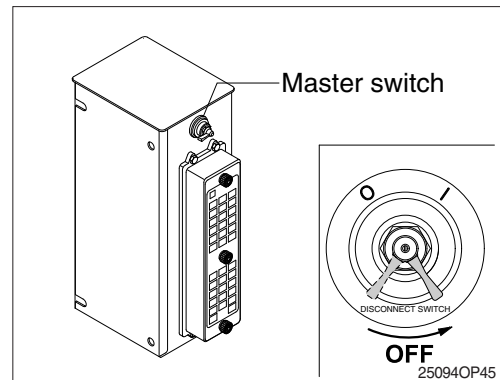

(5) Prevention of dust and moisture

Keep machine dry. Store the machine setting wood on the ground.

- ※ **Cover exposed part of piston rod of cylinder.**
- ※ **Lower the bucket to the ground and set a support under track.**

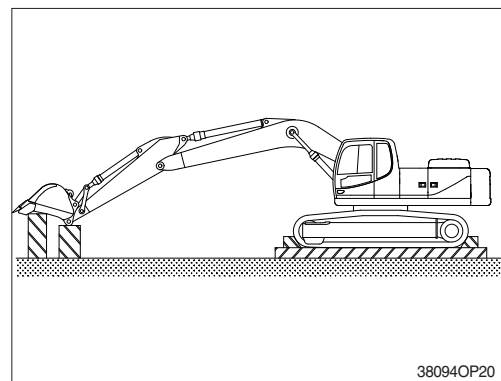

3. LOADING THE MACHINE

- 1) Load and unload the machine on a flat ground.
- 2) Use the gangplank with sufficient length, width, thickness and gradient.
- 3) Place the safety lever to the LOCK position (if equipped) before fixing the machine at the bed of trailer and confirm if the machine parallels the bed of trailer.
Keep the travel motor in the rear when loading and in the front when unloading.

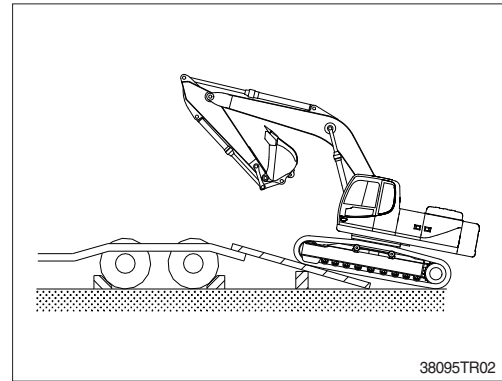

- 4) Do the following after loading the machine to the trailer.
 - (1) Stop loading when the machine is located horizontally with the rear wheel of trailer.

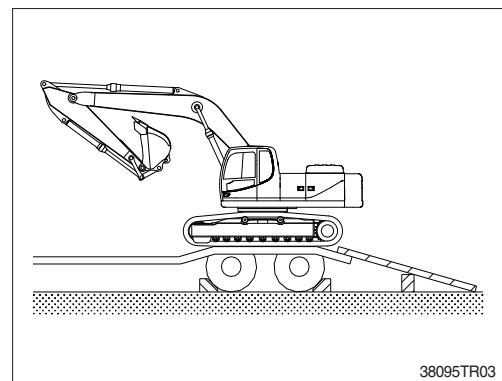

- (2) Place the safety lever to the LOCK position (if equipped) after the swing the machine 180 degree.

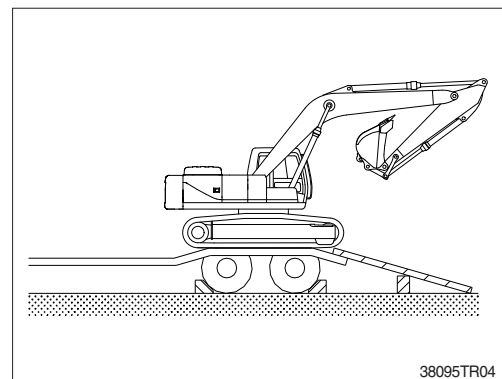

2) PIPE AND HOSE (FLARE type)

Thread size (PF)	Width across flat (mm)	kgf · m	lbf · ft
1/4"	19	4	28.9
3/8"	22	5	36.2
1/2"	27	9.5	68.7
3/4"	36	18	130
1"	41	21	152
1-1/4"	50	35	253

3) PIPE AND HOSE (ORFS type)

Thread size (UNF)	Width across flat (mm)	kgf · m	lbf · ft
9/16-18	19	4	28.9
11/16-16	22	5	36.2
13/16-16	27	9.5	68.7
1-3/16-12	36	18	130
1-7/16-12	41	21	152
1-11/16-12	50	35	253

4) FITTING

Thread size	Width across flat (mm)	kgf · m	lbf · ft
1/4"	19	4	28.9
3/8"	22	5	36.2
1/2"	27	9.5	68.7
3/4"	36	18	130
1"	41	21	152
1-1/4"	50	35	253

Service interval	No.	Description	Service action	Oil symbol	Capacity l (U.S.gal)	Service points No.
10 Hours or daily	1	Hydraulic oil level	Check, Add	HO	165 (43.6)	1
	2	Engine oil level	Check, Add	EO	23 (6.1)	1
	4	Radiator coolant	Check, Add	C	40 (10.56)	1
	5	Prefilter (water, element)	Check, Clean	-	-	1
	6	Fan belt tension and damage	Check, Adjust	-	-	1
	9	Fuel tank	Check, Refill	DF	400 (105.7)	1
50 Hours or weekly	8	Bucket linkage pins	Check, Add	PGL	-	6
	9	Fuel tank (water, sediment)	Check, Clean	-	-	1
	11	Swing reduction gear case	Check, Add	GO	6.0 (1.6)	1
	14	Track tension	Check, Adjust	PGL	-	2
250 Hours	7	Attachment pins & bushing	Check, Add	PGL	-	11
	10	Swing bearing grease	Check, Add	PGL	-	2
	15	Battery (voltage)	Check	-	-	1
	18	Air breather element	Replace	-	-	1
	21	Aircon and heater fresh air filter	Check, Clean	-	-	1
500 Hours	2	Engine oil	Change	EO	23 (6.1)	1
	3	Engine oil filter	Replace	-	-	1
	5	Prefilter	Replace	-	-	1
	23	Fuel filter element	Replace	-	-	1
	24	Radiator, oil cooler, charge air cooler	Check, Clean	-	-	3
1000 Hours	11	Swing reduction gear case	Change	GO	6.0 (1.6)	1
	12	Swing reduction gear grease	Change	PGL	1.5 (0.4)	1
	13	Swing gear and pinion grease	Change	PGL	9.0 kg (19.8 lb)	1
	16	Hydraulic oil return filter	Replace	-	-	1
	17	Drain filter cartridge	Replace	-	-	1
	20	Pilot line filter element	Replace	-	-	1
	22	Air cleaner element (primary)	Check, Clean	-	-	1
	25	Travel reduction gear case	Change	GO	6.0 (1.6)	2
	25	Travel reduction gear case (high walker)	Change	GO	8.0 (2.1)	2
2000 Hours	1	Hydraulic oil * ¹	Change	HO	165 (43.6)	1
	4	Radiator coolant	Change	C	40 (10.56)	1
	19	Hydraulic oil suction strainer	Check, Clean	-	-	1
	26	Crankcase breather filter	Replace	-	-	1
	-	Hoses, fittings, clamps (fuel, coolant, hydraulic)	Check, Retighten, Replace	-	-	-
4000 Hours	22	Air cleaner element (primary, safety)	Replace	-	-	2
5000 Hours	1	Hydraulic oil * ²	Change	HO	165 (43.6)	1
	27	DPF (diesel particulate filter)	Clean	-	-	1
As required	21	Aircon & heater fresh filter	Replace	-	-	1
	21	Aircon & heater recirculation filter	Clean, Replace	-	-	1
	22	Air cleaner element (primary)	Clean, Replace	-	-	1
	22	Air cleaner element (safety)	Replace	-	-	1

*¹ Conventional hydraulic oil

*² Hyundai genuine long life hydraulic oil

※ Oil symbol

Please refer to the recommended lubricants for specification.

DF : Diesel fuel

GO : Gear oil

HO : Hydraulic oil

C : Coolant

PGL : Grease

EO : Engine oil

11) FUEL TANK

- (1) Fill fuel fully when system the operation to minimize water condensation, and check it with fuel gauge before starting the machine.
 - (2) Drain the water and sediment in the fuel tank by opening the drain cock.
 - ※ Be sure to LOCK the cap of fuel tank.
 - ※ Remove the strainer of the fuel tank and clean it if contaminated.
- ▲ Stop the engine when refueling.**
All lights and flames shall be kept at a safe distance while refueling.

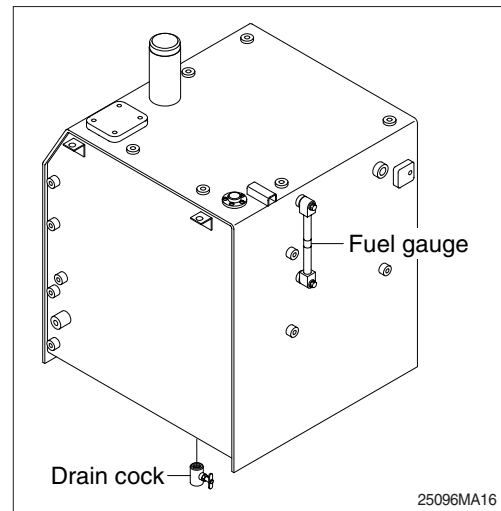

12) PREFILTER

- ※ Inspect or drain the collection bowl of water daily and replace the element every 500hours.

(1) Drain water

- ①
- ②

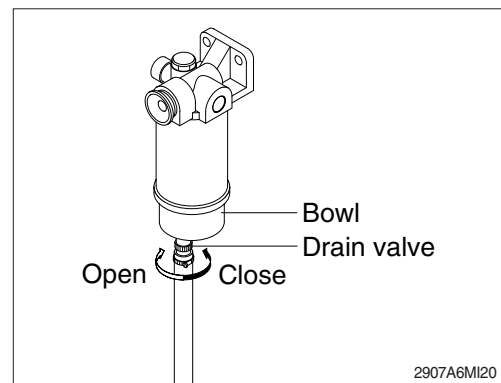

(2) Replace element

- ① Drain the unit of fuel. Follow "Drain water" instructions above.
- ② Remove element, fuel warmer and bowl from filter head.
 - ※ **The bowl is reusable, do not damage or discard.**
- ③ Separate element from bowl. Clean bowl and seal gland.
- ④ Lubricate new bowl seal with clean fuel or motor oil and place in bowl gland.
- ⑤ Attach bowl to new element firmly by hand.
- ⑥ Lubricate new element seal and place in element top gland.
- ⑦ Attach the element, fuel warmer and bowl to the head.

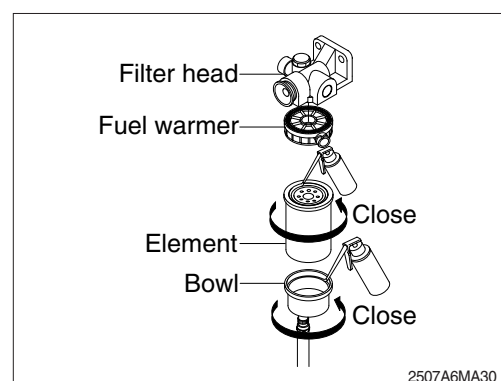
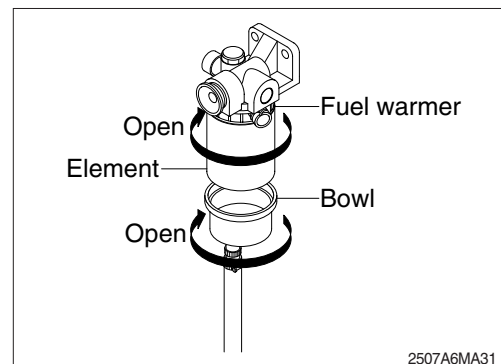

33) LUBRICATE RCV LEVER

Remove the bellows and with a grease gun grease the joint part (A) and sliding parts (B).

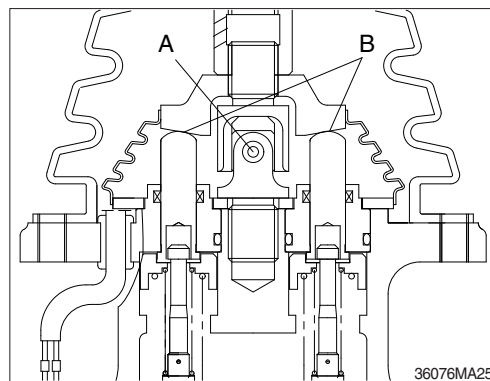

34) ADJUSTMENT OF TRACK TENSION

- ※ It is important to adjust the tension of track properly to extend the lifetime of track and traveling device.
- ※ The wear of pins and bushings on the undercarriage will vary with the working conditions and soil properties.
It is thus necessary to continually inspect the track tension so as to maintain the standard tension on it.

- (1) Raise the chassis with the boom and arm.
 - (2) Measure the distance between bottom of track frame on track center and track of shoe.
- ※ Remove mud with rotating the track before measuring.

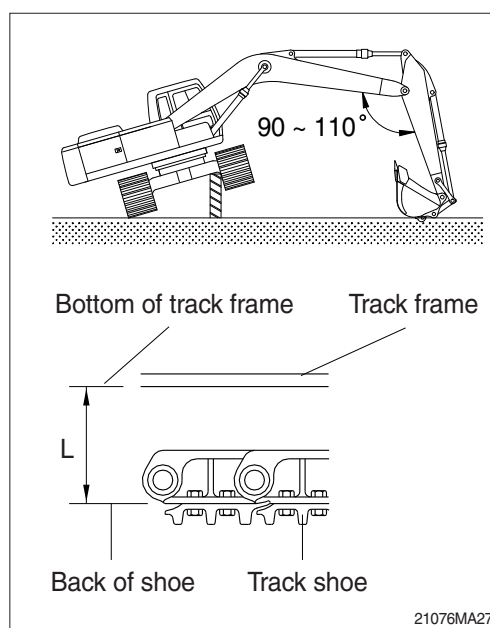

- (3) If the tension is tight, drain the grease in the grease nipple and if the tension is loose, charge the grease.

▲ Personal injury or death can result from grease under pressure.

▲ Unscrew the grease nipple after release the tension by pushing the poppet only when necessarily required.

Grease leaking hole is not existing. So, while unscrew the grease nipple, grease is not leaking until the grease nipple is completely coming out. If the tension is not released in advance, the grease nipple can be suddenly popped out by pressurized grease.

- ※ When the grease is drained, move the track to the forward and backward slightly.

If the track tension is loose even after the grease is charged to the maximum, change the pins and bushings as there are worn seriously.

Length (L)	
300~320 mm	11.8~12.6"

TROUBLESHOOTING GUIDE

1. ENGINE

※ This guide is not intended to cover every conditions, however many of the more common possibilities are listed.

Trouble	Service	Remark
The engine oil pressure lamp lights ON when engine speed is raised after completion of warm up.	<ul style="list-style-type: none"> • Add the oil to the specified level. • Replace the oil filter cartridge. • Check oil leakage from the pipe or the joint. • Replace the monitor. 	
Steam is emitted from the top part of the radiator (the pressure valve). Coolant level warning lamp lights ON.	<ul style="list-style-type: none"> • Supply the coolant and check leakage. • Adjust fan belt tension. • Wash out inside of cooling system. • Clean or repair the radiator fin. • Check the thermostat. • Tighten the radiator cap firmly or replace the packing of it. • Replace the monitor. 	
The engine does not start when the starting motor is turned over.	<ul style="list-style-type: none"> • Add fuel. • Repair where air is leaking into fuel system. • Check the injection pump or the nozzle. • Check the valve clearance. • Check engine compression pressure. • In cold weather, check if fuel warmer system is working normal. 	Refer to the pages 3-27 and 4-4.
Exhaust gas is white or blue.	<ul style="list-style-type: none"> • Adjust to specified oil quantity. • Replace with specified fuel. 	
Exhaust gas occasionally turns black.	<ul style="list-style-type: none"> • Clean or replace the air cleaner element. • Check the nozzle. • Check engine compression pressure. • Clean or replace the turbocharger. 	
Combustion noise occasionally changes to breathing sound.	<ul style="list-style-type: none"> • Check the nozzle. 	
Unusual combustion noise or mechanical noise.	<ul style="list-style-type: none"> • Check with specified fuel. • Check over-heating • Replace the muffler. • Adjust valve clearance. 	

CLICK HERE TO **DOWNLOAD** THE COMPLETE MANUAL

- Thank you very much for reading the preview of the manual.
- You can download the complete manual from: www.heydownloads.com by clicking the link below



- Please note: If there is no response to CLICKING the link, please download this PDF first and then click on it.

CLICK HERE TO **DOWNLOAD** THE COMPLETE MANUAL