

CONTENTS

| | | | |
|--|------|--|------|
| Foreword | 0-1 | 7. Efficient working method | 4-16 |
| Before servicing this machine | 0-2 | 8. Operation in the special work sites | 4-20 |
| EC regulation approved | 0-3 | 9. Normal operation of excavator | 4-22 |
| Table to enter S/No and distribution | 0-4 | 10. Attachment lowering | 4-23 |
| Safety labels | 0-5 | 11. Storage | 4-24 |
| Machine data plate | 0-18 | 12. RCV lever operating pattern | 4-26 |
| Guide (direction, S/No, symbol) | 0-19 | 13. Switching hydraulic attachment circuit | 4-28 |

SAFETY HINTS

| | |
|---------------------------------------|------|
| 1. Before operating the machine | 1-1 |
| 2. During operating the machine | 1-16 |
| 3. During maintenance | 1-23 |
| 4. Parking | 1-26 |

SPECIFICATIONS

| | |
|---|------|
| 1. Major components | 2-1 |
| 2. Specifications | 2-2 |
| 3. Working range | 2-5 |
| 4. Weight | 2-7 |
| 5. Lifting capacities | 2-9 |
| 6. Bucket selection guide | 2-12 |
| 7. Undercarriage | 2-14 |
| 8. Specification for major components | 2-16 |
| 9. Recommended oils | 2-19 |

CONTROL DEVICES

| | |
|-------------------------------------|------|
| 1. Cab devices | 3-1 |
| 2. Cluster | 3-2 |
| 3. Switches | 3-25 |
| 4. Levers and pedals | 3-30 |
| 5. Air conditioner and heater | 3-32 |
| 6. Others | 3-36 |

OPERATION

| | |
|---|------|
| 1. Suggestion for new machine | 4-1 |
| 2. Check before starting the engine | 4-2 |
| 3. Starting and stop the engine | 4-3 |
| 4. Mode selection system | 4-7 |
| 5. Operation of the working device | 4-12 |
| 6. Traveling of the machine | 4-13 |

TRANSPORTATION

| | |
|---|-----|
| 1. Preparation for transportation | 5-1 |
| 2. Dimension and weight | 5-2 |
| 3. Loading the machine | 5-4 |
| 4. Fixing the machine | 5-6 |
| 5. Loading and unloading by crane | 5-7 |

MAINTENANCE

| | |
|---------------------------------------|------|
| 1. Instruction | 6-1 |
| 2. Tightening torque | 6-6 |
| 3. Fuel, coolant and lubricants | 6-9 |
| 4. Maintenance check list | 6-11 |
| 5. Maintenance chart | 6-16 |
| 6. Service instruction | 6-18 |
| 7. Electrical system | 6-42 |
| 8. Air conditioner and heater | 6-45 |

TROUBLESHOOTING GUIDE

| | |
|----------------------------|-----|
| 1. Engine | 7-1 |
| 2. Electrical system | 7-2 |
| 3. Others | 7-3 |

HYDRAULIC BREAKER AND QUICK CLAMP

| | |
|---|-----|
| 1. Selecting hydraulic breaker | 8-1 |
| 2. Circuit configuration | 8-2 |
| 3. Maintenance | 8-3 |
| 4. Precaution while operating the breaker | 8-4 |
| 5. Quick clamp | 8-6 |

| | |
|-------------|-----|
| INDEX | 9-1 |
|-------------|-----|

CLICK HERE TO **DOWNLOAD** THE COMPLETE MANUAL

- Thank you very much for reading the preview of the manual.
- You can download the complete manual from: www.heydownloads.com by clicking the link below



- Please note: If there is no response to CLICKING the link, please download this PDF first and then click on it.

CLICK HERE TO **DOWNLOAD** THE COMPLETE MANUAL

11) **KEEP CLEAR-SIDE** (item 13)

This warning label is positioned on the side of LH rear side cover.

- ▲ To prevent serious personal injury or death keep clear of machine swing radius.
- ▲ Do not deface or remove this label from the machine.

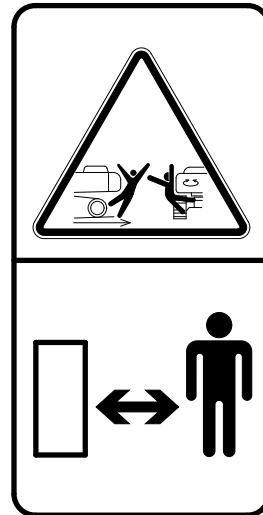

21070FW13

12) **STAY FIX** (item 14)

This warning label is positioned on the side cover.

- ▲ Be sure to support the stay when the door needs to be opened.
- ▲ Be careful that the opened door may be closed by the external or natural force like strong wind.

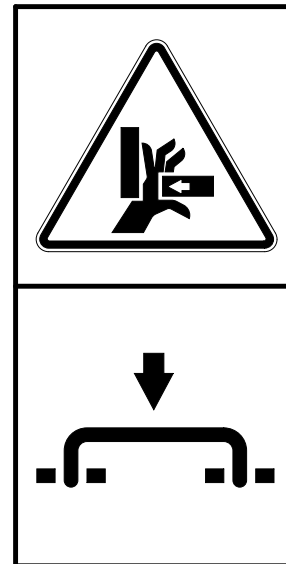

21070FW14

13) **SHEARING-ENGINE HOOD** (item 15)

This warning label is positioned on the engine hood.

- ▲ Do not open the engine hood during the engine's running.
- ▲ Do not touch exhaust pipe or it may cause severe burn.

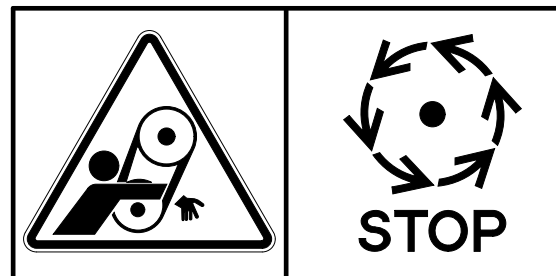

21070FW15

GUIDE

1. DIRECTION

The direction of this manual indicate forward, backward, right and left on the standard of operator when the travel motor is in the rear and machine is on the traveling direction.

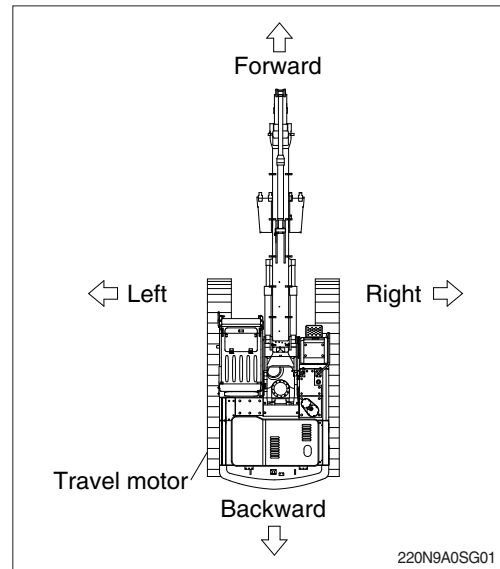

2. SERIAL NUMBER

Inform following when you order parts or the machine is out of order.

1) MACHINE SERIAL NUMBER

The numbers are located below the right window of the operator's cab.

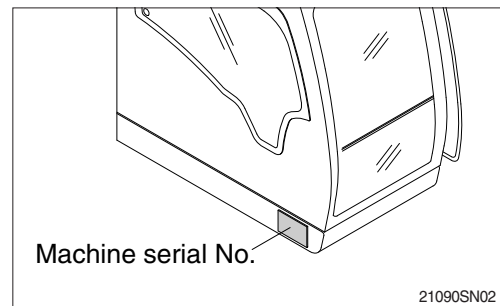

2) ENGINE SERIAL NUMBER

The numbers are located on the engine name plate.

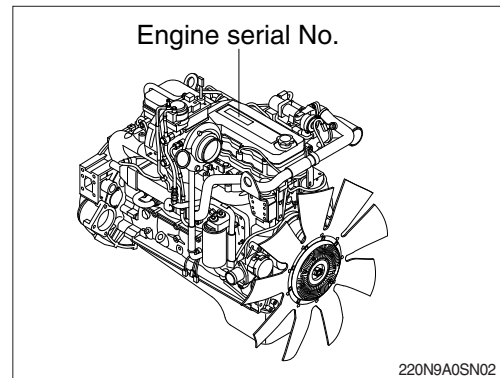

3. INTENDED USE

This machine is designed to be used mainly for the following work.

- Digging work
- Loading work
- Smoothing work
- Ditching work

※ Please refer to the section 4 (efficient working method) further details.

4. SYMBOLS

▲ Important safety hint.

△ It indicates matters which can cause the great loss on the machine or the surroundings.

※ It indicates the useful information for operator.

Lines, Tubes, and Hoses

Do not bend high-pressure lines. Do not strike high-pressure lines. Do not install any lines that are bent or damaged. Use the appropriate backup wrenches in order to tighten all connections to the recommended torque.

Check lines, tubes, and hoses carefully. Wear Personal Protection Equipment (PPE) in order to check for leaks. Always use a board or cardboard when you check for a leak. Leaking fluid that is under pressure can penetrate body tissue. Fluid penetration can cause serious injury and possible death. A pin hole leak can cause severe injury. If fluid is injected into your skin, you must get treatment immediately. Seek treatment from a doctor that is familiar with this type of injury.

Replace the affected parts if any of the following conditions are present :

- End fittings are damaged or leaking.
- Outer coverings are chafed or cut.
- Wires are exposed.
- Outer coverings are swelling or ballooning.
- Flexible parts of the hoses are kinked.
- Outer covers have exposed embedded armoring.
- End fittings are displaced.

Make sure that all clamps, guards, and heat shields are installed correctly. During machine operation, this action will help to prevent vibration, rubbing against other parts, excessive heat, and failure of lines, tubes, and hoses.

Do not operate a machine when a fire hazard exists. Repair any lines that are corroded, loose, or damaged. Leaks may provide fuel for fires. Consult your Hyundai Heavy Industries dealer for repair or for replacement parts.

Ether

Ether (if equipped) is commonly used in cold weather applications. Ether is flammable and poisonous.

Do not spray ether manually into an engine if the machine is equipped with a thermal starting aid for cold weather starting.

Use ether in ventilated areas. Do not smoke while you are replacing an ether cylinder or while you are using an ether spray.

Do not store ether cylinders in living areas or in the operator compartment of a machine. Do not store ether cylinders in direct sunlight or in temperatures above 49°C(120.2 °F). Keep ether cylinders away from unauthorized personnel.

Avoid traveling in a cross direction on a slope as it can cause the danger of rolling over and sliding.

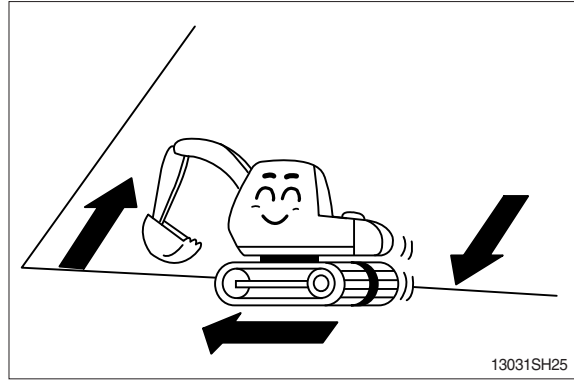

Traveling on a slope is dangerous. Be sure to operate slowly when traveling down a slope and maintain the bucket at a height of 20~30 cm (1 ft) above the ground so that it can be used as brake in an emergency.

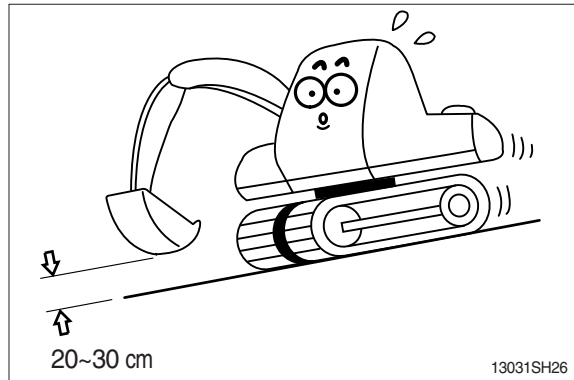

Steering of the machine while traveling on a slope is dangerous. When an inevitable turning of direction is required, turn on the flat and solid ground.

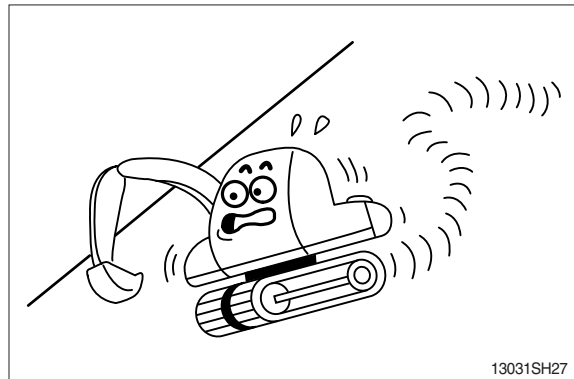

The engine angularity limits are 35 degree. Do not operate by more than the engine limits in any case.

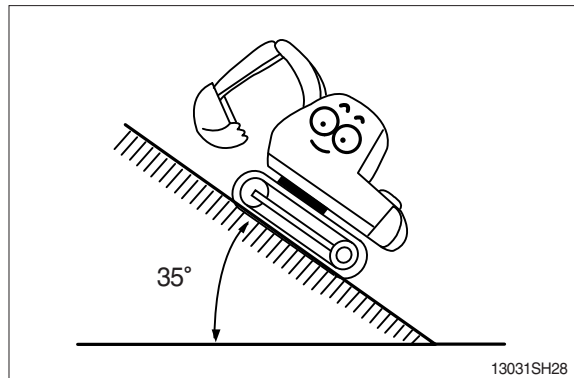

2) 5.65 m (18' 6") HYDRAULIC ADJUSTABLE BOOM

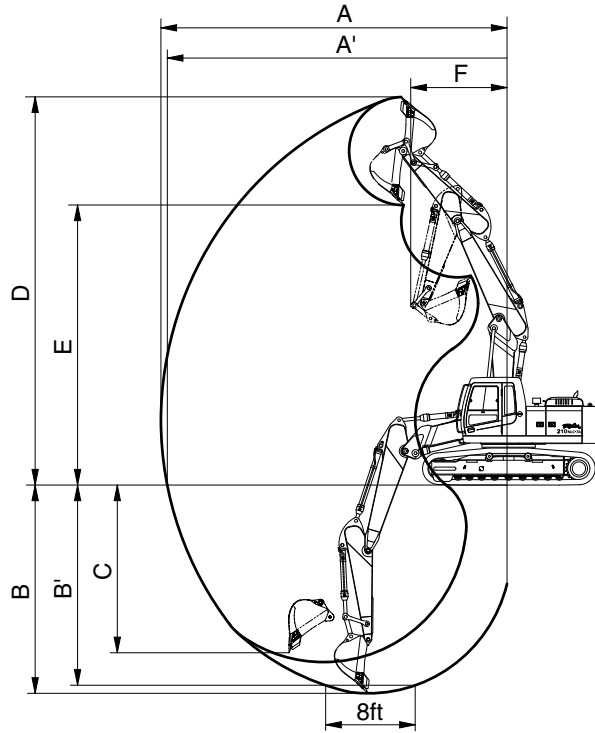

210N7A2SP05

| Description | | 2.0 m (6' 7") Arm | *2.40 m (7' 10") Arm |
|---------------------------------|-----|--------------------|----------------------|
| Max digging reach | A | 9120 mm (29' 11") | 9530 mm (31' 3") |
| Max digging reach on ground | A' | 8940 mm (29' 4") | 9360 mm (30' 9") |
| Max digging depth | B | 5480 mm (18' 0") | 5890 mm (19' 4") |
| Max digging depth (8ft level) | B' | 5360 mm (17' 7") | 5770 mm (18' 11") |
| Max vertical wall digging depth | C | 4560 mm (15' 0") | 4990 mm (16' 4") |
| Max digging height | D | 10300 mm (33' 10") | 10670 mm (35' 0") |
| Max dumping height | E | 7390 mm (24' 3") | 7740 mm (25' 5") |
| Min swing radius | F | 2870 mm (9' 5") | 2670 mm (8' 9") |
| Bucket digging force | SAE | 133 [146] kN | 133 [146] kN |
| | | 13600 [14840] kgf | 13600 [14840] kgf |
| | | 29980 [32710] lbf | 29980 [32710] lbf |
| | ISO | 152 [166] kN | 152 [166] kN |
| | | 15500 [16910] kgf | 15500 [16910] kgf |
| | | 34170 [37280] lbf | 34170 [37280] lbf |
| Arm digging force | SAE | 135 [148] kN | 113 [123] kN |
| | | 13800 [15050] kgf | 11500 [12550] kgf |
| | | 30420 [33190] lbf | 25350 [27650] lbf |
| | ISO | 142 [155] kN | 118 [128] kN |
| | | 14500 [15820] kgf | 12000 [13090] kgf |
| | | 31970 [34880] lbf | 26460 [28870] lbf |

* : Standard [] : Power boost

7) REMOTE CONTROL VALVE

| Item | | Specification |
|-------------------------|------------------|----------------------------------|
| Type | | Pressure reducing type |
| Operating pressure | Minimum | 6.5 kgf/cm ² (92 psi) |
| | Maximum | 25 kgf/cm ² (360 psi) |
| Single operation stroke | Lever(1, 3 port) | 90 mm (3.5 in) |
| | Pedal(2, 4 port) | 130 mm (4.4 in) |

8) CYLINDER

| Item | | Specification | |
|----------------------|-----------------------------|-----------------------------|-------------------------|
| Boom cylinder | Bore dia × Rod dia × Stroke | ∅ 120 × ∅ 85 × 1290 mm | |
| | Cushion | Extend only | |
| Arm cylinder | Bore dia × Rod dia × Stroke | ∅ 140 × ∅ 100 × 1510 mm | |
| | Cushion | Extend and retract | |
| Bucket cylinder | Bore dia × Rod dia × Stroke | ∅ 120 × ∅ 85 × 1055 mm | |
| | Cushion | Extend only | |
| Adjust boom cylinder | 1st | Bore dia × Rod dia × Stroke | ∅ 120 × ∅ 85 × 1290 mm |
| | | Cushion | Extend only |
| | 2nd | Bore dia × Rod dia × Stroke | ∅ 160 × ∅ 100 × 1060 mm |
| | | Cushion | Extend only |

※ Discoloration of cylinder rod can occur when the friction reduction additive of lubrication oil spreads on the rod surface.

※ Discoloration does not cause any harmful effect on the cylinder performance.

8) SHOE

| Item | | Width | Ground pressure | Link quantity | Overall width |
|---------------------------|----------|--------------|-------------------------------------|---------------|------------------|
| R220NLC-9A MONO BOOM | Standard | 500 mm (20") | 0.56 kgf/cm ² (7.96 psi) | 49 | 2500 mm (8' 2") |
| | Option | 600 mm (24") | 0.47 kgf/cm ² (6.68 psi) | 49 | 2600 mm (8' 6") |
| | | 700 mm (28") | 0.41 kgf/cm ² (5.83 psi) | 49 | 2700 mm (8' 10") |
| R220NLC-9A ADJUST BOOM | Standard | 500 mm (20") | 0.56 kgf/cm ² (7.96 psi) | 49 | 2500 mm (8' 2") |
| | Option | 600 mm (24") | 0.48 kgf/cm ² (6.83 psi) | 49 | 2600 mm (8' 6") |

(3) Preheat pilot lamp

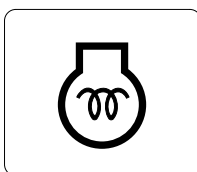

21093CD39

- ① Turning the start key switch ON position starts preheating in cold weather.
- ② Start the engine after this lamp is OFF.

(4) Warming up pilot lamp

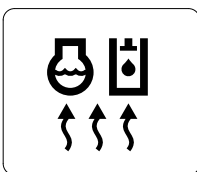

21093CD40

- ① This lamp is turned ON when the coolant temperature is below 30°C (86°F).
- ② The automatic warming up is cancelled when the engine coolant temperature is above 30°C, or when 10 minutes have passed since starting the engine.

(5) Decel pilot lamp

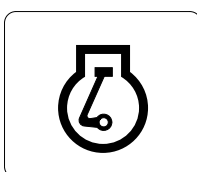

Operating one touch decel switch on the RCV lever makes the lamp ON.

Also, the lamp will be ON and engine speed will be lowered automatically to save fuel consumption when all levers and pedals are at neutral position, and the auto idle function is selected.

One touch decel is not available when the auto idle pilot lamp is turned ON.

Refer to the page 3-28.

(6) Fuel warmer pilot lamp

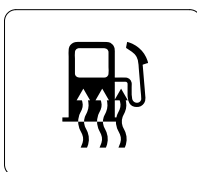

(7) Maintenance pilot lamp

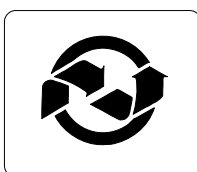

2609A3CD23

- ①
- ②

※ Refer to the page 3-16.

- **Smart key (option)** : Smart key is registered when the operator starts engine by start button first. If smart key is not inside of the cabin, authentication process fails and the password entering is needed.

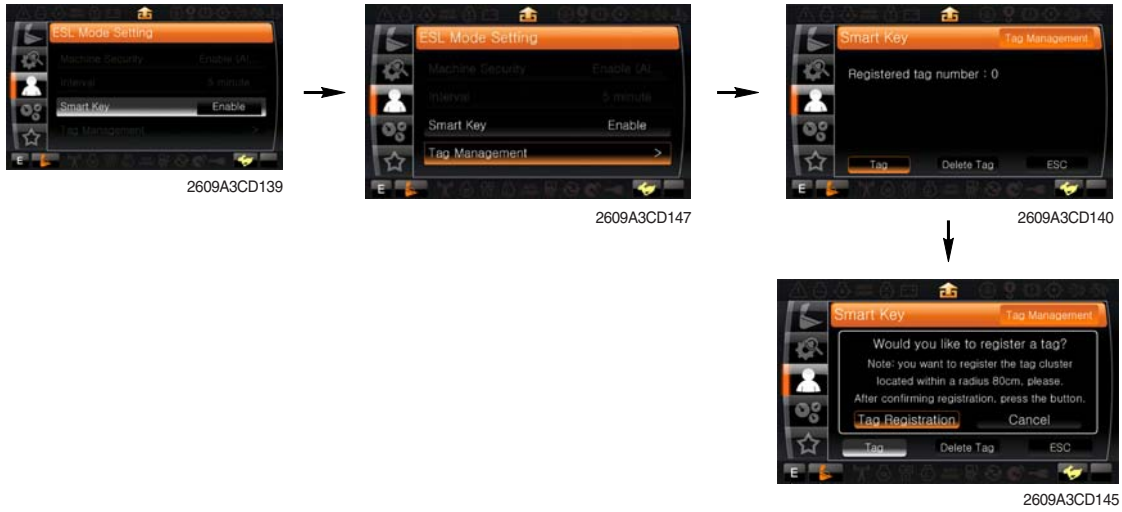

· **Password change**

- The password is 5~10 digits.

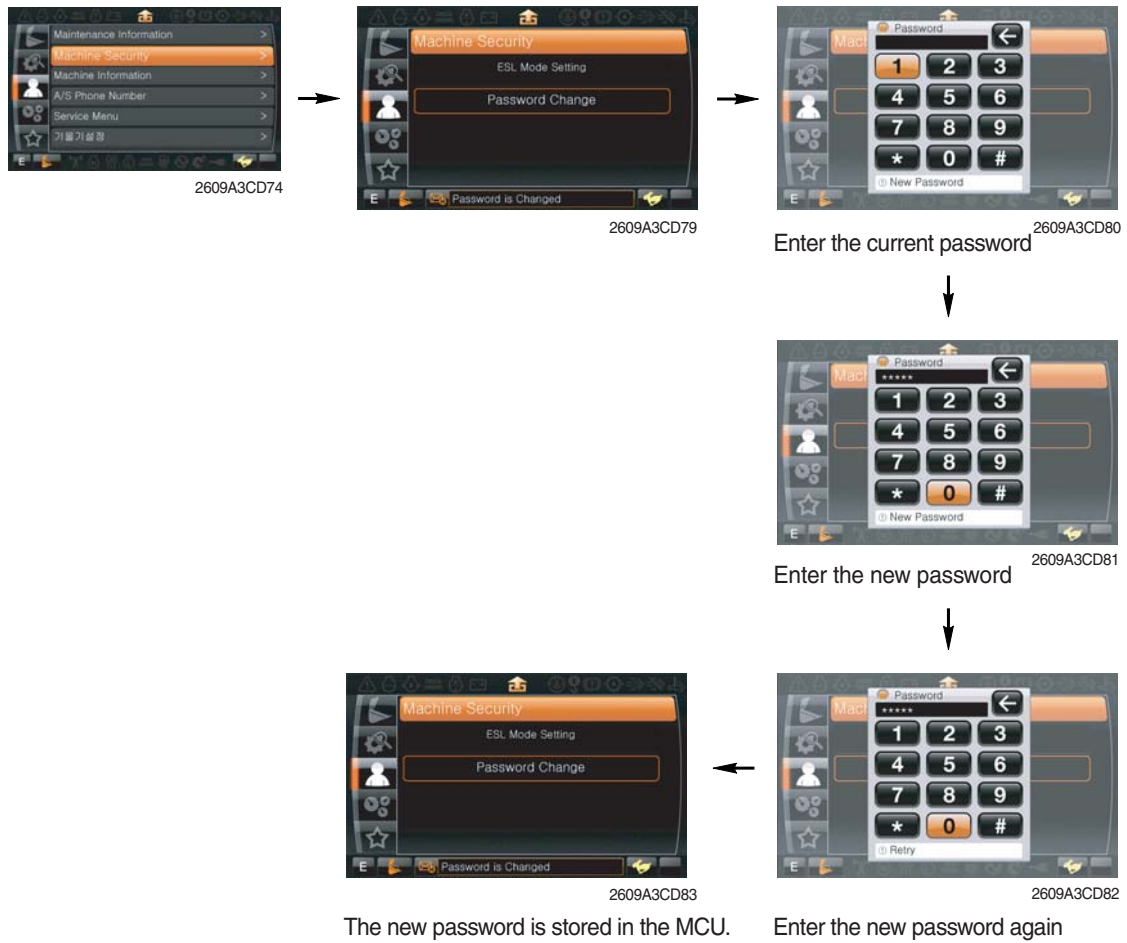

12) HEATED SEAT SWITCH (option)

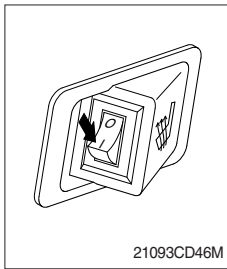

- (1) This switch is used to heat the seat.
 - Heater ON : $10 \pm 3.5^{\circ}\text{C}$
 - Heater OFF : $20 \pm 3^{\circ}\text{C}$
- (2) On pressing the switch, the indicator lamp is turned ON.

13) HORN SWITCH

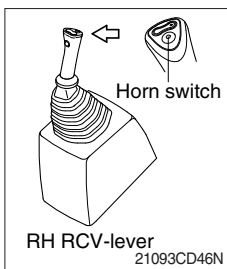

- (1) This switch is at the top of right side control lever.
On pressing, the horn sounds.

14) BREAKER OPERATION SWITCH

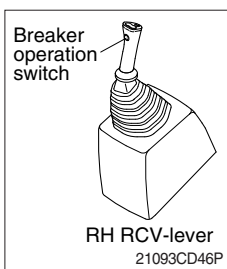

- (1) On pressing this switch, the breaker operates only when the breaker operation mode is selected.

15) ONE TOUCH DECEL SWITCH

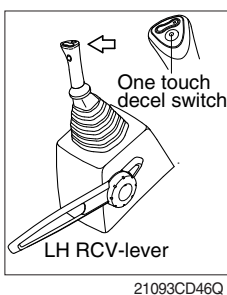

- (1) This switch is used to actuate the deceleration function quickly.
- (2) The engine speed is increased to previous setting value by pressing the switch again.
- (3) One touch decel function is available only when the auto idle pilot lamp is turned OFF.

16) POWER MAX SWITCH

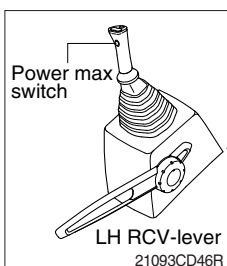

- (1) This switch activate power max function.
When this switch is kept pressed, hydraulic power of work equipment will be increased to approx 110 percent during 8 seconds.
 - (2) After 8 seconds, function is cancelled automatically even the switch keeps pressed.
- ※ **Do not use for craning purposes.**

CLICK HERE TO **DOWNLOAD** THE COMPLETE MANUAL

- Thank you very much for reading the preview of the manual.
- You can download the complete manual from: www.heydownloads.com by clicking the link below



- Please note: If there is no response to CLICKING the link, please download this PDF first and then click on it.

CLICK HERE TO **DOWNLOAD** THE COMPLETE MANUAL

(4) Handsfree jack socket

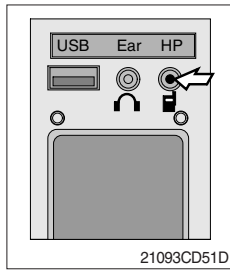

- ① Connect the jack cable when call by handsfree.
- ② Use the special adapter when jack cable is not interchangeable.
- ③ Check the jack type of mobile phone before use.

(5) Indicator lamp

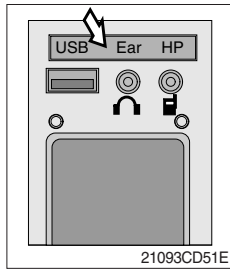

- ① This lamp is turned ON when the handsfree mode selected.

(6) Service socket

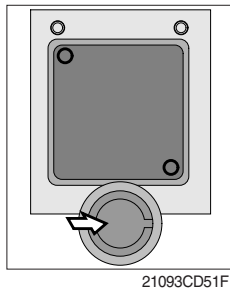

- ① Utilize the power of 12 V as your need and do not exceed power of 12 V, 30 W.

(6) Saving broadcast frequencies to PRESET numbers

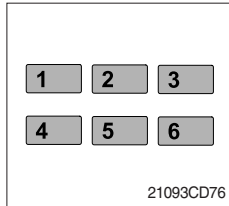

Up to 18 FM broadcasts and 6 AM broadcasts can be saved.

- ① Use the auto/manual search buttons to find the desired frequency.
 - ② Select the preset button (1REW~ 6INFO) to which you wish to save the selected frequency. Press and hold the preset button.
 - ③ The frequency will be saved to the preset button to a sound of a beep. The saved frequency number will be displayed on the LCD DISPLAY. (However, the beep will not sound if the beep function has been turned off in sound setting.)
 - ④ After saving is complete, pressing the preset button will play the corresponding broadcast frequency.
- ※ No beep sound signifies that the preset has not been saved. In this case, try again from the first step. (However, the beep will not sound if the beep function has been turned off in sound setting.)

8) EMERGENCY ENGINE SPEED CONTROL CONNECTOR

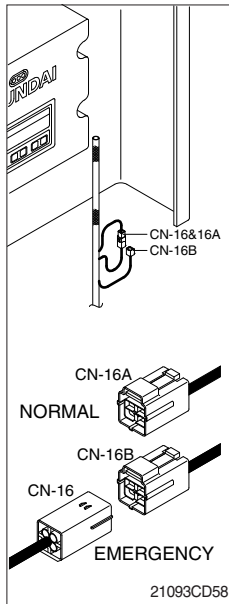

(1) When the CAN communication between the ECM and the MCU is abnormal due to malfunction, change CN-16 connection from CN-16A to CN-16B and then control the engine speed by rotating accel dial switch.

※ **Never connect connector CN-16 with CN-16B when MCU is in normal operation.**

9) SERVICE METER

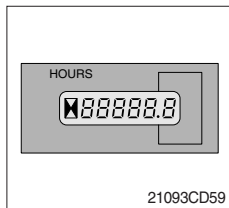

(1) This meter shows the total operation hours of the machine.

(2) Always ensure the operating condition of the meter during the machine operation. Inspect and service the machine based on hours as indicated in chapter 6, maintenance.

10) RS232 & J1939 SERVICE SOCKET

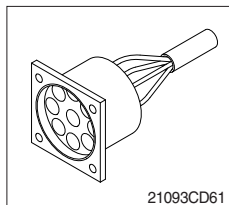

(1) MCU communicates the machine data with Laptop computer through RS232 service socket.

(2) ECM communicates the engine data with cummins INSITE adapter through J1939 service socket.

① ECM fault code check

② ECM program change

③ Engine data monitoring & test

(6) Monitoring system

Information of machine performance as monitored by the MCU can be displayed on the LCD. Refer to the page 3-14.

(7) Self diagnostic system

① MCU (Machine Control Unit)

The MCU diagnoses machine status and problems and displays fault code in the cluster (fault code detected by MCU is composed of HCESPN and FMI).

② Engine ECM (Electronic Control Module)

If the engine or relevant system has problem, engine ECM detects and displays on the LCD as fault codes (this code is composed of SPN and FMI).

※ Refer to the page 3-14 for LCD display.

(8) Anti-restart system

The system protects the starter from inadvertent restarting after the engine is already operational.

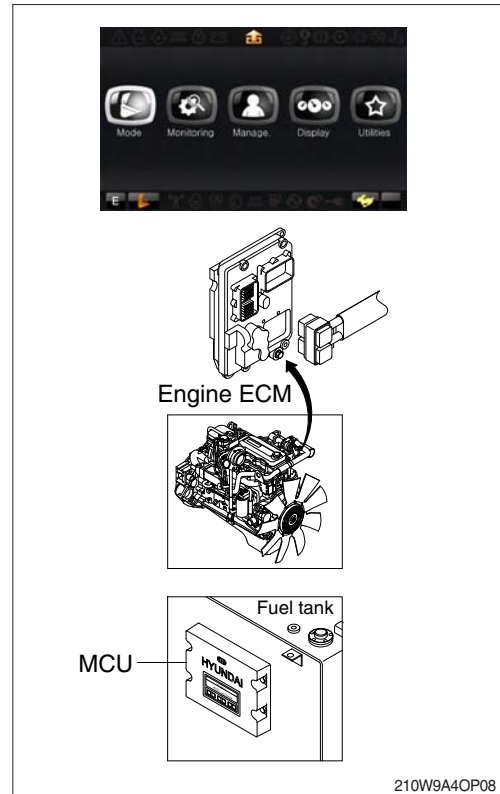

2) HOW TO OPERATE MODE SELECTION SYSTEM

(1) When start key switch is turned ON

- ① When start key switch is turned on, the cluster turns on and buzzer sounds for 4 seconds. And then main information as gauges and engine speed are displayed on LCD.
- ② Initial default mode settings are displayed in the cluster.

| Mode | | Status |
|-------------|--------|--------|
| Power mode | E | ON |
| Work mode | | ON |
| Travel mode | Low () | ON |
| Auto idle | | ON |

※ These setting can be changed at U mode.

- ③ Self-diagnostic function can be carried out from this point.

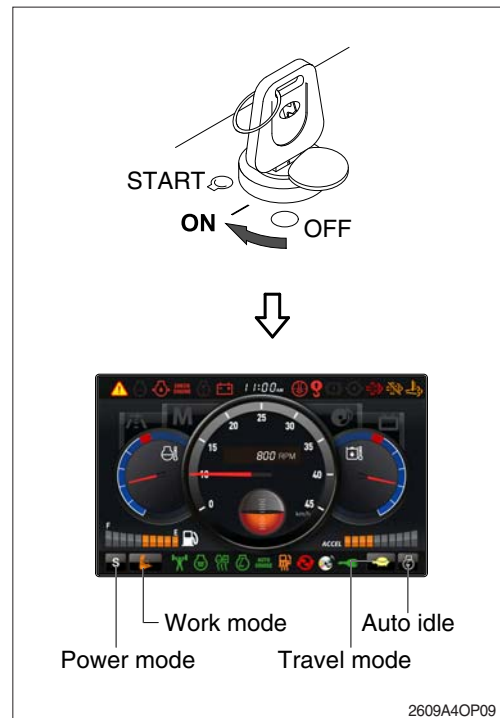

12) BUCKET WITH HOOK

When carrying out lifting work, the special lifting hook is necessary.

The following operations are prohibited.

- Lifting loads with a wire rope fitted around the bucket teeth.
- Lifting loads with the wire rope wrapped directly around the boom or arm.

When performing lifting operation, securely hook the wire rope onto the special lifting hook.

When performing lifting operation, never raise or lower a person.

Due to the possible danger of the load falling or of collision with the load, no persons shall be allowed in the working area.

Before performing lifting operation, designate an operation supervisor.

Always execute operation according to his instructions.

- Execute operating methods and procedures under his direction.
- Select a person responsible for signaling. Operate only on signals given by such person.

Never leave the operator's seat while lifting a load.

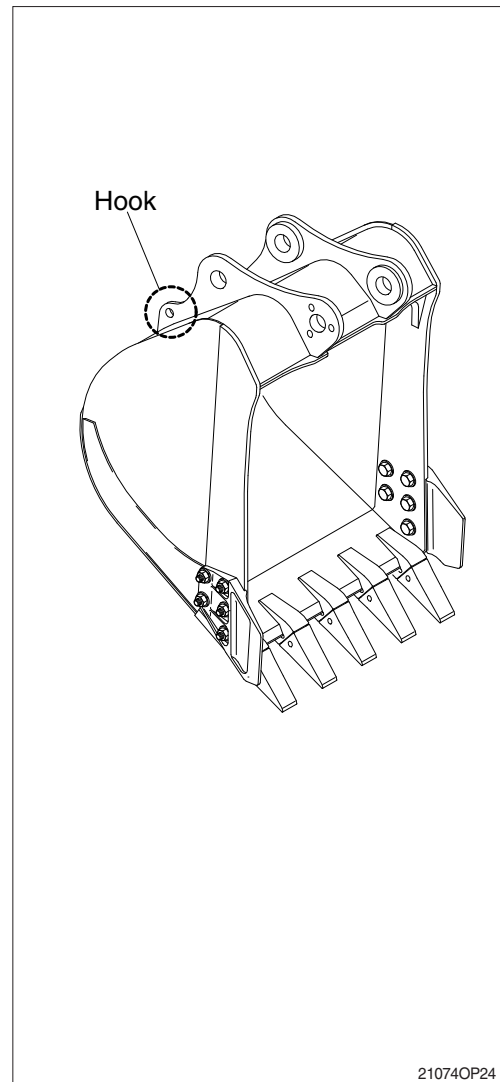

TRANSPORTATION

1. PREPARATION FOR TRANSPORTATION

- 1) When transporting the machine, observe the various road rules, road transportation vehicle laws and vehicle limit ordinances, etc.
- 2) Select proper trailer after confirming the weight and dimension from the chapter 2, specification.
- 3) Check the whole route such as the road width, the height of bridge and limit of weight and etc., which will be passed.
- 4) Get the permission from the related authority if necessary.
- 5) Prepare suitable capacity of trailer to support the machine.

- 6) Prepare gangplank for safe loading referring to the below table and illustration.

| A | B |
|-----|-------------|
| 1.0 | 3.65 ~ 3.85 |
| 1.1 | 4.00 ~ 4.25 |
| 1.2 | 4.35 ~ 4.60 |
| 1.3 | 4.75 ~ 5.00 |
| 1.4 | 5.10 ~ 5.40 |
| 1.5 | 5.50 ~ 5.75 |

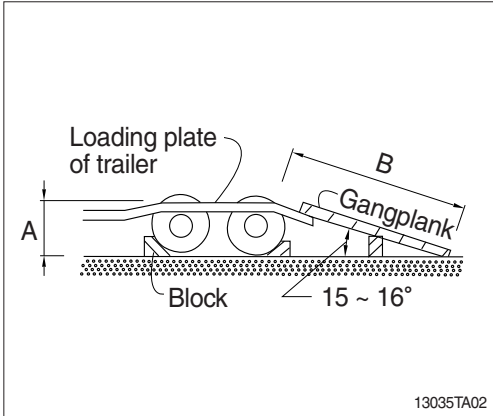
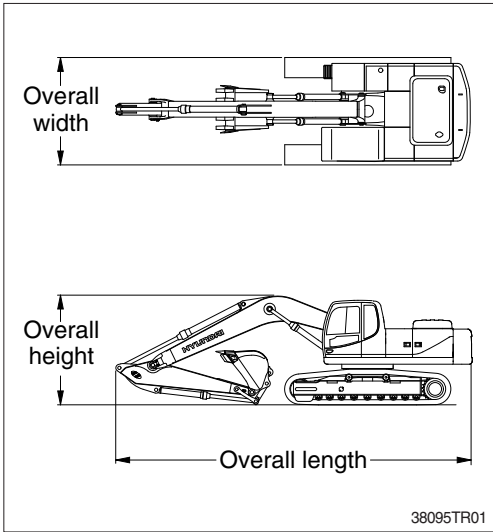

5) PRECAUTION WHEN INSTALLING HYDRAULIC HOSES OR PIPES

- (1) Be particularly careful that the joint of hose, pipe and functioning item are not damaged.
Avoid contamination.
- (2) Assemble after cleaning the hose, pipe and joint of functioning item.
- (3) Use genuine parts.
- (4) Do not assemble the hose in the condition of twisted or sharp radius.
- (5) Keep the specified tighten torque.

8) EVERY 1000 HOURS SERVICE

| Check items | Service | Page |
|---------------------------------|--------------|------|
| Air breather element | Replace | 6-34 |
| Travel motor reduction gear oil | Change | 6-36 |
| Swing reduction gear oil | Change | 6-35 |
| Swing reduction gear grease | Check, Add | 6-35 |
| Grease in swing gear and pinion | Change | 6-35 |
| Hydraulic oil return filter | Replace | 6-33 |
| Drain filter cartridge | Replace | 6-34 |
| Pilot line filter | Replace | 6-34 |
| Air cleaner element (primary) | Check, Clean | 6-26 |

9) EVERY 2000 HOURS SERVICE

| Check items | Service | Page |
|--|---------------------------|------------------|
| Coolant | Change | 6-20, 21, 22, 23 |
| Hydraulic oil * ¹ | Change | 6-32 |
| Hydraulic tank suction strainer | Check, Clean | 6-33 |
| Crankcase breather filter | Replace | 6-29 |
| Hoses, fittings, clamps (fuel, coolant, hydraulic) | Check, Retighten, Replace | - |

*¹ Conventional hydraulic oil

※ **Change oil every 600 hours of continuous hydraulic breaker operation.**

10) EVERY 4000 HOURS SERVICE

| Check items | Service | Page |
|---------------------------------------|---------|------|
| Air cleaner element (primary, safety) | Replace | 6-26 |

11) EVERY 5000 HOURS SERVICE

| Check items | Service | Page |
|------------------------------|---------|------|
| Hydraulic oil * ² | Change | 6-32 |

*² Hyundai genuine long life hydraulic oil

※ **Change oil every 1000 hours of continuous hydraulic breaker operation.**

7) FAN BELT

- (1) A deflection method can be used to check belt tension by applying 11.3 kgf (25 lbf) force between the pulleys on V-belts. If the deflection is more than one belt thickness per foot of pulley center distance, the belt tension must be adjusted.

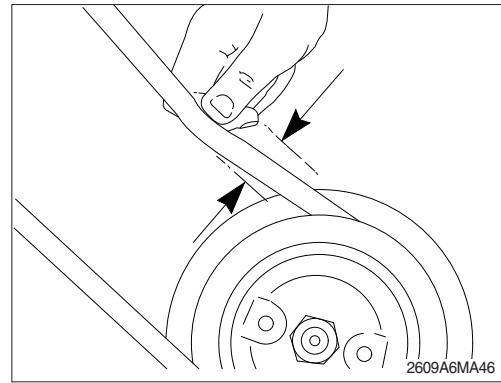

- (2) Inspect the fan belt for damage.

- ① Transverse (across the belt) cracks are acceptable.
- ② Longitudinal (direction of belt ribs) cracks that intersect with transverse cracks are not acceptable.

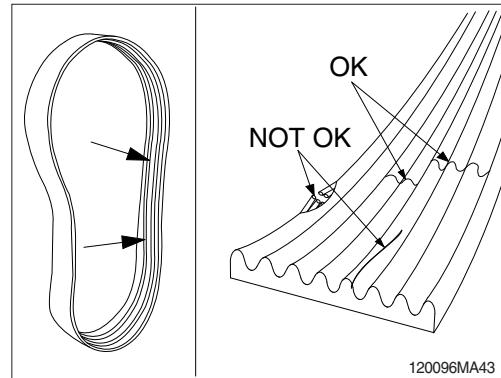

- ③ Inspect the belt

- Embedded debris
- Uneven/excessive rib wear
- Exposed belt cords
- Glazing (high heat)

- ※ If any of the above conditions are present, the belt is unacceptable for reuse and must be replaced.

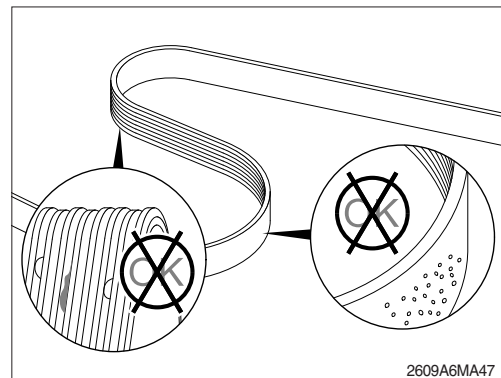

8) INSPECTION OF COOLING FAN

- ▲ Personal injury can result from a fan blade failure. Never pull or pry on the fan. This can damage the fan blade and cause fan failure.

- ※ Rotate the crankshaft by using the engine barring gear.

- ※ A visual inspection of the cooling fan is required daily.

Check for cracks, loose rivets, and bent or loose blades.

Check the fan to make sure it is securely mounted. Tighten the capscrews if necessary. Replace any fan that is damaged.

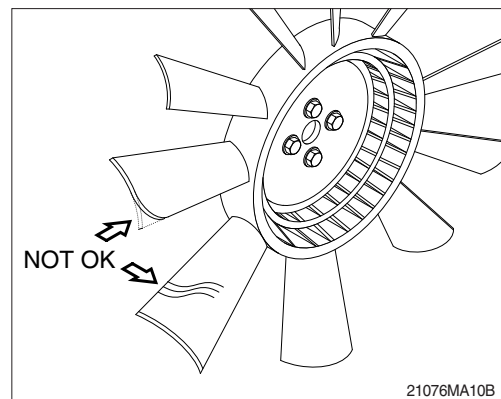

23) REPLACEMENT OF ELEMENT IN HYDRAULIC TANK BREATHER

- (1) Loosen the cap and relieve the pressure in the tank by pushing the top of the air breather.
- (2) Loosen the lock nut and remove the cover.
- (3) Pull out the filter element.
- (4) Replace the filter element new one.
- (5) Reassemble by reverse order of disassembly.
 - Tightening torque : 0.2~0.3 kgf · m
(1.4~2.1 lbf · ft)

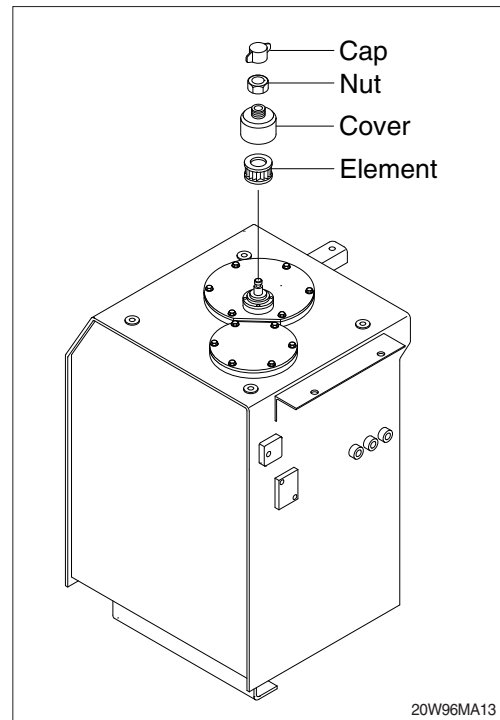

24) REPLACE OF DRAIN FILTER CARTRIDGE

Clean the dust around filter and replace with new one after removing the cartridge.

- ※ Tighten about 2/3 turn more after the gasket of cartridge contacts seal side of filter body for mounting.
- ※ Change cartridge after initial 250 hours of operation. Thereafter, change cartridge every 1000 hours.

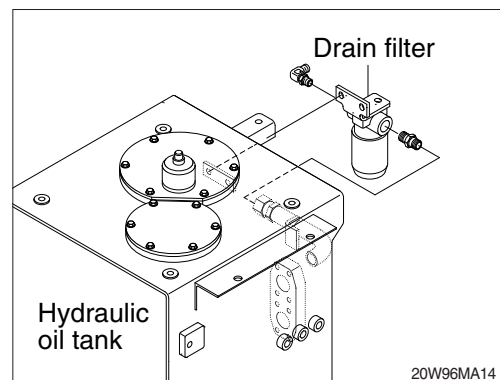

25) REPLACE OF PILOT LINE FILTER

- (1) Loosen the nut positioned on the filter body.
 - (2) Pull out the filter element and clean filter housing.
 - (3) Install the new element and tighten using specified torque.
- ※ Change cartridge after initial 250 hours of operation. Thereafter, change cartridge every 1000 hours.

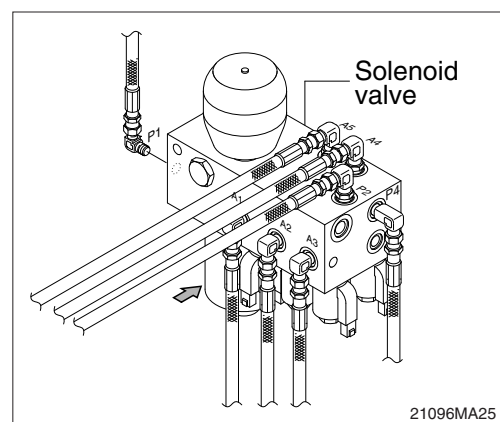

(4) Welding repair

Before start to welding, follow the below procedure.

- ① Shut off the engine and remove the starting switch.
- ② Disconnect ground cable from battery by master switch.
- ③ Before carrying out any electric welding on the machine, the battery cables should be disconnected and the connectors pulled out of the electronic control units (MCU, cluster etc).
- ④ Connect the earth (ground) lead of the welding equipment as close to the welding point as possible.

※ Do not weld or flame cut on pipes or tubes that contain flammable fluids. Clean them thoroughly with nonflammable solvent before welding or flame cutting on them.

▲ Do not attempt to welding work before carry out the above.

If not, it will caused serious damage at electric system.

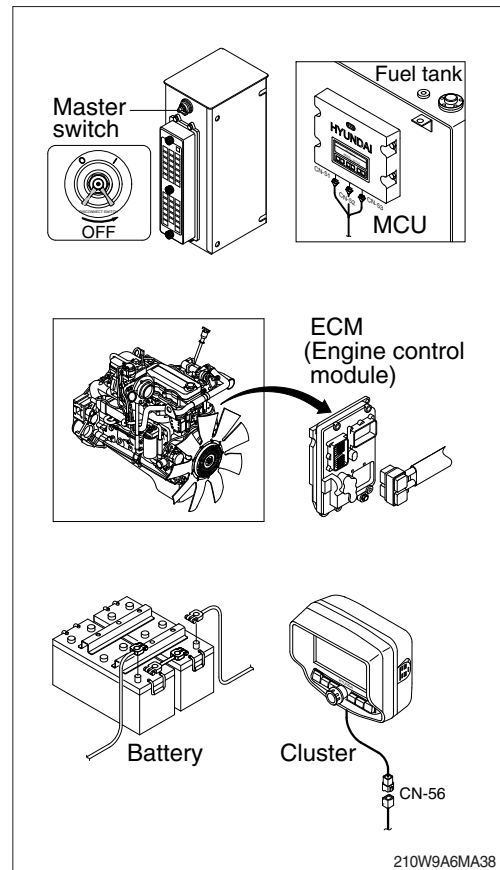

CLICK HERE TO **DOWNLOAD** THE COMPLETE MANUAL

- Thank you very much for reading the preview of the manual.
- You can download the complete manual from: www.heydownloads.com by clicking the link below



- Please note: If there is no response to CLICKING the link, please download this PDF first and then click on it.

CLICK HERE TO **DOWNLOAD** THE COMPLETE MANUAL