

CONTENTS

1. SAFETY HINTS

1. Before operating the machine	1-1
2. During operating the machine	1-6
3. During maintenance	1-13
4. Parking	1-16

2. SPECIFICATIONS

1. Major components	2-1
2. Specifications	2-2
3. Working range	2-6
4. Weight	2-11
5. Lifting capacities	2-14
6. Bucket selection guide	2-29
7. Undercarriage	2-31
8. Specification for major components	2-32
9. Recommended oils	2-36

3. CONTROL DEVICES

1. Cab devices	3-1
2. Cluster	3-2
3. Switches	3-8
4. Levers and pedals	3-13
5. Air conditioner and heater	3-16
6. Others	3-18

4. OPERATION

1. Suggestion for new machine	4-1
2. Check before starting the engine	4-2
3. Starting and stop the engine	4-3
4. Warming-up operation	4-9
5. Operation of the working device	4-10
6. Traveling of the machine	4-11

CLICK HERE TO **DOWNLOAD** THE COMPLETE MANUAL

- Thank you very much for reading the preview of the manual.
- You can download the complete manual from: www.heydownloads.com by clicking the link below



- Please note: If there is no response to CLICKING the link, please download this PDF first and then click on it.

CLICK HERE TO **DOWNLOAD** THE COMPLETE MANUAL

ROTATING BEACON

When you operate a machine on a road or beside a road, a rotating beacon is required to avoid any traffic accident.

Please contact your Hyundai distributor to install it.

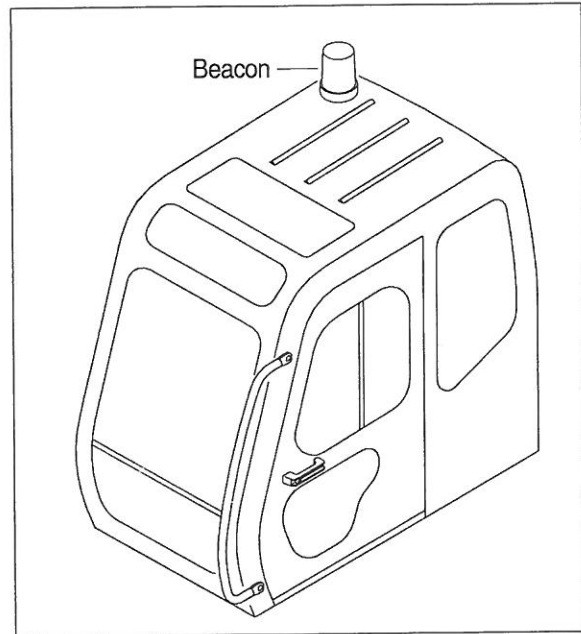

PRECAUTIONS FOR ATTACHMENTS

When installing and using an optional attachment, read the instruction manual for the attachment and the information related to attachments in this manual.

Do not use attachments that are not authorized by Hyundai or your Hyundai distributor. Use of unauthorized attachments could create a safety problem and adversely affect the proper operation and useful life of the machine.

Any injuries, accidents, product failures resulting from the use of unauthorized attachments will not be the responsibility of Hyundai.

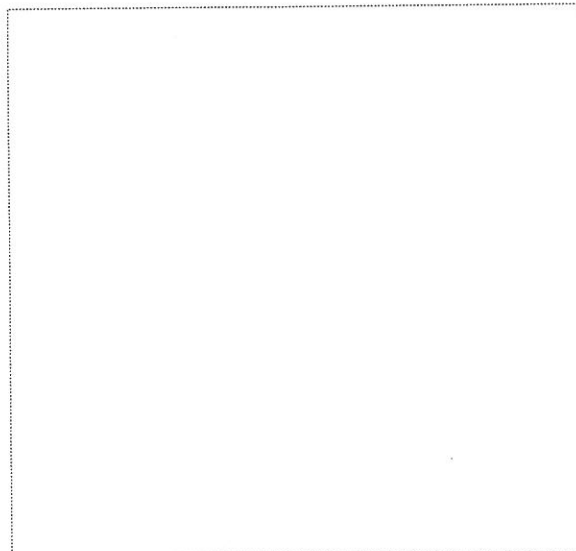

SAFETY RULES

Only trained and authorized personnel can operate and maintain the machine.

Follow all safety rules, precautions and instructions when operating or performing maintenance on the machine.

When working with another operator or a person on worksite traffic duty, be sure all personnel understand all hand signals that are to be used.

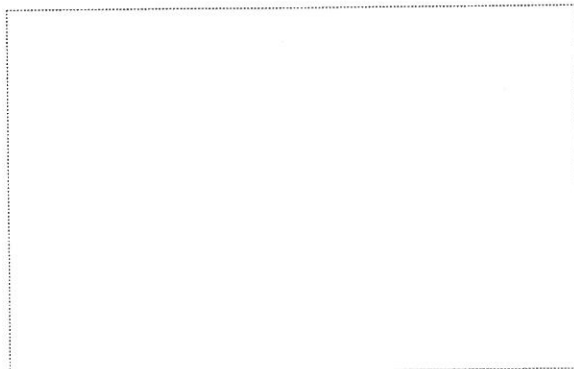

There is the danger of fire in fuel and oil.
Store in cool dry area, away from any open flames.

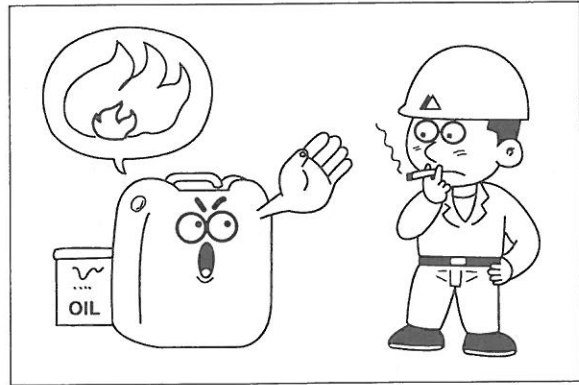

Do not touch exhaust pipe, or may cause severe burn.

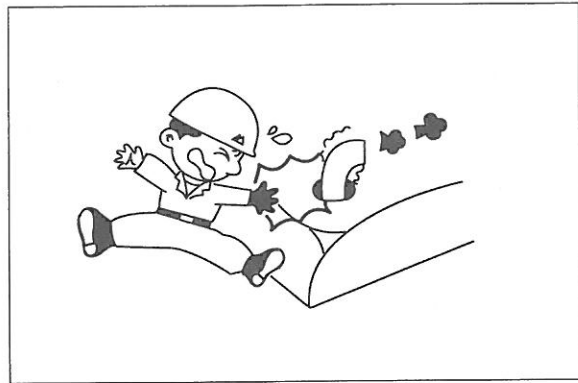

Do not open the engine hood and covers during the engine is running.

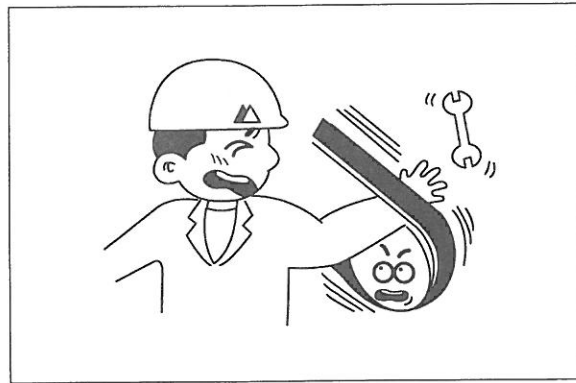

Be careful of not hitting the edges when you service engine.

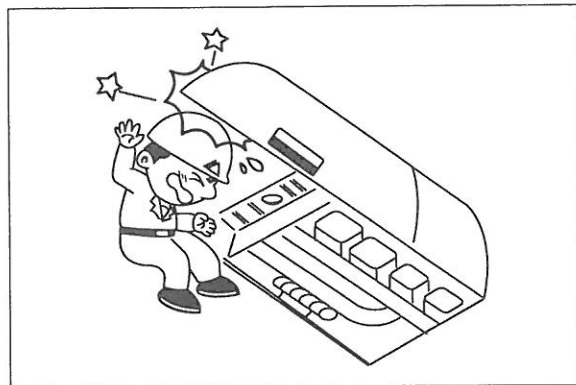



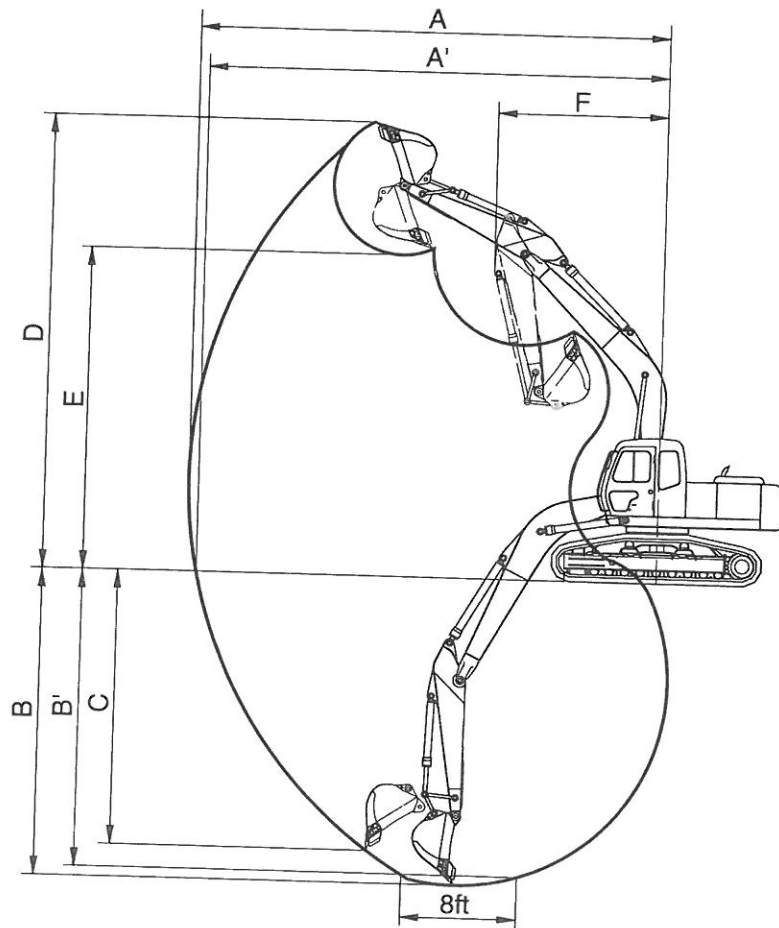







4) HIGH CHASSIS (5.68m(18' 8") BOOM)















Description		2.0m(6' 7") Arm	2.40m(7' 10") Arm	2.92m(9' 7") Arm	3.90m(12' 10") Arm
Max. digging reach	A	9150mm (30' 0")	9470mm (31' 1")	9920mm (32' 7")	10850mm (35' 7")
Max. digging reach on ground	A'	8940mm (29' 4")	9270mm (30' 5")	9720mm (31' 11")	10670mm (35' 0")
Max. digging depth	B	5640mm (18' 6")	6040mm (19' 10")	6560mm (21' 6")	7540mm (24' 9")
Max. digging depth (8ft level)	B'	5420mm (17' 9")	5830mm (19' 2")	6350mm (20' 10")	7390mm (24' 3")
Max. vertical wall digging depth	C	5060mm (16' 7")	5350mm (17' 7")	5860mm (19' 3")	6840mm (22' 5")
Max. digging height	D	9340mm (30' 8")	9430mm (30' 11")	9580mm (31' 5")	10090mm (33' 1")
Max. dumping height	E	6540mm (21' 5")	6640mm (21' 9")	6800mm (22' 4")	7300mm (23' 11")
Min. swing radius	F	3840mm (12' 7")	3780mm (12' 5")	3580mm (11' 9")	3600mm (11' 10")
Bucket digging force		114.7 [125.5] kN	114.7 [125.5] kN	114.7 [125.5] kN	114.7 [125.5] kN
		11700 [12800] kgf	11700 [12800] kgf	11700 [12800] kgf	11700 [12800] kgf
		25790 [28220] lbf	25790 [28220] lbf	25790 [28220] lbf	25790 [28220] lbf
Arm digging force		128.0 [140.0] kN	114.1 [124.7] kN	93.2 [102.0] kN	76.2 [83.2] kN
		13050 [14270] kgf	11630 [12720] kgf	9500 [10400] kgf	7770 [8490] kgf
		28770 [31460] lbf	25640 [28040] lbf	20940 [22930] lbf	17130 [18720] lbf

[] : Power boost

(2) 5.68m(18' 8") boom, 2.0m(6' 7") arm equipped with 0.87m³(PCSA heaped) bucket and 600mm (24") triple grouser shoe.

Load point height		Load radius								At max. reach				
		3.0m(10ft)		4.5m(15ft)		6.0m(20ft)		7.5m(25ft)		Capacity		Reach m(ft)		
														
7.5m (25ft)	kg lb											*3730 *8220	*3730 *8220	6.60 (21.7)
6.0m (20ft)	kg lb					*4180 *9220	*4180 *9220					*3780 *8330	3050 6720	7.75 (25.4)
4.5m (15ft)	kg lb			*5430 *11970	*5430 *11970	*4570 *10080	4450 10030					*3890 *8580	2570 5670	8.42 (27.6)
3.0m (10ft)	kg lb			*7040 *15520	6730 14840	*5270 *11620	4330 9550	*4520 *9960	3000 6610			3970 8750	2350 5180	8.74 (28.7)
1.5m (5ft)	kg lb			*8410 *18540	6280 13850	*5970 *13160	4110 9060	*4830 *10650	2910 6420			3910 8620	2300 5070	8.75 (28.7)
Ground Line	kg lb			*8990 *19820	6100 13450	*6420 *14150	3980 8770	4880 10760	2850 6280			4110 9060	2410 5310	8.46 (27.8)
-1.5m (-5ft)	kg lb	*12160 *26810	*12160 *26810	*8880 *19580	6080 13400	*6460 *14240	3940 8690					*4500 *9920	2750 6060	7.81 (25.6)
-3.0m (-10ft)	kg lb	*11360 *25040	*11360 *25040	*8070 *17790	6190 13650	*5790 *12760	4030 8880					*4470 *9850	3570 7870	6.69 (21.9)

(3) 5.68m(18' 8") boom, 2.40m(7' 10") arm equipped with 0.87m³(PCSA heaped) bucket and 600mm (24") triple grouser shoe.

Load point height		Load radius								At max. reach				
		1.5m(5ft)		3.0m(10ft)		4.5m(15ft)		6.0m(20ft)		7.5m(25ft)		Capacity		Reach m(ft)
														
7.5m (25ft)	kg lb											*3410 *7520	*3410 *7520	7.05 (23.1)
6.0m (20ft)	kg lb					*3770 *8310	*3770 *8310					*3490 *7690	2820 6220	8.13 (26.7)
4.5m (15ft)	kg lb					*4220 *9300	*4220 *9300	*3960 *8730	3100 6830			*3610 *7960	2390 5270	8.77 (28.8)
3.0m (10ft)	kg lb					*6500 *14330	*6500 *14330	*4950 *10910	4350 9590	*4260 *9390	3010 6640	3730 8220	2190 4830	9.07 (29.8)
1.5m (5ft)	kg lb					*8000 *17640	6320 13930	*5720 *12610	4110 9060	*4640 *10230	2890 6370	3670 8090	2130 4700	9.08 (29.8)
Ground Line	kg lb					*8810 *19420	6070 13380	*6260 *13800	3950 8710	4850 10690	2810 6190	3830 8440	2220 4890	8.80 (28.9)
-1.5m (-5ft)	kg lb			*11770 *25950	*11770 *25950	*8910 *19640	6000 13230	*6440 *14200	3880 8550			4290 9460	2500 5510	8.18 (26.8)
-3.0m (-10ft)	kg lb	*12820 *28260	*12820 *28260	*12070 *26610	*12070 *26610	*8330 *18360	6080 13400	*6040 *13320	3930 8660			*4410 *9720	3170 6990	7.14 (23.4)
-4.5m (-15ft)	kg lb			*9580 *21120	*9580 *21120	*6670 *14700	6320 13930							

6. BUCKET SELECTION GUIDE

1) GENERAL BUCKET

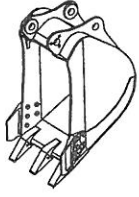
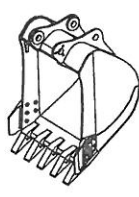
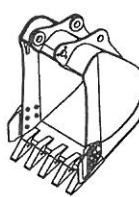
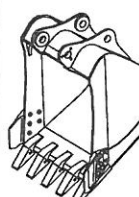
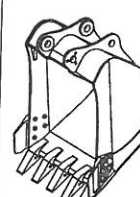
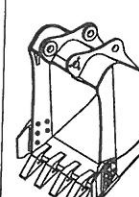
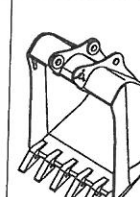
						
0.51m³ PCSA heaped bucket	0.80m³ PCSA heaped bucket	0.87m³ PCSA heaped bucket	0.92m³ PCSA heaped bucket	1.05m³ PCSA heaped bucket	1.20m³ PCSA heaped bucket	1.34m³ PCSA heaped bucket

Capacity		Width		Weight	Recommendation					
PCSA heaped	CECE heaped	Without side cutter	With side cutter		5.68m (18' 8") boom				5.2m (17' 7") boom	
					2.0m arm (6' 7")	2.4m arm (7' 10")	2.92m arm (9' 7")	3.9m arm (12' 9")	2.0m arm (6' 7")	2.4m arm (7' 10")
0.51m³ (0.67yd³)	0.45m³ (0.59yd³)	700mm (27.6")	820mm (32.3")	580kg (1280lb)						
0.80m³ (1.05yd³)	0.70m³ (0.92yd³)	1000mm (39.4")	1120mm (44.1")	650kg (1430lb)						
0.87m³ (1.14yd³)	0.75m³ (0.98yd³)	1090mm (42.9")	1210mm (47.6")	660kg (1460lb)						
0.92m³ (1.20yd³)	0.80m³ (1.05yd³)	1130mm (44.5")	1250mm (49.2")	710kg (1570lb)						
1.05m³ (1.37yd³)	0.90m³ (1.18yd³)	1250mm (49.2")	1370mm (53.9")	740kg (1630lb)						
1.20m³ (1.57yd³)	1.00m³ (1.31yd³)	1400mm (55.1")	—	770kg (1700lb)						
1.34m³ (1.75yd³)	1.15m³ (1.50yd³)	1550mm (61.1")	—	800kg (1760lb)						

- Applicable for materials with density of 2000kg/m³ (3370lb/yd³) or less
- Applicable for materials with density of 1600kg/m³ (2700lb/yd³) or less
- Applicable for materials with density of 1100kg/m³ (1850lb/yd³) or less

(2) Fuel gauge

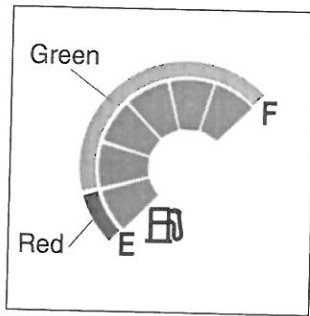

- ① This gauge indicates the amount of fuel in the fuel tank.
- ② Fill the fuel when the red range illuminates.
- ③ The gauge indicates continuously the current fuel amount even after turn OFF the starting switch. This does not mean that the gauge is out of order.

* If the gauge illuminates the red range even though the machine is on the normal condition, check the electric device as that can be caused by the poor connection of electricity or sensor.

(3) Engine coolant temperature gauge

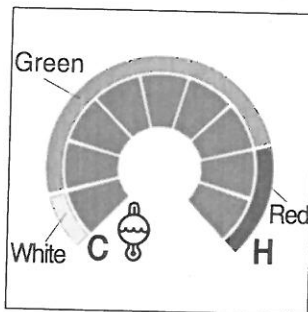

- ① This indicates the temperature of coolant.
 - White range : 40-60 °C(104-140 °F)
 - Green range : 60-102 °C(140-216 °F)
 - Red range : 102 °C(216 °F) above
- ② The green range illuminates when operating.
- ③ Keep idling engine at low speed until the green range illuminates, before operation of machine.
- ④ When the red range illuminates, turn OFF the engine, check the radiator and engine.

(4) Coolant level warning lamp

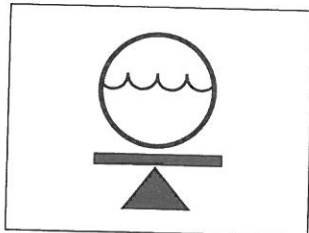

- ① This lamp is turned ON when the coolant is below LOW in the reservoir tank of radiator.
- ② Check the reservoir tank when the lamp is ON.

(5) Overheat warning lamp

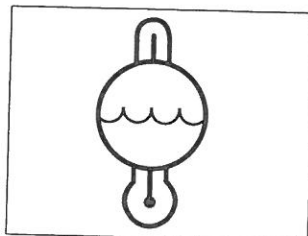

- ① This lamp is turned ON when the temperature of coolant is over the normal temperature(110 °C, 230 °F).
- ② Check the cooling system when the lamp is ON.

4. LEVERS AND PEDALS

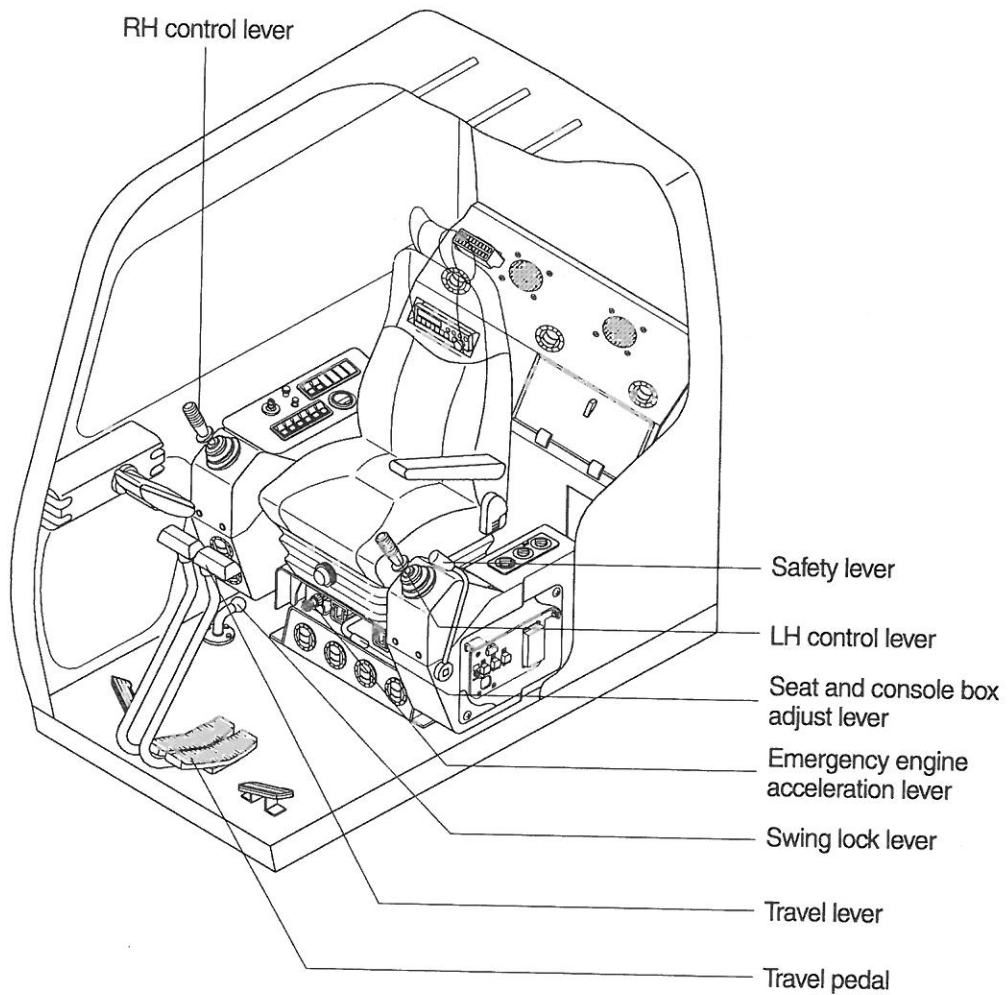

1) LH CONTROL LEVER

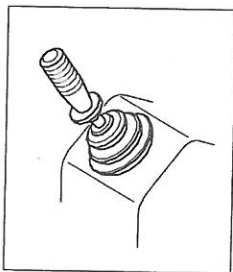

- (1) This joystick is used to control the swing and the arm.
- (2) Refer to **operation of working device** in chapter 4 for details.

2) RH CONTROL LEVER

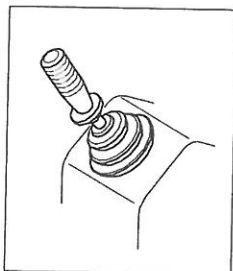

- (1) This joystick is used to control the boom and the bucket.
- (2) Refer to **operation of working device** in chapter 4 for details.

CLICK HERE TO **DOWNLOAD** THE COMPLETE MANUAL

- Thank you very much for reading the preview of the manual.
- You can download the complete manual from: www.heydownloads.com by clicking the link below



- Please note: If there is no response to CLICKING the link, please download this PDF first and then click on it.

CLICK HERE TO **DOWNLOAD** THE COMPLETE MANUAL

1. SUGGESTION FOR NEW MACHINE

- 1) It takes about 100 operation hours to enhance its designed performance.
- 2) Operate according to below three steps and avoid excessive operation for the initial 100 hours.

Service meter	Load
Until 10 hours	About 60%
Until 100 hours	About 80%
After 100 hours	100%

※ Excessive operation may deteriorate the potential performance of machine and shorten lifetime of the machine.

3) Be careful during the initial 100 hours operation

- (1) Check daily for the level and leakage of coolant, engine oil, hydraulic oil and fuel.
- (2) Check regularly the lubrication and fill. Grease daily all lubrication points.
- (3) Tighten bolts.
- (4) Warm up the machine fully before operation.
- (5) Check the gauges occasionally during the operation.
- (6) Check if the machine is operating normally during operation.

4) Replace followings after initial 50 hours of operation

Checking items	Service
Engine oil	Replace
Engine oil filter element	
Hydraulic oil return filter element	
Hydraulic oil tank drain filter cartridge	
Line filter element	
Fuel filter	

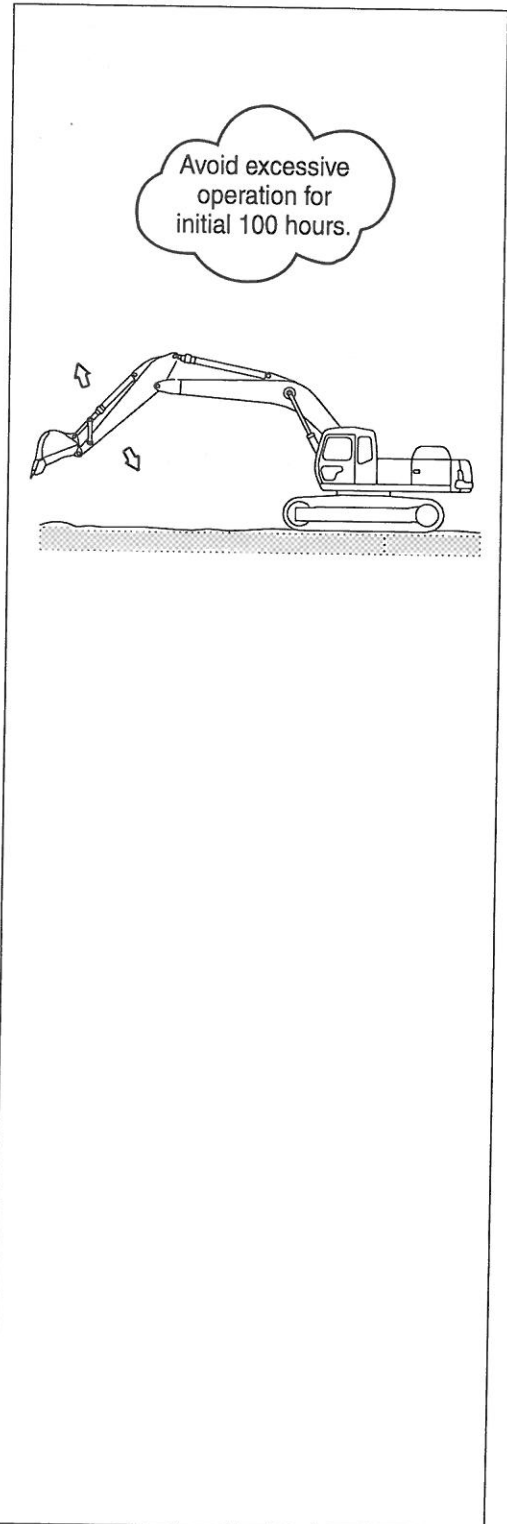

6. TRAVELING OF THE MACHINE

1) BASIC OPERATION

(1) Traveling position

It is the position which the traveling motor is in the rear and the working device is forward.

⚠ Be careful as the traveling direction will be reversed when the whole machine is swung 180 degree.

(2) Traveling operation

It is possible to travel by either travel lever or pedal.

- ※ Do not travel continuously for a long time.
- ※ Reduce the engine speed and travel at a low speed when traveling on uneven ground.

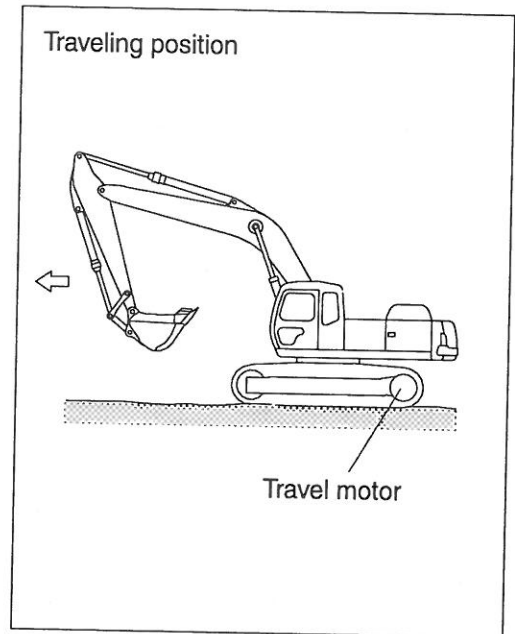

(3) Forward and backward traveling

When the left and right travel lever or pedal are pushed at the same time, the machine will travel forward or backward.

- ※ The speed can be controlled by the operation stroke of lever or pedal and change of direction will be controlled by difference of the left and right stroke.

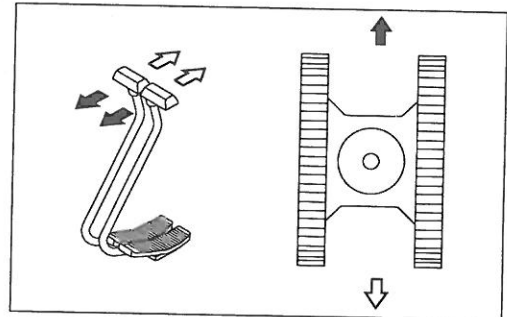

(4) Pivot turning

Operating only one side of lever or pedal make the change of direction possible by moving only one track.

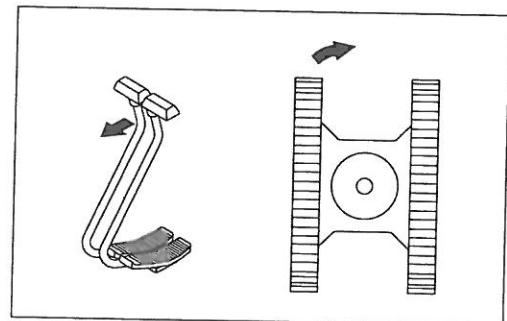

(5) Counter rotation

It is to change the direction at the original place by moving the right and left track. Both side of lever or pedal are operated to the other way at the same time.

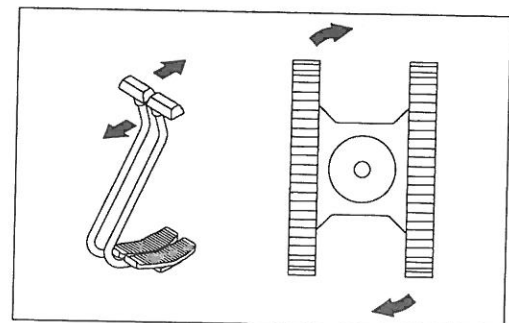

10. ATTACHMENT LOWERING (When engine is stopped)

- 1) On machines equipped with an accumulator, for a short time (within 2 minutes) after the engine is stopped, the attachment will lower under its own weight when the attachment control lever is shifted to LOWER. That happens only starting switch ON position and safety lever UNLOCK position. After the engine is stopped, set the safety lever to the LOCK position.
- 2) The accumulator is filled with high-pressure nitrogen gas, and it is extremely dangerous if it is handled in the wrong way. Always observe the following precautions.
 - (1) Never make any hole in the accumulator expose it to flame or fire.
 - (2) Do not weld anything to the accumulator.
 - (3) When carrying out disassembly or maintenance of the accumulator, or when disposing of the accumulator, it is necessary to release the gas from the accumulator. A special air bleed valve is necessary for this operation, so please contact your Hyundai distributor.

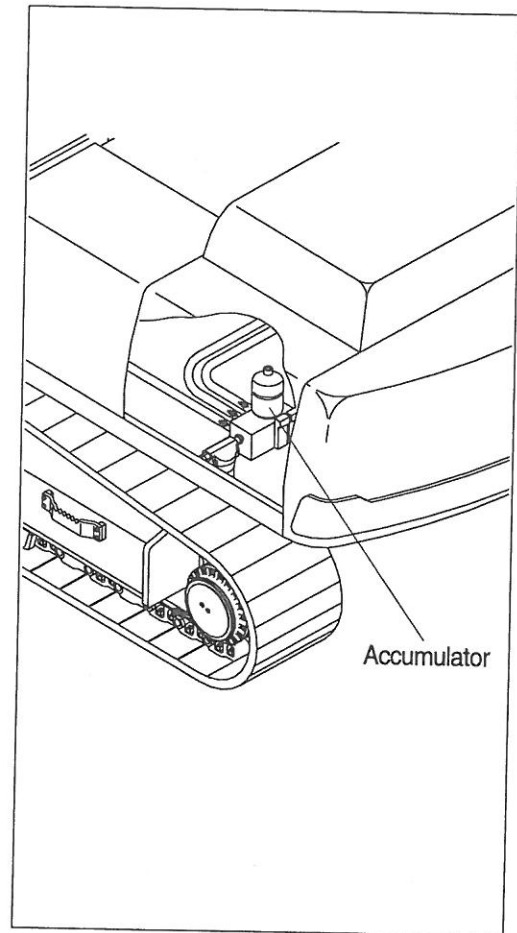

4) ROBEX 210LC-3 HIGH CHASSIS

(1) Base machine

Mark	Description	Unit	Specification
L	Length	mm(ft-in)	4970(16' 4")
H	Height	mm(ft-in)	3130(10' 3")
W	Width	mm(ft-in)	3505(11' 6")
Wt	Weight	kg(lb)	19430(42840)

※ With 710mm(28") double grouser shoes and 3800kg(8380lb) counterweight.

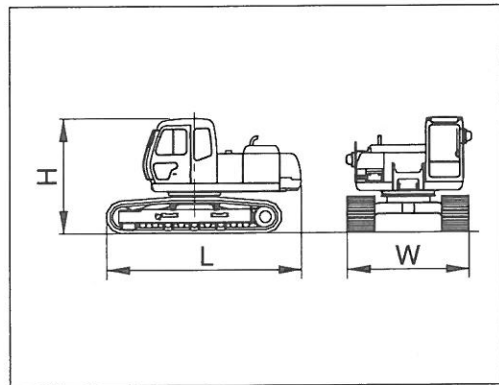

(2) Boom assembly

Mark	Description	Unit	Specification
L	Length	mm(ft-in)	5865(19' 3")
H	Height	mm(ft-in)	1550(5' 1")
W	Width	mm(ft-in)	710(2' 4")
Wt	Weight	kg(lb)	1685(3710)

※ 5.68m(18' 8") boom with arm cylinder(included piping and pins).

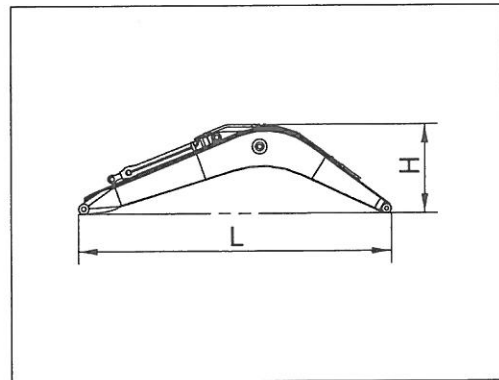

(3) Arm assembly

Mark	Description	Unit	Specification
L	Length	mm(ft-in)	3880(12' 9")
H	Height	mm(ft-in)	820(2' 8")
W	Width	mm(ft-in)	470(1' 7")
Wt	Weight	kg(lb)	880(1940)

※ 2.92m(9' 7") arm with bucket cylinder(included linkage and pins).

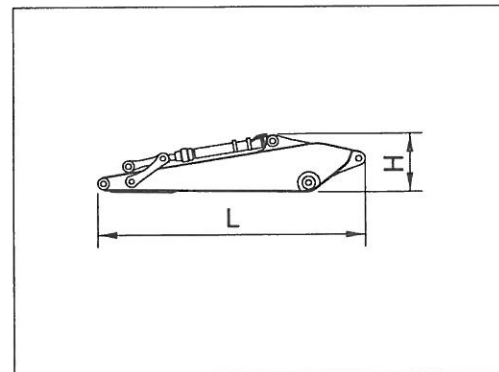

(4) Bucket assembly

Mark	Description	Unit	Specification
L	Length	mm(ft-in)	1980(6' 0")
H	Height	mm(ft-in)	240(0' 9")
W	Width	mm(ft-in)	1210(3' 12")
Wt	Weight	kg(lb)	655(1440)

※ 0.87m³(1.14yd³) PCSA heaped bucket(included tooth and side cutters).

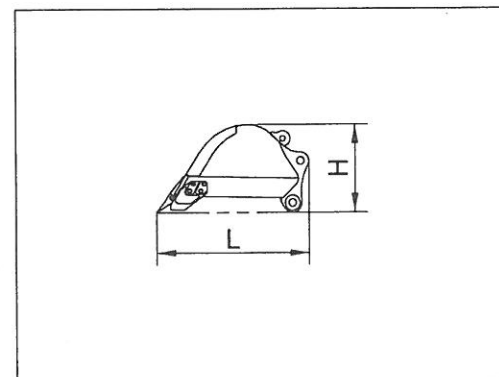

5) PRECAUTION WHEN INSTALLING HYDRAULIC HOSES OR PIPES

- (1) Be particularly careful that the joint of hose, pipe and functioning item are not damaged.
Avoid contamination.
- (2) Assemble after cleaning the hose, pipe and joint of functioning item.
- (3) Use genuine parts.
- (4) Do not assemble the hose in the condition of twisted or sharp radius.
- (5) Keep the specified tighten torque.

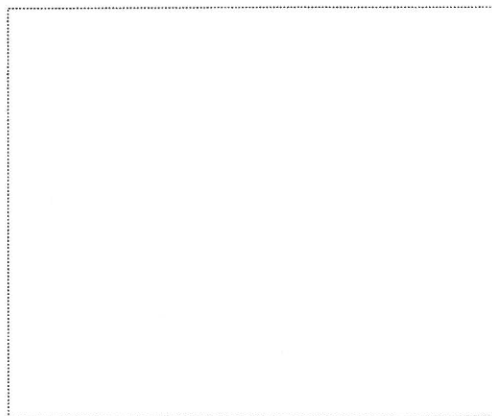

8) EVERY 2000 HOURS SERVICE

Check items	Service	Page
Hydraulic tank		
★ · Oil	Change	6-30
· Suction strainer	Check, Clean	6-30
Coolant	Change	6-19, 20, 21, 22, 23

★Change oil every 600 hours of continuous hydraulic breaker operation.

9) WHEN REQUIRED

Whenever you have trouble in the machine, you must perform the service of related items, system by system.

Check items	Service	Page
Fuel system		
· Fuel tank	Drain or Clean	6-25
· Water separator	Drain or Replace	6-26
· Fuel filter	Replace	6-26
Engine lubrication system		
· Engine oil	Change	6-17, 18
· Engine oil filter	Replace	6-17, 18
Engine cooling system		
· Coolant	Add or Change	6-19, 20, 21, 22, 23
· Radiator	Clean or Flush	6-19, 20, 21, 22, 23
Engine air system		
· Air cleaner	Replace	6-25
Hydraulic system		
· Hydraulic oil	Add or Change	6-29, 30
· Return filter	Replace	6-31
· Drain line filter	Replace	6-32
· Pilot line filter	Replace	6-32
· Element of breather	Replace	6-31
· Suction strainer	Clean	6-30
Under carriage		
· Track tension	Check, Adjust	6-35
Bucket		
· Tooth	Replace	6-37
· Side cutter	Replace	6-37
· Linkage	Adjust	6-38
· Bucket assy	Replace	6-36
Air conditioner and heater		
· Outer filter	Check, Clean, Replace	6-43
· Inner filter	Check, Clean, Replace	6-43, 44

- (3) Inspect the drive belt, tension bearing and fan hub.

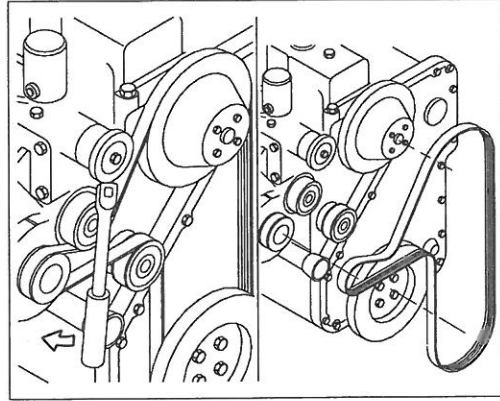

7) INSPECTION OF COOLING FAN

- ⚠ Personal injury can result from a fan blade failure. Never pull or pry on the fan. This can damage the fan blade and cause fan failure.
- ✳ Rotate the crankshaft by using the engine barring gear.
- ✳ A visual inspection of the cooling fan is required daily.
Check for cracks, loose rivets, and bent or loose blades.
Check the fan to make sure it is securely mounted. Tighten the capscrews if necessary.
Replace any fan that is damaged.

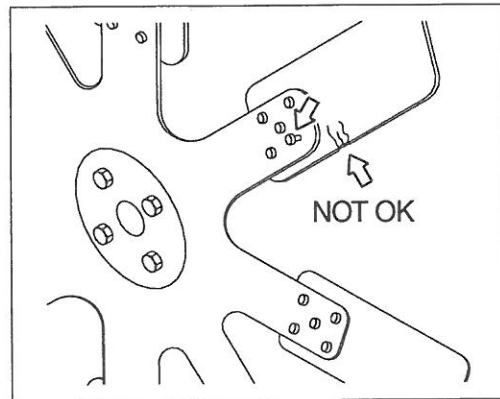

26) CHECK THE TRAVEL REDUCTION GEAR OIL

- (1) Operate the machine to the position of drain plug down to the flat ground.
- (2) Loosen the level plug and check the oil level. If the level is at the hole of the plug, it is normal. Fill the oil if it is not sufficient.

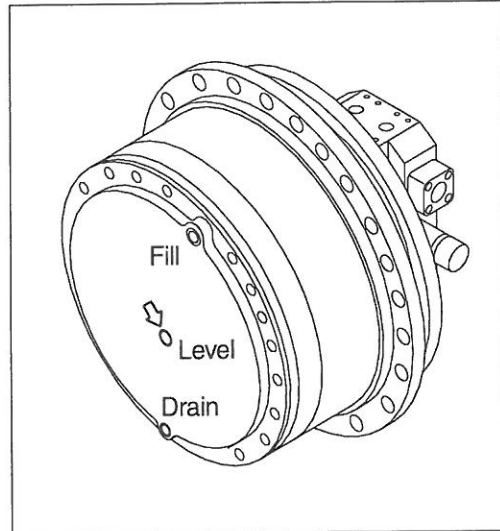

27) CHANGE OF THE TRAVEL REDUCTION GEAR OIL

- (1) Raise the temperature of the oil by traveling machine first.
- (2) Stop when the position of the drain plug is down.
- (3) Loosen the level plug and then the drain plug.
- (4) Drain the oil to adequate container.
- (5) Tighten the drain plug and fill specified amount of oil at filling port.
- (6) Tighten the level plug and travel slowly to check if there is any leakage of oil.

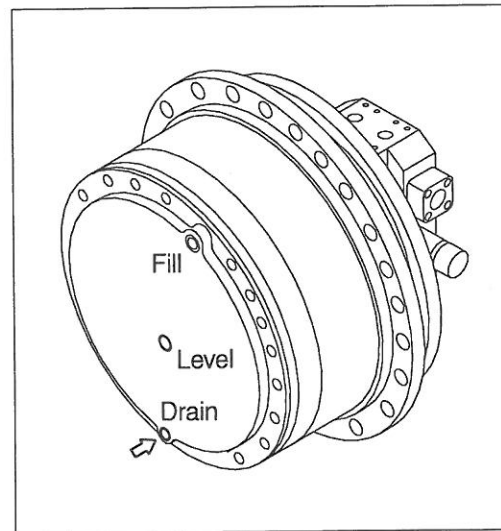

28) LUBRICATE RCV LEVER

Remove the bellows and with a grease gun grease the joint part(A) and sliding parts(B).

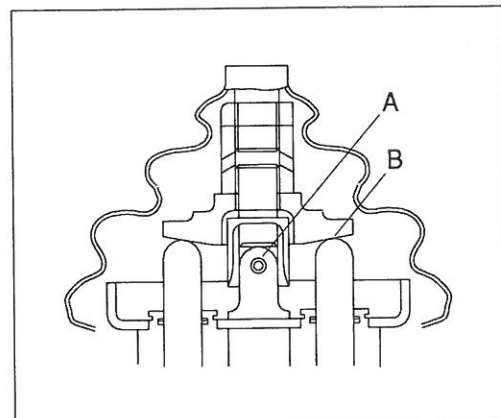

CLICK HERE TO **DOWNLOAD** THE COMPLETE MANUAL

- Thank you very much for reading the preview of the manual.
- You can download the complete manual from: www.heydownloads.com by clicking the link below



- Please note: If there is no response to CLICKING the link, please download this PDF first and then click on it.

CLICK HERE TO **DOWNLOAD** THE COMPLETE MANUAL