

CONTENTS

Foreword	0-1
Emission-related components warranty (USA and CANADA only)	0-2
Before servicing this machine	0-3
EC regulation approved	0-4
Table to enter S/No and distribution	0-6
Machine data plate	0-7
Guide (direction, S/No, symbol)	0-8

SAFETY HINTS

1. Safety instructions	1-2
2. Safety labels	1-33

OPERATION

1. Instruction for new machine	2-1
2. Check before starting the engine	2-2
3. Starting and stopping the engine	2-3
4. Mode selection system	2-7
5. Operation of the working device	2-12
6. Traveling of the machine	2-13
7. Efficient working method	2-16
8. Operation in the special work sites	2-20
9. Normal operation of excavator	2-22
10. Attachment lowering	2-23
11. Storage	2-24
12. RCV lever operating pattern	2-26
13. Exhaust system cleaning	2-28

CONTROL DEVICES

1. Cab devices	3-1
2. Cluster	3-2
3. Switches	3-40
4. Levers and pedals	3-45
5. Others	3-48

MAINTENANCE

1. Instruction	4-1
2. Tightening torque	4-6
3. Fuel, coolant and lubricants	4-9

4. Maintenance check list	4-10
5. Maintenance chart	4-16
6. Service instruction	4-19
7. Electrical system	4-50
8. Air conditioner and heater	4-53

TRANSPORTATION

1. Preparation for transportation	5-1
2. Dimension and weight	5-2
3. Loading the machine	5-6
4. Fixing the machine	5-8
5. Loading and unloading by crane	5-9

TROUBLESHOOTING GUIDE

1. Engine	6-1
2. Electrical system	6-2
3. Others	6-3

SPECIFICATIONS

1. Major components	7-1
2. Specifications	7-2
3. Working range	7-6
4. Weight	7-8
5. Lifting capacities	7-9
6. Bucket selection guide	7-24
7. Undercarriage	7-28
8. Specification for major components	7-30
9. Recommended oils	7-33

HYDRAULIC BREAKER AND QUICK COUPLER

1. Selecting hydraulic breaker	8-1
2. Circuit configuration	8-2
3. Maintenance	8-3
4. Precaution while operating the breaker	8-4
5. Quick coupler	8-6

INDEX	9-1
-------------	-----

CLICK HERE TO **DOWNLOAD** THE COMPLETE MANUAL

- Thank you very much for reading the preview of the manual.
- You can download the complete manual from: www.heydownloads.com by clicking the link below



- Please note: If there is no response to CLICKING the link, please download this PDF first and then click on it.

CLICK HERE TO **DOWNLOAD** THE COMPLETE MANUAL

2. SAFETY INSTRUCTIONS

Safety Message

Intended Use

Machines should be operated in accordance with the procedures described in the operator manual.

The products described in the operator manual are designed and manufactured mainly for the following purposes:







- Excavation work
- Loading work
- Leveling work
- Drainage work
- Lifting work
- Demolition work

Do not operate the machine for any purpose other than those stated above or in areas where potential hazards have been identified. Make sure that you comply strictly with all safety instructions at all times. Please contact HD Hyundai Construction Equipment Co., Ltd. or your local dealer for more information.

HD Hyundai Construction Equipment strictly prohibits the use or operation of the machine in any of the following circumstances:

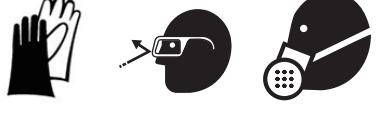
- Operation by an unskilled worker
- Lifting a worker up
- Transporting flammable or dangerous materials
- Driving down or extracting piles with the bucket
- Towing damaged vehicles

Personal protection gear for various situations

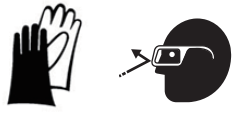
Situation	Symbol
Oil handling	
Battery handling	
Refrigerant handling	
Coolant handling	
Repair by welding	
Working in areas subject to airborne particles and falling objects	
Working in places with a high level of noise	
Handling machines damaged by fire or exposed to excessively high temperature	

WEAR PROTECTIVE CLOTHING

Wear close fitting clothing and safety equipment appropriate to the job.

- Do not wear loose clothing and accessories. Secure long hair. These items can snag on controls or on other parts of equipment.
- Do not wear oily clothes. They are highly flammable.
- Wear a hard hat, safety shoes, safety goggles, mask, leather gloves, earplugs and other protective equipment, as required.
- While working on machine, never use inadequate tools. They could break or slip, or they may not adequately perform intended.

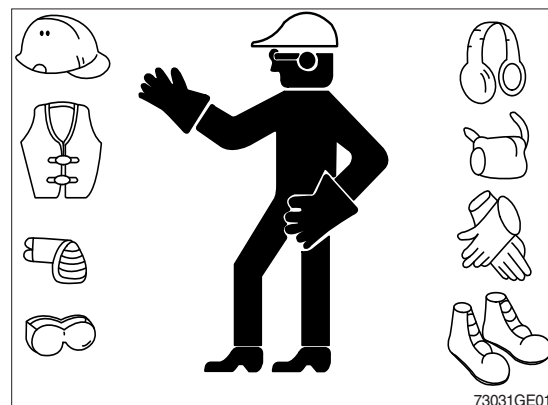

73031GE01

Cautions when operating in specific areas

Operating in extremely cold environments

- Do not attempt to start, stop or turn the machine suddenly as this may cause it to slip. There is potential for the machine to slip.
- Snow-covered or frozen ground may be slippery and dangerous.
- Idle operation of the machine may be required to elevate the engine temperature during startup.
- An impact resulting from a sudden movement of the boom or the attachments at an extremely low temperature may cause serious damage to the machine.
- The working cycle or loading weight might be reduced to lower than those under normal conditions.
- Follow these instructions when operation in cold environments:
 - Warm up the engine for 3~4 seconds when starting up the engine.
 - Always fully charge the battery. A discharged battery will freeze earlier than a fully charged battery.
 - Use engine oil and fuel that are appropriate for the temperature.
 - Keep the fuel tank full.
 - Remove any moisture from the fuel tank, and change the fuel filter regularly.
 - If the fuel filter is frozen, the flow of fuel may be blocked.
 - Pour the proper volume of antifreeze into the coolant.
 - Wait until the various parts of the machine reach the operating temperature after starting the engine.
 - Make sure that every controller and function of the machine operates normally.
 - Remove any dirt, snow and ice from the machine after completing the operation.

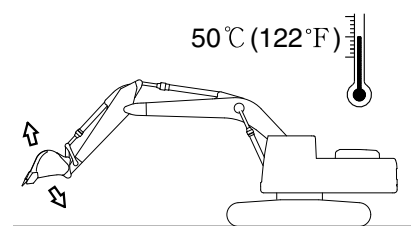

Operating in extremely hot environments

- Continuous operation of the machine for a long period of time may cause the machine to overheat. Pay special attention to prevent overheating of parts such as the engine and the hydraulic system. Stop the machine and take a break if necessary.
- Check the following conditions frequently:
- Check the level of the coolant in the radiator.
 - Check the radiator grill for clogging by any debris, and remove them, if any.
 - Check the level of the battery electrolyte.
 - If the battery will not be used for a long period of time, store it in a cool place.
 - Check the hydraulic system for oil leakage.
 - Check the lubrication oil on the respective parts, and lubricate as needed.
 - If the paint coating of any parts has been effaced or damaged, coat the parts with paints or treat them with an anti-rust additive.
 - Do not park the machine under direct light for a long period of time.
 - When parking or storing the machine outdoors, use the proper cover to protect the machine from sunlight and dust.

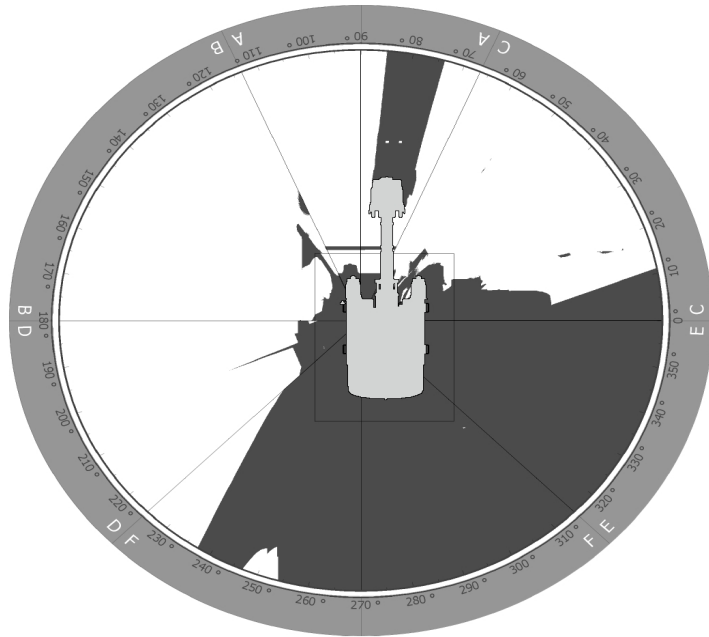

< Top view of the machine at ground level visibility without use of optional visual aids >

※ The shaded areas indicate the approximate location of areas with significant restricted visibility.
(Radius = 12 m / 34 ft)

There is restricted visibility to the area directly behind the machine with no optional visual aids. Failure to make sure the area is clear could result in serious injury or death. Make sure that the area is clear before you start the reverse movement.

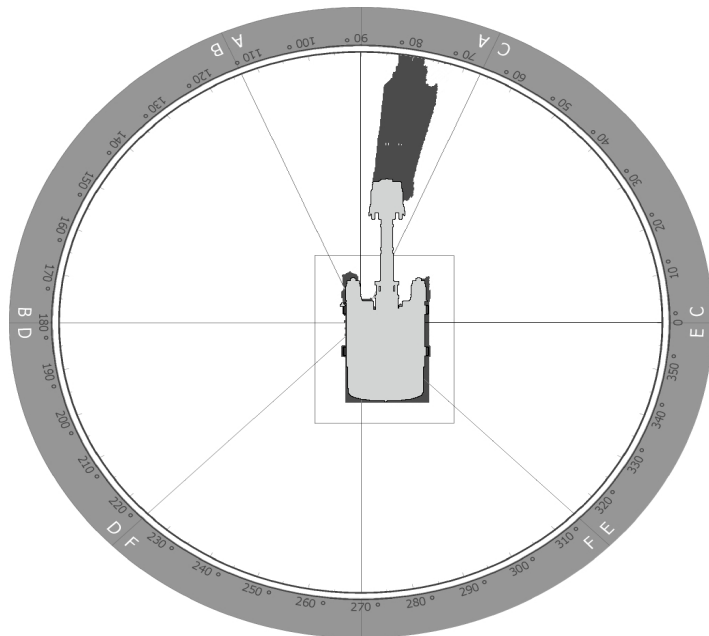

< Top view of the machine at ground level visibility with use of optional visual aids >

※ The shaded areas indicate the approximate location of areas with significant restricted visibility.
(Radius = 12 m / 34 ft)

26) CAUTION (W/SEPARATOR, TURBOCHARGER) (item 41)

This label is positioned on the right window of inside the cab.

- ⚠ In order to protect high pressure fuel system, please drain water in water separator before starting the engine.
- ⚠ In order to prevent turbocharger failure, please allow more than 5 minutes cool down period (no load low idle operation) before shutting the engine off.

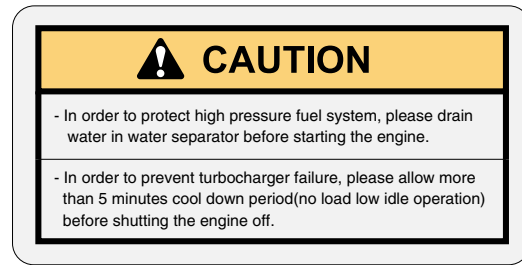

120090SL02

27) REFLECTING (item 42)

This label is positioned on the rear side of the counterweight.

- ⚠ To prevent serious personal injury or death keep clear of machine swing radius.
- ⚠ Do not deface or remove this label from the machine.



290F0FW01

28) ACCUMULATOR (item 43)

This label is positioned on the accumulator of the solenoid valve.

- ※ The accumulator is filled with high-pressure nitrogen gas, and it is extremely dangerous if it is handled in the wrong way. Always observe the following precautions.
- ⚠ Never make any holes in the accumulator or expose it to open flame or fire.
- ⚠ Do not weld anything to the accumulator.
- ※ When carrying out disassembly or maintenance of the accumulator, or when disposing of the accumulator. It is necessary to release the gas from the accumulator. A special air bleed valve is necessary for this operation, so please contact your HD Hyundai Construction Equipment distributor.

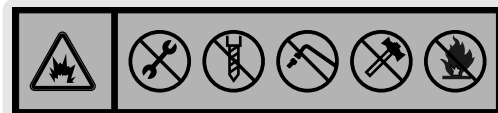

1107A0FW46

3. STARTING AND STOPPING THE ENGINE

1) CHECK INDICATOR LIGHTS

- (1) Confirm all operating levers are in the neutral position.
- (2) Turn the starting switch to the ON position.
Buzzer will sound for 4 seconds with HYUNDAI logo on cluster.
 - ※ If the ESL mode is set to enable mode, enter the password to start engine.
 - ※ If the incorrect password is entered a total of 5 times, you must wait 30 minutes before trying again.
 - ※ Refer to page 3-28 for ESL mode.
- (3) After initialization of cluster, the operating screen is displayed on LCD (1).
Also, self-diagnostic function is carried out.

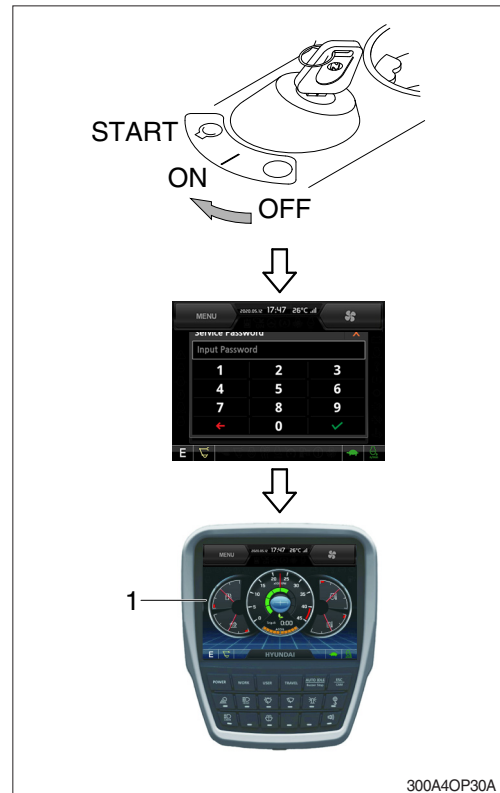

2) STARTING ENGINE IN NORMAL

- ▲ Check if any obstacles or people are in the working area. Sound the horn to warn anyone in the vicinity that you are starting the engine.

- (1) Turn the multimodal dial to low idle position.
- (2) Turn the starting switch to START position to start the engine.
 - △ Do not hold the starting switch in the START position for longer than 20 seconds. The start system may be seriously damaged.
 - ※ If the engine does not start, allow the stator to cool for about 2 minutes before re-attempting to start the engine again.
- (3) Release the starting switch instantly after the engine starts to avoid possible damage to the starting motor.



6. TRAVELING OF THE MACHINE

1) BASIC OPERATION

(1) Traveling position

The travel motor is in the rear and the working device is forward.

▲ **Be careful as the traveling direction will be the opposite when the machine is rotated 180°.**

(2) Traveling operation

It is possible to travel by either travel lever or pedal.

- ※ **Do not travel continuously for a long time.**
- ※ **Reduce the engine speed and travel at a low speed when traveling on uneven ground.**

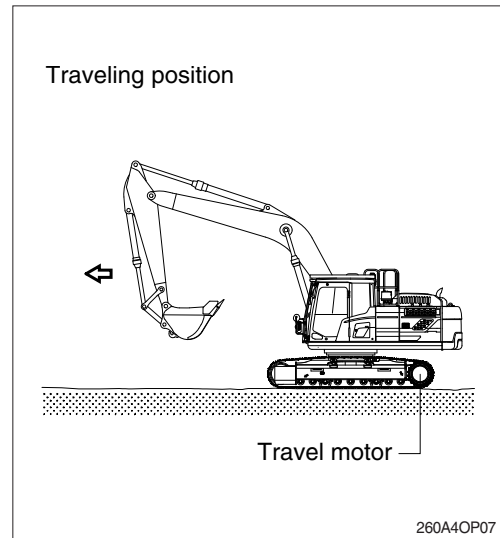

(3) Forward and backward traveling

When the left and right travel levers or pedals are pushed at the same time, the machine will travel forward or backward depending on your selection.

- ※ **The speed can be controlled by the operation stroke of lever or pedal and change of direction will be controlled by difference of the left and right stroke.**

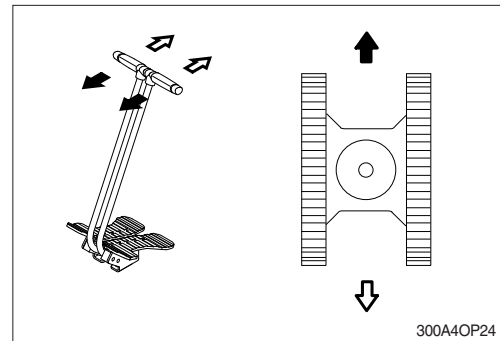

(4) Pivot turning

Operating only one side of lever or pedal makes the change of direction possible by moving only one track.

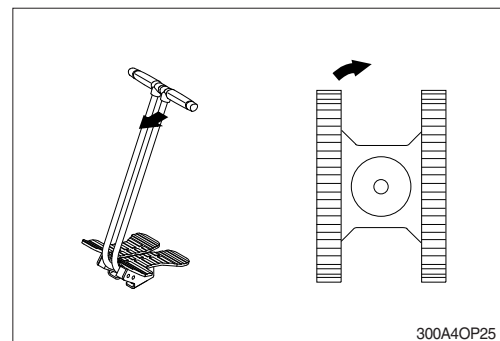

(5) Counter rotation

It is to rotate the undercarriage (only) while not advancing the machine forward or backward. This is accomplished by moving the travel levers and or pedals in the opposite direction of each other.

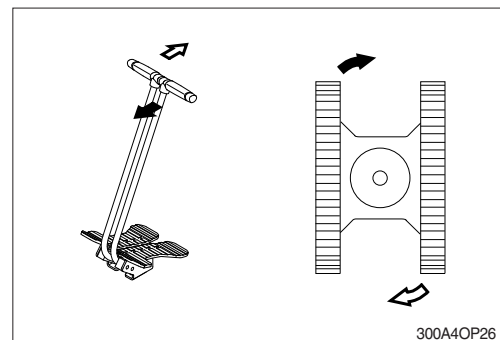

(4) Performance test

- ① Check how much the engine rpm drops during the boom up operation compared to the basic state.
- ② If the rpm drop amount is excessive, adjust the power shift value in the user mode by +1 step, and then recheck amount of rpm drop. Repeat the above steps until amount rpm drop is enough.

- Allowable amount : 300 ± 50 rpm

- ※ **The time it takes to recover the engine rpm should be less than 1 second.**

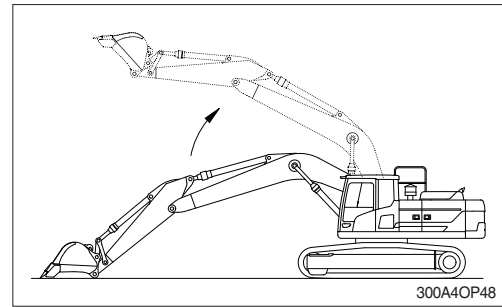

300A4OP48

2) GAUGE

(1) Operation screen

When you first turn starting switch ON, the operation screen will appear.



300A3CD21A

- | | | | |
|---|----------------------------------|---|-------------------------|
| 1 | RPM / Speed gauge | 5 | DEF/AdBlue® level gauge |
| 2 | Engine coolant temperature gauge | 6 | Tripmeter display |
| 3 | Hydraulic oil temperature gauge | 7 | Eco gauge |
| 4 | Fuel level gauge | 8 | Accel dial gauge |

(2) RPM / Speed gauge

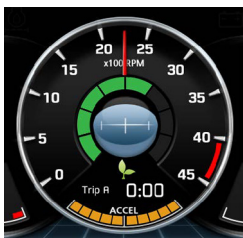



300A3CD22

- ① This displays the engine speed.

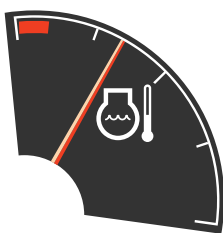
(3) Engine coolant temperature gauge



290F3CD53

- ① This gauge indicates the temperature of coolant.
- White range : 40-107°C (104-225°F)
 - Red range : Above 107°C (225°F)
- ② If the indicator is in the red range or  lamp pops up and the buzzer sounds, turn OFF the engine and check the engine cooling system.
- ※ If the gauge indicates the red range or  lamp blinks in red even though the machine is in the normal condition range, check the electric device as this can be caused by poor connection of sensor

(19) Engine oil filter warning lamp

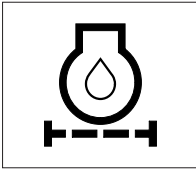

300A3CD306

- ① This warning lamp pops up and the buzzer sounds when the engine oil filter is clogged.
- ② Check, clean or replace filter.

(2) Mode setup

① Work tool

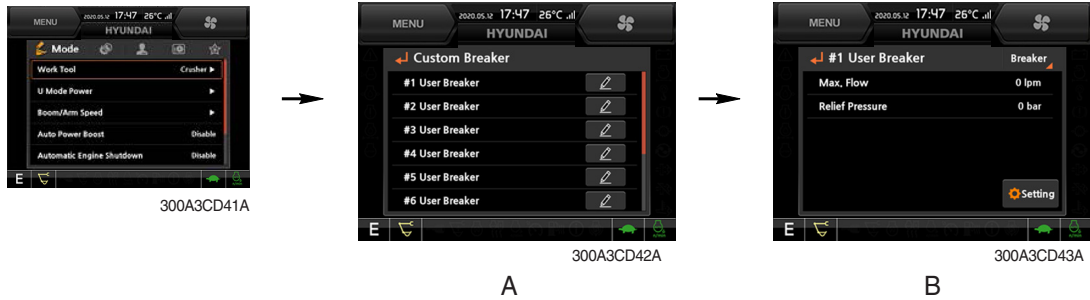

- Select installed optional attachment
 - A : It can set the user's attachment.
It is available in setting #1~#10.
 - B : Max flow - Set the maximum flow for the attachment.
Relief pressure - Set the relief pressure.

② U mode power

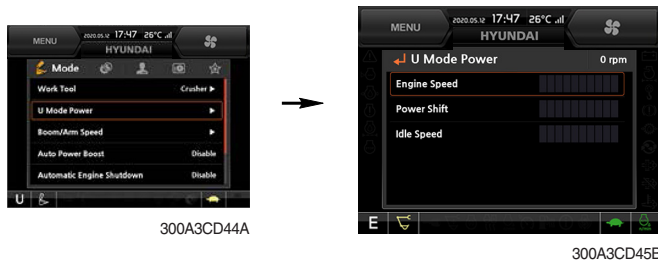

Step (■)	Engine speed (rpm)	Idle speed (rpm)	Power shift
1	1300	750	10%
2	1400	800	20%
3	1500	850	30%
4	1600	900	40%
5	1700	950	50%
6	1800	1000	60%
7	1850	1050	70%
8	1900	1100 (auto decel)	80%
9	1950	1150	85%
10	2000	1200	90%

- Engine high idle rpm, auto idle rpm and pump torque (power shift) can be modulated and memorized separately in U-mode.
- U-mode can be activated by user mode switch.

※ One touch decel & low idle : 1000 rpm

③ Combination speed setting

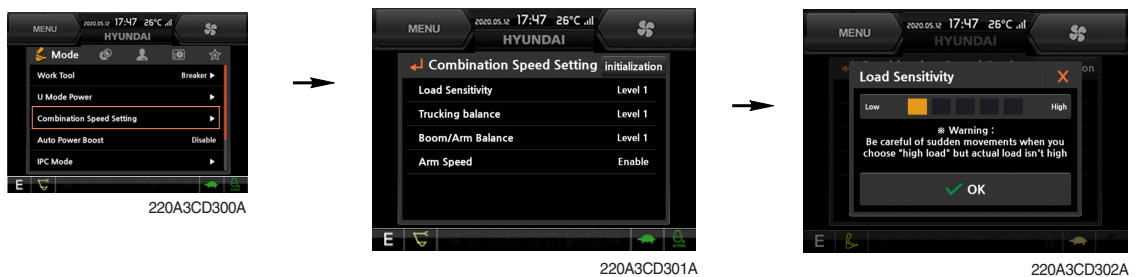

- **Load sensitivity**
 - It changes fine control sensitivity. (boom up or arm out operation)
 - When the segment is close to high, the fine operation speed is increased. (Load sensitivity is high.)
 - It is recommended to set high segment when lifting heavy duty equipment or load.
- ⚠ **The fine control speed is able to be unexpectedly fast by high setting and load condition. Do use the function through fine control test considering the condition.**

⑤ Machine Information

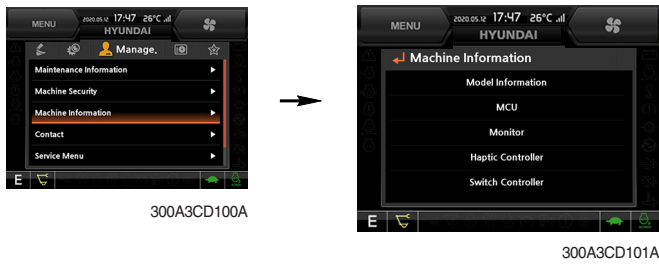

- This can confirm the identification of the model information (ECU), MCU, monitor, jog dial module, switch controller, RMCU, relay driver unit, FATC (air conditioner controller), AAVM (opt).

⑥ Contact (A/S phone number)



Enter the new A/S phone number

⑦ Service menu

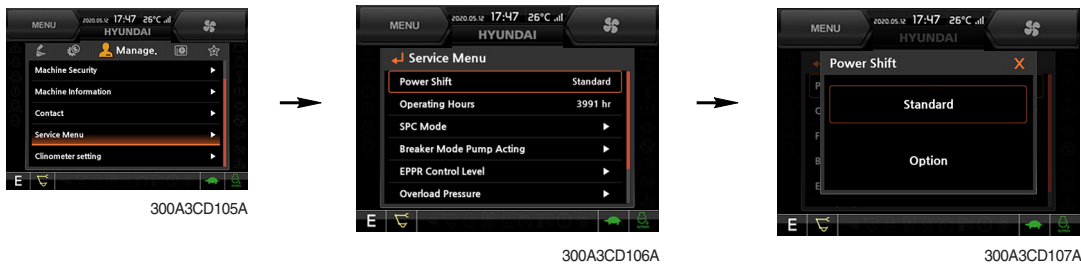

※ This menu can be used only HCE service man and can not be accessible by the owner and the operator.

- Power shift (standard / option) : Power shift pressure can be set by option menu.
- Operating hours : Operating hours since the machine line out can be checked by this menu.
- Breaker mode pump acting (1 pump / 2 pump)
- EPPR current level (attach flow EPPR 1 & 2, boom priority EPPR, attach relief pressure EPPR 1 & 2)
- Overload pressure : 100 ~ 350 bar
- Optional piping pressure removal (Disable / Enable)
It is removing the residual pressure remaining in the option line when the quick coupler is operated.
- Fine swing (Disable / Enable)

⑧ Clinometer

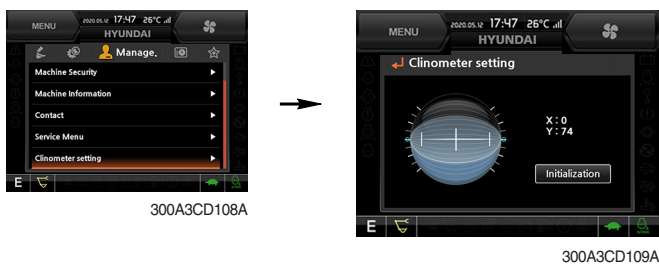

- When the machine is on the flatland, if you touch "initialization" on cluster, the values of X, Y will reset to "0".
- You can confirm tilt of machine in cluster's operating screen.

(10) Self Diagnosis Function

- ① Diagnostic methods : Diagnostic information window, select
- ② Diagnostic indication (Displays fault)

Fault code	Description	Fail safe function
F01	Ambient temperature sensor open	20°C alternate value control
F02	Ambient temperature sensor short	
F03	Cab inside temperature sensor open	25°C alternate value control
F04	Cab inside temperature sensor short	
F05	Evaporate temperature sensor open	0°C alternate value control
F06	Evaporate temperature sensor short	
F07	Null	-
F08	Null	-
F09	Mode 1 actuator open/short	The alternate value is face
F10	Mode 1 actuator drive circuit malfunction	If not, the alternate value is Def/Foot
F11	Intake actuator open/short	The alternate value is air recirculation
F12	Intake actuator drive circuit malfunction	The alternate fresh air
F13	Temperature actuator open/short	If opening amount is 0 %, the alternate value is 0 %
F14	Temperature actuator drive circuit malfunction	If not, the alternate value is 100 %
F15	Null	-
F16	Null	-

CLICK HERE TO **DOWNLOAD** THE COMPLETE MANUAL

- Thank you very much for reading the preview of the manual.
- You can download the complete manual from: www.heydownloads.com by clicking the link below



- Please note: If there is no response to CLICKING the link, please download this PDF first and then click on it.

CLICK HERE TO **DOWNLOAD** THE COMPLETE MANUAL

5. OTHERS

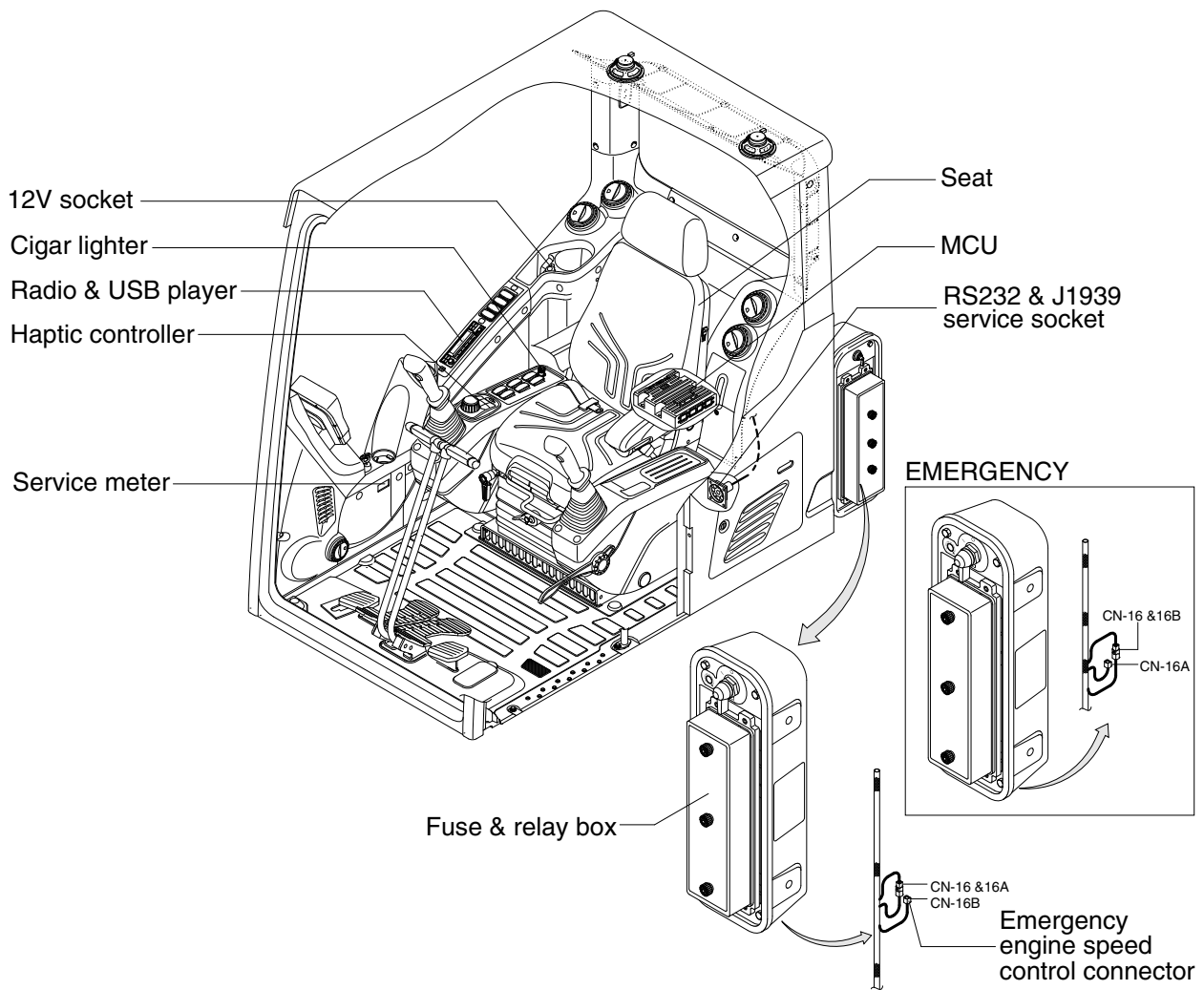

380A3CD24

1) CIGAR LIGHTER

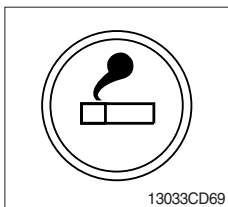

- (1) This can be used when the engine starting switch is ON.
- (2) The lighter can be used when it springs out in a short while after being pressed down.

※ **Service socket**

**Use cigar lighter socket when you need emergency power.
Do not use the lighter exceeding 24 V, 100 W.**

■AUX OPERATION

It is possible to connect your portable media player to the audio system for playback of the audio tracks via the cab speakers.

To get the best results when connecting the portable media to the audio system, follow these steps :

- Use a 3.5 mm stereo plug cable to connect the media player headphone socket at each end as follows.
 - Adjust the portable media player to approximately 3/4 volume and start playback.
 - Press the MODE button (3) on the audio unit to change into AUX mode.
 - The volume and tone can now be adjusted on the audio unit to the desired level.
- ※ **The audio quality of your media player and the audio tracks on it may not be of the same sound quality as the audio system is CD Player.**
 - ※ **If the sound of the media player is too low compared with the radio or CD, increase the volume of the player.**
 - ※ **If the sound of the media player is too loud and/or distorted, decrease the volume of the player.**
 - ※ **When in AUX mode, only the Volume, Bass, Treble, EQ and Mode functions of the audio unit can be used.**

④ Slide choice menu



300A3CD163A

- You can increase or decrease the slide choice bar.

⑤ Level choice menu



300A3CD164A

- You can increase or decrease the level choice bar.

⑥ Push button

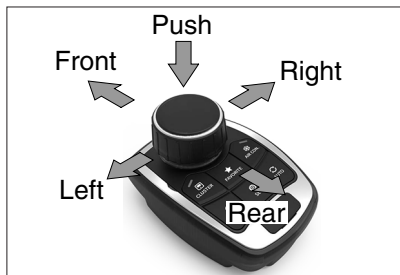

300A3CD165

- **Push** : Select the current menu or the pop-up warning lamp moves to the original position when warning lamp occurs.
- **Left** : ESC
- **Right** : CAM
- **Front** : Cluster main menu
- **Rear** : Return to acceleration mode

8) EMERGENCY ENGINE SPEED CONTROL CONNECTOR

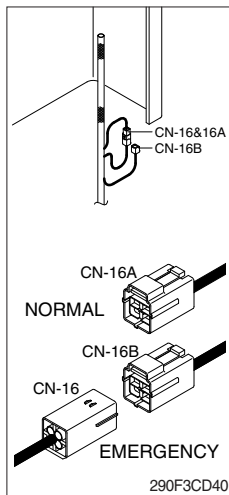

(1) When the CAN communication between the ECM and the MCU is abnormal due to malfunction, change the CN-16 connection from CN-16A to CN-16B and then control the engine speed by rotating the multimodal module of the jog dial module.

※ **Never connect connector CN-16 with CN-16B when MCU is in normal operation.**

※ **Make repair as soon as possible.**

9) SERVICE METER

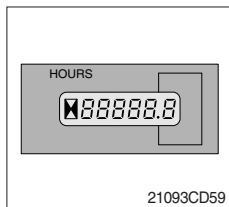

(1) This meter shows the total operation hours of the machine.

(2) Always ensure the operating condition of the meter during the machine operation. Inspect and service the machine based on hours as indicated in chapter 6, maintenance.

10) MCU/ECM CONNECTOR

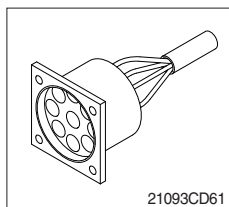

(1) MCU communicates the machine data with Laptop computer through the connector.

(2) ECM communicates the engine data with cummins INSITE adapter through the connector.

① ECM fault code check

② ECM program change

③ Engine data monitoring & test

11) 12V SOCKET

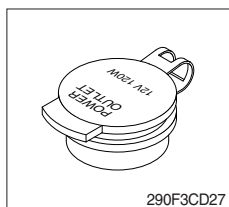

(1) Utilize the power of 12 V as you need and do not exceed 12 V, 30 W.

3. FUEL, COOLANT AND LUBRICANTS

1) NEW MACHINE

New machine used and filled with following lubricants.

Description	Specification
Engine oil (API CK-4)	SAE 15W-40, ★SAE 5W-40
DEF/AdBlue®	ISO 22241 (32.5% high-purity urea and 67.5% deionized water)
Hydraulic oil	HD Hyundai Construction Equipment genuine long life (ISO VG 32, VG 46, VG 68) Conventional (ISO VG 15★) HD Hyundai Construction Equipment Bio Hydraulic Oil (HBHO, ISO VG 46)
Swing and travel reduction gear	SAE 80W-90 (GL-4/GL-5)
Grease	Lithium base grease NLGI No. 2
Fuel	ASTM D975-No. 2, Ultra low sulfur diesel
Coolant (DCA4)	ASTM D6210 Mixture of 50% ethylene glycol base antifreeze and 50% water. Mixture of 60% ethylene glycol base antifreeze and 40% water.★

SAE : Society of Automotive Engineers

API : American Petroleum Institute

ISO : International Organization for Standardization

NLGI : National Lubricating Grease Institute

ASTM : American Society of Testing and Material

DEF : Diesel Exhaust Fluid

DEF compatible with AdBlue®

DCA4 : Brand name of Chemical Additive

manufactured by the Cummins Fleetguard Co

Ultra low sulfur diesel

- sulfur content ≤ 15 ppm

★Cold region

Russia, CIS, Mongolia

※ Refer to the page 7-41 for further information of recommended oils.

6. SERVICE INSTRUCTION

1) CHECK ENGINE OIL LEVEL

Check the oil level with the machine on flat ground before starting engine.

- (1) Pull out the dipstick and wipe with a clean cloth.
- (2) Check the oil level by inserting the dipstick completely into the hole and pulling out again.
- (3) If oil level is LOW, add oil and then check again.
 - ※ If the oil is contaminated or diluted, change the oil regardless of the regular change interval.
 - ※ Check oil level after engine has been stopped for 15 minutes.
 - ▲ Do not operate unless the oil level is in the normal range.
 - ※ Keep all parts clean from contaminants. Contaminants may cause rapid wear and shortened component life.

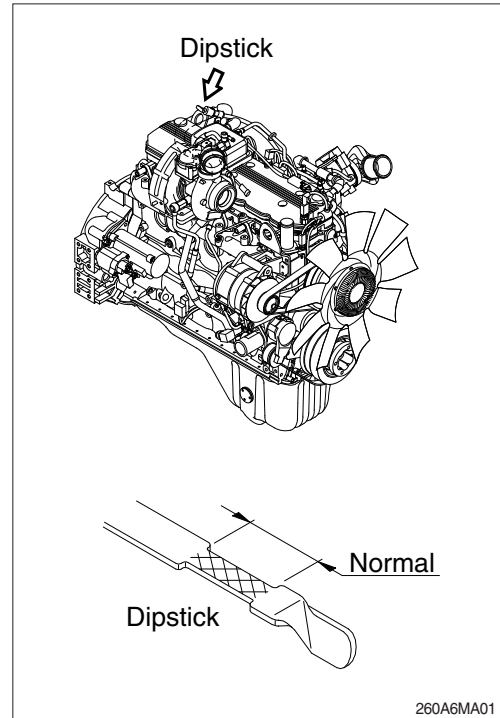

2) REPLACEMENT OF ENGINE OIL AND OIL FILTER

- (1) Operate the engine until the coolant temperature reaches 60°C (140°F). Shut off the engine.
- (2) Remove the oil drain plug. Drain the oil immediately to be sure all the oil and suspended contaminants are removed from the engine.
 - ※ A drain pan with a capacity of 30 liters (7.9 U.S. gallons) will be adequate.
 - ※ Dispose of the waste oil in accordance with local regulations.
- (3)
- (4)
- (5)
 - ※ The O-ring can stick on the filter head. Be sure it is removed before installing the new filter.

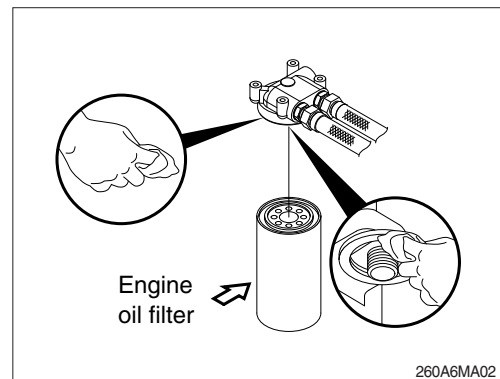
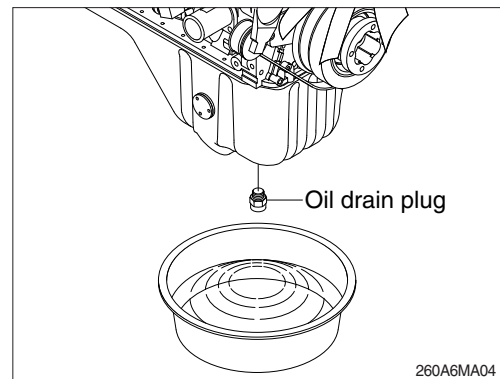

13) CHARGE AIR PIPING

- (1) Inspect the charge air piping and hoses for leaks, holes, cracks, or loose connections.
- (2) Tighten the hose clamps if necessary.

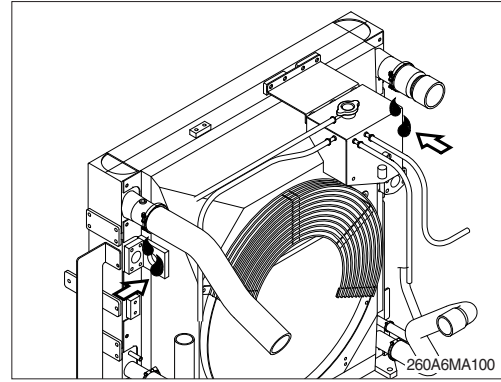

14) REPLACEMENT OF FUEL FILTER ELEMENT

- (1) Use 1" wrench, loosen and remove the element and clean the gasket surface.
 - ※ **Make sure O-ring does not stick to filter head. Remove O-ring with screwdriver if necessary.**
- (2) Lubricate O-ring of a new element with clean lubricating oil.
- (3) Install the new element on the filter head. Tighten the new element until the gasket contacts the filter head surface. Tighten the new element an additional 3/4 turn after contact.
 - ※ **Mechanical overtightening can distort the threads or damage the filter element seal.**
- (4) Relieve the air after mounting.
 - ※ **Do not pre-fill the new element with fuel. The system must be primed after the new element is installed. Pre-filling the new element can result in debris entering the fuel system and damaging fuel system components.**
 - ※ **Check for fuel leakage after the engine starts. If air is in the fuel system, the engine will not start. Start engine after bleeding the air according to the method of bleeding air.**

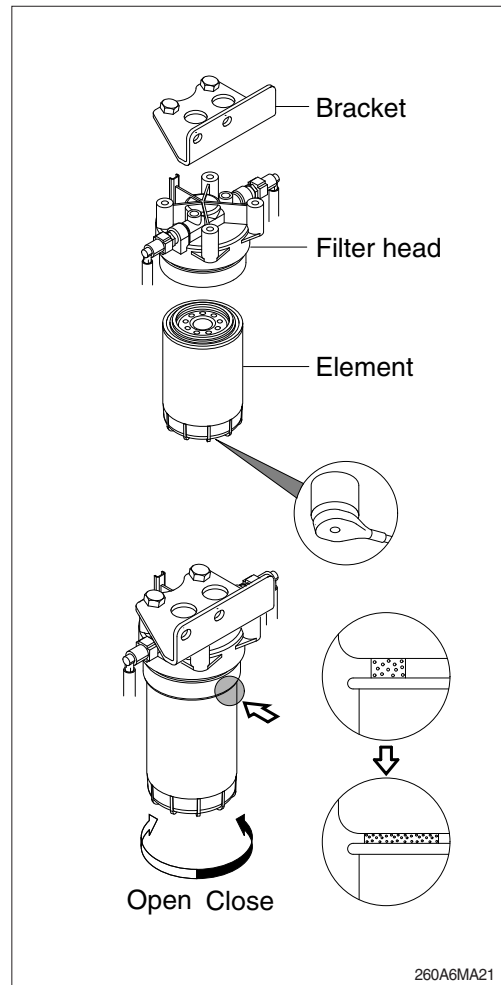

24) HYDRAULIC OIL CHECK

- (1) Position the machine as shown in the illustration on the right. Then stop engine.
- (2) Check the oil level at the level gauge of hydraulic oil tank.
- (3) The oil level is normal if the oil is between the red lines. The oil level depends on the temperature of the hydraulic oil. Refer to the height (A) in the below table to check the level gauge.

Temperature		Height A	
°C	°F	mm	inch
0	32	15	0.6
10	50	25	1.0
20	68	30	1.2
30	86	35	1.4
40	104	40	1.6

- ※ Refer to page 3-25 for checking the temperature of the hydraulic oil.
- ※ Add the hydraulic oil, if necessary.

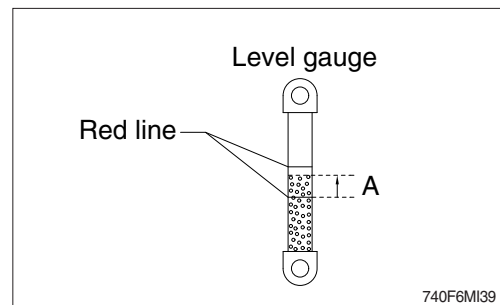
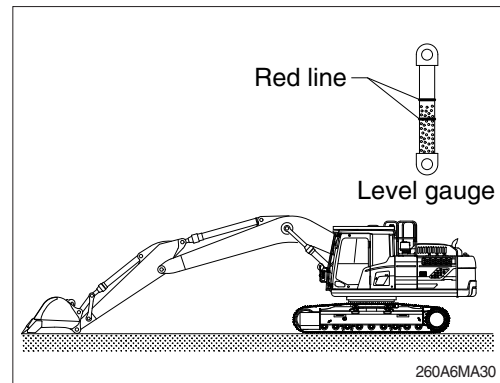

25) FILLING HYDRAULIC OIL

- (1) Position the machine like the hydraulic oil check. Then stop engine.
- (2) Relieve the pressure in the tank by pushing the top of the air breather.
- (3) Loosen the socket bolts and remove the air breather on the top of oil tank and fill the oil to the specified level.
 - Tightening torque : $4.05 \pm 0.8 \text{ kgf} \cdot \text{m}$
($29.3 \pm 5.8 \text{ lbf} \cdot \text{ft}$)
- (4) Start engine after filling and operate the work equipment several times.
- (5) Check the oil level at the level check position after engine stops.

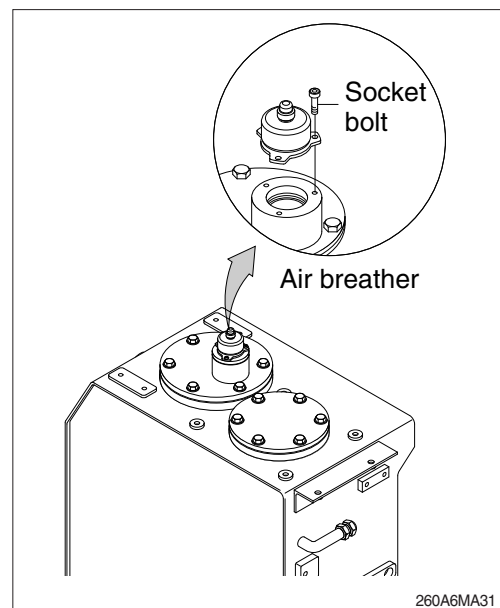

42) ADJUSTMENT OF BUCKET CLEARANCE

- (1) Lower the bucket on the ground as shown in the illustration.
- (2) Swing to the left and keep arm boss in contact with the left bucket ear.
- (3) Lock the safety knob to the LOCK position and stop the engine.
- (4) Measure the clearance (A) between bucket and arm boss. This is the total clearance.

(5) Adjusting

- ① Loosen bolt (2), and remove washer (3), plate (1) and shim (4).
- ② Remove the shim equivalent value with measuring value.
- ③ Assemble the parts in the reverse order of removal.
 - Tightening torque : 29.6 ± 3.2 kgf · m
(214.0 ± 23.1 lbf · ft)
 - Normal clearance : 0.5 ~ 1.0 mm
(0.02 ~ 0.04 in)

※ If the bucket is not adjusted correctly, noise and vibration will occur. This will also cause damage to O-ring and bushings prematurely.

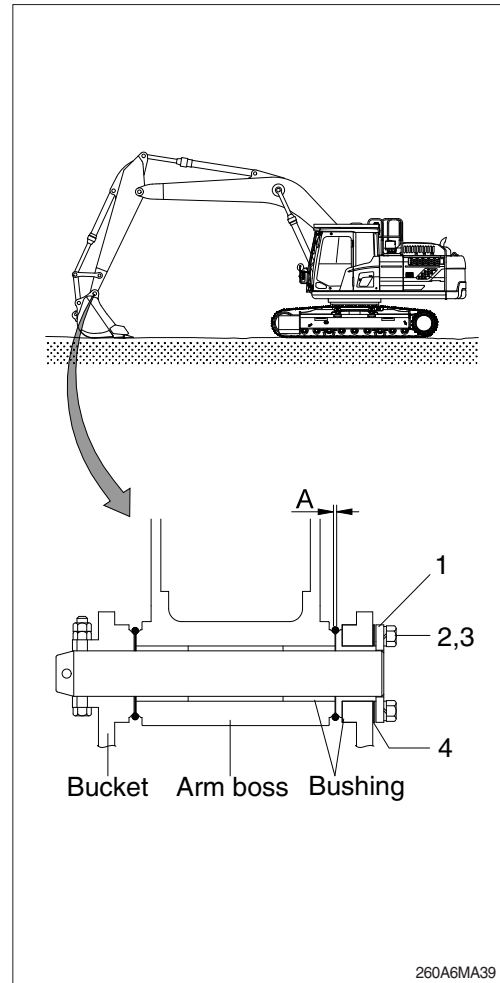

(5) Boom cylinder

Mark	Description	Unit	Specification
L	Length	mm (ft-in)	2100 (6' 11")
H	Height	mm (ft-in)	240 (0' 9")
W	Width	mm (ft-in)	380 (1' 3")
Wt	Weight	kg (lb)	240 (530)

※ Including piping.

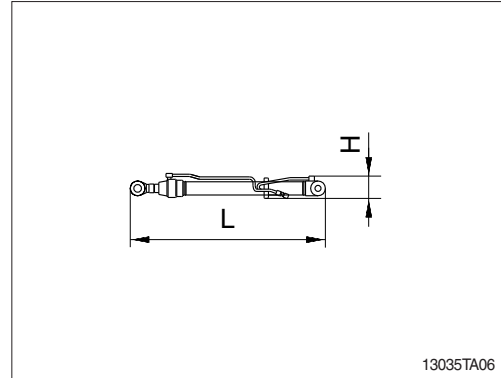

(6) Cab assembly

Mark	Description	Unit	Specification
L	Length	mm (ft-in)	1950 (6' 5") [2070 (6' 10")]
H	Height	mm (ft-in)	1780 (5' 10") [1822 (6' 0")]
W	Width	mm (ft-in)	1104 (3' 7") [1126 (3' 8")]
Wt	Weight	kg (lb)	495 (1092) [650 (1433)]

[] : with FOG GUARD

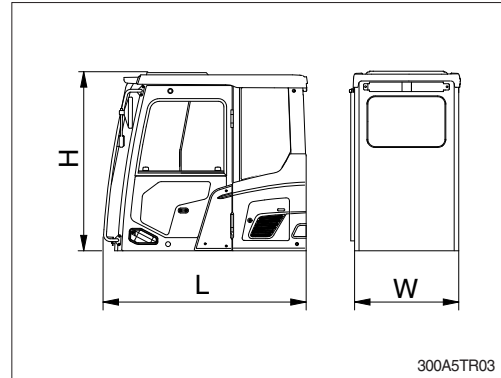

(7) Counterweight

Mark	Description	Unit	Specification
L	Length	mm (ft-in)	2840 (9' 4")
H	Height	mm (ft-in)	530 (1' 9")
W	Width	mm (ft-in)	1255 (4' 1")
Wt	Weight	kg (lb)	4600 (10410)

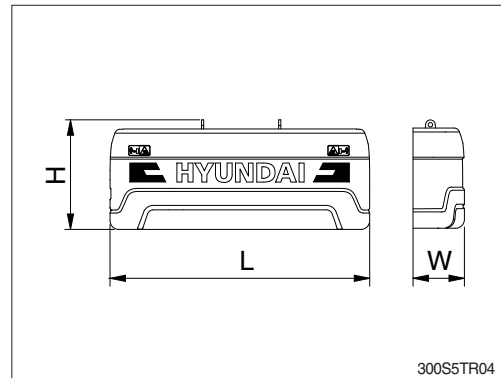

3. OTHERS

Trouble	Service	Remark
Track slips out of place. Excessive wear of the sprocket.	<ul style="list-style-type: none">· Adjust tension of track.	
Bucket either rises slowly or not at all.	<ul style="list-style-type: none">· Add oil to specified level.	
Slow speed of travel, swing, boom, arm and bucket.	<ul style="list-style-type: none">· Add oil to specified level.	
Unusual noise emitted from pump.	<ul style="list-style-type: none">· Clean the hydraulic tank strainer.	
Excessive oil temperature rise of hydraulic oil.	<ul style="list-style-type: none">· Clean and check the oil cooler.· Adjust fan belt tension.· Add oil to specified level.	

4. WEIGHT

Item	HX260A L		HX260A NL		HX260A HW	
	kg	lb	kg	lb	kg	lb
Upperstructure assembly						
· Main frame weld assembly	2426	5437	2426	5437	2443	5386
· Engine assembly	583	1285	583	1285	583	1285
· Aftertreatment assembly	74	162	74	162	74	162
· Main pump assembly	140	309	140	309	140	309
· Main control valve assembly	220	485	220	485	220	485
· Swing motor assembly	378	833	378	833	378	833
· Hydraulic oil tank WA	174	384	174	384	174	384
· Fuel tank WA	216	476	216	476	216	476
· Counterweight	4600	10141	6100	13448	4600	10141
· Cab assembly	495	1092	495	1092	495	1092
Lower chassis assembly						
· Track frame weld assembly	2927	6453	2829	6237	5134	11318
· Swing bearing	364	802	364	802	364	802
· Travel motor assembly (2EA)	617	1360	617	1360	886	1953
· Turning joint	53	117	53	117	53	117
· Sprocket (2EA)	103	227	103	227	166	367
· Track recoil spring (2EA)	326	720	326	720	450	992
· Idler (2EA)	301	664	301	664	499	1100
· Upper roller (4EA)	82	182	82	182	216	477
· Lower roller (18EA)	855	1885	855	1885	973	2144
· Track-chain assembly (600 mm triple grouser shoe) (2EA)	3000	6614	3000	6614	3759	8287
· Track-chain assembly (700 mm triple grouser shoe) (2EA)	3295	7264	3295	7264	-	-
· Track-chain assembly (800 mm triple grouser shoe) (2EA)	3590	7914	3590	7914	-	-
· Track-chain assembly (900 mm triple grouser shoe) (2EA)	3884	8564	-	-	-	-
· Track-chain assembly (700 mm double grouser shoe) (2EA)	3884	8564	-	-	5237	11546
Front attachment assembly						
· 5.85 m boom assembly	1940	4277	1940	4277	1940	4277
· 3.05 m arm assembly	1020	2249	1020	2249	1020	2249
· 1.08 m³ SAE heaped bucket	1020	2249	1020	2249	1020	2249
· Boom cylinder assembly (2EA)	473	1044	473	1044	473	1044
· Arm cylinder assembly	334	736	334	736	334	736
· Bucket cylinder assembly	206	453	206	453	206	453
· Bucket control linkage total	280	617	280	617	280	617
· 5.90 m boom assembly (2-piece)	2295	5060	2295	5060	2295	5060
· Boom cylinder assembly (2EA, 2-piece)	473	1044	473	1044	473	1044
· Arm cylinder assembly (2-piece)	334	736	334	736	334	736
· Boom cylinder assembly (2-piece)	206	453	206	453	206	453
· Adjust boom cylinder assembly (2-piece)	295	651	295	651	295	651

※ This information is different with operating and transportation weight because it is not including harness, pipe, oil, fuel so on.









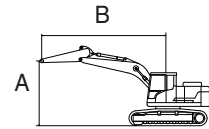

※ Refer to Transportation for actual weight information and Specifications for operating weight.

Model	Type	Boom	Arm	Counterweight	Shoe	Wheel	Dozer		Outrigger	
		Length [mm]	Length [mm]	weight [kg]	width [mm]	width [mm]	Front	Rear	Front	Rear
HX260A NL	MONO BOOM	5850	2500	6100	600	-	-	-	-	-

·  : Rating over-front

·  : Rating over-side or 360 degree



Lift-point height (A)	Lift-point radius (B)								At max. reach			
	3.0 m (9.8 ft)		4.5 m (14.8 ft)		6.0 m (19.7 ft)		7.5 m (24.6 ft)		Capacity		Reach	
											m (ft)	
7.5 m (24.6 ft)	kg									*6100	*6100	5.96
	lb									*13450	*13450	(19.5)
6.0 m (19.7 ft)	kg				*6480	*6480				*5660	5500	7.11
	lb				*14290	*14290				*12480	12130	(23.3)
4.5 m (14.8 ft)	kg		*8510	*8510	*7190	7050	*6690	4980	*5580	4650	7.81	
	lb		*18760	*18760	*15850	15540	*14750	10980	*12300	10250	(25.6)	
3.0 m (9.8 ft)	kg		*11010	10130	*8300	6710	*7140	4840	*5730	4240	8.17	
	lb		*24270	22330	*18300	14790	*15740	10670	*12630	9350	(26.8)	
1.5 m (4.9 ft)	kg		*13080	9520	*9400	6410	7580	4700	*6130	4100	8.25	
	lb		*28840	20990	*20720	14130	16710	10360	*13510	9040	(27.1)	
0.0 m (0.0 ft)	kg		*13970	9260	*10120	6210	7460	4590	6760	4180	8.04	
	lb		*30800	20410	*22310	13690	16450	10120	14900	9220	(26.4)	
-1.5 m (-4.9 ft)	kg	*11300	*11300	*13880	9220	*10260	6140	7460	4580	7420	4560	7.53
	lb	*24910	*24910	*30600	20330	*22620	13540	16450	10100	16360	10050	(24.7)
-3.0 m (-9.8 ft)	kg	*17940	*17940	*12860	9350	*9540	6230			*8300	5470	6.64
	lb	*39550	*39550	*28350	20610	*21030	13730			*18300	12060	(21.8)
-4.5 m (-14.8 ft)	kg	*14190	*14190	*10200	9690					*8510	7970	5.17
	lb	*31280	*31280	*22490	21360					*18760	17570	(17.0)

Note 1. Lifting capacity are based on ISO 10567.

- Lifting capacity of the HX series does not exceed 75% of tipping load with the machine on firm level ground or 87% of full hydraulic capacity.
- The Lift-point is bucket pivot mounting pin on the arm (without bucket mass).
- *Indicates load limited by hydraulic capacity.

※ Lifting capacities are based upon a standard machine conditions.

Lifting capacities will vary with different work tools, ground conditions and attachments.

The difference between the weight of a work tool attachment must be subtracted.

Consult with your local HD Hyundai Construction Equipment dealer regarding the lifting capacities for specific work tools and attachments.

▲ Failure to comply to the rated load can cause serious injury, death, or property damage. Make adjustments to the rated load as necessary for non-standard configurations.

6. BUCKET SELECTION GUIDE

1) HX260A L, 4600 KG COUNTERWEIGHT



General bucket



Heavy duty
(without side cutter)



Heavy duty
(with side cutter)



Rock heavy duty

Type	Capacity		Width mm (in)	Weight kg (lb)	Tooth EA	MONO				2-PIECE		
	SAE Heaped m ³ (yd ³)	CECE heaped m ³ (yd ³)				Recommendation						
						5.85 m (19' 2") Boom				5.90 m (19' 5") Boom		
						2.1 m (6' 11") Arm	2.5 m (8' 2") Arm	3.05 m (10' 0") Arm	3.60 m (11' 10") Arm	2.1 m (6' 11") Arm	2.5 m (8' 2") Arm	3.05 m (10' 0") Arm
General bucket	1.08 (1.41)	0.95 (1.24)	1170 (46.1")	1020 (2250)	5	●	●	●	◐	●	●	●
	1.27 (1.66)	1.11 (1.45)	1325 (52.2")	1100 (2430)	5	●	●	◐	■	●	◐	■
	1.50 (1.96)	1.30 (1.70)	1515 (59.6")	1180 (2600)	5	◐	◐	■	▲	◐	■	▲
Heavy duty	1.27 (1.66)	1.11 (1.45)	1380 (54.3")	1290 (2840)	5	●	◐	◐	■	●	◐	■
	1.46 (1.91)	1.28 (1.67)	1535 (60.4")	1380 (3040)	6	◐	■	■	▲	◐	■	▲
Rock heavy duty	1.16 (1.52)	1.00 (1.31)	1285 (50.6")	1380 (3040)	5	●	●	◐	X	●	◐	■

●	Applicable for materials with density of 2100 kg/m ³ (3500 lb/yd ³) or less
◐	Applicable for materials with density of 1800 kg/m ³ (3000 lb/yd ³) or less
■	Applicable for materials with density of 1500 kg/m ³ (2500 lb/yd ³) or less
▲	Applicable for materials with density of 1200 kg/m ³ (2000 lb/yd ³) or less
X	Not recommended

※ These recommendations are for general conditions and average use.

Work tools and ground conditions have effects on machine performance.

Select an optimum combination according to the working conditions and the type of work that is being done.

Consult with your local HD Hyundai Construction Equipment dealer for information on selecting the correct boom–arm–bucket combination.

HYDRAULIC BREAKER AND QUICK COUPLER

1. SELECTING HYDRAULIC BREAKER

※ **Read safety hints in this manual and breaker & quick coupler manuals in website (Dealer Portal) before using breaker and quick coupler.**

- 1) Become familiar with the manual and select breakers suitable to machine specifications.
- 2) Make careful selection in consideration of oil quantity, pressure and striking force, to enable satisfied performance.
- 3) When apply a breaker to the machine, consult your local dealer of HD Hyundai Construction Equipment for further explanation.

CLICK HERE TO **DOWNLOAD** THE COMPLETE MANUAL

- Thank you very much for reading the preview of the manual.
- You can download the complete manual from: www.heydownloads.com by clicking the link below



- Please note: If there is no response to CLICKING the link, please download this PDF first and then click on it.

CLICK HERE TO **DOWNLOAD** THE COMPLETE MANUAL