

# **HW250 MH**

Material Handler & Orange Grapple

This manual contains 2 contents as Material Handler and Orange Grapple.

CLICK HERE TO **DOWNLOAD** THE COMPLETE MANUAL

- Thank you very much for reading the preview of the manual.
- You can download the complete manual from: [www.heydownloads.com](http://www.heydownloads.com) by clicking the link below



- Please note: If there is no response to CLICKING the link, please download this PDF first and then click on it.

CLICK HERE TO **DOWNLOAD** THE COMPLETE MANUAL

---

## 1-5. Safety Bar (Option, Europe only)

### System to prevent from falling out from the cabin.

The machine is provided with an additional system to prevent the operator falling from the cabin when the cabin is not in the lowered position.

This prevention system is located on the left side of the cabin, and consists of Safety bar which functions together with the standard security lever. (see the Standard manual)

When the Safety bar of the elevated cabin is pushed down and the standard security lever is pulled up, the machine functions normally.

The two levers must be placed horizontally for the machine to operate.

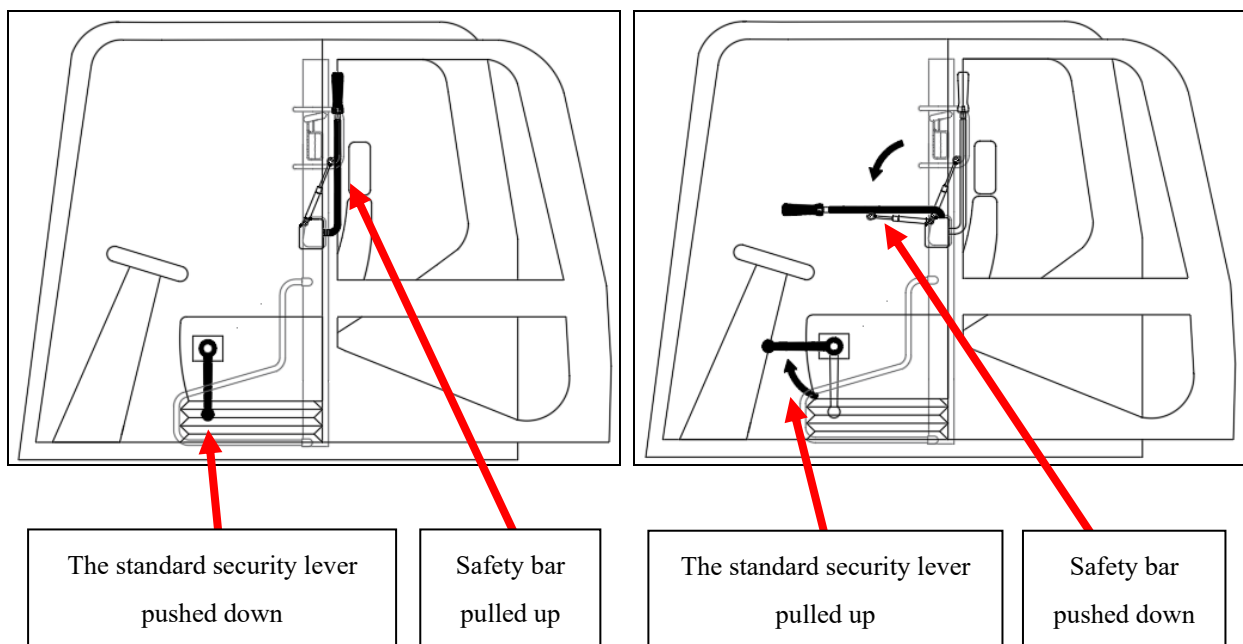

If either of the two levers is not engaged, no functions will be activated.

If the operator has to escape the cockpit for urgent reasons while the cabin is raised, the operator must unlock the guard at their own risk and peril, by pushing down the standard security lever.

### 3-3. Electric Circuit Diagram

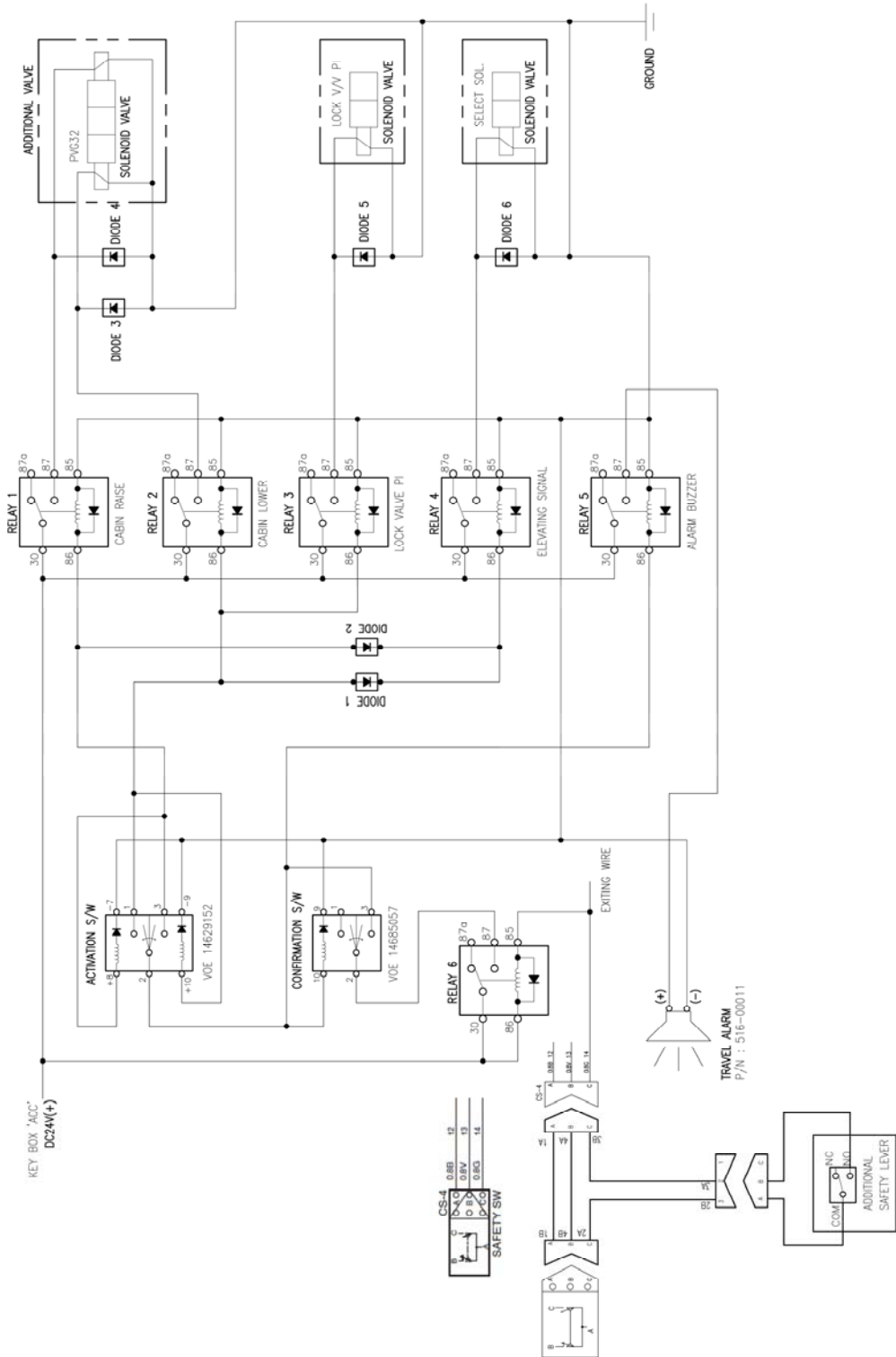

---

---

## Contents of Orange Grapple

1	Safety -----	05
1.1	Safety assurance -----	05
1.2	Symbol mark of “Safety Caution” -----	05
1.3	Safety Alert Symbol -----	05
1.4	Cautions for basic items -----	05
1.5	Hazard Operation -----	08
2	Specifications -----	09
2.1	Hydraulic Cylinder -----	09
2.2	Dimensions -----	10
3	Structure & Installation -----	11
3.1	Name of each part -----	11
3.2	Installation to Arm -----	12
4	Check and Maintenance -----	15
4.1	General items -----	15
4.2	Directions when checking or having maintenance -----	15
4.3	Preparations before starting repair -----	15
4.4	Regular replacement of major parts -----	16
4.5	Locations where greases are to be inserted -----	16

3) Connect hydraulic hoses to arm

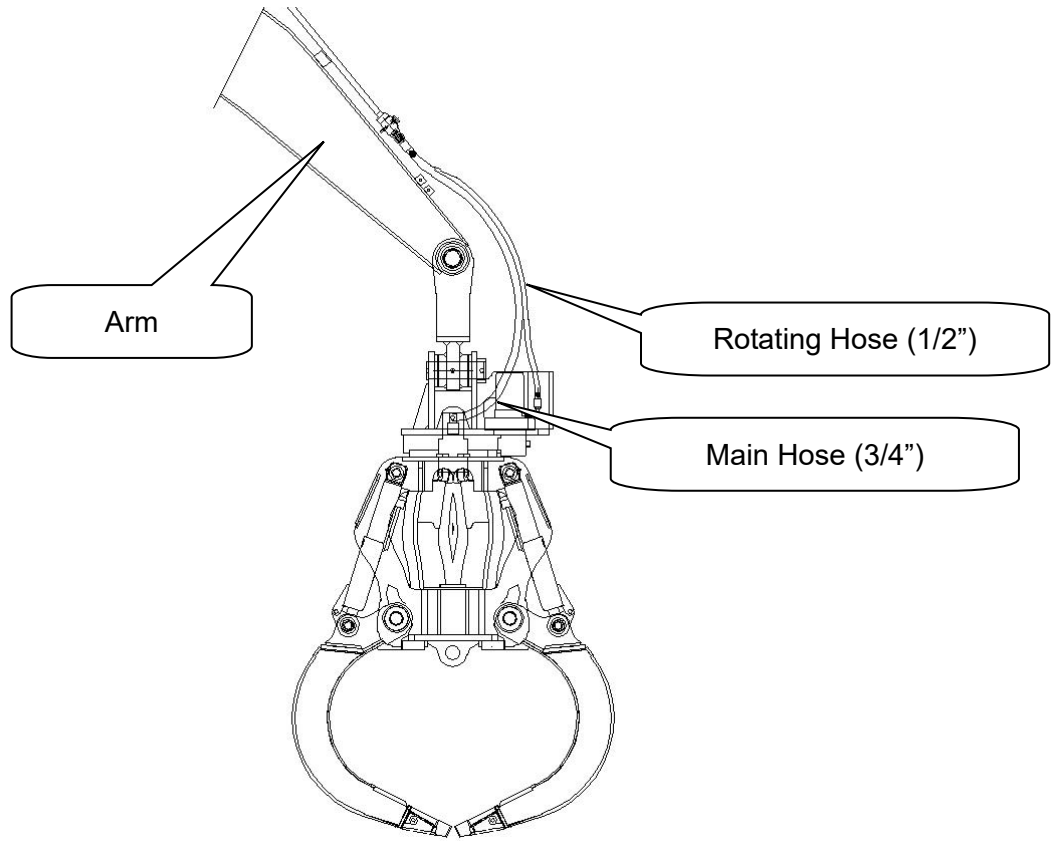

4) Hydraulic circuit diagram

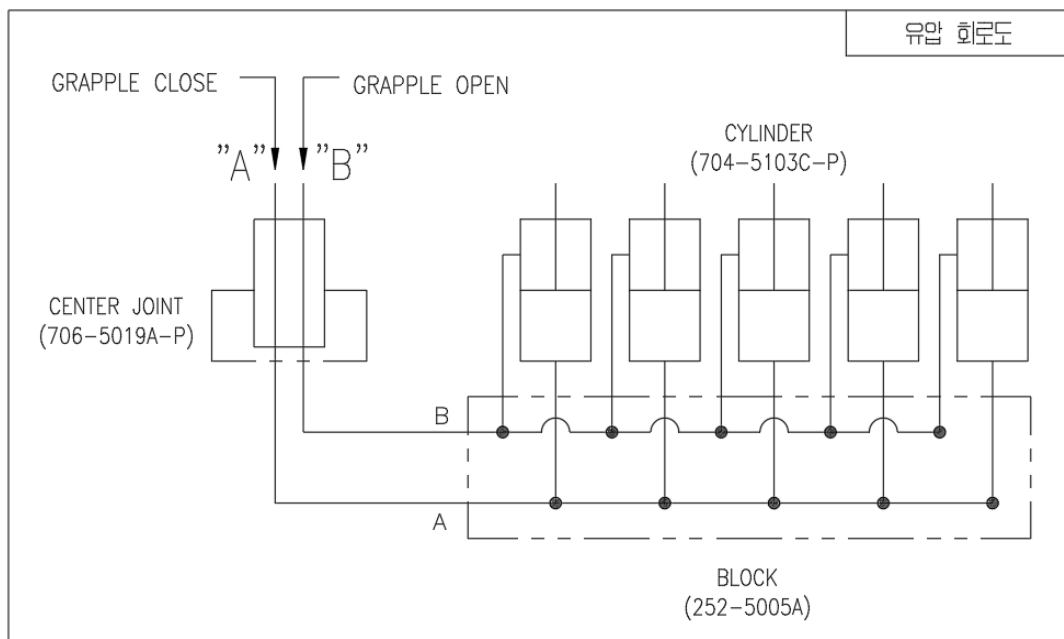

# HYDRAULIC PARTS INSTALLATION

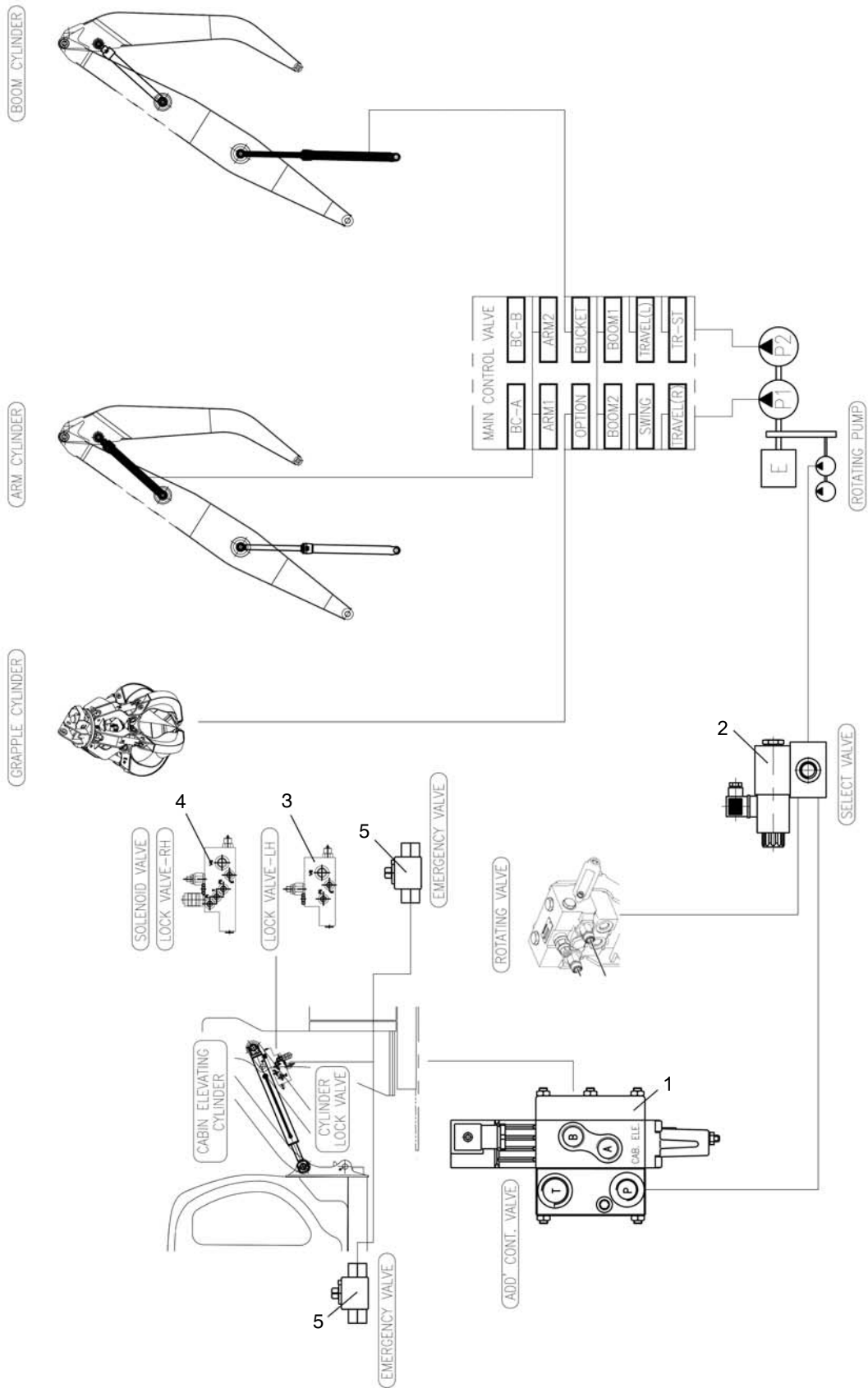

CLICK HERE TO **DOWNLOAD** THE COMPLETE MANUAL

- Thank you very much for reading the preview of the manual.
- You can download the complete manual from: [www.heydownloads.com](http://www.heydownloads.com) by clicking the link below



- Please note: If there is no response to CLICKING the link, please download this PDF first and then click on it.

CLICK HERE TO **DOWNLOAD** THE COMPLETE MANUAL

# BOOM GREASE PIPING

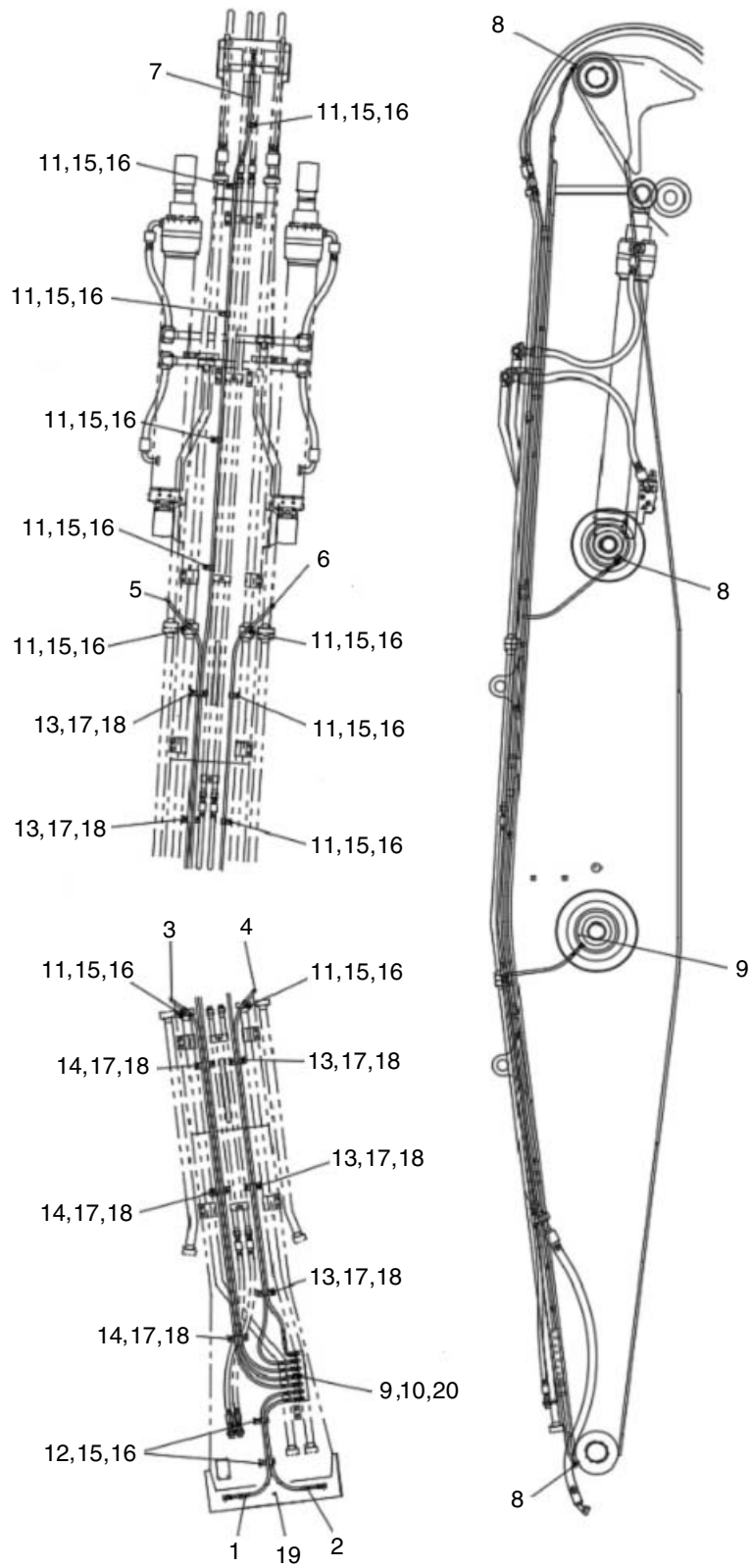

# GREASE PIPING (ELEVATED CABIN)

## 1. GREASE PIPING (BED FRAME)

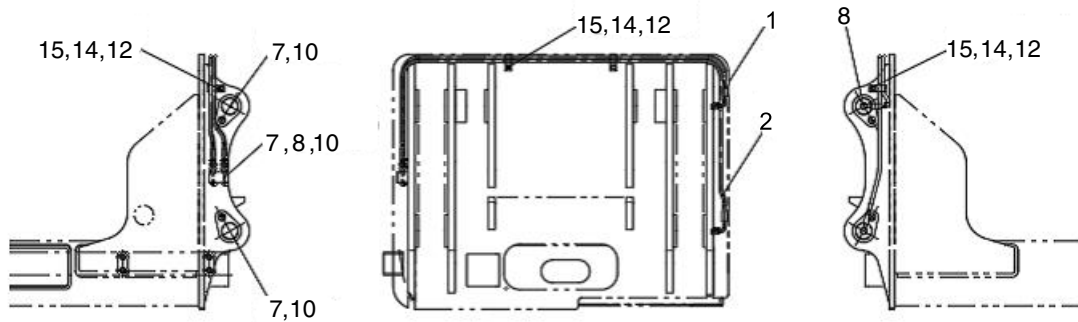

## 2. GREASE PIPING (SUPPORT FRAME)

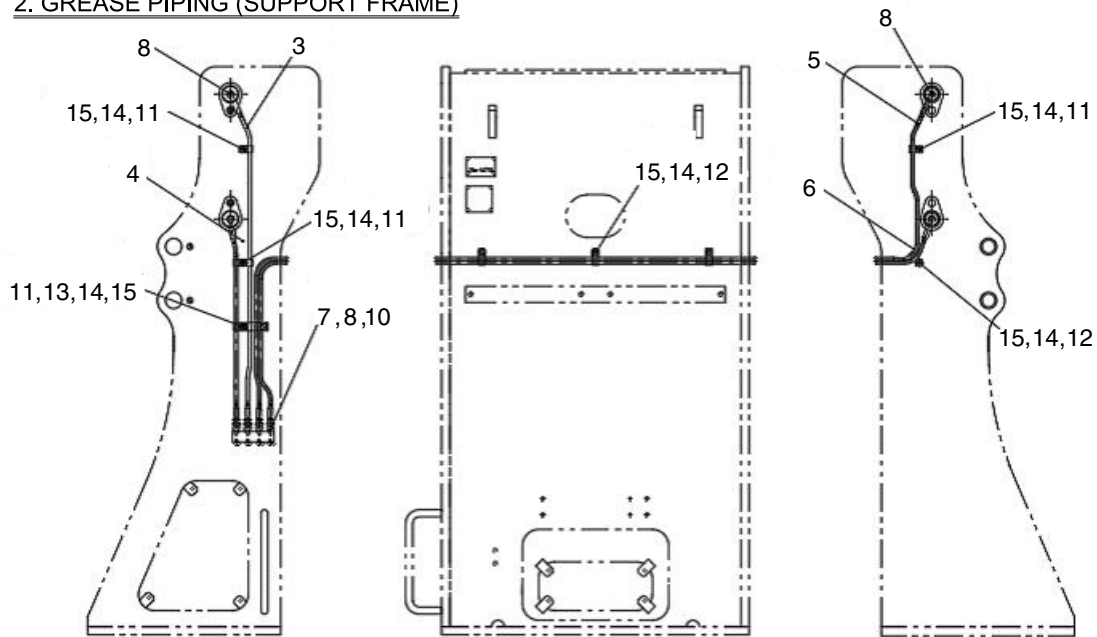

# CABIN ELEVATING ASSEMBLY (3/3)

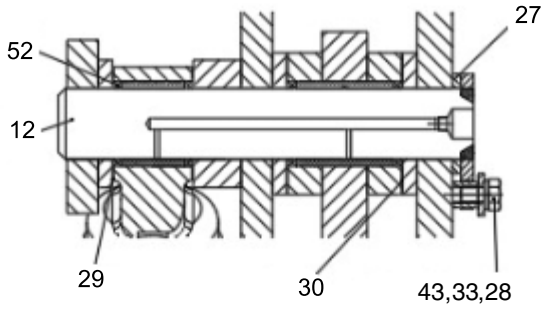

SECTION E

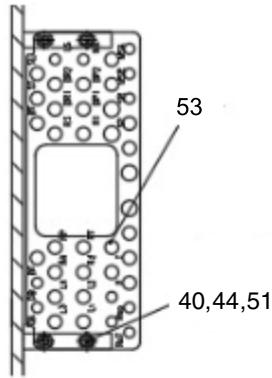

VIEW F

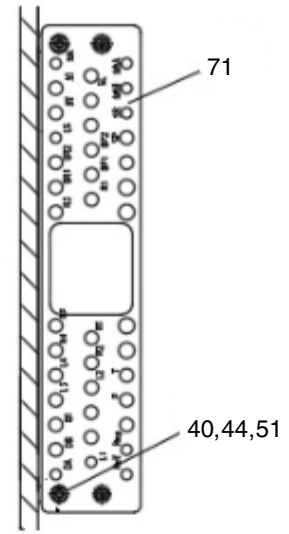

VIEW G

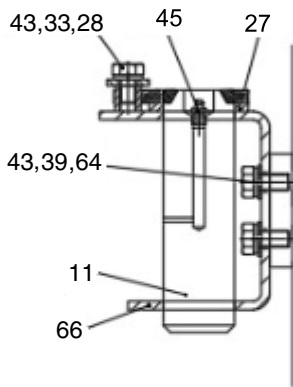

SECTION H

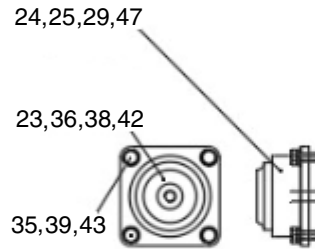

VIEW J

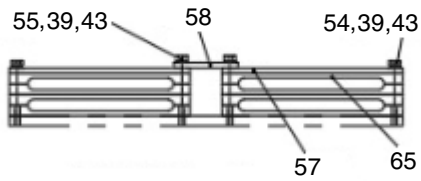

SECTION K

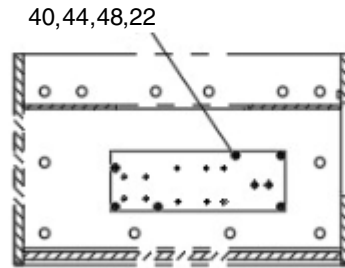

SECTION L

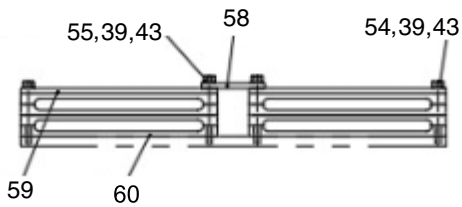

SECTION M

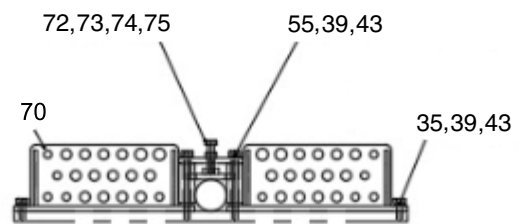

SECTION N



# BOOM ASSEMBLY

HW250 MH

ITEM	PART NO	DESCRIPTION	QTY	SERIAL NO	ITC	REMARK
*	XKDA-00969	BOOM ASSY	1			
1-1	XKDA-00971	. BUSHING	2			
1-2	XKDA-00184	. BUSHING	2			
2	XKDA-00972	PIN	1			
3	XKDA-00973	SHIM-1.0	2			
4	S993-080140	SHIM-POLYMER 2.0	4			
5	S991-080140	SHIM-POLYMER 1.0	2			
6	XKDA-00974	SHIM-1.0	2			
7	XKDA-00975	SHIM-1.0	4			
8	XKDA-00976	SEAL-DUST	4			
9	XKDA-00977	SEAL-DUST	4			
11	61Q6-00320	STOPPER-PIN	2			
12	S017-161606	BOLT-HEX	2			
13	S205-16100B	NUT-HEX	4			
14	XKDA-00978	STOPPER	2			
15	XKDA-00979	BOLT-HEX	2			
16	XKDA-00980	NUT-HEX	4			
17	XKDA-00981	LAMP-WORKING	2			
18	XKDA-00900	BOLT-HEX	2			
19	XKDA-00050	WASHER-SPRING	2			
20	XKDA-00982	BRACKET	2			
21	XKDA-00746	BOLT-HEX	2			
22	XKDA-00049	WASHER-SPRING	2			
23	XKDA-00983	HARNESS-WIRE	1			
24	XKDA-00411	CLIP	2			
25	XKDA-00841	BOLT-HEX	2			
26	XKDA-00171	WASHER-SPRING	2			

# UPPER STRUCTURE ASSEMBLY

HW250 MH

ITEM	PART NO	DESCRIPTION	QTY	SERIAL NO	ITC	REMARK
2	XKDA-01249	BODY- MAIN	1			
3	XKDA-01250	BEARING -SWING	1			
5	XKDA-01252	STOPPER	2			
6	XKDA-01253	PIN	2			
7	XKDA-01254	BOLT-HEX	4			
8	XKDA-01255	BOLT-HEX	4			
9	XKDA-01256	BOLT-HEX	14			
10	XKDA-01257	BOLT-HEX	12			
11	XKDA-01258	WASHER -PLAIN	8			
12	XKDA-01259	WASHER -SPRING	8			
13	XKDA-00124	FITTING -GREASE	2			
14	XKDA-01260	ADAPTER	2			
15	XKDA-01261	BOLT-SOCKET	2			

CLICK HERE TO **DOWNLOAD** THE COMPLETE MANUAL

- Thank you very much for reading the preview of the manual.
- You can download the complete manual from: [www.heydownloads.com](http://www.heydownloads.com) by clicking the link below



- Please note: If there is no response to CLICKING the link, please download this PDF first and then click on it.

CLICK HERE TO **DOWNLOAD** THE COMPLETE MANUAL