

# CONTENTS

EC declaration of conformity .....	0-1	9. Operation in the special work sites .....	4-23
Foreword .....	0-2	10. Storage .....	4-25
Before servicing this machine .....	0-3	11. Regeneration system .....	4-27
Table to enter S/No and distribution .....	0-4		
EC regulation approved .....	0-5	<b>5. TRANSPORTATION</b>	
Safety labels .....	0-6	1. Road traveling .....	5-1
Machine data plate .....	0-15	2. Preparation for transportation .....	5-2
Guide (direction, S/No, symbol) .....	0-16	3. Loading the machine .....	5-3
		4. Fixing the machine .....	5-4
<b>1. SAFETY HINTS</b>		5. Loading and unloading by crane .....	5-6
1. Before operating the machine .....	1-1	6. Towing the machine .....	5-7
2. During operating the machine .....	1-15		
3. During maintenance .....	1-24	<b>6. MAINTENANCE</b>	
4. Parking .....	1-28	1. Instructions .....	6-1
		2. Tightening torque .....	6-5
<b>2. SPECIFICATIONS</b>		3. Spec of fuel, coolant and lubricants .....	6-8
1. Major components .....	2-1	4. Maintenance check list .....	6-10
2. Specifications .....	2-2	5. Maintenance chart .....	6-13
3. Weight .....	2-6	6. Service instruction .....	6-15
4. Specification for major components .....	2-7	7. Electrical system .....	6-46
		8. Air conditioner and heater .....	6-49
<b>3. CONTROL DEVICES</b>			
1. Cab devices .....	3-1	<b>7. TROUBLESHOOTING GUIDE</b>	
2. Cluster .....	3-2	1. Engine .....	7-1
3. Monitors .....	3-13	2. Electrical system .....	7-2
4. Switches .....	3-34	3. Power train system .....	7-3
5. Control device .....	3-42	4. Hydraulic system .....	7-4
6. Air conditioner and heater .....	3-46		
7. Others .....	3-50	<b>8. OTHERS</b>	
		1. Central grease lubrication system .....	8-1
<b>4. OPERATION</b>		2. Quick coupler .....	8-6
1. Suggestion for new machine .....	4-1		
2. Check before starting the engine .....	4-2	<b>INDEX</b> .....	9-1
3. Starting and stop the engine .....	4-3		
4. Warming-up operation .....	4-8		
5. Operation of the working device .....	4-9		
6. Traveling of the machine .....	4-10		
7. Efficient working method .....	4-15		
8. Adjustment of the work equipment .....	4-22		

CLICK HERE TO **DOWNLOAD** THE COMPLETE MANUAL

- Thank you very much for reading the preview of the manual.
- You can download the complete manual from: [www.heydownloads.com](http://www.heydownloads.com) by clicking the link below



- Please note: If there is no response to CLICKING the link, please download this PDF first and then click on it.

CLICK HERE TO **DOWNLOAD** THE COMPLETE MANUAL

## 12) CONNECTOR (item 16)

This warning label is positioned on the side of the battery box.

### ⚠ Before carrying out any electric welding on this machine

- Pull the connectors out of all electronic control units.
- Connect the ground lead of the welding equipment as close to the welding point as possible.

※ Refer to the page 6-48 for details.

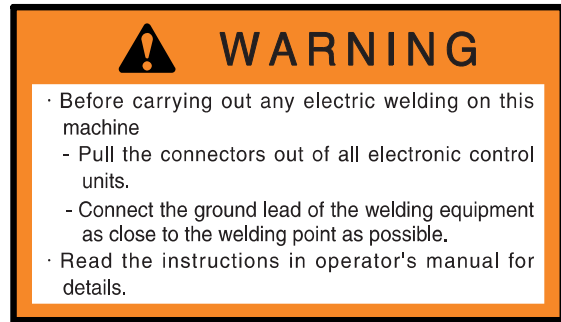

7803AFW20

## 13) LIFT & TIE (item 18)

This label is positioned on the both side of the front and rear frame.

### - Lifting point

In order to lift the machine, attach the lifting devices to the lifting points.

### - Tying point

In order to tie down the machine, attach the tie-downs to the tying points.

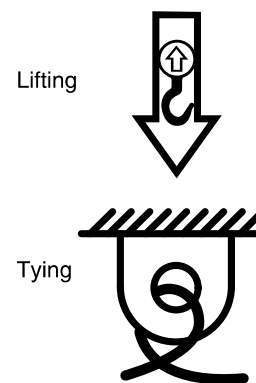

75790FW04

## 14) AIR CLEANER (item 19)

The warning label is positioned on the air cleaner.

- ### ⚠ Periodic and proper inspection, cleaning and change of elements prolong engine life time and maintain the good performance of engine.

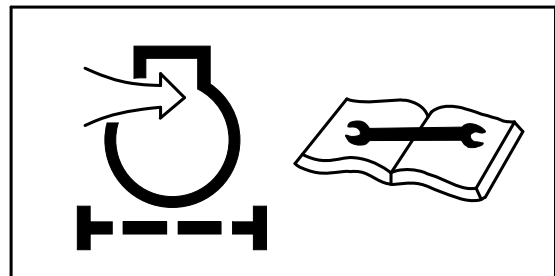

21070FW01

## 15) RADIATOR CAP (item 20)

This warning label is positioned on the radiator cover.

- ### ⚠ Never open the filler cap while engine running or at high coolant temperature.



77070FW11

## SECONDARY CAB EXIT

The door on the right side of the cab, also serves as a secondary exit.

Only in case of emergency, use installed the hammer for breaking the windshield of cab, and then exit carefully.

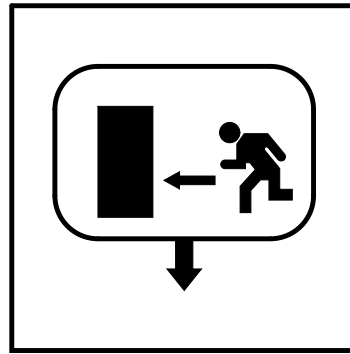

7707FW12

## FIRE EXTINGUISHER AND FIRST AID KIT

Be sure fire extinguishers have been provided and know how to use them.

Provide a first aid kit at the storage point.

Know what to do in the event of a fire.

Be sure you know the phone numbers of persons you should contact in case of an emergency.

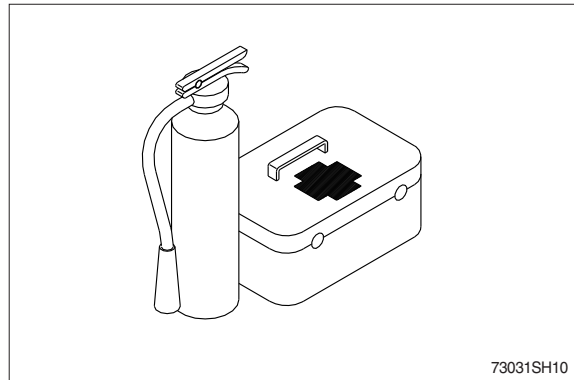

73031SH10

## UNAUTHORIZED MODIFICATION

Any modification made without authorization from Hyundai can create hazards.

Before making a modification, consult your Hyundai distributor. Hyundai will not be responsible for any injury or damage caused by any unauthorized modification.

## SEAT BELT

Check the condition of the seat belt and mounting hardware before operating the machine. If the seat belt mounting hardware is worn or damaged, replace the seat belt mounting hardware. Make sure that the mounting bolts are tight.

Replace the seat belt at least once every three years regardless of appearance.

Always use seat belts when operating your machine.

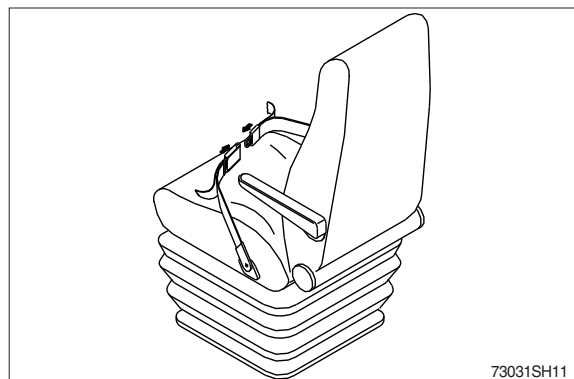

73031SH11

## MODIFICATIONS

Modifications to the machine, including use of unauthorized accessories and spare parts, may affect the machine's condition and its ability to function as it was designed. No changes of any kind may be performed without first obtaining written approval from Hyundai. Hyundai reserves the right to refuse all warranty claims that have resulted due to or can be attributed to unauthorized modifications.

Never modify the operator's cabin by welding, grinding, drilling holes or adding attachments unless instructed by Hyundai in writing. Changes to the cabin can cause loss of operator protection from roll-over and falling objects, and result in death or serious injury.

The person who performs unauthorized modifications assumes all responsibility for consequences that arise due to the modification or can be attributed to the modification, including damage to the machine.

Modifications may be considered to be officially approved, if at least one of the following conditions has been met :

1. The attachment, the accessory, or the spare part has been made or distributed by Hyundai and has been installed according to approved methods described in a publication available from Hyundai; or
2. The modification has been approved in writing by the Engineering Department at each product company within Hyundai.

### 3. DURING MAINTENANCE

During maintenance do not allow any unauthorized person to stand near the machine. Also, be careful of people in the vicinity.

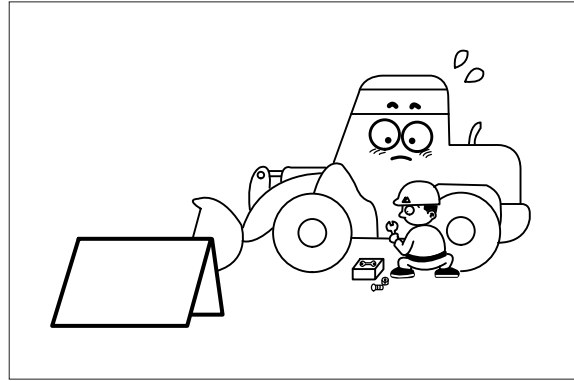

Stop the engine immediately when the trouble of the machine is found. Inspect immediately the cause of trouble such as vibration, overheating and trouble in the cluster then repair.

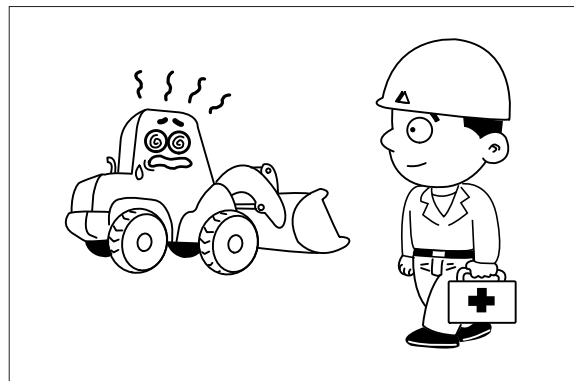

Park on a flat place for inspecting and repairing and properly TAG machine is not operational. (remove start key)  
Extreme care shall be taken during maintenance work.  
Parts may require additional safe guarding.

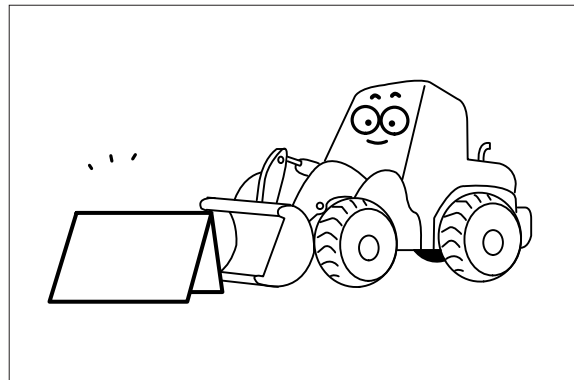

Do not remove the radiator cap from hot engine. Open the cap after the engine is cool, below 50°C (112°F) to prevent personal injury from heated coolant spray or steam.



73031SH46

### 3. WEIGHT

Item		kg	lb
Front frame assembly		2154	4750
Rear frame assembly		2417	5330
Front fender (LH & RH)		48	106
Counterweight		1200	2650
Additional counterweight (HL770XTD-9A)		520	1150
Cab assembly		1050	2320
Engine assembly		800	1760
Transmission assembly		760	1680
Drive shaft (front)		37	82
Drive shaft (center)		37	82
Drive shaft (rear)		21	46
Front axle (include differential)		1200	2650
Rear axle (include differential)		1090	2400
Tire (26.5-25 20PR, L3)		394	870
Hydraulic tank assembly		285	624
Fuel tank assembly		390	860
Main pump assembly		80	176
Fan & brake pump assembly		11.5	25.3
Main control valve (3 spool)		75	165
Flow amplifier		29	64
Boom assembly	HL770-9A	1610	3550
	HL770XTD-9A	1820	4010
Bell crank assembly		460	1010
Bucket link		73	160
4.2 m <sup>3</sup> bucket, with bolt on cutting edge		2160	4760
4.0 m <sup>3</sup> bucket, with tooth		2070	4560
Boom cylinder assembly		225	496
Bucket cylinder assembly		235	518
Steering cylinder assembly		44	97
Seat		40	88
Battery		55	121

**(13) Stop engine warning lamp**

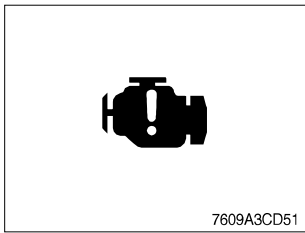

- ① If the lamp lights ON and the buzzer sounds, stop the engine immediately and check the engine.
- ② Check the fault codes on the monitor.
- ※ **Please contact your Hyundai service center or local dealer.**

**(14) DPF (Diesel particulate filter) warning lamp**

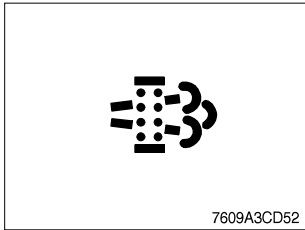

- ① This warning lamp lights ON or blinks when the regeneration is needed as table below.
- ※ **Consequences of delaying regeneration**
  - Poor performance caused by increasing exhaust gas pressure.
  - Higher fuel consumption
  - Shorter filter lifetime

Condition	Warning lamp				Remedy
	DPF		Check engine	Stop engine	
	Automatic regeneration (unfunction)	Automatic regeneration (function)			
Normal	Off	Off	Off	Off	· Automatic regeneration
Soot low	On	Off	Off	Off	· Automatic or manual regeneration · When automatic regeneration start function DPF lamp automatically switched off
Soot midium	Blink	Off	Off	Off	· Initiate a manual regeneration as following page (When automatic regeneration did not work) · Engine power may be reduced automatically (soot medium)
Soot high	Blink	Off	On	Off	· Automatic regeneration did not work · Initiate a manual regeneration · Engine power and speed will be reduced automatically
Stop	Off	Off	Off	On	· Stop the engine immediatary. · Please contact your Hyundai service center or local dealer.

\* Automatic regeneration start function depends on inside temperature of aftertreatment device.

**(1) Function of sub menu icons**

**1 Previous step button** (same as ESC function)

- Move to previous screen.
- Close pop up screen.

**2 Scroll**

- Display present page/total page.
- Move to page by using up / down arrow button.

**3 Move to main menu**

- Main menu icon is shown at the below of screen.
- You can choose the main menu directly.

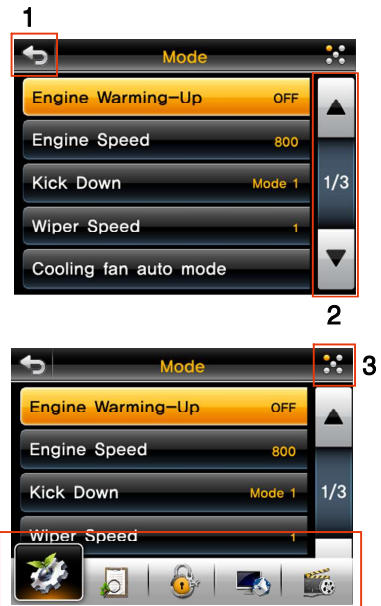

7609A3CD30/31

**(2) Mode**

**① Engine warming up**



- Setting engine warming-up ON/OFF

**② Engine speed**



- Setting engine low idle rpm

## ② Maintenance

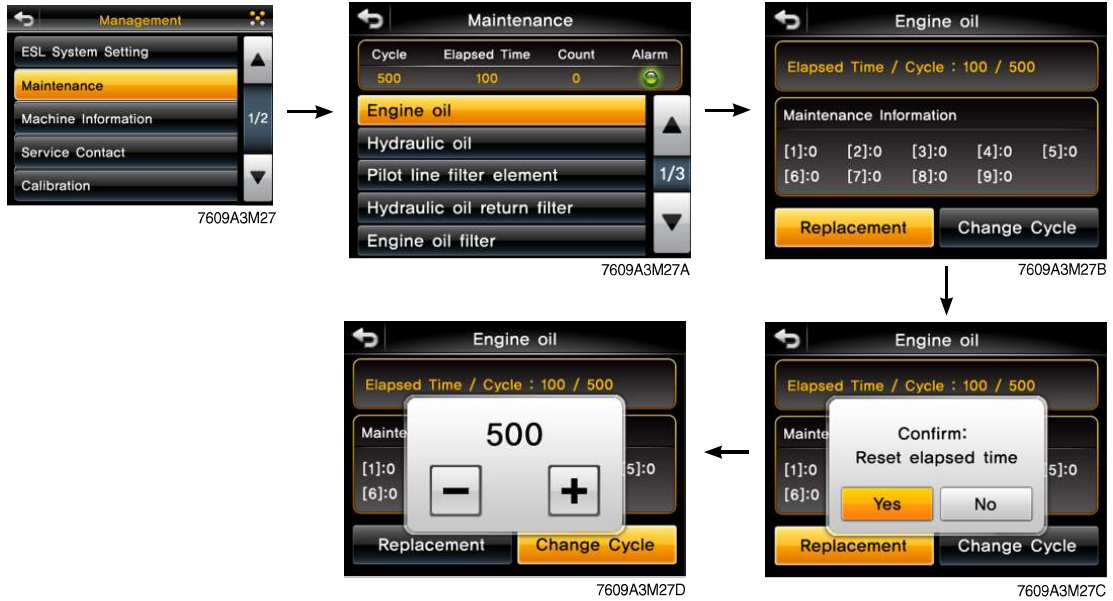

- Alarm : Warning
- Replacement : The elapsed time will be reset to zero.
- Change cycle : The change or replace cycle can be changed in the unit of 50 hours.
- To change cycle, press +/- button (◀ or ▶/OK).
- **Change or replace interval**

No	Item	Interval
1	Engine oil	500
2	Hydraulic oil	★ <sup>1</sup> 2000 ★ <sup>2</sup> 5000
3	Pilot line filter element	1000
4	Hydraulic oil return filter	1000
5	Engine oil filter	500
6	Fuel filter element	500
7	Fuel pre-filter	500
8	Hydraulic tank air breather	250
9	Radiator coolant	2000
10	Transmission oil and filter	1000
11	Axle oil (front and rear)	1500
12	Aircon & heater outer filter	1000
13	Air cleaner element (safety)	4000
14	Air cleaner element (primary)	4000
15	Crankcase ventilation filter	2000

★<sup>1</sup> : Conventional hydraulic oil

★<sup>2</sup> : Hyundai genuine long life hydraulic oil

## 12) RIDE CONTROL SWITCH (option)

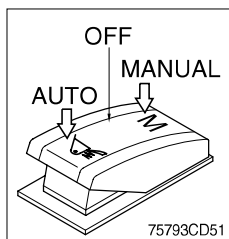

### (1) AUTO

Press in the bottom of the ride control switch in order to turn on the automatic ride control. The automatic ride control automatically turns on when the travel speed exceeds a preset speed of approximately 7 km/h. The automatic ride control automatically shuts off during low speed travel (below 7 km/h).

### (2) MANUAL

Press in the top of the ride control switch in order to turn on the system for ride control regardless speed. The ride control will smooth the ride of the machine during travel.

### (3) OFF

Press the ride control switch to the middle position in order to turn off the system for the ride control.

## 13) EMERGENCY TEST SWITCH (option)

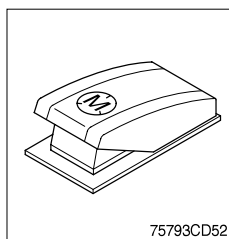

(1) The emergency steering system can be manually tested. Push the switch in order to determine if the emergency steering and the emergency steering lamp are functional.

(2) When the switch is pressed, the emergency steering pump motor will run. The emergency steering lamp will light. If the emergency steering lamp does not light, do not operate the machine.

## 14) ATTACHMENT LOCK SWITCH (option)

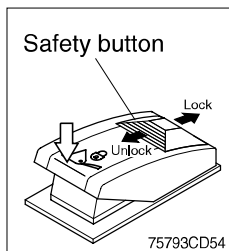

(1) Press this switch in order to engage the quick coupler pins.

(2) If this switch is pressed for 5 seconds, the quick coupler pins move in the engaged position. If the switch is released, the quick coupler pins will remain in the engaged position.

※ **This switch can be pressed only when the safety button is pulled to the unlock position.**

※ **Check for engagement as followings.**

- ① Put down pressure on the attachment.
- ② Back up the machine and make sure that there is no movement between the quick coupler and attachment.

### 1) POWER OFF SWITCH

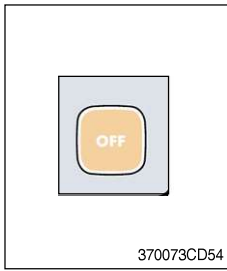

- (1) This switch makes the system and the LCD OFF.  
Just before the power OFF, set values are stored.

#### (2) Default setting values

Function	Air conditioner	In/outlet	LCD	Temperature	Mode
Value	OFF	Inlet	OFF	Previous sw OFF	Previous sw OFF

### 2) AUTO SWITCH

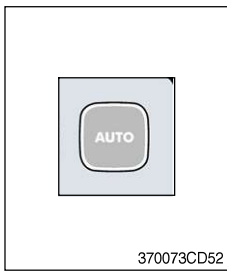

- (1) Turn the starting switch to ON position, LCD lights ON.  
Auto air conditioner and heater system automatically keeps the optimum condition in accordance with operator's temperature configuration sensing ambient and cabin inside temperature.

- (2) This switch can restart system after system OFF.

### 3) AIR CONDITIONER SWITCH (compressor switch)

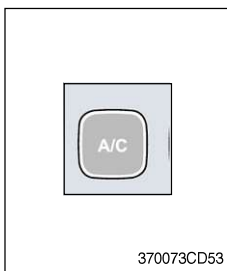

- (1) This switch turns the compressor and the LCD ON.
- (2) In accordance with the temperature sensed by duct (evaporator) sensor, compressor turns ON or OFF automatically.
- ※ **Air conditioner operates to remove vapor and drains water through a drain hose. Water can be sprayed into the cab in case that the drain cock at the ending point of drain hose has a problem.**

**In this case, exchange the drain cock.**

### 4) FAN SPEED SWITCH

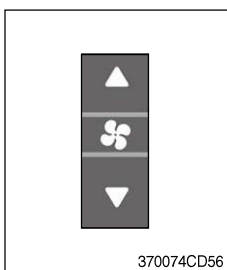

- (1) Fan speed is controlled automatically by set temperature.
- (2) This switch controls fan speed manually.
- There are 8 up/down steps to control fan speed.
  - The maximum step or the minimum step beeps 5 times.
- (3) This switch makes the system ON.

CLICK HERE TO **DOWNLOAD** THE COMPLETE MANUAL

- Thank you very much for reading the preview of the manual.
- You can download the complete manual from: [www.heydownloads.com](http://www.heydownloads.com) by clicking the link below



- Please note: If there is no response to CLICKING the link, please download this PDF first and then click on it.

CLICK HERE TO **DOWNLOAD** THE COMPLETE MANUAL

## 7) TRANSMISSION CONTROL UNIT (TCU)

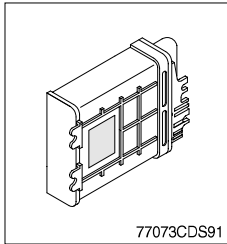

(1) The control unit is shifting the required speeds fully-automatically under consideration of the following criteria.

- Gear selector lever position
- Driving speed
- Load level

## 8) ENGINE CONTROL MODULE (ECM)

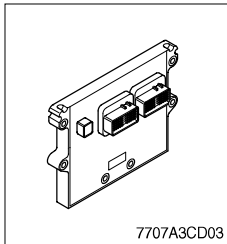

(1) The engine control module (ECM) is the control center of the engine system.

## 9) REAR CAMERA (option)

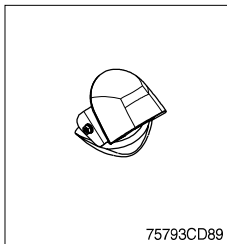

(1) The rear camera is available as a option.

※ Refer to page 3-32.

## 10) STEERING CONTROL UNIT (SCU, option)

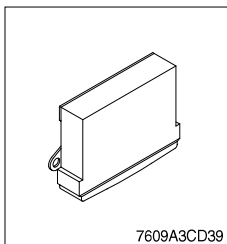

(1) The steering control unit (SCU) is the control center of the joystick steering system.

※ Refer to page 3-45.

### (9) Directory up

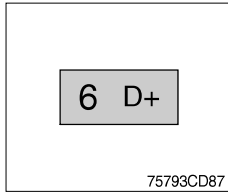

- ① Press D+ button briefly while playing MP3 . The next directory is located each time you press this button.
- ※ If the MP3 file does not have a directory, the unit play MP3 at 10-file intervals.
- ※ If any MP3 file does not exist in USB, this button can not operate.

## ■AUX PLAYER

### (1) Aux function

- **Use of USB socket** (machine serial No. : -#0113)

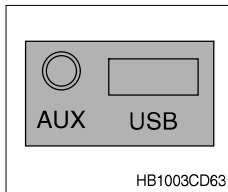

- ① If you want to listen to music of a external audio device, connect a external audio device into the USB port.
- ② Press mode button to change a current mode for AUX. If audio file of audio device is playing, you can listen to music through speaker.

- **Use of USB/AUX cable** (option)

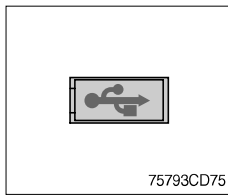

- ① If you want to listen to music of a external audio device, connect a external audio device through USB/AUX cable.
- ② Press mode button to change a current mode for AUX. If audio file of audio device is playing, you can listen to music through speaker.

## 2) STARTING ENGINE IN NORMAL TEMPERATURE

※ **Sound the horn to warn the surroundings after checking if personnel or obstacles are in the area.**

(1) Check if the parking brake is locked (with the parking switch ON).

(2) Check if the gear selector lever is in the neutral position.

(3) Check if the pilot cut off switch is locked (with the switch OFF)

(4) Turn the starting switch to START position to start the engine.

※ **Do not crank the engine for more than 20 seconds. If the engine does not start, allow the starter to cool for about 2 minutes before attempting to start the engine again.**

(5) Release the starting switch instantly after the engine starts to avoid possible damage to the starting motor.

※ **Refer to the START PROCEDURE on the page 0-12.**

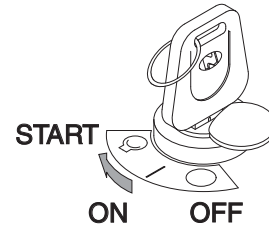

77074OP04

## 2) TRAVELING ON A SLOPE

- (1) Never travel down a slope in neutral.
  - (2) Lower the bucket 20-30 cm (1 ft) to the ground so that it can be used as a brake in an emergency.
  - (3) If the machine starts to slide or loses stability, lower the bucket immediately and brake the machine.
  - (4) When parking on a slope, use the bucket as a brake and place blocks behind the tires to prevent sliding.
- ※ **Machine cannot travel effectively on a slope when the oil temperature is low. Do the warming-up operation when it is going to travel on a slope.**
  - ※ **Be careful when working on slopes. It may cause the machine to lose its balance and turn over.**

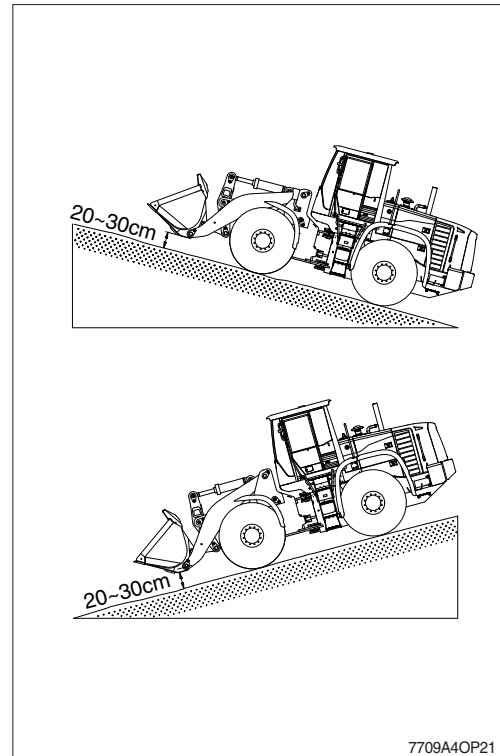

### **3) SEA SHORE OPERATION**

- (1) Prevent ingress of salt by securely tightening plugs, cocks and bolts of each part.
- (2) Wash machine after operation to remove salt residue.  
Pay special attention to electrical parts and hydraulic cylinders to prevent corrosion.
- (3) Inspection and lubrication must be carried out more frequently.  
Supply sufficient grease to replace all old grease in bearings which have been submerged in water for a long time.

## 6. TOWING THE MACHINE

- ▲ Personal injury or death could result when towing a disabled machine incorrectly.
- ▲ Block the machine to prevent movement before releasing the brakes. The machine can roll free if it is not blocked.

Except for an emergency, do not tow this machine. If it is inevitable to tow this machine, observe the following.

### 1) GENERAL

- (1) Parking brake cylinder of the machine is operated by the spring force and released by hydraulic pressure. If the engine does not operate, the brake will be operated to stop the machine.

- (2) When the machine is towed move it for a repair to nearby place at the speed less than 2 km/hr (1.2 mph). Transport it on a trailer, if it has to be moved for a long distance.

- (3) When the steering device and the brake of the machine to be towed can not be operated, transport by trailer.

▲ Be careful when towing.

▲ Be careful that the brake will not work if there is any disorder in the braking system.

- (4) When you tow the machine from the front, attach the tow line to the tow eyes on the front frame (1).

When you tow the machine from the rear, use the tow rear eyes provided for lift & tie (2).

- (5) Do not use a chain for pulling a disabled machine. A chain link can break. This may cause personal injury. Use a wire rope cable with ends that have loops or rings. Place an observer in a safe position in order to watch the pulling procedure. The observer can stop the procedure, if necessary. The procedure should be stopped if the cable starts to break. Also, stop the procedure if the cable starts to unravel. Stop pulling whenever the towing machine moves without moving the towed machine.

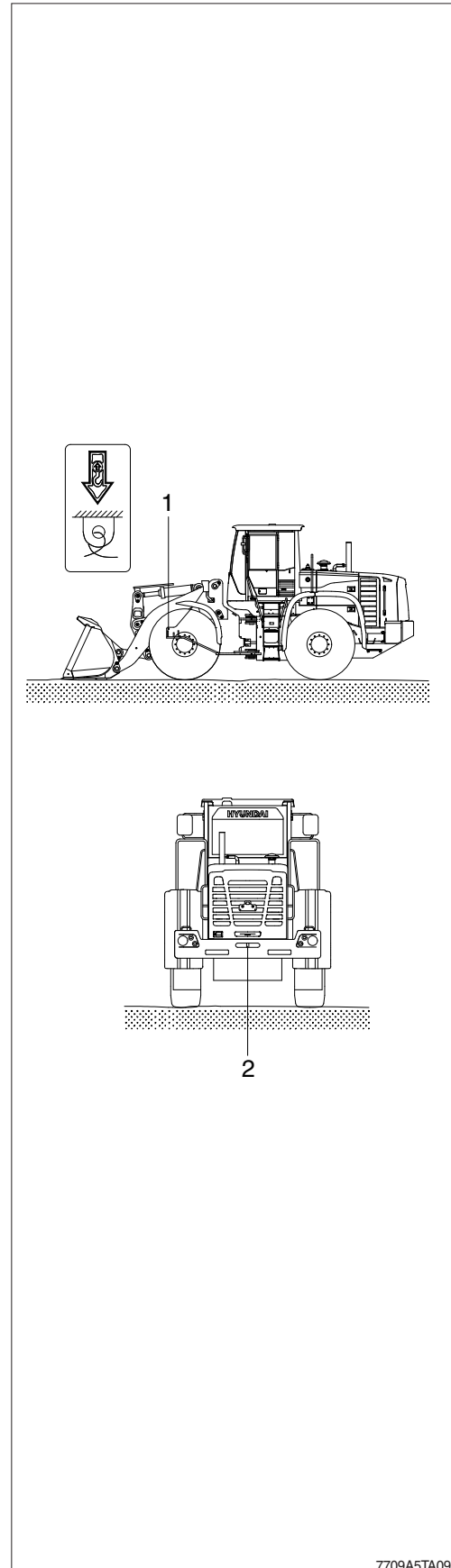

7709A5TA09

### 3. SPECIFICATION OF FUEL, COOLANT AND LUBRICANTS

#### 1) NEW MACHINE

New machine used and filled with following lubricants.

Description	Specification
Engine oil	SAE 15W-40 (API CJ-4)
Hydraulic oil	Hyundai genuine long life hydraulic oil (ISO VG46, VG68 only) Conventional hydraulic oil (ISO VG15)
Transmission oil	SAE 15W-40
Axle oil	*Refer to below list
Grease	Lithium base grease NLGI No. 2
Fuel	ASTM D975-No. 2, * <sup>1</sup> Ultra low sulfur diesel
Coolant (DCA4)	ASTM D6210 Mixture of 50% ethylene glycol base antifreeze and 50% water

**SAE** : Society of Automotive Engineers

**API** : American Petroleum Institute

**ISO** : International Organization for Standardization

**NLGI** : National Lubricating Grease Institute

**ASTM** : American Society of Testing and Material

**DCA4** : Brand name of Chemical Additive

manufactured by the Cummins Fleetguard Co

\* Recommended oil list

- BP TERRAC SUPER TRANSMISSION 10W-30

- CASTROL AGRI TRANS PLUS 10W-30

- MOBILFLUID 426

- SHELL DONAX TD 10W-30

- TOTAL DYNATRANS MPV

\*<sup>1</sup> Ultra low sulfur diesel

- sulfur content ≤ 15 ppm

#### 4) FLUSHING AND REFILLING OF RADIATOR

##### (1) Change coolant

- ▲ Avoid prolonged and repeated skin contact with used antifreeze. Such prolonged repeated contact can cause skin disorders or other bodily injury.

Avoid excessive contact-wash thoroughly after contact.

Keep out of reach of children.

- ▲ Protect the environment : Handling and disposal of used antifreeze can be subject to federal, state, and local law regulation.

Use authorized waste disposal facilities, including civic amenity sites and garages providing authorized facilities for the receipt of used antifreeze.

If in doubt, contact your local authorities for guidance as to proper handling of used antifreeze.

- ▲ Wait until the temperature is below 50°C (120°F) before removing the coolant system cap. Failure to do so can cause personal injury from heated coolant spray.

Drain the cooling system by turning the stopper to the open position.

A drain pan with a capacity of 57 liters (15 U.S.gallons) will be adequate in most applications.

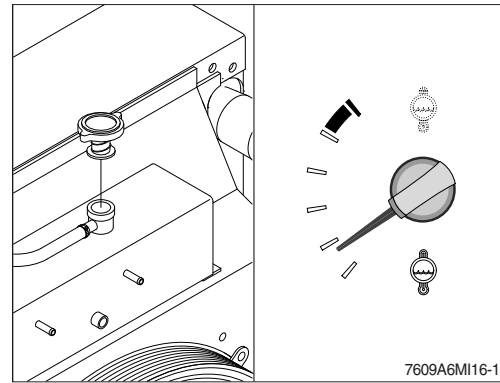

##### (2) Flushing of cooling system

- ① Fill the system with a mixture of sodium carbonate and water (or a commercially available equivalent).

- ※ Use 0.5 kg (1.0 pound) of sodium carbonate for every 23 liters (6.0 U.S. gallons) of water.

- ※ Do not install the cap. The engine is to be operated without the cap for this process.

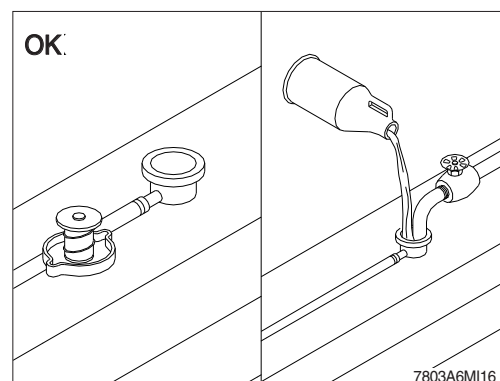
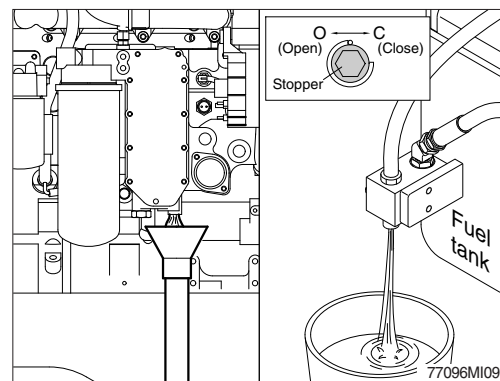

## (6) PRIME

**▲ Do not open the high-pressure fuel system with the engine running. Engine operation causes high fuel pressure. High-pressure fuel spray can cause serious injury or death.**

- ① Cycle the starting switch and allow the lift pump to run. The lift pump will run for 30 seconds. Afterwards, turn the starting switch off and back on again allowing the lift pump to run again.
- ② Allow the lift pump to run for three or four 30-second cycles before attempting to start the engine.

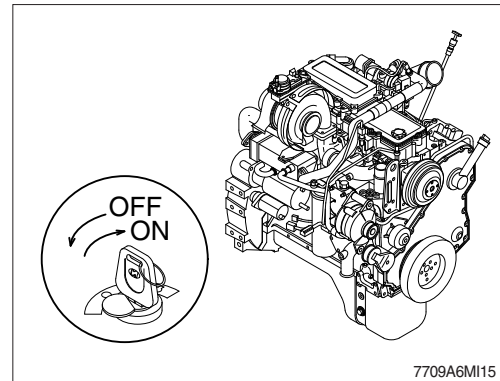

## (7) FINISHING STEPS

- ① Operate the fuel lift pump to help prime the fuel system. Turn the starting switch to ON, but do not attempt to start the engine. This will cause the ECM to operate the fuel lift pump through a priming cycle which lasts at least 30 seconds. Cycle the lift pump several times by keying off, waiting 10 seconds and keying back on again.
- ② Once the engine is started, slowly increase the engine speed while air is purged from the fuel plumbing.

## 13) FUEL WATER SEPARATOR

**▲ Water can contain toxic and carcinogenic material.**

**▲ Drain the water/fuel into a container and dispose of in accordance with local environmental regulations.**

- (1) Drain the water and sediment from the separator daily.
- (2) Shut off the engine.
- (3) Use your hand to open the drain valve.
- (4) Open the drain valve until fluid drains out of the drain tube.
- (5) Drain the filter sump until clear fuel is visible.

**※ Drain the water when the warning lamp blinks and fault code 418 on the cluster.**

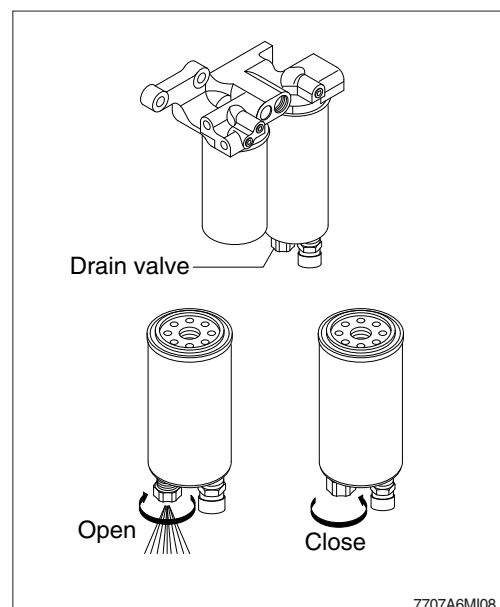

### (3) Direction of tire to be installed

- ① Be careful that the valve should be facing the outside.

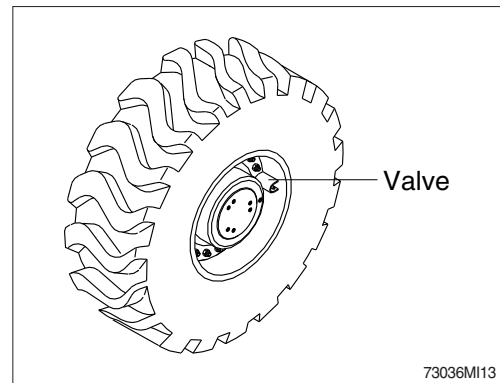

### (4) Mounting of tire

- ① Lightly tighten nuts as shown in the illustration.
- ② Lower the jack after tire is replaced.
- ③ Tighten nuts according to the specified tighten torque.
  - Tightening torque :  $79 \pm 2.5 \text{ kgf} \cdot \text{m}$   
( $571 \pm 18 \text{ lbf} \cdot \text{ft}$ )

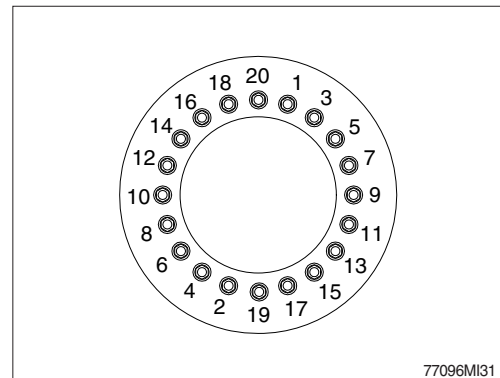

### 26) STORING TIRES AFTER REMOVAL

As a basic rule, store the tires in a warehouse which unauthorized persons cannot enter. If the tire are stored outside, always erect a fence around the tires and put up "No Entry" and other warning signs that even young children can understand.

Stand the tire on level ground, and block it securely so that it cannot roll or fall over.

If the tire should fall over, get out of the way quickly. The tires for construction equipment are extremely heavy, so trying to hold the tire may lead to serious injury.

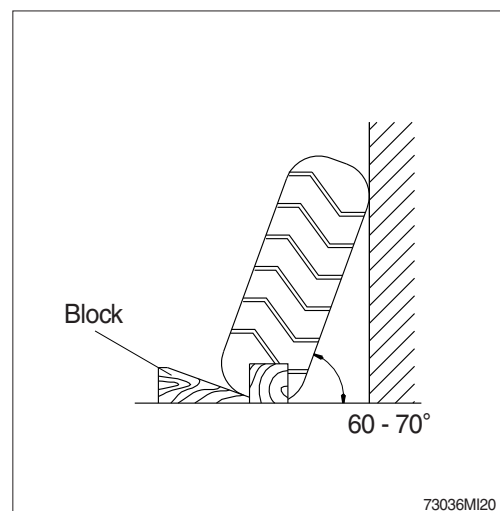

## 7. ELECTRICAL SYSTEM

### 1) WIRING, GAUGES

Check regularly and repair loose or malfunctioning gauges when found.

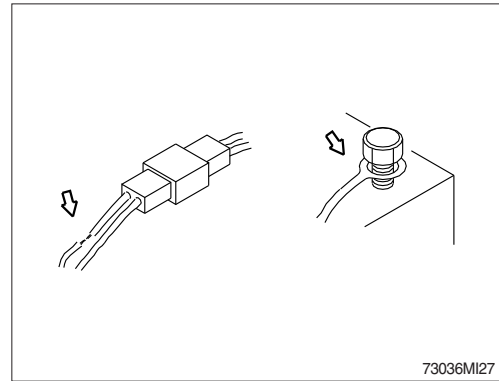

### 2) BATTERY

#### (1) Clean

- ① Wash the terminal with hot water if it is contaminated, and apply grease to the terminals after washing.
- ▲ **Battery gas can explode. Keep sparks and flames away from batteries.**
  - ▲ **Always wear protective glasses when working with batteries.**
  - ▲ **Do not stain clothes or skin with electrolyte as it is acid.**  
Be careful not to get the electrolyte in eyes.  
Wash with clean water and go to the doctor if it enters the eyes.
  - ▲ **Avoid short-circuiting the battery terminals through accidental contact with metallic objects, such as tools, across the terminals.**
  - ▲ **Do not store tools, bucket tooth and other flammable things in battery box. They could cause a fire.**
  - ▲ **Tighten the battery terminals securely.**  
Loosened terminals can generate sparks and lead to explosion.
  - ▲ **Make sure that the battery terminal's caps always are installed.**

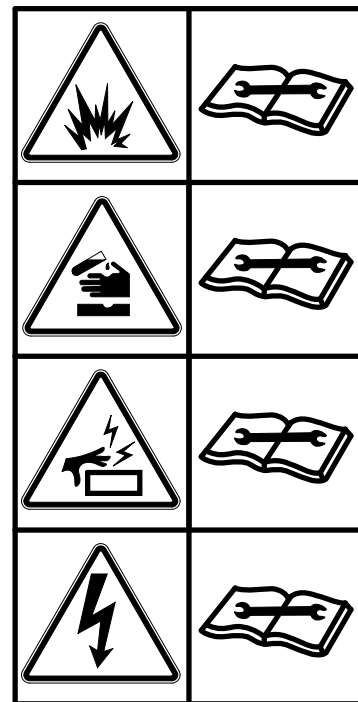

7579A0FW30

CLICK HERE TO **DOWNLOAD** THE COMPLETE MANUAL

- Thank you very much for reading the preview of the manual.
- You can download the complete manual from: [www.heydownloads.com](http://www.heydownloads.com) by clicking the link below



- Please note: If there is no response to CLICKING the link, please download this PDF first and then click on it.

CLICK HERE TO **DOWNLOAD** THE COMPLETE MANUAL