

TO THE OWNER OF CASE POCLAIN EXCAVATOR

Use this manual as your guide. Your machine will remain a reliable tool as long as you follow the servicing and operating instructions.

Your CASE POCLAIN dealer will remain at your disposal for after-sales service if required and for supply of genuine CASE POCLAIN parts: your guarantee of quality and match.

If you require any further information, contact your CASE POCLAIN dealer.

TRACK EXCAVATOR MODEL 1088CS - 1088 maxi

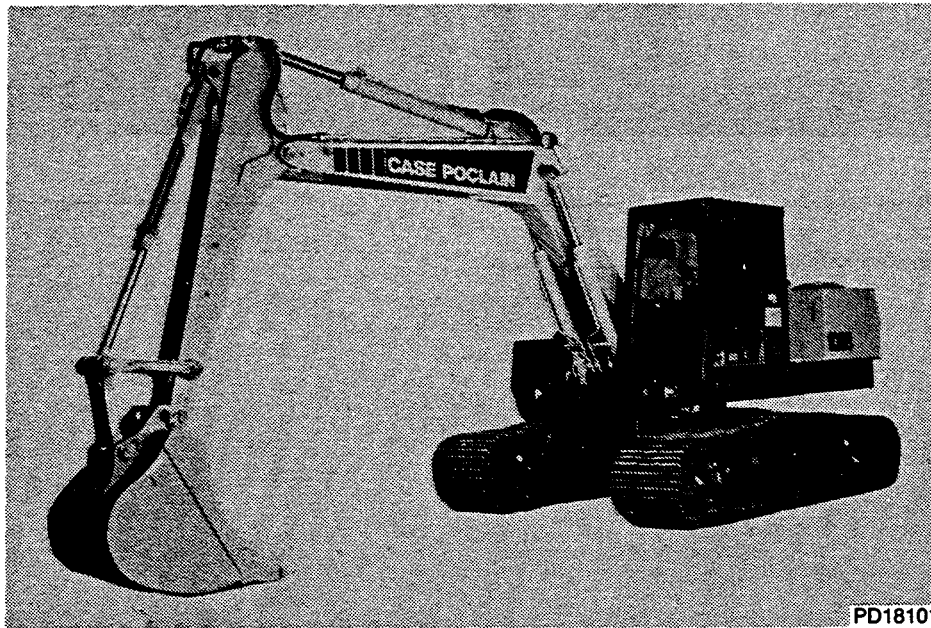

CLICK HERE TO **DOWNLOAD** THE COMPLETE MANUAL

- Thank you very much for reading the preview of the manual.
- You can download the complete manual from: www.heydownloads.com by clicking the link below



- Please note: If there is no response to CLICKING the link, please download this PDF first and then click on it.

CLICK HERE TO **DOWNLOAD** THE COMPLETE MANUAL

SAFETY/DECALS/HAND SIGNALS

DECALS

IMPORTANT : Place new decals if the old ones are destroyed, lost, painted over or if they are no longer legible. When replacing a part which has a decal, make sure to put a new decal on each new part.

NOTE : You can obtain new decals from your CASE POCLAIN dealer; the Part Numbers are shown at the base of each decal.

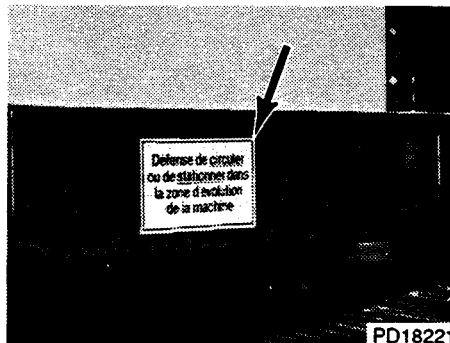
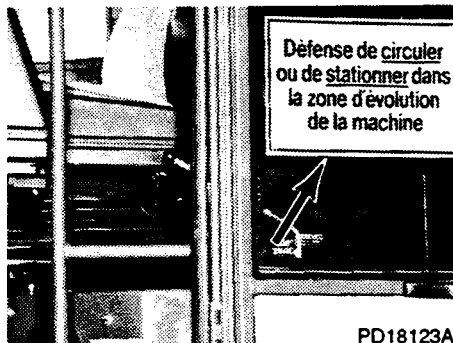

Keep Clear decals are located on the right and left-hand sides of the machine.

Code number of decal depending on country:

France.....	K1451562	Sweden.....	D1451556
Great Britain.....	H1451560	Holland.....	E1451557
Germany.....	J1451561	Finland.....	C1451555
Spain.....	F1451558	Norway.....	S1751581
Italy.....	G1451559	Switzerland.....	J1451561
Portugal.....	H1451560	Austria.....	J1451561

Slinging points

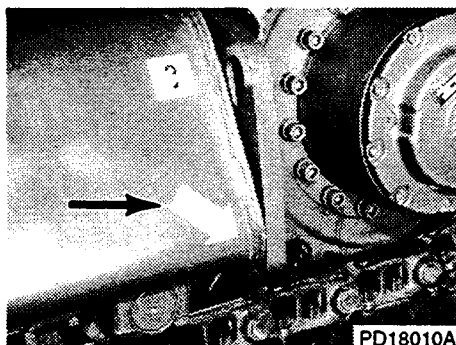

This decal shows the slinging points on the lower chassis for use when lifting the machine.

Decal Part Number : H7947565

SECTIONAL INDEX

Attachments.....	26
Buckets.....	28
Ditch-cleaning with smooth or notched reversible blade.....	28
Ditch-cleaning with teeth.....	28
Earth-moving.....	28
Trench, with ejector.....	28
V-type.....	28
Clamshells.....	29
Beet.....	29
Boring.....	29
Earth-moving.....	29
Handling.....	29
Trench, with ejector.....	29
5-tine grabs for scrap.....	29
5-tine grabs for stone, with detachable teeth.....	29
Electrical system.....	23
Engine.....	22
Working specifications.....	22
Ground pressure.....	26
Hydraulic system.....	23
Instrument gauges.....	25
Lifting the machine.....	40
Overall dimensions of machine.....	30-31
Safety features.....	25
Transport overall dimensions.....	32-33
with Backhoe bucket.....	32-33
with Clamshell.....	33
Travel.....	26
Undercarriage.....	25
Upperstructure.....	24
Cab.....	24
Operation.....	24
Swing.....	24
Welded frame.....	24
Warning lamps.....	25
Weights.....	27
Cab.....	27
Counterweight.....	27
Attachments.....	27
Machine.....	27
Working ranges.....	34-39
with backhoe bucket.....	34-37
with clamshell.....	38-39

SPECIFICATIONS

	1088CS	1088 maxi
A (0.50 m pads)	2.47 m.....	2.87 m
A (0.60 m pads)	2.57 m.....	2.97 m
A (0.70 m pads)	2.67 m.....	
A (0.75 m pads)		3.12 m
A (0.90 m pads)		3.27 m
B.....	1.97 m.....	2.37 m
C.....	2.61 m.....	3.00 m
D.....	2.40 m.....	2.40 m
E.....	3.05 m.....	3.05 m
F.....	0.50 m.....	0.50 m
G.....	2.44 m.....	2.44 m
H.....	3.25 m.....	3.59 m
I.....	4.05 m.....	4.41 m
J.....	4.70 m.....	4.87 m
K.....	0.94 m.....	0.98 m
L.....	1.15 m.....	1.15 m
M.....	2.67 m.....	2.67 m

NOTE : *0.70 m track pads are not fitted to the 1088 maxi. 0.90 m track pads are not fitted to the 1088CS and 0.75 m track pads are fitted only to the 1088 maxi.*

SECTIONAL INDEX

Battery master switch.....	56	Heating system.....	55
Bucket or clamshell		Air distributor.....	55
selection valve.....	58	Heater control knob.....	55
Cab door.....	42	Recirculation inlet.....	55
Driving position controls.....	48-54	Windshield defrosting air	
Ashtray.....	51	distributor.....	55
Attachment and swing		Hydraulic tank shutoff valve.....	56
control levers.....	48	Instrument panel.....	44-47
Cigarette lighter.....	51	Air filter warning lamp.....	44
Coat-hook.....	51	Battery charge warning lamp.....	44
Cold weather start button.....	53	Engine oil pressure warning lamp...44	
Control cancellation arm-rest.....	52	Engine temperature gauge.....	44
Driver's seat.....	52	Fuel gauge.....	44
Driving position lighting.....	51	Hydraulic filters warning lamp.....	45
Electrical power line connection.....	51	Pilot pressure warning lamp.....	45
Emergency pump.....	50	Rotary lamp indicator lamp.....	45
Engine accelerator lever.....	49	Rotary lamp switch.....	47
Fan.....	53	Ventilation blower switch.....	46
Fire extinguisher.....	53	Warning light check switch.....	47
Horn button.....	49	Windshield wiper switch.....	46
Hourmeter.....	50	Working lamp indicator Lamp.....	45
Option pedal.....	48	Working lamp Switch.....	46
Overload indicator.....	54	Steps and access handles.....	43
Protection bar.....	54	Tool box.....	56
Quick-hitch bucket control.....	53	Windshield wiper.....	58
Radio location.....	51		
Starter switch.....	49		
Sun-visor.....	50		
Travel control pedals.....	48		
Upperstructure locking handle.....	50		
Electrical power line			
connections.....	57		
Valve bank partition.....	57		
Walkway.....	57		
Front and rear-view mirrors.....	58		

Electrical power line connection

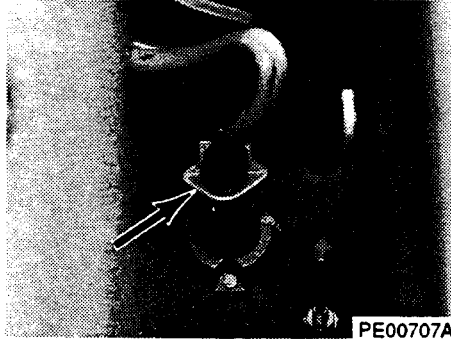

This connection provides power for the cab electrical equipment.

Location for cab radio

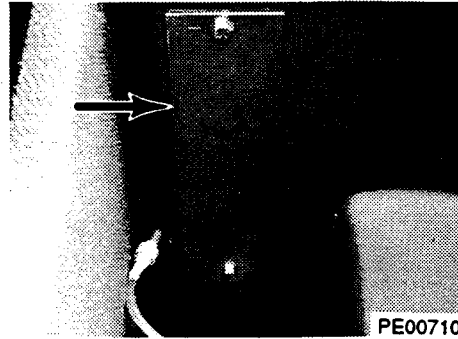

This location is provided for fitting a 12 V car radio.

Coat-hook

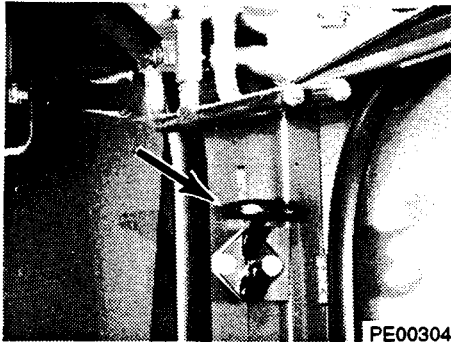

Dome lamp

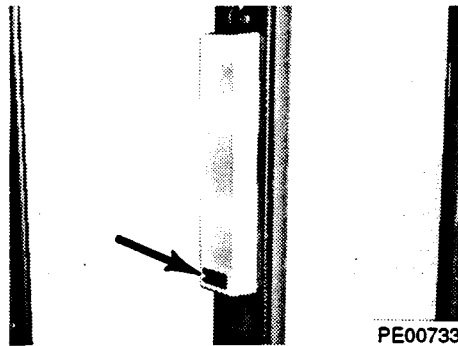

The lamp is controlled by a switch incorporated in the lamp base.

Cigarette-lighter

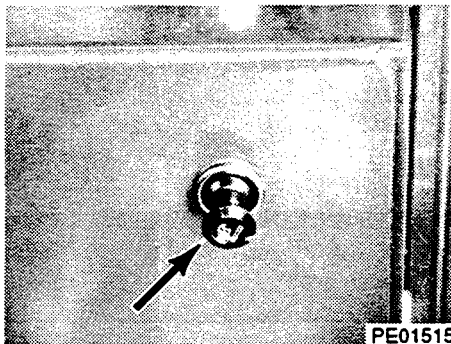

The cigarette-lighter is located at the rear left hand of the cab.

Ashtray

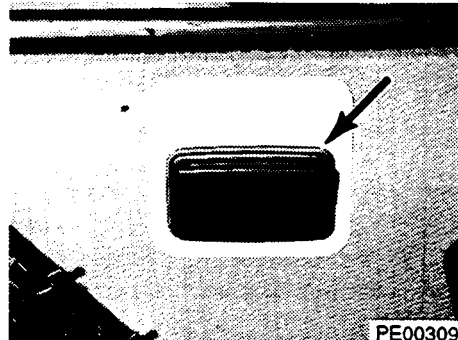

OPERATOR'S SEAT

NOTE : *The seat can only be adjusted correctly when the operator is sitting on the seat.*

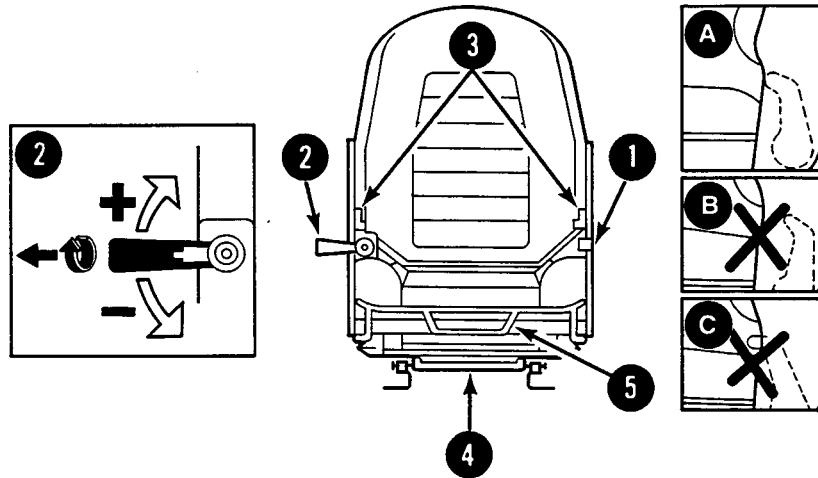

PDE0019

Suspension adjustment according to operator's weight

To check and set the correct suspension for the seat, proceed as follows:

1. Sit in the seat.
2. Check the tension indicator (1).

Figure A shows the correct tension. The indicator is on a level with the seat back frame.

Figure B The indicator shows that the tension is insufficient. Increase the tension.

Figure C the indicator shows that the tension is too high. Decrease the tension.

3. To increase the tension, use the tension adjustment lever (2). Pull the handle and turn it until the + (plus) sign is on top, then release the lever (2). Move the lever (2) up and down until the tension indicator (1) shows the correct tension (Figure A).

4. To decrease the tension, use the tension adjustment lever (2). Pull the handle and turn it until the - (minus) is on top, then release the lever (2). Move the lever (2) up and down until the tension indicator (1) shows the correct tension (Figure A).

OPERATING INSTRUCTIONS

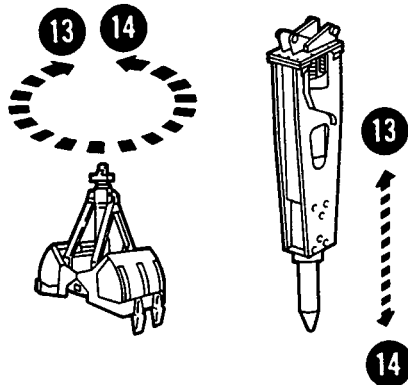
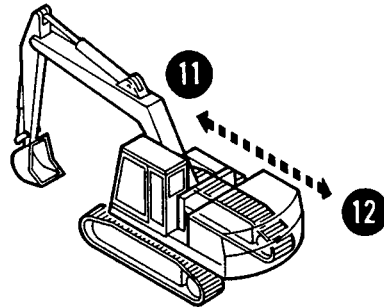
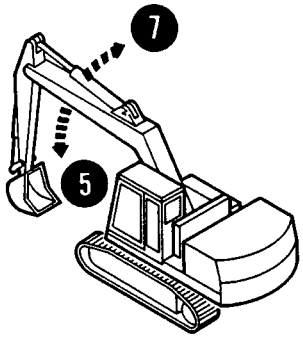
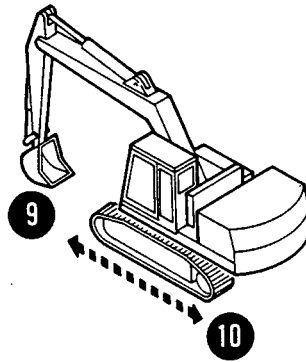
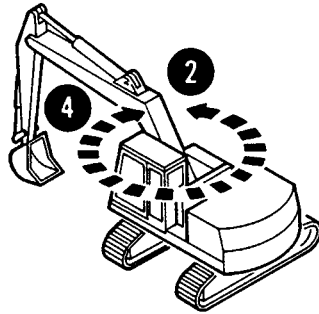
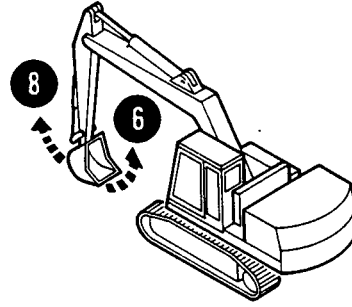
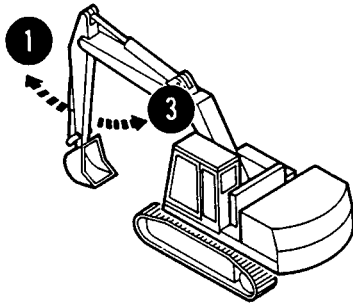

PDE0021

CLICK HERE TO **DOWNLOAD** THE COMPLETE MANUAL

- Thank you very much for reading the preview of the manual.
- You can download the complete manual from: www.heydownloads.com by clicking the link below



- Please note: If there is no response to CLICKING the link, please download this PDF first and then click on it.

CLICK HERE TO **DOWNLOAD** THE COMPLETE MANUAL

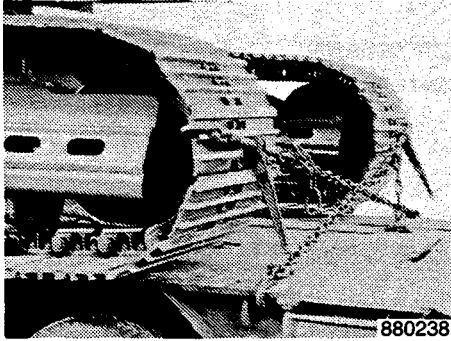

11. Use chains to fasten the dipper, the bucket and the machine to the trailer bed.

Unloading

1. Remove the blocks and the attaching chains.
2. Turn on the electricity by means of the battery master switch.
3. Disengage the upperstructure locking pin.
4. Raise the attachment so that the bucket (dipper or boom) is a few centimetres above the floor of the trailer.
5. Drive forward slowly, keeping the attachments always a few centimetres above the ground.

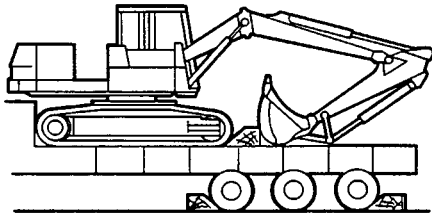

PDE0026

MACHINE READY FOR TRANSPORT

12. Measure the distance from the ground to the highest point of the machine. You must know the total height. See "Transport" in the "Specifications" section.

JOB SITE OPERATION

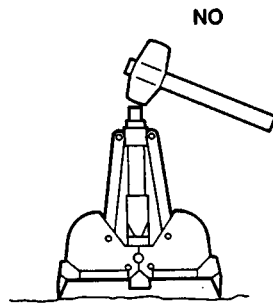

PDE0044

The clamshell is not a hydraulic hammer. Do not strike the ground to make it enter. Use the combined force of the cylinders for efficient digging.

When working in sticky soil, do not close the clam completely. It will then be easier to dump. Whenever possible, use trench type clamshells with ejectors.

To swing the clamshell, close it a little (2 to 3 cm only) so as to unlock it. Rest the teeth on the ground, retract the dipper whilst raising the boom, give the clamshell an impulse to make it swing, raise it and open it in the desired position so as to lock it.

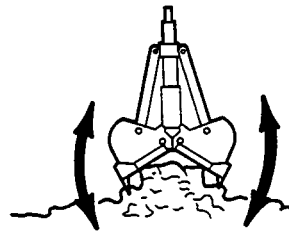

PDE0045

In hard ground, digging is easier if the shells are moved in and out over a short distance, while maintaining the pressure on the ground. It also makes it easier to fill the clam to the maximum.

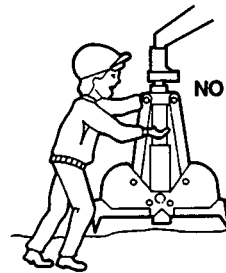

PDE0047

Never let someone guide the clamshell by hand. There is a risk of fingers being severed.

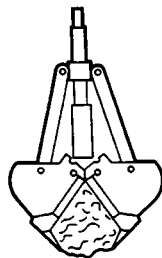

PDE0046

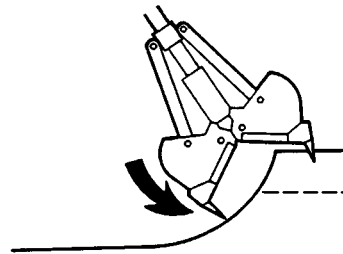

PDE0048

When using the clamshell for earthmoving, position the clamshell so that the larger number of teeth are on the outer side of the excavation and the smaller number towards the next place to be excavated.

With Long-mount

Removal

STEP 1

Place the clamshell open on flat, hard ground.

STEP 2

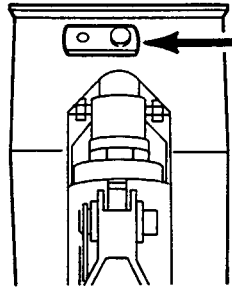

PDE0059

Move the attachment control levers in such a way that the pin is not gripped by the weight of the long-mount.

STEP 3

Stop the engine.

STEP 4

Decompress the clamshell cylinder circuit by means of the emergency pump.

See "Decompression of the Hydraulic Circuit" in the "Maintenance/Adjustments" section.

STEP 5

Disconnect the feed lines for the clamshell.

STEP 6

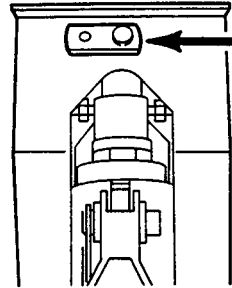

PDE0059

Remove the pin. see "Attachment Pins".

STEP 7

Start the engine.

STEP 8

Lift the attachment so as to free the long-mount.

Installation

STEP 1

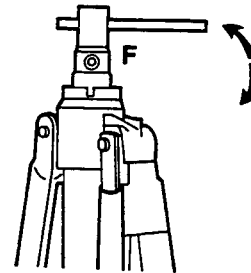

PDE0056

Turn the clamshell so that the letter (F) stamped on the cylinder rod is towards the cab.

STEP 2

Move the attachment control levers to move the long-mount into its housing.

SECTIONAL INDEX

Access panels.....	116	Fuel circuit.....	134-136
Air filter.....	137-141	Bleeding and priming	
Air filter cartridge refitting.....	140-141	the fuel circuit.....	135-136
Air filter cartridge removal.....	138-139	Bleeding the fuel tank	
Air filter cartridges.....	137	and fuel sediment filter.....	136
Air filter dust ejector.....	139	Fuel filter replacement.....	134-135
Air filter inspection.....	137	Grease points.....	118-121
Air filter service specifications.....	138	Slew ring and attachment.....	120-121
Air filtration restriction		Various tools.....	118-119
warning lamp.....	137	Hourmeter.....	113
Cleaning the primary		Hydraulic system.....	142-146
air filter cartridge.....	139-140	Anti-surge valve	
Primary air filter		filter replacement.....	146
cartridge inspection.....	140	Breather cap replacement.....	142
Cooling system.....	128-133	Hydraulic fluid change.....	144-146
Bleeding the		Hydraulic fluid reservoir level.....	142
cooling system.....	132-133	Hydraulic reservoir	
Coolant level.....	128	filter replacement.....	143-144
Coolant solutions.....	129	Hydraulic system	
Cooling system		service specifications.....	142
service specifications.....	128	Service intervals.....	114-115
Draining the cooling system.....	129	Swing reduction gear.....	147
Filling the cooling system.....	130-131	Swing reduction gear	
Engine hoods.....	117	oil change.....	147
Side panel.....	117	Swing reduction gear oil level.....	147
Upper hood.....	117	Swing reduction gear	
Engine.....	124-127	service specifications.....	147
Engine lubrication.....	124	Travel reduction gear.....	148
Engine oil change.....	125-126	Travel reduction gear oil change..	148
Engine oil filter replacement.....	127	Travel reduction gear oil level.....	148
Engine oil level.....	125	Travel reduction gear	
Engine service specifications.....	125	service specifications.....	148
Oil viscosity range.....	124		
Fluid levels.....	122-123		
Fluids and lubricants.....	112		
Anti-freeze/corrosion liquid.....	112		
Grease.....	112		
Hydraulic fluid.....	112		
Transmission component oil.....	112		

LUBRICATION/FILTERS/FLUIDS _____

I T E M S	S E R V I C E P O I N T S	N B O F P O I N T S	I N T E R V A L S I N H O U R S				
			C L E A N	R E P L A C E	C H E C K	G R E A S E	C H A N G E
1	Cooling circuit	1			10		
2	Engine oil	1			10		
3	Hydraulic reservoir	1			10		
4	Travel reduction gear	2			250		
5	Swing reduction gear	1			100		

LUBRICATION/FILTERS/FLUIDS

NOTE : Check the radiator cap fits tightly against the seal bearing surface.

STEP 8

Start the engine.

STEP 9

Warm up the engine by slowly accelerating, until the thermostat opening range is reached. The thermostat begins to open at 82°C (190°F) and is fully open at 94°C (214°F).

IMPORTANT : Do not remove the radiator cap while the engine is hot, as the cooling system will be under pressure.

STEP 10

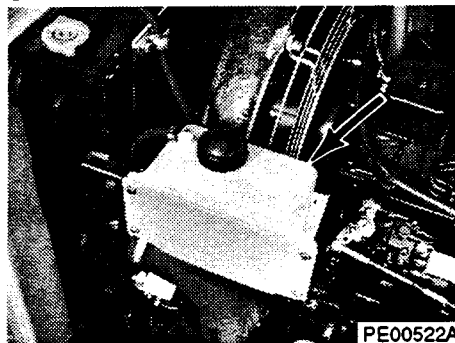

After half an hour, check the coolant level in the reservoir and make sure it is approximately 1 cm above the Maxi mark.

STEP 11

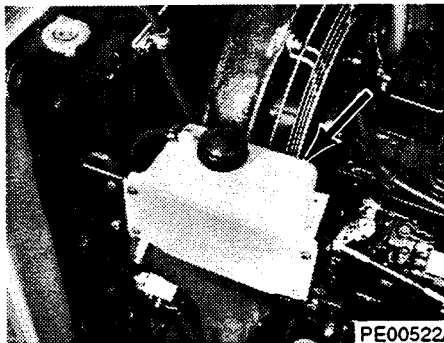

Once the engine is cold, check that the reservoir coolant level has dropped to the Maxi mark.

STEP 12

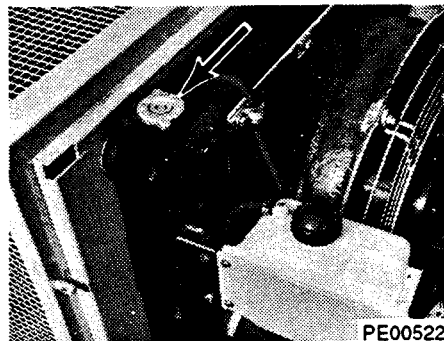

Remove the radiator cap. The coolant level should come up to the base of the filling neck. If this is not the case, top up the radiator and the coolant reservoir, then bleed the cooling system once more.

Reservoir filter replacement

STEP 1

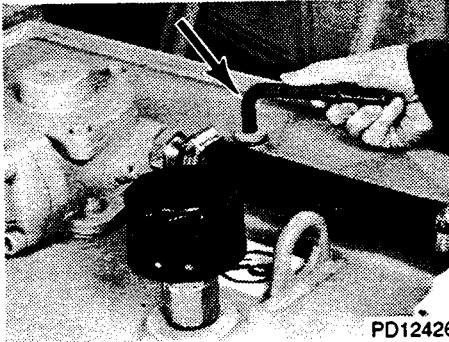

Loosen the reservoir bleed screw two or three turns to release pressure in the reservoir. Then re-tighten.

STEP 2

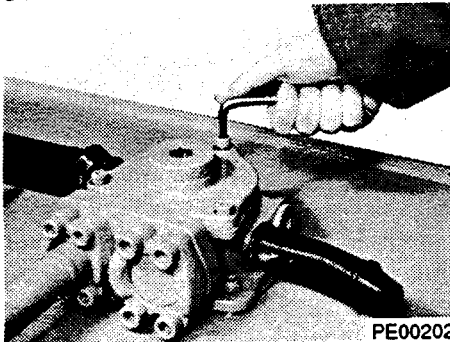

Remove the three screws and the cover.

STEP 3

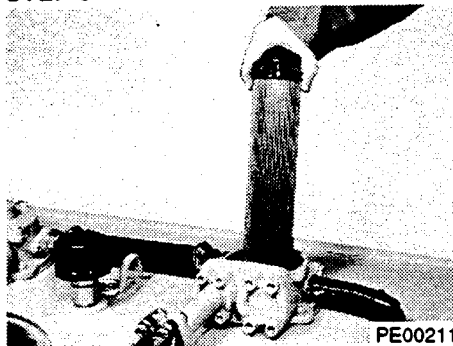

Remove the filter.

STEP 4

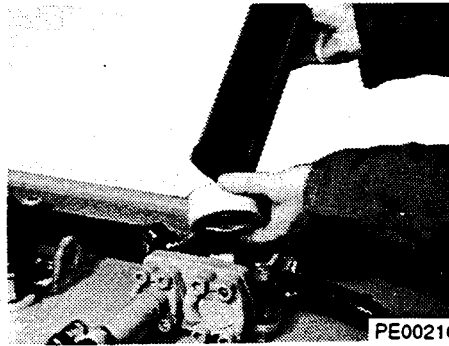

Remove the bowl and clean it.

STEP 5

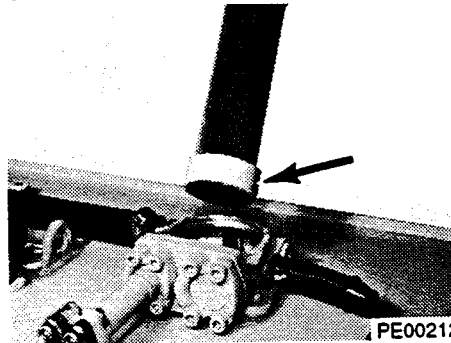

Put the bowl back on a new seal.

STEP 6

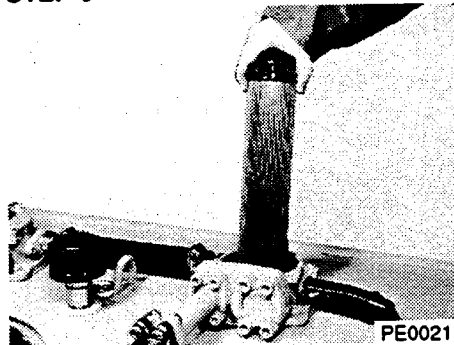

Install the new filter.

ENGINE FAN BELT

Daily, or every 10 hours of operation.
Visually check the condition of the belt.

Every 1000 hours.

STEP 1

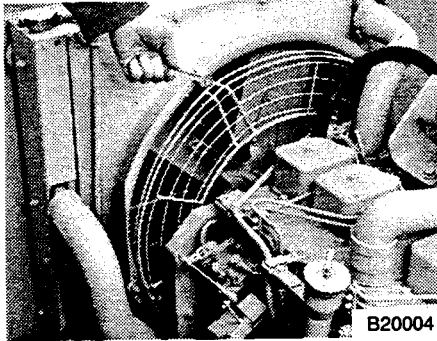

Remove the fan guard.

STEP 2

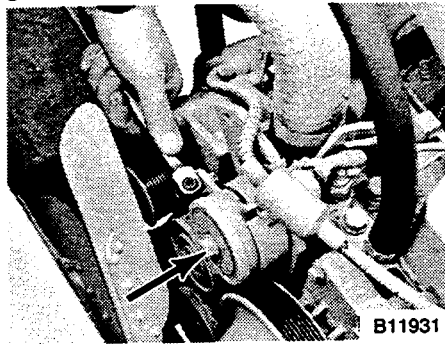

Slacken the tension roller and remove the fan belt.

Check the tension roller and pulley (the pulley must turn freely).

STEP 3

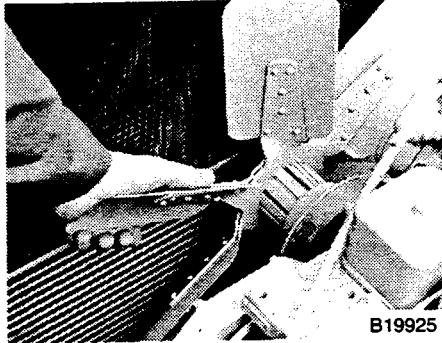

Check the fan operates correctly (the fan hub should turn freely, without excessive axial play).

STEP 4

Check the condition of the fan belt and replace it if worn or damaged.

STEP 5

Put the fan belt back in position.

STEP 6

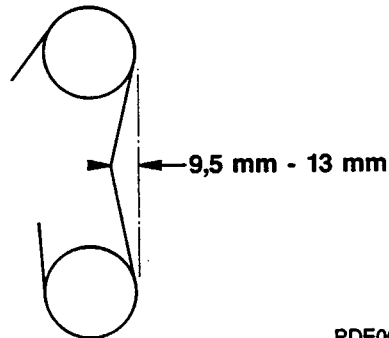

Measure the deflection of the belt along its longest straight section.

Maximum deflection.....9.5 to 13 mm

STEP 7

Install the fan guard and tighten it in position.

Replacing a battery

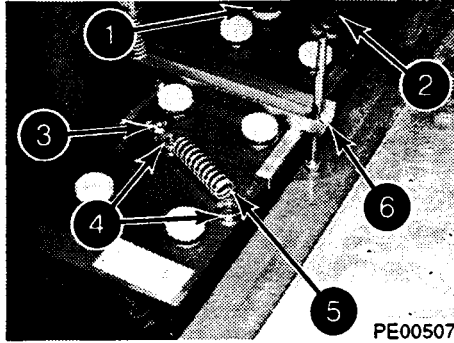

Removal

1. Disconnect the electrical circuit, using the battery master switch.
2. Remove the cover.
3. Remove the terminal covers.
4. Disconnect cables (1) and (2).
5. Remove anti-sulphate discs.
6. Loosen wing-nut (3).
7. Remove washers (4) and spring (5).
8. Remove fastening bracket (6).
9. Remove used battery.

Installing

1. Install the new battery
2. Install fastening bracket (6).
3. Install washers (4) and spring (5).
4. Install and tighten the wing-nut (3).
5. Clean the cables and connecting terminals and coat with vaseline.
6. Install new anti-sulphate discs.
7. Connect the cables (1) and (2) and install the covers.

NOTE : *Make sure that the positive (+) cables are connected to the positive (+) battery terminals, and the negative (-) cables are connected to the negative battery terminals (-). Do not invert the connections.*

8. Replace the cover.
9. Reconnect the battery to the electrical circuit using the battery master switch.

STARTER

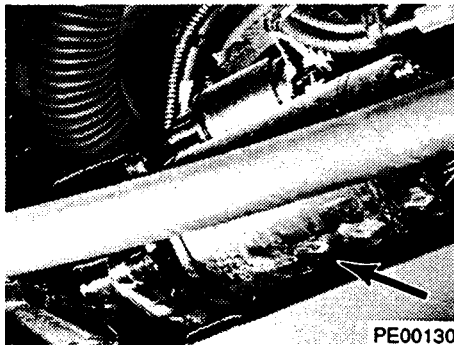

Every 1000 hours of operation.

Have the starter checked by your CASE POCLAIN dealer.

CLICK HERE TO **DOWNLOAD** THE COMPLETE MANUAL

- Thank you very much for reading the preview of the manual.
- You can download the complete manual from: www.heydownloads.com by clicking the link below



- Please note: If there is no response to CLICKING the link, please download this PDF first and then click on it.

CLICK HERE TO **DOWNLOAD** THE COMPLETE MANUAL