

Operator's Manual

Track excavator

ET16



Machine model	E09-02
Edition	1.0.1
Document order number	1000365220
Language	en
From serial number	WNCE0902PPAL00131



**WACKER
NEUSON**

CLICK HERE TO **DOWNLOAD** THE COMPLETE MANUAL

- Thank you very much for reading the preview of the manual.
- You can download the complete manual from: www.heydownloads.com by clicking the link below



- Please note: If there is no response to CLICKING the link, please download this PDF first and then click on it.

CLICK HERE TO **DOWNLOAD** THE COMPLETE MANUAL

Additional control circuits	Additional control circuits required for certain attachments. <ul style="list-style-type: none">• AUX I: auxiliary hydraulics (for example for hydraulic hammer or offset bucket)• AUX II: 3rd control circuit (for example for universal grab)• AUX III: for example Powertilt• AUX IV: hydraulic quickhitch (for example Easy Lock)• AUX V: oscillating grab
-----------------------------	--

Right/left/front/rear

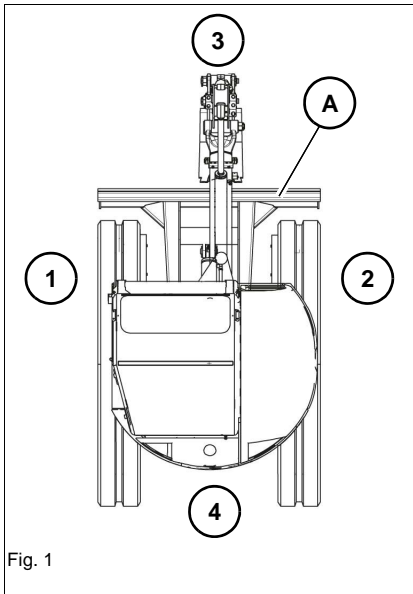

These terms are used from the view of an operator in the cabin if the front of the cabin faces toward the stabilizer blade **A**.

- 1: left
- 2: right
- 3: front
- 4: rear

Information

Any differences between the canopy and cabin are indicated separately. Otherwise, the terms **cab** or **cabin** are used.

Machine travel on public roads/sites

- The specific national driving license is required.
- Observe the national regulations (for example the road traffic regulations) during machine travel on public roads/sites.
- Ensure that the machine is in compliance with the national regulations.
- In order not to blind other motorists, using the existing work lights during machine travel on public roads/site is prohibited.
- When crossing for example underpasses, bridges, tunnels, ensure that the clearance height and width is sufficient.
- The attachment fitted onto the machine must be certified for travel on public roads/sites (see for example the registration documents).
- The attachment fitted onto the machine must be empty and in transport position.
- The attachment fitted onto the machine must be equipped with the mandatory lights and protective equipment.
- Take measures against unintentional operation of the operating hydraulics.
- If the machine has different steering modes, ensure that the mandatory steering mode is selected.

Stopping the engine of the machine

- Stop the engine only according to the Operator's Manual.
- Before stopping the engine, lower the work equipment/attachment to the ground.

Stopping and securing the machine

- Unbuckle the seat belt only after stopping the engine.
- Before leaving the machine, secure it to prevent it from rolling away (for example with the parking brake, suitable wheel chocks).
- Remove the starting key and secure the machine against unauthorized operation.

2.10 Measures for avoiding risks

Tyres

- Have repair work on the tires only performed by trained technical personnel.
- Check the tires for correct pressure and visible damage (for example cracks, cuts).
- Check the wheel nuts for tightness.
- Use only approved tires.
- The machine must have identical tires (for example profile, revolutions per mile).

Tracks

- Repair work on tracks may be performed only by trained technicians.
- Check the tracks for correct tension and visible damage (for example cracks, cuts).
- Proceed with extreme care on slippery ground (for example on steel plates, ice), increased slipping hazard.
- Use only approved tracks.

Hydraulic and compressed-air system

- Check all lines, hoses and threaded fittings regularly for leaks and visible damage.
- Splashed oil can cause injury and fire.
- Leaking hydraulic and compressed-air lines can cause the full loss of the brake effect.
- Have damage and leaks immediately repaired by an authorized service center.
- Have hydraulic hoses replaced by an authorized service center within stipulated intervals even if no visual defects can be detected.

Electrical system

- Use only fuses with the specified current rating.
- In case of damage or malfunction in the electrical system:
 - Put the machine out of operation immediately and secure it against restart
 - Disconnect the battery or operate the battery master switch
 - Have the malfunction repaired
- Ensure that work on the electrical system is only performed by trained technical personnel.
- Have the electrical system checked regularly and malfunctions repaired immediately (for example loose connections, scorched cables).
- The operating voltage of machine, the attachment and the trailer must be the same (for example 12 V).

3.4 Labels

 **WARNING****Injury hazard due to missing or damaged labels!**

A missing, incomplete or poor indication of danger can cause serious injury or death.

- ▶ Do not remove warning and information labels.
 - ▶ Immediately replace damaged warning and information labels.
-

 **Information**

Type, quantity, and position of the labels depend on options, country and machine.

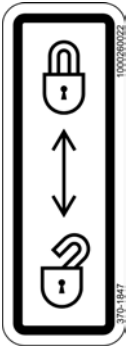

Fig. 29

Meaning

Hydraulic functions active or locked

Position

On control lever base

F2	F3	F4	F5	F6	F7	F8	F9
10A	10A	15A	10A	15A	10A	10A	15A

Fig. 30 (symbolic representation)

Meaning

Fuses and relays

Position

On the fuse box

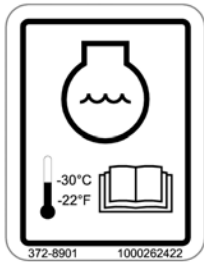

Fig. 31

Meaning

Coolant

Position

In the engine compartment on the right



Fig. 32

Meaning

Battery master switch

Position

In the engine compartment on the left

4 Putting into operation

4.1 Cabin

Safety instructions regarding entry and exit



CAUTION

Falling hazard when entering or exiting!

Entering or exiting incorrectly can cause injury.

- ▶ Keep the mandatory climbing aids **A** clean and use only them for entering and exiting.
 - ▶ Face the machine as you enter and leave it.
 - ▶ Have damaged climbing aids replaced immediately. Do not operate the machine.
-



CAUTION

Crushing hazard due to unlocked cabin door!

Unlocked cabin doors can cause crushing.

- ▶ Lock the cabin door.
 - ▶ Use the handholds for closing.
-



CAUTION

Injury hazard when opening or closing the front window!

Opening or closing the front window can cause injury.

- ▶ Use both handles.
 - ▶ Duck your head.
 - ▶ Let both locks lock into place.
 - ▶ Keep body parts and clothes away from the window channel.
-

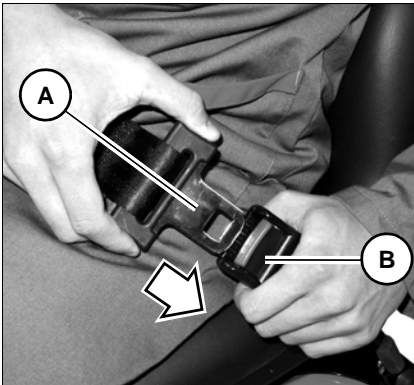

Fig. 80

Fastening the retracting lap belt

Insert buckle latch **A** into seat belt buckle **B** until it engages.

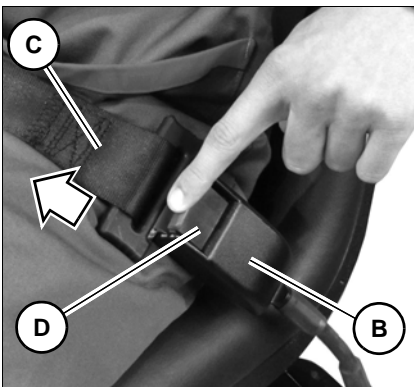

Fig. 81

Unfastening the retracting seat belt

Press the red push button **D** on seat belt buckle **B** until the buckle latch comes out.

- ➔ Seat belt **C** is automatically retracted.

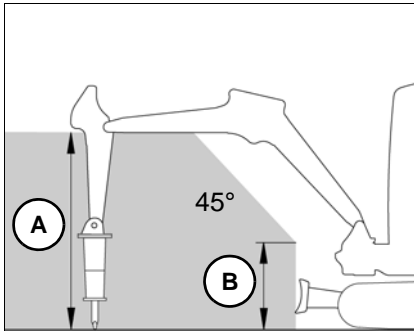

Fig. 90 (symbolic representation)

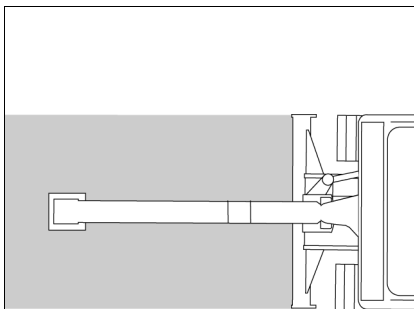

Fig. 91 (symbolic representation)

Job site

Work range height **A**: 120 cm (47 in), **B**: 50 cm (20 in)

Figures 90 and 91 refer to work with a Wacker Neuson hydraulic hammer. Working with another tool can result in a different work area.

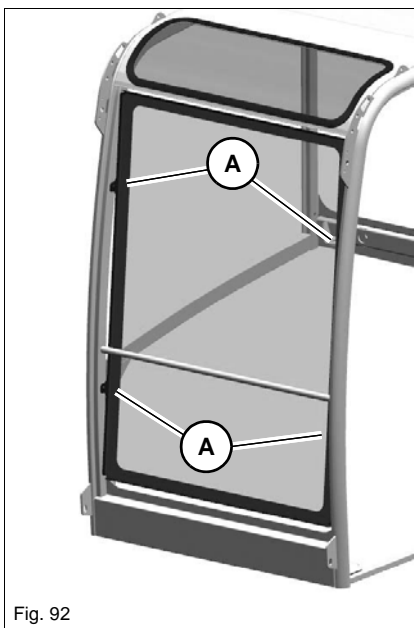

Fig. 92

Assembly

1. Stop and park the machine. Stop the engine. See "Preparing lubrication".
2. Tighten hexagonal bolts **B**(M8/8.8) to a torque of 25 Nm (18 ft./lbs.) at the tie-down lugs **A**.



Information

Two people are required for assembly.

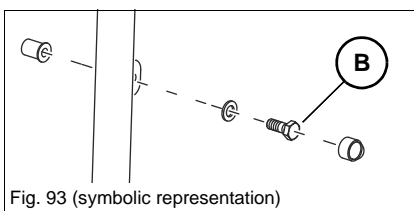

Fig. 93 (symbolic representation)

Check lists

The checklists below assist you in checking and monitoring the machine before, during, and after operation.

Wacker Neuson does not claim those lists to be exhaustive.

If the answer to one of the questions is **No**, first rectify the cause of the fault (or have it rectified) before starting work.

The checking and monitoring work listed below is described in greater detail in the following chapters.

Start-up checklist

Check and observe the following points before putting the machine into operation or starting the engine:

No.	Question	Page
1	Enough fuel in the tank?	7-26
2	Water in water separator and fuel filter checked and drained if necessary?	7-27
3	Correct engine oil level?	7-30
4	Coolant level OK?	7-32
5	Correct oil level in the hydraulic oil reservoir?	7-38
6	Glass cleaner in washer reservoir?	7-42
7	Lubrication points greased?	7-9
8	Tracks checked for cracks, cuts, etc.?	--
9	Light system, mirrors, signaling, warning and indicator lights operational and/or adjusted correctly?	--
10	Windows, mirrors, lights, steps, all pedals and control levers clean?	--
11	All control levers and pedals in neutral position?	--
12	Does the window washing system function correctly?	7-42
13	Control lever base raised?	4-35
14	Are other persons required to guide you?	--
15	Attachment safely locked?	5-30 5-43
16	Engine cover locked? Filler cap closed tightly?	7-15 7-26
17	Tools and other loose objects removed?	--
18	Seating position adjusted correctly?	4-7
19	Are all visual aids functional, clean and adjusted correctly?	4-12
20	Seat belt fastened?	4-10 4-11

Battery master switch

NOTICE

Possible damage to the electronics due to improper actuation of the battery master switch!

- ▶ Do not operate the battery master switch with a running engine.
- ▶ Operate the battery isolator switch no sooner than two minutes after shutting off the engine.

Actuate the battery isolator switch:

- If the vehicle is parked for longer periods of time (e.g. over the weekend).
- If the vehicle is to be protected against unintentional taking into service.
- If required by national and regional provisions.

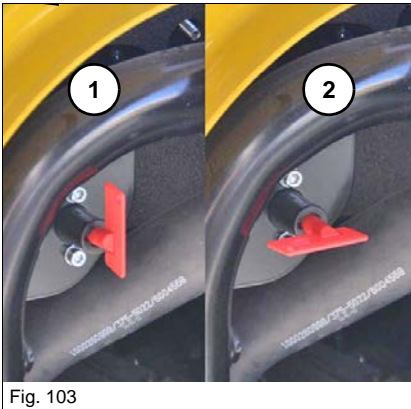

Fig. 103

The battery master switch is located in the engine compartment.

Power supply	Key position
Established	1
Interrupted	2 (key removed)

5.6 Lights/signalling system

WARNING

Accident hazard due to blinded motorists!

Working lights can blind motorists. This can cause serious injury or death.

- ▶ Stop machine operation if motorists are blinded.
- ▶ Take up operation again only when sufficient illumination of the working area is ensured without blinding motorists.

Working lights

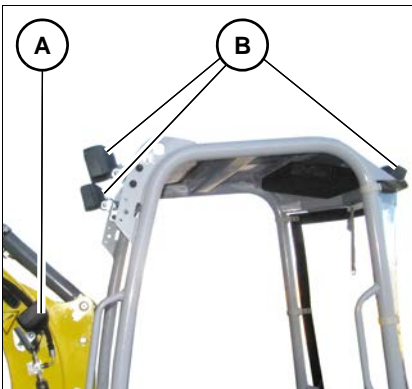

Fig. 113 (symbolic representation)

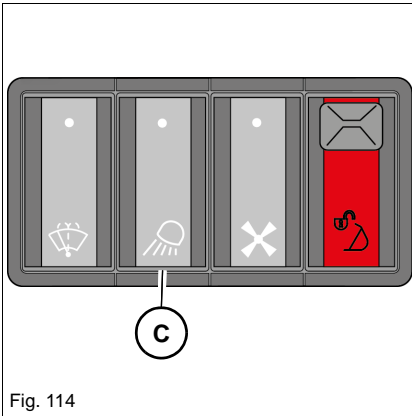

Fig. 114

Position	Designation
A	Boom light
B	Front and rear roof lights (option)

Information

With the **roof-mounted spotlight** option, all work lights are switched on and off together.

The switch is located on the switch panel.

Working lights	Operation
On	Press the switch C down
Off	Press the switch C up

Information

Switch on the working lights in conditions of poor visibility. If illumination still is not sufficient, use external lights. If this is yet not enough to illuminate the job site sufficiently, stop machine operation and only start it again when sufficient illumination can be ensured.

CLICK HERE TO **DOWNLOAD** THE COMPLETE MANUAL

- Thank you very much for reading the preview of the manual.
- You can download the complete manual from: www.heydownloads.com by clicking the link below



- Please note: If there is no response to CLICKING the link, please download this PDF first and then click on it.

CLICK HERE TO **DOWNLOAD** THE COMPLETE MANUAL

Telescopic travel gear

 **WARNING****Crushing hazard due to tipping over of machine!**

A tipping machine can cause serious injury or death.

- ▶ Only perform work with an extended telescopic travel gear.
 - ▶ Performing machine travel with a retracted telescopic travel gear is only allowed for machine travel over very short distances through passages. Pay attention to the reduced stability.
 - ▶ Raise the boom about 20 – 30 cm (8 – 12 in) off the ground and position it straight ahead at the center of the machine.
If a hose bursts on the telescopic cylinder, lower the boom immediately to prevent the machine from tipping over.
 - ▶ Extend and retract the travel gear only on horizontal, level and firm ground.
 - ▶ Retract or extend the telescopic travel gear completely.
-

 **WARNING****Danger of crushing when retracting the telescopic travel gear!**

Retracting and extending the telescopic travel gear can cause serious crushing of body parts and death.

- ▶ Do not allow anyone to stay in the danger zone.
 - ▶ Retract or extend the telescopic travel gear completely.
-

NOTICE

Damage to machine when travelling through passages.

- ▶ The dozer blade and telescopic travel gear must have the same width.
-

Preparation for hydraulic quickhitch (option)

The HSWS preparation is a hydraulic auxiliary control circuit attached to the vehicle boom that was designed, developed and released for the hydraulic quick coupler systems described in this operator's manual.

Wacker Neuson is not liable for injuries or damage if at least one of the following items is not complied with:

- Follow the operator's manual for the hydraulic quickhitch.
- Store the Operator's Manual of the hydraulic quickhitch together with the Operator's Manual of the machine.
- For non-released quickhitch systems, there may be differences in the operating functions or the operation of the vehicle - Observe the operator's manual of the quickhitch system or the attachment.

Nevertheless, should a non-released HSWS be used, the following points must also be observed:

- If required, modifications on the machine (for example additional adhesive labels) or the operator's manual of the machine (if operation is different) must be made.
- The intended purpose of the machine may be restricted.
- Assembling a hydraulic quick coupler system that does not fit with the vehicle or its interface (e.g. pressure settings) may void the declaration of conformity of the vehicle. Contact a Wacker Neuson service center.
- Assembling a hydraulic quick coupler system to a vehicle that does not fit with the vehicle or its interface (e.g. pressure settings) may void the declaration of conformity of the hydraulic quick coupler. Contact a Wacker Neuson service center.

Load-retaining function

 **WARNING**
Injury hazard due to fluid escaping under pressure!

Hydraulic oil escaping under pressure can penetrate the skin and cause serious injury or death.

- ▶ Do not allow anyone to stay in the danger zone.
 - ▶ If a hose bursts, move the control elements to neutral position so that as little hydraulic oil as possible escapes.
-

 **WARNING**
Burn hazard due to hot hydraulic oil!

Hot hydraulic oil can cause burns to the skin.

- ▶ If a hose bursts, move the control elements to neutral position so that as little hydraulic oil as possible escapes.
 - ▶ Wear protective equipment.
-

 **Information**

Hose burst valves are set at the factory and secured with seals. The correct functioning is no longer ensured and warranty is void if a seal is removed or if the hose burst valve is tampered with.

If a hose bursts, move the control lever or stabilizer blade lever to neutral.

Load-retaining function	Position
Stabilizer blade	Hose burst valve

Working with the bucket

The following section describes work operations with the machine equipped with a backhoe bucket. The backhoe bucket is mainly used for earth-moving applications (digging, loosening, picking up and loading loose or solid material).

Place the stabilizer blade on the side you want to dig.

Bucket position when digging

Perform long, level excavation movements with the stick and the bucket. The maximum excavation force is achieved at an angle of 80 to 120° between the boom and the stick.

1. Penetrate into the ground with the bucket.
2. Lower the stick and at the same time, position the bucket so that the flat lower side of the bucket is parallel with the ground.
3. Move the stick toward the machine and tilt in the bucket at the same time.

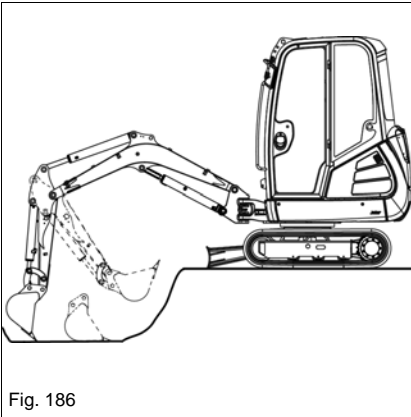

Fig. 186

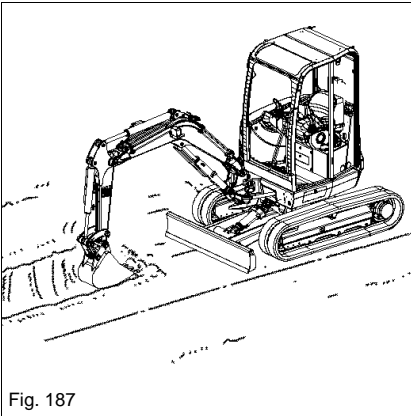

Fig. 187

Working alongside trenches

For a more efficient working method, install a suitable bucket and set the tracks parallel to the trench.

When digging wide trenches, dig the side sections first and then the middle section.

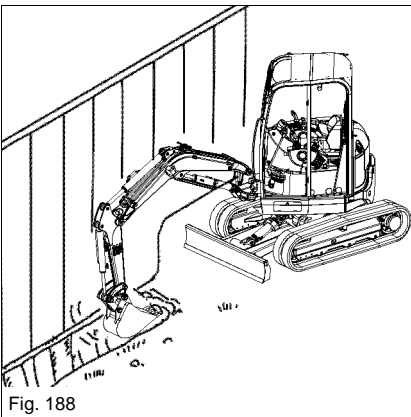

Fig. 188

For excavating laterally in tight spaces, turn the upper carriage and swivel the boom.

6 Transportation

6.1 Towing the machine



WARNING

Accident hazard due to incorrect towing!

Incorrect towing can cause accidents and serious injury or death.

- ▶ Tow the machine away only from the immediate danger zone until it can be loaded.
- ▶ Only tow the machine using suitable towing equipment in connection with suitable towing facilities, such as towing hooks, eyes, etc.
- ▶ There must be nobody between the vehicles during towing. The lateral safety distance is equal to 1.5 times the length of the towing equipment.
- ▶ Do not tow the machine if it is stuck or on a slope. Load the machine.
- ▶ Wear protective equipment.
- ▶ Start machine travel and tow away slowly.

NOTICE

The machine can be damaged during towing.



















- ▶ Tow the machine away only from the immediate danger zone until it can be loaded.
- ▶ Tow away the machine only if the engine is running and if the drive is functional.
- ▶ Do not tow the machine if it is stuck or on a slope. Load the machine.
- ▶ Only tow the machine using suitable towing equipment in connection with suitable towing facilities, such as towing hooks, eyes, etc.
- ▶ A tractor vehicle of the same weight category must be used as a minimum.
In addition, the tractor vehicle must be equipped with a safe braking system and sufficient tractive power.



Information

The manufacturer's warranty shall not apply to accidents or damage caused by loading or transporting.

Explanation of symbols on the maintenance label

Symbol	Assembly	Explanation
	General	Visual check
	General	Visual check of machine (walk-around)
	General	Lubrication points
	General	Clean the radiator fins and the water separator
	fuel system	Replace the fuel filter
	Radiator	Check the coolant
	Radiator	Draining coolant
	Engine	Check the engine oil level
	Engine	Changing engine oil
	Engine	Replacing the engine oil filter
	Engine	Replacing the V-belt
	Engine	Checking V-belt tension
	Engine	Replace the air filter element
	Engine	Checking valve clearance
	Travelling drive	Check the gearbox oil of the drive
	Travelling drive	Replace the gearbox oil of the drive
	Travel gear	Checking track tension
	Hydraulic system	Check the oil level of the hydraulic system
	Hydraulic system	Replace the hydraulic oil
	Hydraulic system	Replace the hydraulic oil filter insert
	Hydraulic system	Replace the breather filter of the hydraulic oil reservoir
	Cabin	Indicator lights are being checked
	Cabin	Resetting the maintenance meter

Replacement intervals

Replace the hydraulic oil and hydraulic oil filter depending on the percentage of hammer operation.

Percentage of hammer work	Hydraulic oil	Hydraulic oil filter
20%	800 o/h	300 o/h
40%	400 o/h	
60%	300 o/h	100 o/h
Over 80 %	200 o/h	

Important information regarding operation with biodegradable hydraulic oil

- Use only the biodegradable oils that have been tested and released by Wacker Neuson.
- Add only biodegradable oil of the same type. In order to avoid misunderstandings, attach a clear label to the hydraulic oil filler neck providing clear information regarding the type of oil currently used. The joint use of two different biodegradable oils can affect the quality of one of the oil types. Therefore ensure that the remaining amount of biodegradable oil complies with the national and regional regulations as you replace it. Observe the manufacturer's indications.
- Do not add mineral oil – the content of mineral oil should not exceed 2 % of the system fill in order to avoid foaming problems and to ensure biological degradability.
- When running the machine with biodegradable oil, the same oil and filter replacement intervals are valid as for mineral oil.
- Always have the condensation water in the hydraulic oil reservoir drained by a Wacker Neuson service center before the cold season. The water content may not exceed 0.1 % by weight.
- The instructions in this Operator's Manual concerning environmental protection are also valid for the use of biodegradable oil.
- Subsequent change from mineral oil to biodegradable oil may only be performed by a Wacker Neuson service center.

Engine oil types

Viscosity grade (SAE)	Ambient temperature			
	min. °C	min. °F	max. °C	max. °F
10W	-20	-4	10	50
20W	-10	14	10	50
10W30	-20	-4	30	86
10W40	-20	-4	40	104
15W40	-15	5	40	104
20	0	32	20	68
30	10	50	30	86
40	20	68	40	104

Engine compartment

1. Park the machine in a wash bay or place suitable for washing.
2. Stop the engine. See "**Preparing lubrication**".
3. Clean the machine.

Seat belt

Always keep the seat belt clean, as coarse dirt can impair the proper functioning of the seat belt buckle.

Clean the seat belt (while it remains fitted in the machine) with a mild soap solution only. Do not use chemical agents as they can destroy the fabric.

Cleaning in a saline environment

1. Park the machine in a wash bay or place.
2. See "**Preparing lubrication**".
3. Check the machine for salt deposits or corrosion. Have corrosion removed by a Wacker Neuson service center.
4. Clean the machine with a high-pressure cleaner. Clean the machine ensuring that there are no salt deposits in places that are difficult to access.
Bear in mind the information on cleaning and maintenance.
5. Lubricate the machine according to the lubrication plan.
6. Allow the machine to dry and check it again for salt deposits.

Loose threaded fittings and attachments

Contact a Wacker Neuson service center.

Cleaning the radiator

 **CAUTION****Burn hazard due to hot surfaces!**

Hot radiators can cause burns.

- ▶ Stop the engine and let it cool down.
 - ▶ Wear protective equipment.
-

NOTICE

Damage to diesel engine and hydraulic system due to dirt on the radiator.

- ▶ Check and if necessary clean the radiator once a day.
 - ▶ In dusty or dirty work conditions, clean more frequently than indicated in the maintenance plan.
-

NOTICE

Damage to radiator fins during cleaning.

- ▶ Keep a safe distance from the radiator during cleaning.
 - ▶ Use oil-free compressed air (2 bar/29 psi max.) to clean.
-

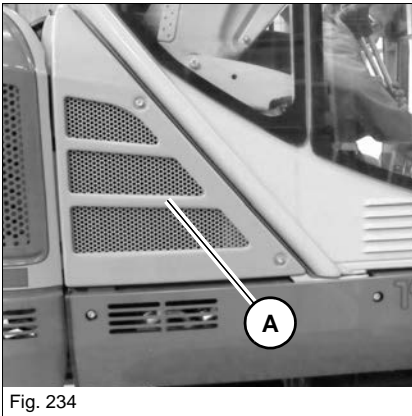

The radiators are located under the right side cover **A**.

1. Stop and park the machine. Stop the engine. See "Preparing lubrication".
2. Remove the right side cover **A**.
3. Remove dust and other foreign bodies from the fins with compressed air.
4. Attach the right side cover **A**.

7.18 Tracks

Checking track tension

WARNING

Crushing hazard during work under the machine!

Working under the tracks can cause serious injury or death.

- ▶ Do not allow anyone to stay in the danger zone.

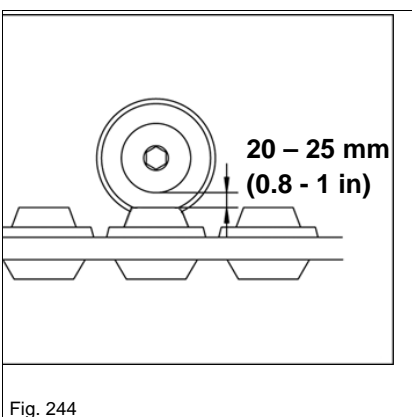
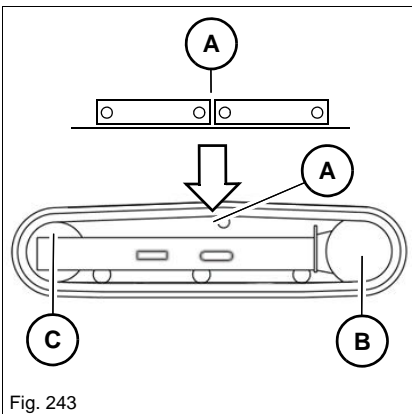
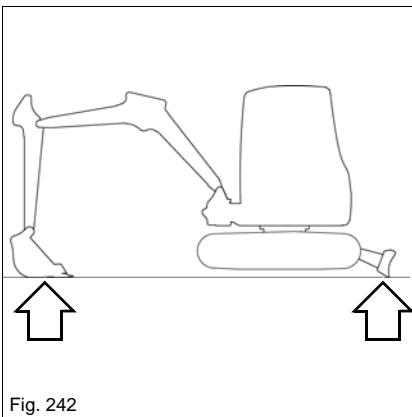

1. Park the vehicle on firm, level, and horizontal ground.
2. Raise the machine evenly and horizontally by means of the boom and stabilizer blade.
3. Place the tracks so that mark **A** is in the middle between drive pinion **B** and track tension roller **C**.
4. Stop the engine.
5. Operate the control lever repeatedly to release the pressure in the hydraulic system.
6. Raise the control lever base.
7. Remove the starting key and carry it with you.
8. Adjust the correct track tension if the play between the track roller and the track is not 20 – 25 mm (0.8 – 1 in).

9.3 Traveling drive/axles

	ET16
Travelling drive	Axial piston motor

9.4 Brake

See drive lever

9.5 Tracks

Type	Width mm (in)	Ground pressure kg/cm ² (lbs/in ²)	Ground clearance mm (in)
Rubber	230 (9)	0.26 (3.7)	180 (7)

9.6 Steering system

See drive lever

9.7 Operating hydraulics

Work hydraulics	ET16
Type of control	Load-pressure independent flow distribution (LIFD)
Number/type of pumps	1
Flow rate	33.3 l/min (8.8 gal/min)
Operating pressure for operating and travel hydraulics	200 bar (2,901 psi)
Swivel unit operating pressure	130 bar (1,886 psi)
Hydraulic reservoir capacity	20 l (5.3 gal)
Hydraulic oil quantity (system fill)	35 liters (9.2 gal)
Swivel range of upper carriage	360°
Rotation speed of upper carriage	9 rpm

Maximum speed

	ET16
Speed range 1	2.4 kph (1.5 mph)
Speed range 2	4.1 km/h (2.6 mph)

9.13 Weight

Machine weight

ET16 (canopy, standard travel gear, short shovel arm)	Weight kg (lbs)
Transport weight ¹	1402 (3,091)
Operating weight ²	1529 (3,371)

1. Transport weight: basic machine + 10 % fuel capacity.
2. Operating weight: basic machine + full fuel tank + bucket (300 mm/12 in) + user (75 kg/165 lbs).



Information

Weight indications can vary by +/- 2 %.

Determining the loading weight

The basis for calculating the loading weight is the shipping weight indicated on the machine nameplate. Add subsequently installed options and attachments (e.g. bucket, Easy Lock, breaker console) to the shipping weight. Add fuel depending on the tank capacity.

Option	Weight ¹ kg (lbs)
Cabin	90 (198)
Telescopic travel gear	88 (194)
FOPS screen category II	53 (117)
FOPS screen category I	14 (31)
Quickhitch-ready	8 (18)
Long stick	8 (18)
Shatter protection	5 (11)
Attachments – see chapter “ Technical data of attachments ” on page 9-15	
Full fuel tank	20 (44)

1. The weight indications for options exclusively refer to Wacker Neuson original accessories.

CLICK HERE TO **DOWNLOAD** THE COMPLETE MANUAL

- Thank you very much for reading the preview of the manual.
- You can download the complete manual from: www.heydownloads.com by clicking the link below



- Please note: If there is no response to CLICKING the link, please download this PDF first and then click on it.

CLICK HERE TO **DOWNLOAD** THE COMPLETE MANUAL