

Tigercat®

1055C/1075C/1085C FORWARDER OPERATOR'S MANUAL

SERIAL NUMBER 10551001–10551023

SERIAL NUMBER 10751001–10751126

SERIAL NUMBER 10850501–10850573



ISSUE 4.0, SEPTEMBER 2020

Tigercat Industries Inc.

P.O. Box 637

Brantford, Ontario

Canada N3T 5P9

Tel: (519) 753-2000

Fax: (519) 753-8272

CLICK HERE TO **DOWNLOAD** THE COMPLETE MANUAL

- Thank you very much for reading the preview of the manual.
- You can download the complete manual from: www.heydownloads.com by clicking the link below



- Please note: If there is no response to CLICKING the link, please download this PDF first and then click on it.

CLICK HERE TO **DOWNLOAD** THE COMPLETE MANUAL

Exhaust after treatment Devices (if applicable)

- Diesel Oxidation Catalyst (DOC)
- Diesel Particulate Filter (DPF)
- Selective Catalytic Reduction (SCR)
- Diesel Exhaust Fluid (DEF) tank and dispensing systems

Exhaust Gas Recirculation Systems (EGR)

- EGR valve assembly
- EGR cooler

Cold Start Enrichment Systems

Electronic Control Units, Sensors, Solenoids, and Wiring harnesses used in above systems

Emissions warranty does not cover

- Repairs arising from storage deterioration, failure to maintain the equipment, negligence, alteration, improper use of the equipment, collision or other accident, vandalism, or other casualty, or operation beyond rated capacity or specification.
- Repairs arising from abuse or neglect, including but not limited to: operation without adequate coolant or lubricants, adjustments to the fuel system outside equipment specifications, over-speeding, improper storage, starting, warm-up, or shutdown practices, incorrect fuel or contaminated fuel, oil or other fluids.
- Normal maintenance services, such as engine tune-ups, engine fuel system cleaning, checks, adjustments, shimming, etc.
- Items replaced due to customer demand.
- Labor charges performed by anyone except a dealer authorized by contract to repair the equipment, unless they qualify under special provisions (i.e. outside labor).
- Any and all travel costs for items such as towing, service calls, or transporting a unit to and from the place where the warranty service is performed. Unless otherwise specified on the standard engine warranty certificate.
- Normal maintenance costs, including but not limited to: lubricants, coolants, fluids, fuel, filters, and associated labor.
- Claims involving the inspection or reconditioning of units after storage or prior use.
- Repairs arising from service performed by agents not approved by Tigercat.
- Repairs arising from any unauthorized modification to the product or the use of non-Tigercat parts, implements or attachments.
- Removal, replacement, or installation of non-Tigercat optional equipment, attachments or components.
- Premiums charged for overtime labor costs or out of shop expenses.
- Economic loss including lost profits, crop loss, equipment rental, or other expense.
- Unauthorized modification or updating machines without a warrantable failure.
- Any and all costs of dealer shop supplies incurred with repairs, including but not limited to: solvents, cleaners, anti-seize lubricants, loctite, sealant, adhesive, oil-dry, shop towels, etc.
- Failure of the machine, its implements or attachments caused by improper field application or loading.
- Any and all costs for coolant, fuel, or lube (oil) analysis including supplies and lab recommendations.
- Cost associated with cleaning of machine in preparation for servicing.

VIBRATION AND NOISE LEVEL INSIDE CAB

Maximum Noise Level in Cab	
As per Tigercat test ETR00117	
Measured in accordance with	
ISO 5131:1996(E) Annex D	
Driving max speed (High)	
Σ	77.4 dB(A)
Driving max speed (Low)	
Σ	71.6 dB(A)



Wear suitable hearing protective device such as earmuffs or earplugs to protect against noise. Prolonged exposure to loud noise can cause permanent hearing loss. This machine exceeds 70dB(A) in the cab and exceeds 85dB(A) when servicing machine engine.

Check with your local Safety Commission to determine if hearing protection is required at these levels.

Vibration Level - Whole-body				
As per Tigercat test ETR037				
Measured in accordance with ISO 2631-1				
Weighted rms acceleration (m/s ²)				
	Seat		Seat-back	Feet
	Health	Comfort		
Driving max speed (High)				
x-axis (back-to-chest)	0.2120		0.7440	0.0388
y-axis (right-to-left)	0.4630		0.4700	0.0699
z-axis (buttocks-to-head)	1.3500		0.7580	0.1310
Σ	1.5300	1.4428	0.7110	0.0561
Driving max speed (Low)				
x-axis (back-to-chest)	0.1110		0.3290	0.0187
y-axis (right-to-left)	0.3030		0.4560	0.0455
z-axis (buttocks-to-head)	0.5210		0.4050	0.0657
Σ	0.6870	0.6128	0.4160	0.0290
Boom operation 1400 rpm				
x-axis (back-to-chest)	0.0344		0.0232	0.0096
y-axis (right-to-left)	0.1090		0.1550	0.0190
z-axis (buttocks-to-head)	0.0391		0.0992	0.0179
Σ	0.1650	0.1208	0.1110	0.0089

Vibration Level - Hand/Arm	
As per Tigercat test ETR037	
Weighted rms acceleration (m/s ²)	
Driving max speed (High)	
Σ	1.250
Driving max speed (Low)	
Σ	0.543
Boom operation 1400 rpm	
Σ	0.083

**Note for hand/arm, all weighted RMS acceleration values are below 2.5 m/s² as per clause 3.6.3 Machinery Directive 98/37/EC Annex 1.*

PARKING THE MACHINE

WARNING

To prevent injury, park the machine as outlined below.

- Park the machine on level ground **ONLY**. Do not park on a hill side or incline.
- Turn **ON** the parking brake.
- Set the travel direction switch to the neutral position.

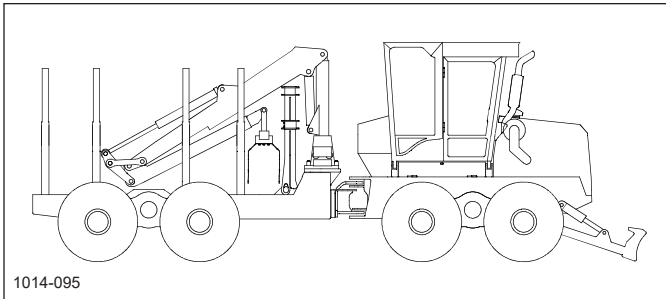

Crane in Park Position

Place the crane in the park position or on the ground.

- Lower the snow blade (if equipped) to the ground.
- Turn **OFF** the engine.
- Chock the wheels or take other steps to prevent the machine from moving.

If parking for an extended period:

- Turn the battery disconnect switch **OFF** and lock it in the **OFF** position if the disconnect switch is so equipped.
OR
Remove the key from the ignition.

PREPARING THE MACHINE FOR MAINTENANCE

WARNING

To prevent injury, prepare the machine as outlined below, prior to performing any maintenance or service activities.

- Park the machine as outlined in **PARKING THE MACHINE** in **THIS SECTION**.
- If working near the centre joint pinch point area, or on the steering circuit, install the articulation lock bar. Refer to **ARTICULATION LOCK** in **SECTION 2**.
- Before working on any hydraulic circuit, release accumulator pressure. Refer to **RELEASING ACCUMULATOR PRESSURE** in **THIS SECTION**.
- Turn **OFF** the coolant heater prior to:
 - working in the engine compartment
 - entering locations at which highly flammable gases or dust can form, and at which highly flammable liquids or soled materials are stored
 - entering enclosed spaces (garages)
 - welding

Disable the coolant heater permanently by removing the fuse located next to it.

FLUID INJECTION INJURY

WARNING

Diesel fuel or hydraulic fluid under pressure can penetrate the skin and could result in serious injury or death. If any fluid is injected under the skin, a medical doctor familiar with the treatment of this type of injury must surgically remove it within a few hours.

Hydraulic and diesel fuel systems on forestry machines operate at very high pressures, often 207 bar (3000 psi) and above. If a loose connection or a defect in a hose occurs, a fine, high velocity stream of fluid will result. Even for systems pressurized to as little as 7 bar (100 psi), this fluid stream can penetrate human skin as if it were a hypodermic needle.

Initially, an accidental fluid injection beneath the skin may only produce a slight stinging sensation. There is a danger that you will tend to ignore this, thinking that it will get better with time. Most often, it does not! Within a very short time the wound may begin to throb painfully, indicating that tissue damage has already begun.

Similarly fluid injected directly into a blood vessel can spread rapidly through your circulatory system. The human body has little ability to purge injected fluid.

Time becomes critical as tissue damage progresses rapidly. The longer you delay getting professional medical attention, the more damage can occur.

Although fluid injection accidents are rare, the resulting injury has on occasion required the amputation of a finger, a hand or in some cases the entire limb. The longer the delay in getting professional medical aid, the further up the limb the tissue damage can spread. An injury of this type can become very serious or even fatal if not dealt with promptly and properly.

IN THE EVENT OF ANY SUSPECTED FLUID INJECTION INJURY

- REPORT THE INJURY TO YOUR SUPERVISOR IMMEDIATELY.
- SEEK PROFESSIONAL MEDICAL ATTENTION IMMEDIATELY.

As always the best defence against suffering the effects of fluid injection is to prevent the accident from occurring in the first place.

SEARCHING FOR POSSIBLE FLUID LEAKS:

- Do not search for leaks with your bare hands. ALWAYS wear thick protective gloves.
- ALWAYS wear safety goggles for eye protection.
- Keep all body parts well away from the area being investigated for leaks.

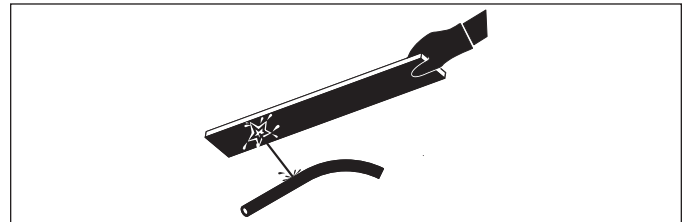

- Use the end of a long piece of wood to move hoses or other obstacles.
- Place the end of a long piece of wood in the suspected path of any fluid stream. Do not use any part of your body.
- Recognize that the source of the leak and the fluid streaming from it may be very small and not easily visible. You may only be able to see the fluid that accumulates as a result of the fluid stream.

WHEN PERFORMING ANY SERVICE WORK

- Stop the engine and relieve all diesel fuel or hydraulic pressure before disconnecting any lines or otherwise working on the system.
- Do not grab any hydraulic or diesel fuel connectors or hoses when they are subjected to pressure.
- Always verify that hoses are rated for the pressures to which they will be subjected.
- Do not use any hoses that you suspect could be defective.

NOTICE

Equipment fires undermine productive logging, may increase your insurance premiums dramatically, or prevent you from obtaining insurance coverage. Make fire prevention a priority.

HOW TO PREPARE FOR A MACHINE FIRE

- Inspect and maintain all machine systems on a routine basis.
- Maintain fire extinguishers in proper working order. Follow the manufacturer's instructions for inspection and maintenance (on the label of the fire extinguisher and in the user's manual).
- Verify that any pressurized water systems on the machine are charged and in working order. Refer to PRESSURIZED WATER SYSTEM MAINTENANCE as applicable in SECTION 3.
- Verify the correct types of fire extinguishers are available at the work site. Most fires involving mobile forestry equipment will be Class A or B. Dry chemical extinguishers should be rated ABC and pressurized water extinguishers should be rated A.
 - Class A fires involve ordinary combustibles such as wood, cloth, paper, rubber and many plastics,
 - Class B fires occur with flammable liquids such as diesel fuel, oil, and grease.
 - Class C fires apply to energized electrical equipment.
- The nozzles on fire extinguishers and pressurized water systems (if applicable) must fit within the fire extinguisher access ports on the machine doors.
- Keep the fire detection system in working order as applicable. Refer to FIRE DETECTION SYSTEM in SECTION 2.
- Keep the fire suppression system charged and in working order as applicable. Refer to FIRE SUPPRESSION SYSTEM in SECTION 2.
- Know the recommended fire procedures in your organization's emergency action plan.
- Follow all national, state/provincial, and local fire fighting regulations. Regulations will vary from region to region but most will require that:
 - Workers assigned to fire fighting duties must be physically capable of performing them safely and effectively.

- Workers designated to use fire fighting equipment as part of an emergency action plan must receive full and proper training from a qualified instructor.
- Whenever portable fire extinguishers are provided for use in the workplace, training must be provided to familiarize workers with the general principles of fire extinguisher use and the hazards involved with fire fighting.
- Training must be provided upon initial employment and at least annually thereafter.
- Know how to use the fire extinguisher, the pressurized water system (as applicable), and the fire suppression system (as applicable) on your machine. There is no time to read instructions during a fire emergency. Be prepared to act.
- Keep emergency contact information readily available in case of fire.

IN CASE OF A MACHINE FIRE

If a machine fire occurs:

1. Lower all working attachments to the ground.
2. Turn OFF the engine.

NOTE: If equipped, use the Emergency Engine Stop to override the Hot Engine Shutdown Prevention Strategy.

Activate the fire suppression system as applicable.

3. Radio or call for help. Report a fire immediately.
4. Turn OFF the battery disconnect switch if it safe to do so.
5. Dismount the cab; take the fire extinguisher and pressurized water system hose (if applicable) with you.
6. Put your personal safety and the safety of other persons first. Approach any fire with extreme caution. All fires are potentially very dangerous and life threatening.

Before deciding to fight the fire, be certain that:

1. The fire is small and not rapidly spreading.
2. There is a clear, safe escape route to your back.
3. You have received training in the use of the available fire extinguishing systems and are confident that you can operate them effectively.

If in doubt about your ability to fight the fire, do not attempt to fight it. Stay well back. Wait for help to arrive.

NOTE: Engine coolant, diesel fuel, or hydraulic hoses may fail during a fire. Hot coolant, fuel, or oil could be ignited, or may spray at high velocity from damaged hoses.

FIRE PREVENTION

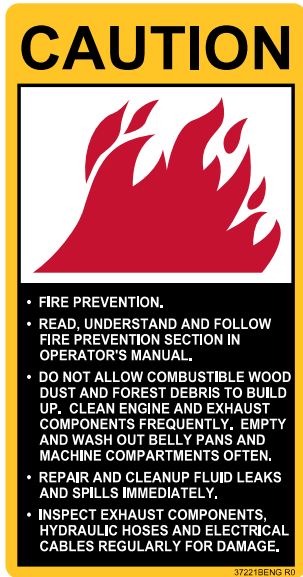

This label advises operator's of the following:

Read understand and follow the fire prevention guidelines in this manual. These guidelines provide all the necessary action required to preventing fires on this machine. Do not operate this machine until you have read these instructions and have performed any necessary maintenance required that will prevent the potential of a fire from starting on this machine.

It is also important to note that fire prevention inspections and maintenance must be performed frequently (several times per day). A clean combustible free machine as well as frequent inspections of the exhaust components, hydraulic hoses and electrical cables and performing any necessary repairs immediately will help prevent fires.

Maintain a charged fire extinguisher on the machine at all times, know where it is and know how to use it!

CHECK DAILY



In addition to the previous label this label is a reminder to check the machine daily for the possibility of debris build-up, leaks, damaged wires and hoses and take the necessary action required to clean up any debris accumulation, repair any leaks, damaged wires or hoses.

The label also advises to check and verify that all fire fighting devices are in good working order.



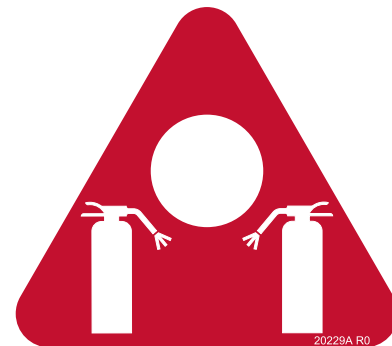

FIRE EXTINGUISHER ACCESS HOLE



This label indicates the location of each FIRE EXTINGUISHER ACCESS HOLE.

PICTOGRAMS

Diagrams in pictorial form are used to represent machine function operation. They are a simple universal language of symbols or pictograms that illustrate a function or component without the use of words.

Examples of these pictograms are the turtle  and the rabbit  that are often used to describe speed such as SLOW =  or FAST = .



Adjustment Menu



Air Conditioner ON



Air Conditioner OFF

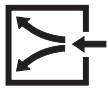

Air Source, Fresh Air



Air Source, Recirculate



Alert Message Symbol



All Wheel Drive ON/OFF



Battery CONNECT



Battery DISCONNECT



Blade DOWN



Blade Float ON/OFF



Blade UP



Brake



Control Lever, Multiple Direction



Control Lever, One Direction



Control Lever, Two Direction



Crane ON/OFF



Crane Main Boom DOWN



Crane Main Boom UP



Crane SWING RIGHT



Crane SWING LEFT



Crane Stick Boom DOWN



Crane Stick Boom UP



Crane Telescopic Boom EXTEND



Crane Telescopic Boom RETRACT



Crane Working Speed

n/min

FOOT PEDAL CONTROLS

The machine is equipped with two sets of foot pedal controls: front foot pedal controls and rear foot pedal controls. The operator’s seat rotates 225° from a forward facing position to a rearward facing position. The two sets of foot pedals provide the operator with drive control and brake control with the seat in either position.

The seat position is monitored by a sensor located in the seat frame. The sensor provides the computer control with the seat position signal. The computer control activates or deactivates the drive foot pedal controls relative to the seat position.

NOTE: Both brake pedals are always active regardless of seat position.

Refer to CAB CONTROLS–SEAT ROTATE LOCK/ UNLOCK SWITCH in THIS SECTION for more details.

NOTE: The front and rear foot pedal controls operate the same function, DRIVE FOOT PEDAL and BRAKE FOOT PEDAL.

⚠ WARNING

Use the seat belt when operating this machine.

DRIVE FOOT PEDAL

Pressing the RIGHT foot pedal increases engine speed.

With the travel direction switch in the forward or reverse position, pressing the drive foot pedal moves the machine. Read and fully understand the instructions before operating the machine. Refer to TRAVEL DIRECTION SWITCH in THIS SECTION for more information.

The position of the foot pedal in conjunction with the position of the gear selection switch (if equipped) is directly proportional to the travel speed of the machine. Refer to GEAR SELECTION SWITCH in THIS SECTION.

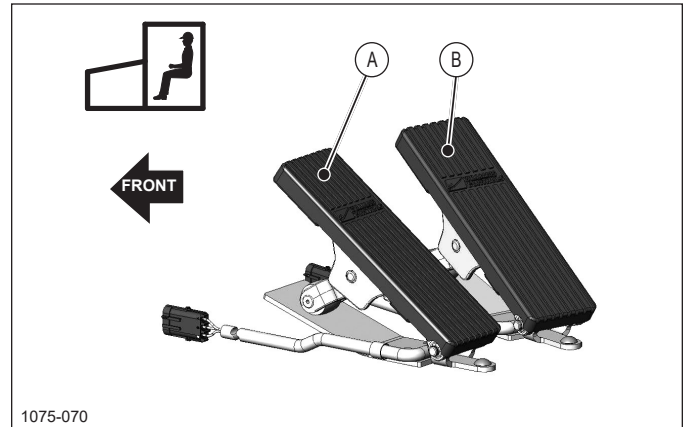

1075-070

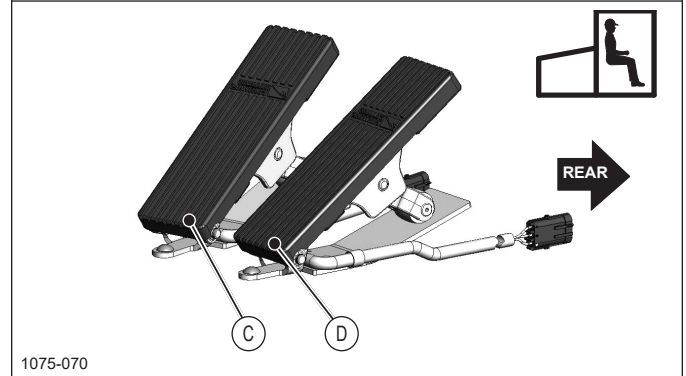

1075-070

Front/Rear Foot Pedals	
A	Front Brake Foot Pedal
B	Front Drive Foot Pedal
C	Rear Brake Foot Pedal
D	Rear Drive Foot Pedal

BRAKE FOOT PEDAL

Pressing the brake foot pedal applies the service brakes in the front and rear axles.

The brake lights (if equipped) will turn ON when the brake foot pedal is pressed.

The holding brake feature automatically engages the service brakes when the drive foot pedal is released and the machine stops. This feature may be turned off to avoid brake release delays in cold weather. Refer to COMPUTER–ADJUSTMENT MENU–MACHINE ADJUST–HOLDING BRAKE in THIS SECTION.

As a safety precaution use the brake foot pedal to release pilot system pressure before working on or around the machine. Stop the engine, turn the ignition key to the RUN position (do not start engine) and press the pilot reset switch, then apply the brake foot pedal 60 times or more. Connect a pressure gauge to test port G1 to verify that all pressure has been released from the accumulator. Pressure may remain in the system after completing all of the above steps. Use caution when loosening hydraulic connections.

Refer to RELEASING PILOT PRESSURE in SECTION 1.

TRAVEL/ENGINE SPEED ADJUST SWITCH

Press this switch to activate the maximum engine speed and maximum travel speed control dials. Press the switch again to deactivate them.

The travel/engine speed icon  on the main menu of the computer display is illuminated when this switch is ON.

Refer to MAXIMUM ENGINE SPEED CONTROL and MAXIMUM TRAVEL SPEED CONTROL in THIS SECTION for more information.

BLADE FLOAT SWITCH

The blade float feature, when engaged, allows the blade to “float” or follow the contours of the ground.

Press the blade float switch to ENGAGE the blade float function. Press it again to DISENGAGE the blade float function.

The blade float icon  on the main menu of the computer display is illuminated when the blade float feature is ENGAGED.

IMPORTANT !

Never use the blade (if equipped) to remove tree stumps or large boulders.

BLADE UP/DOWN SWITCH



WARNING

Do not raise the snow blade while the hood is open. The hood may close unexpectedly.

This is a three position momentary switch (BLADE UP/ NEUTRAL/ BLADE DOWN).

Place this switch in the BLADE UP position  and hold it to raise the blade.

Place this switch in the BLADE DOWN position  and hold it to lower the blade.

MAXIMUM ENGINE SPEED CONTROL

Sets the maximum allowable engine speed while travelling.

Turn ON the travel/engine speed adjust switch  to operate this feature, and then turn the control clockwise to increase the maximum engine speed setting, or counterclockwise to decrease the maximum engine speed setting.

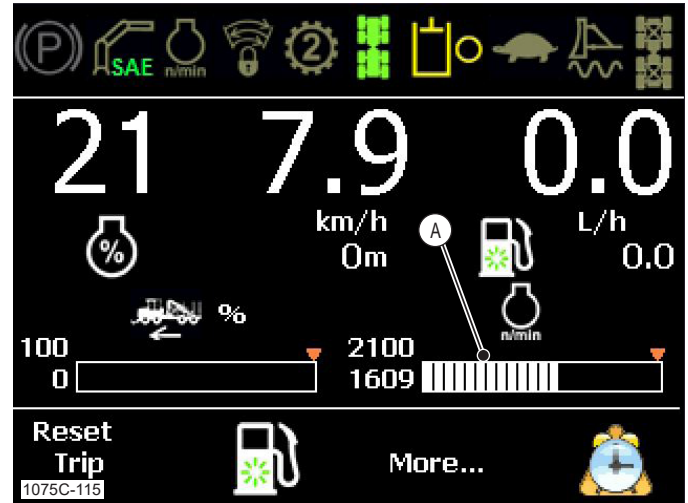

A Maximum Engine Speed Setting Indicator

The information screen is displayed while the rpm is being set. An orange indicator above the Engine RPM graphical display indicates the rpm selected.

The setting can be adjusted while the machine is in motion.

Refer to TRAVEL/ENGINE SPEED ADJUST SWITCH and COMPUTER–INFORMATION MODE MENU–MAXIMUM ENGINE SPEED SETTING INDICATOR in THIS SECTION.

AUDIO SYSTEM

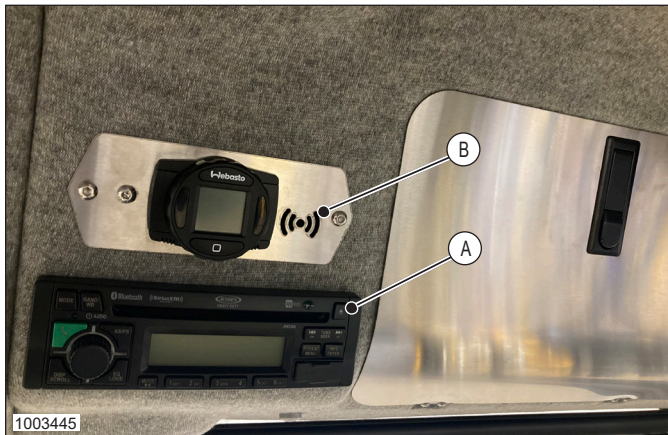

- A Radio
- B Microphone Location

The AM/FM/CD stereo radio includes a hands-free microphone and four overhead mounted speakers.

The AM/FM/WB/CD/RBDS/USB SiriusXM™ Ready and iPod™ Ready Stereo with Bluetooth® is located beside the upper right control panel.

BLUETOOTH FUNCTIONS

The radio includes built in Bluetooth technology that allows you to connect it to Bluetooth devices for streaming audio playback and hands free calling. The hands free microphone is located in the radio enclosure and is connected to the radio.

Refer to the MANUFACTURER'S DOCUMENTATION for complete operation instructions.



ADJUSTMENT MENU



From the main menu press F2 to select the adjustment menu.

The adjustment menu icon and the available adjustment selections are displayed.

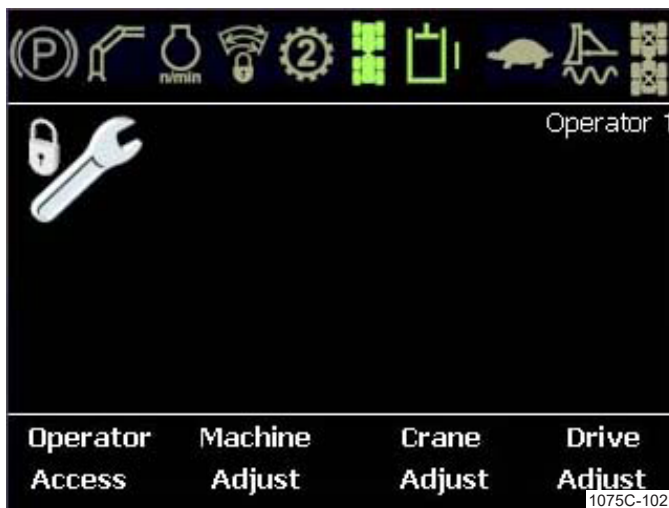

The adjustment selections are:

- Operator Access - Press F1 to select
- Machine Adjust - Press F2 to select
- Crane Adjust - Press F3 to select
- Drive Adjust - Press F4 to select

Press the back button to return to the main menu.

GENERAL CRANE ADJUSTMENTS

CRANE SPEED (%)

Crane speed is a single adjustment that sets the speed of all of the crane functions (except grapple open and close). Crane speed is the maximum speed setting of each crane function multiplied by the percentage displayed.

CRANE WORKING SPEED (RPM)

Set the Crane Working Speed to customize the rpm of the engine according to operating conditions/operator preference.

Alternately settings can be adjusted to make this minimum engine rpm setting available for travelling operations in addition to crane operation. In this case the crane working speed switch works independently of the crane on/off switch. Refer to COMPUTER-ADJUSTMENT MENU-CRANE ADJUST-GENERAL CRANE-WORKING SPEED ACTIVE ALWAYS.

WORKING SPEED ACTIVE ALWAYS

This setting toggles the operation of the crane working rpm switch from default to alternate settings.

If set to NO (default setting) the crane working rpm switch works with default computer settings which require that the crane on/off switch be used in conjunction with the crane working speed switch. In this case the minimum engine rpm setting is available only when operating the crane and the operator's seat is facing the crane.

If set to YES (alternate setting) the crane working rpm switch works independently of the crane on/off switch making the minimum engine rpm setting available for travelling operations in addition to crane operation, regardless of seat position.

The following crane functions can be adjusted to fine tune the operating speeds and start/stop ramps. In addition band width limiting and damping settings can be adjusted.

Refer to JOYSTICK CONTROL OUTPUT ADJUSTMENT SETTINGS in THIS SECTION for more information about how start slope, stop slope, fine control, BWL and damping settings affect function performance.

Refer to CRANE ADJUSTMENT SETTINGS REFERENCE CHART in SECTION 3 for range and default setting information.

MAIN BOOM STOP CUSHION +/- (TIGERCAT CRANE ONLY)

This setting adjusts the performance of the main boom stop cushion function. This function uses the signal from the main boom proximity sensor to reduce main boom speed as the boom approaches the limit of cylinder stroke. A lower setting will result in a harder main boom stop impact. A higher setting will result in a softer main boom stop impact.

STICK BOOM STOP CUSHION +/- (TIGERCAT CRANE ONLY)

This setting adjusts the performance of the stick boom stop cushion function. This function uses the signal from the stick boom proximity sensor to reduce stick boom speed as the boom approaches the limit of cylinder stroke. A lower setting will result in a harder stick boom stop impact. A higher setting will result in a softer stick boom stop impact.

SLEW (CRANE SWING)

Slew adjustments are used to customize the crane swing functions +RIGHT/-LEFT.

MAIN BOOM

Main boom adjustments are used to customize the main boom function +UP/-DOWN.

STICK BOOM

Stick boom adjustments are used to customize the stick boom function +UP/-DOWN.

TELESCOPE

Telescope adjustments are used to customize the main boom function +EXTEND/-RETRACT.

GRAPPLE ROTATE

Grapple rotate adjustments are used to customize the grapple rotate function +CW/-CCW.

GRAPPLE OPEN/CLOSE

Grapple open/close adjustments are used to customize the grapple open/close function +OPEN/-CLOSE.

RESET UNLOAD POINT–JOYSTICK POD

To reset the unload point feature using the left joystick pod, perform the following steps:

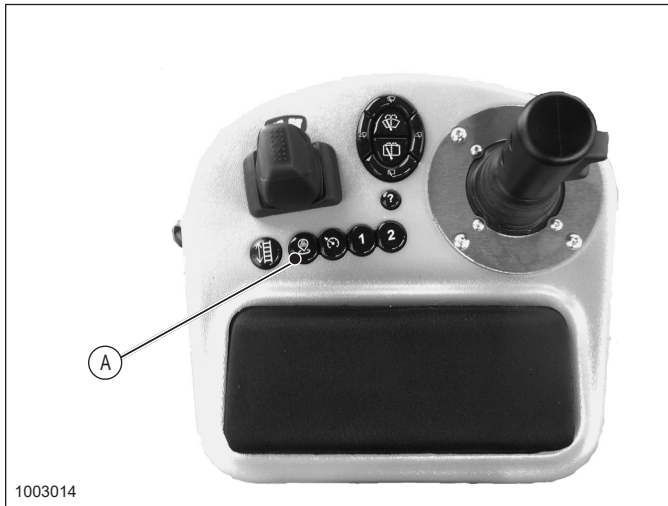

Left Joystick Pod
A Unload Point Button

1. Press the Unload Point Button on the left joystick pod.

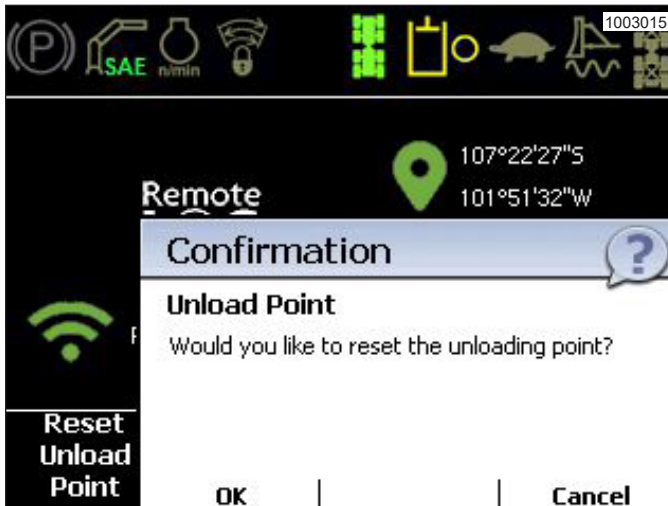

2. In the confirmation screen, press F2 to select OK to reset the unload point.

RESET LOAD COUNT

To reset the load count, perform the following steps:



1. From the main menu press F3 to select the information menu icon (i).



2. Press F3 to select More.

The following screen will be displayed.



SLEW DAMPING

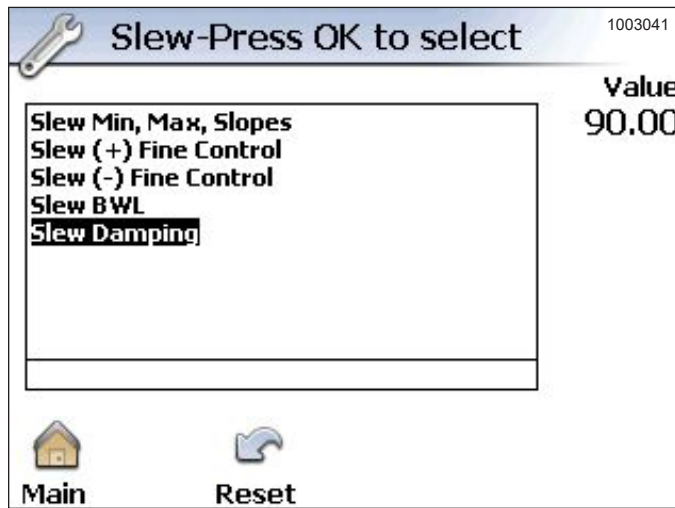

Press the UP or DOWN arrow buttons to select Slew Damping.

Press the OK button to make the selection.

MAIN BOOM

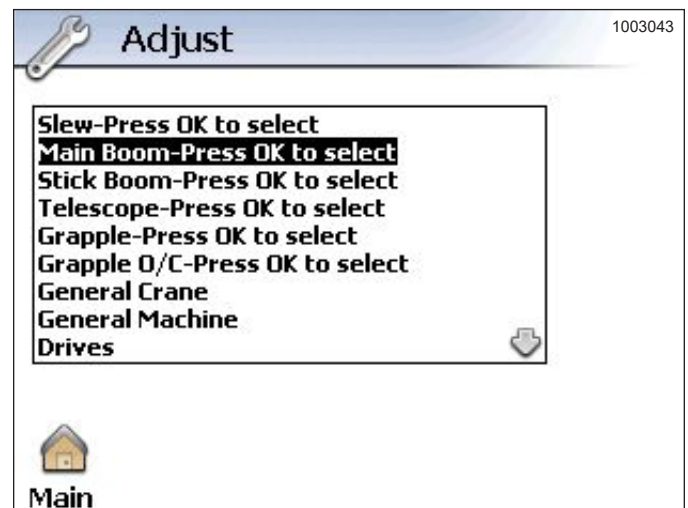

Press the UP or DOWN arrow buttons to select Main Boom.

Press the OK button to make the selection.

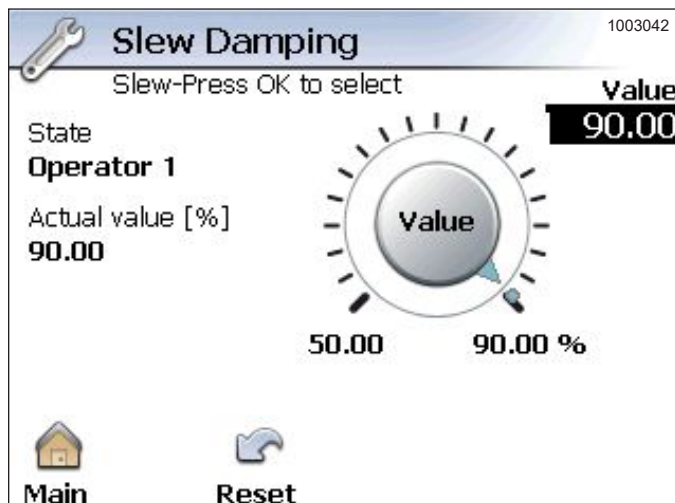

Press the UP or DOWN arrow buttons to increase or reduce the Slew Damping percentage value.

Press OK to set the value.

Damping values control the joystick response time.

A low damping value results in quick response.

A high damping value results in a slower response.

Inexperienced operators may want to adjust damping to a higher value. Once operators are comfortable with operating the function, the damping values can be reduced to a desired level, based on operator preference.

Press F2 to reset the value.



Refer to information on the previous pages for details on the above options.

COLD IDLE SPEED

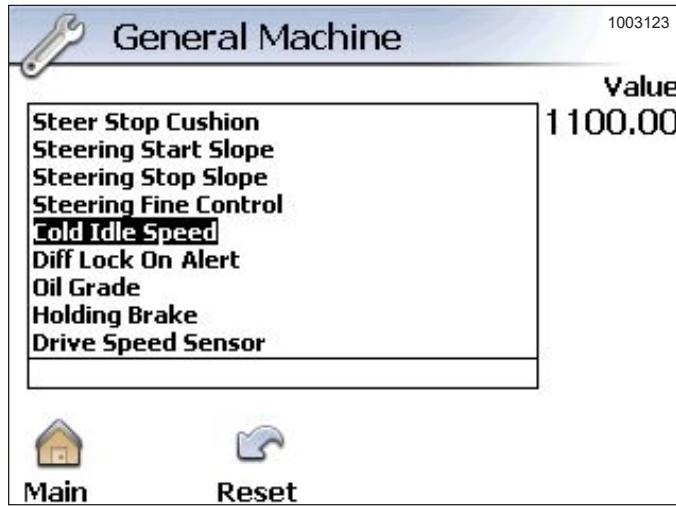

Press the UP or DOWN arrow buttons to select Cold Idle Speed.

Press the OK button to make the selection.

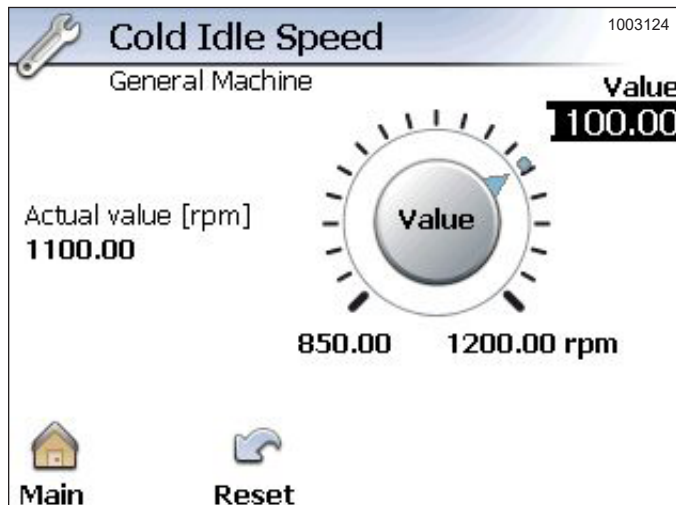

Press the UP or DOWN arrow buttons to increase or reduce the Cold Idle Speed rpm value.

Press OK to set the value.

The Cold Idle Speed can be adjusted from 850 to 1200 rpm.

Press F2 to reset the value.

DIFF LOCK ON ALERT

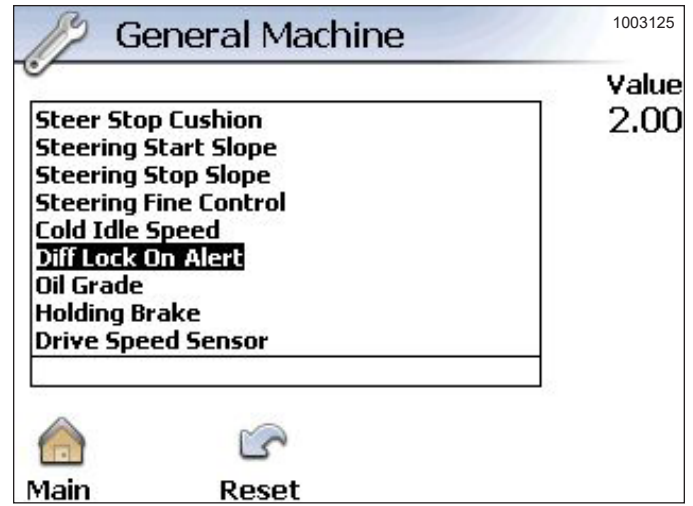

Press the UP or DOWN arrow buttons to select Diff Lock On Alert.

Press the OK button to make the selection.

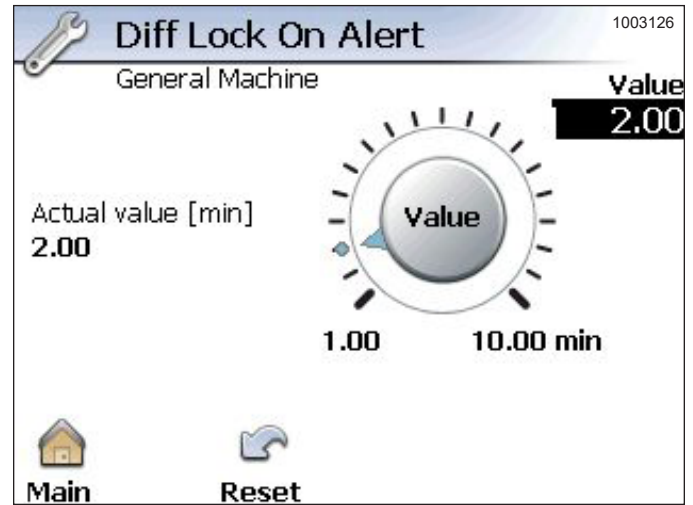

Press the UP or DOWN arrow buttons to increase or reduce the Diff Lock On Alert minute value.

Press OK to set the value.

This function sets the time that the Differential Lock is on before an alert message is displayed.

Differential lock icons on the main menu identify whether the front or rear differential locks are engaged.

IMPORTANT!

Use differential locks sparingly. Never drive the machine with the differential locks on continuously. Serious damage to the axles can result from using the differential locks when they are not needed for additional traction.

Press F2 to reset the value.

MEASURE MENU

Various values are measured and displayed to assist when troubleshooting.

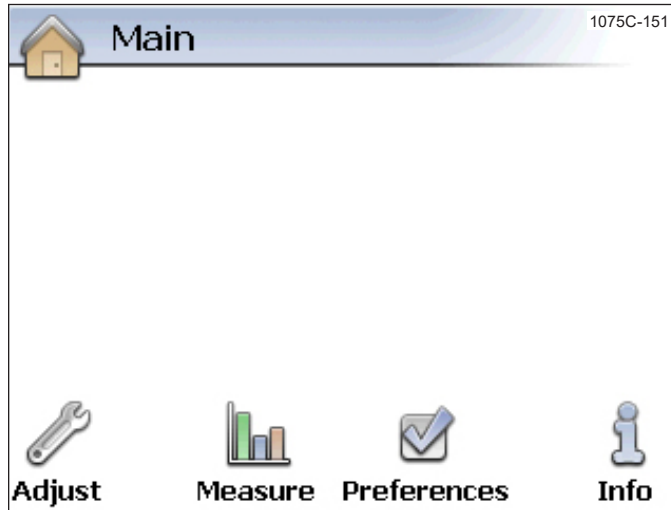

1. Press F2 to access the Measure Menu from the Main Screen.

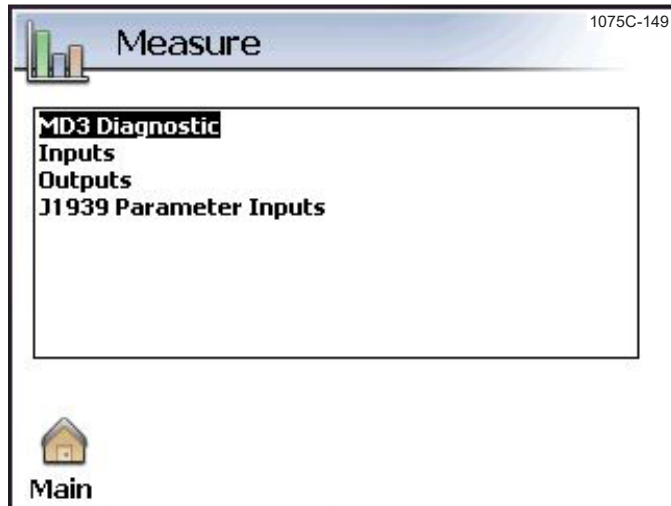

2. Press the Arrow Up/Down buttons to highlight a menu item. Press OK to select the item.

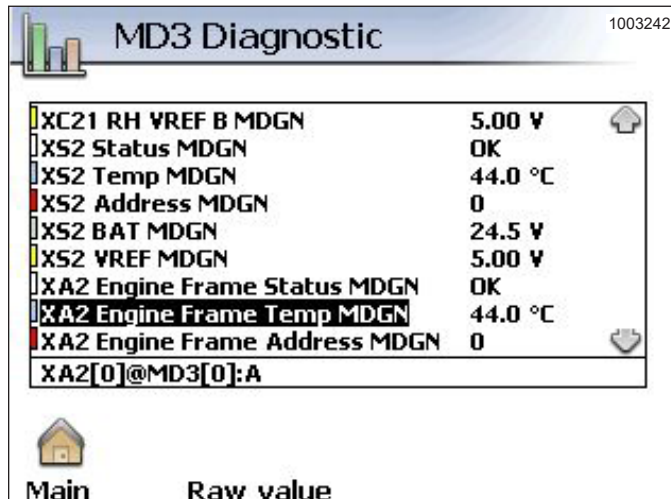

3. Press the Arrow Up/Down buttons to select an item.
The grey arrow(s) on the right side of the screen indicate that more items can be viewed above or below those currently displayed.

Additional information is provided for most items selected.

Examples:

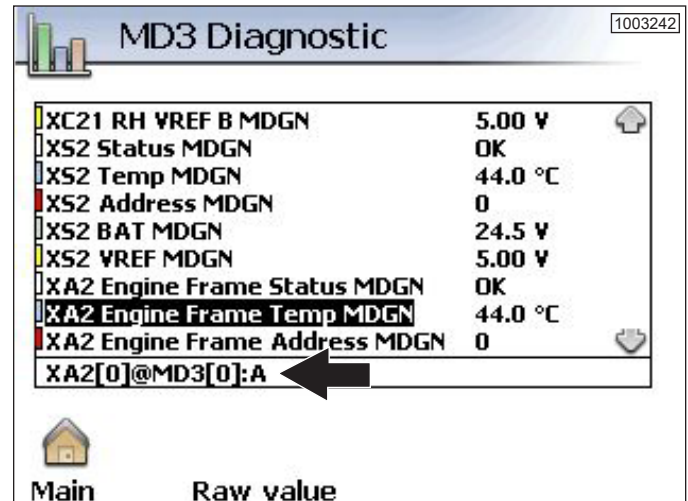

The signal is from the XA2-A0 module to the computer on CAN-Bus A.

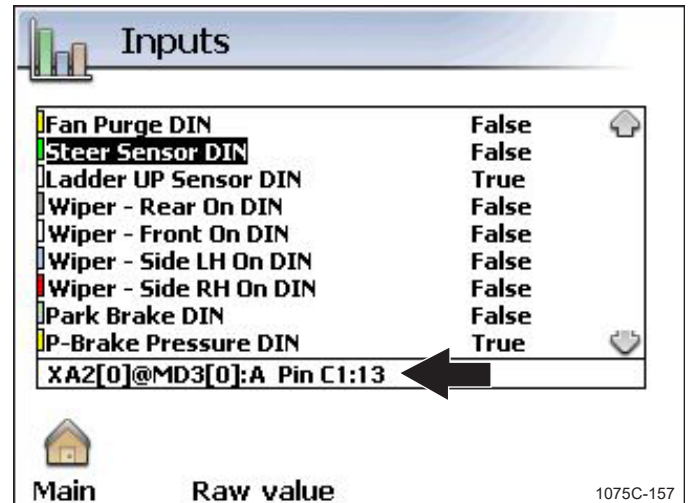

The signal is from the XA2-A0 module at Pin C1:13 to the computer on CAN-Bus A.

4. Press F2 to toggle between scaled values and raw values.

Raw values are the actual output values generated by a device and measured by the control system, typically in millivolts.

Scaled values are converted from millivolts to more useful information.

CRITICAL MESSAGES (RED)

Critical messages advise the operator that a critical machine fault is about to occur or a system fault has occurred.

Critical messages have the highest level of priority and are used to alert the operator that immediate action must be taken to prevent damage to the machine or to ensure operator safety.

The message provides details of the fault and may describe any necessary corrective actions.

When a critical message is displayed, the alarm sounds and alarm light flashes continuously.

Press F2 to hide the screen.



The critical symbol  flashes to indicate an active critical message is hidden. It will continue to flash until the problem is resolved and the fault becomes inactive.

Review active hidden messages by pressing F4 on the main menu display or when the critical symbol is displayed above the F4 button.

The operator may need to stop the machine and shut the engine off immediately to prevent damage to the machine. The operator may continue to operate the machine and move it to a safe location if it cannot be stopped immediately for safety reasons.

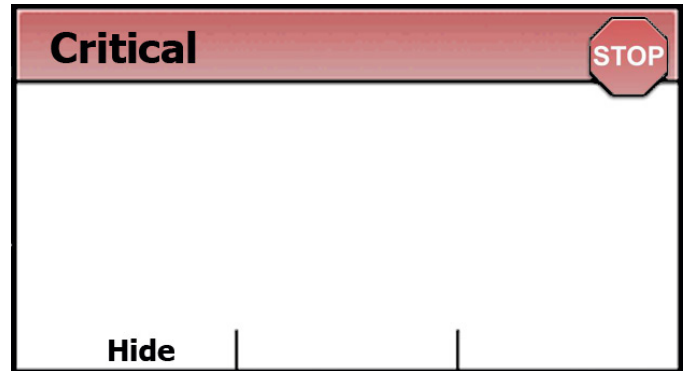

Critical messages:

- Engine Speed
- Hydraulic Oil Temperature High
- Steer Joystick Malfunction
- Interlock System Door open
- Hydraulic Oil Level Low.
- IQAN Module Fault
- Engine Coolant Temperature High
- Engine Coolant Temperature High - Engine Derate
- Engine Coolant Level low
- Aftertreatment System Technical Failure*
- Aftertreatment System Engine Idle Too Long*
- Engine Locked Out*
- Engine Restarts Remaining Until Engine Lockout*
- Engine Oil Pressure Low
- Engine Oil Pressure Low - Engine Derate
- Engine Oil Temperature High
- Engine Fault Code Messages - Critical
- Hydraulic Motor Speed - Damaging Speed Detected
- Main Fuel Filter Clogged
- Engine Boost Pressure Low - Engine Derate

***NOTE:** The aftertreatment system and its related components are applicable to Tier 4f machines only.

HYDRAULIC MOTOR SPEED

Critical		
Hydraulic Motor Speed		
Damaging speeds detected. Reduce travel speed to protect drive components.		
Hide		

Reduce travel speed immediately to protect drive components.

**ENGINE BOOST PRESSURE LOW
ENGINE DERATE**

Critical		
Engine Boost Pressure		
Boost Pressure Low - Engine Derate		
Hide		

Engine derate is triggered due to low engine oil pressure. This message may be accompanied by Engine Fault Code Messages related to engine oil pressure.

This message results in the following derate sequence:

1. When engine oil pressure readings fall below 1.2 bar (17 psi) for more than 5 seconds this message is shown and the engine will immediately begin to derate, reducing power to a level that will allow the operator to safely stop the machine. Do not continue to operate machine.

Safely stop the machine and turn the engine OFF. Refer to ALARM MESSAGES–CRITICAL–ENGINE OIL PRESSURE LOW in THIS SECTION for recommended corrective action. If the problem continues contact dealer for service.

2. When engine oil pressure readings rise above 1.4 bar (20 psi) for more than 5 seconds this message will turn OFF and the engine will automatically ramp up power to full operating speed.

NOTE: An Engine Torque Derate Active message is triggered as the engine begins to derate. Refer to ALARM MESSAGES–CRITICAL–ENGINE TORQUE DERATE ACTIVE.

MAIN FUEL FILTER CLOGGED

Critical		
Main Fuel Filter		
Clogged - Engine Derate		
Hide		

The main fuel filter is clogged. Replace the main fuel filter.

Refer to CHANGING THE ENGINE FUEL FILTER in SECTION 3.

CLICK HERE TO **DOWNLOAD** THE COMPLETE MANUAL

- Thank you very much for reading the preview of the manual.
- You can download the complete manual from: www.heydownloads.com by clicking the link below



- Please note: If there is no response to CLICKING the link, please download this PDF first and then click on it.

CLICK HERE TO **DOWNLOAD** THE COMPLETE MANUAL

ENGINE VOLTAGE LOW

Alert 	
<p>SPN: 8801 1 of 1 Engine voltage low.</p>	
Hide	

Engine voltage readings of less than 20 volts are detected.

Investigate the cause immediately.

ENGINE VOLTAGE HIGH

Alert 	
<p>SPN: 4449 1 of 1 Engine voltage high.</p>	
Hide	

Engine voltage readings of greater than 30 volts are detected.

Investigate the cause immediately.

ENGINE COOLANT TEMPERATURE HIGH

Alert 	
<p>SPN: 62755 1 of 1 Engine coolant temperature high.</p>	
Hide	

The engine temperature exceeds allowable engine temperature.

Investigate the cause immediately.

Check for:

- Plugged air intake access panel screens
- Plugged radiator.

Refer to CLEANING THE COOLER PACKAGE in SECTION 3.

Navigate to ALARM MESSAGES–CRITICAL–ENGINE COOLANT TEMPERATURE HIGH.

FUEL - WATER IN FUEL

Alert 	
<p>SPN: 17429 1 of 1 Water in Fuel.</p>	
Hide	

Water is detected in the fuel by the engine computer system.

Refer to engine manufacturer’s manual for specific information regarding the engine.

INPUT INTERLOCK

Information 	
Interlock System	
Input Interlock. De-activate input to operate machine.	
OK	

The Pilot Interlock is open (has not been reset) when an attempt was made to operate a pilot controlled function.

The Pilot Interlock prevents operation of pilot operated machine functions.

Operation is prevented until the control is released.

CRANE INPUT INTERLOCK CONTINUED

JOYSTICK CALIBRATION

Only machines with these serial numbers use joysticks that require calibrating.

1075C:
10751016 to 10751020, 10751028 and up

1085C:
10850504 to 10850510, 10850514 and up

1055C:
All machines

Verify this by displaying the measure screen and viewing each joystick inputs to the computer. This also identifies the joystick causing the alarm.

Refer to MEASURE MENU in THIS SECTION for information about how to measure the joystick inputs to the computer.

Refer to JOYSTICK CALIBRATION in THIS SECTION as well as CALIBRATING THE JOYSTICKS in SECTION 3 and SECTION 6 of the SERVICE MANUAL for additional information on calibrating the joysticks.

CRANE INPUT INTERLOCK

Information 	
Interlock System	
Crane Input Interlock. De-activate crane input to operate.	
OK	

One or more joystick controls are activated before the crane on/off switch is activated. Crane operation is prevented until all crane controls are de-activated.

This interlock prevents accidental activation of the crane controls.

Verify that each joystick is at its rest position. If necessary, slightly move each joystick to its centre/rest position to clear the message and begin using the crane.

A joystick may require replacing or calibrating (later joystick design only) if this message is displayed frequently.

Refer to CALIBRATING THE JOYSTICKS in SECTION 3.

DRIVE INPUT INTERLOCK

Information 	
Interlock System	
Drive Input Interlock. Release drive pedal to drive.	
OK	

The Pilot Interlock is open (has not been reset) when the drive foot pedal was activated.

Driving the machine is prevented until the drive foot pedal is released.

This interlock prevents accidental machine movement.

STARTING THE MACHINE

Perform lubrication and maintenance activities, as outlined in SECTION 3, before operating the machine.

Refer to the ENGINE OPERATION AND MAINTENANCE MANUAL for additional maintenance activities.

Any personnel operating this machine must first be fully trained in safety and operating procedures by a competent person.

Read and understand the entire manual before operating the machine.

PRESTART CHECKS

1. Turn ON the battery disconnect switch.
2. Place emergency engine stop in OFF position (OFF = Switch 'UP').
3. Place the ignition switch in the  RUN position (engine NOT running) to provide power to the computer system. Check for alarms on the computer display and investigate the cause. Refer to ALARM MESSAGES in THIS SECTION.



4. Amerex fire suppression system (if equipped): Verify that the green System OK status LED is illuminated.
Dafo fire suppression system (if equipped): Verify that the green System Power LED is illuminated

5. Check fuel gauge and DEF level indicator (if applicable).
Refer to FUEL TANK CAPACITIES in SECTION 3.

NOTE: DEF level indicator and its related components are applicable to TIER 4f machines only.

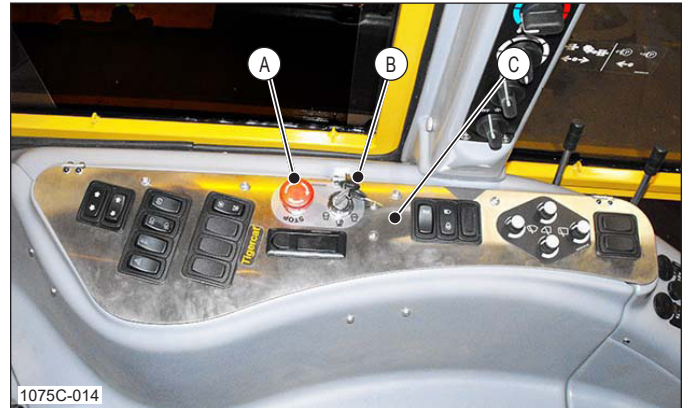

- A Emergency Engine Stop
- B Ignition Switch
- C Main Control Panel

6. When computer checks are complete place ignition switch in the OFF position.
7. Remove the ignition key.



Crane Slew Oil Level (Ealier Design)

- A Upper Sight Glass
- B Lower Sight Glass

OPERATING THE MACHINE



Read and understand all general machine operation safety rules prior to operating the machine.

LOAD SENSING

This machine is equipped with a load sensing system for the primary hydraulic functions.

A load sensing system causes the speed of a given function to be constant for a given control input regardless of the load.

The load induced pressure downstream of a valve's orifice is sensed by the system. Pump flow is automatically adjusted to maintain a constant pressure.

A constant pressure results in a constant flow of oil across the orifice.

A constant flow of oil results in a constant speed.

For example:

If a joystick is moved 20% of its travel for a given crane function, the system will provide whatever pressure is required (up to maximum if necessary) to cause the crane to move at a certain speed regardless of whether the crane is fully loaded or empty.

If crane movements feel jerky, moving the joystick beyond its required position is likely the reason. Instead move the joystick to a position and wait for the crane to respond.

If limiting joystick inputs doesn't eliminate the roughness, the margin pressure setting could be too high.

Reducing the margin pressure will reduce the machine's response.

Refer to SET MARGIN PRESSURE in SECTION 12 of the SERVICE MANUAL.

Refer to SET FLOW (FUNCTION SPEED) RATE in the appropriate BOOM, SWING or TRACK DRIVE sections.

TRAVELLING WITHOUT A LOAD

1. Place the crane in the park position and raise the snow blade (if equipped).
2. Set the CRANE switch to OFF.
3. Set the TRAVEL DIRECTION switch to FORWARD or REVERSE. As required, activate the TRAVEL/ENGINE SPEED ADJUST SWITCH and adjust the MAXIMUM TRAVEL SPEED CONTROL setting to suit the terrain.
4. Operate the drive foot pedal to move the machine.
5. This machine is equipped with a single-axis proportional steering control lever. The speed that the vehicle responds to the steering control lever input will vary, depending on the distance that the steering control lever is moved. When operating on the road, a short movement of the steering control lever will not overcorrect and will steer a reasonably straight course. Operating in the woods requires quick steering changes and this is produced by a larger movement of the steering control lever, which will quickly change the vehicle's direction.
6. Use differential locks sparingly and ONLY when additional traction is required. Never continuously drive the machine with the differential locks on. Serious damage to the axles can result from using the differential locks when they are not needed for additional traction.

IMPORTANT !

Use differential locks sparingly. Never drive the machine with the differential locks on continuously. Serious damage to the axles can result from using the differential locks when they are not needed for additional traction.

LOW-WIDE RAMP BUNK - 1075C/1085C

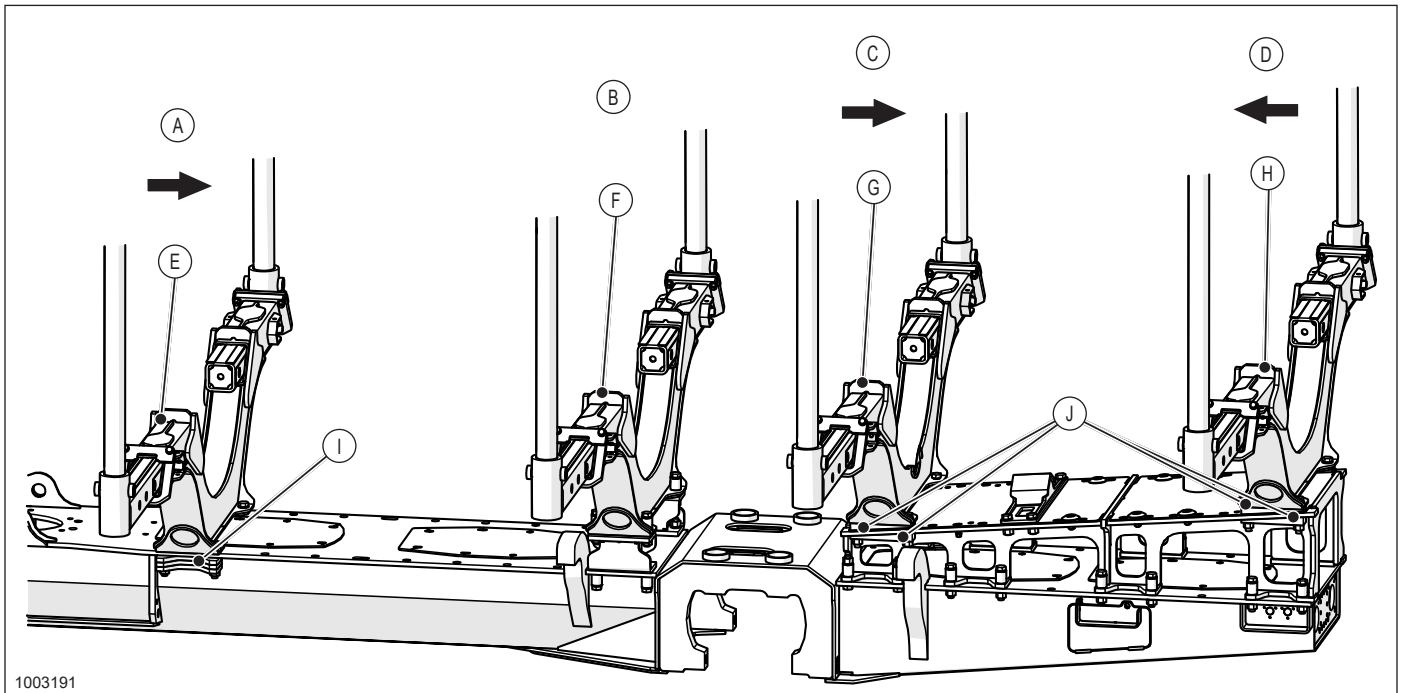

1003191

Low-Wide Ramp Version: 3160/2400

- | | |
|--|------------------|
| A Bunk #1 Can Be Moved Three Positions To The Right | F Bunk #2 |
| B Bunk #2 Must Remain In This Position | G Bunk #3 |
| C Bunk #3 Can Be Moved Multiple Positions To The Right | H Bunk #4 |
| D Bunk #4 Can Be Moved Multiple Positions To The Left | I 3/4" Spacers |
| E Bunk #1 | J Angled Spacers |

Bunk #1 can be moved three positions to the right from it's normal position shown above.

Bunk #2 must remain at the position shown.

Bunk #3 can utilize any compatible bolt pattern along the ramp up to Bunk #4.

Bunk #4 can utilize any compatible bolt pattern along the ramp up to Bunk #3.

Remove one 3/4 in. spacer from below the chassis and install it between the bunk and the chassis when moving Bunk #1 one position to the right.

Remove the angled spacers from the ramp bracket to the desired location and install with the mounting bolt when moving Bunks #3 and #4.

FIRE SUPPRESSION SYSTEM—DAFO

This information applies only if the machine is equipped with the optional Dafo fire suppression system installed by Tigercat or by an approved vendor.

Refer to the documentation provided with your machine for more information.

OVERVIEW

When the temperature sensors detect heat at 120°C (248°F), the fire suppression system will respond in 1 of 2 ways, depending on what mode the system is in. The system can also be activated manually.

AUTOMATIC MODE

An alarm sounds and the fire suppression system activates automatically when the following conditions are all true:

- the temperature sensors detect heat, and
- power is connected to the fire suppression control box

MANUAL ACTIVATION

Two methods that can be used are:

1. Manual activation button on the control panel.
2. Manual release button near the battery disconnect switch.

Power must be connected to the fire suppression system's control box for the button on the control panel to activate the system.

The manual release button does not require power to activate the fire suppression system. If, after pressing the manual activation button, the fire suppression system fails to operate, strike the manual release button.

METHOD ONE



- | | |
|---|--------------------------|
| A | Manual Activation |
| B | Fire Alarm |
| C | Faulty Release Circuit |
| D | Faulty Direction Circuit |
| E | Manual Mode |
| F | System Power |
| G | Test and Reset |

Press and hold the manual activation button on the control panel for one second. This method works only when power is connected to the fire suppression system.

ENGINE	
DIAGNOSTIC CONNECTION	3.39, 3.40
FUSE AND RELAY PANEL	3.42
HOOD	3.23
SERPENTINE BELT	3.48
ENGINE COOLANT HEATER UNIT (OPTIONAL)	3.28
COMPONENTS	3.28
CONTROLS	3.28
COOLANT HEATER AND PUMP	3.28
FUEL PUMP AND FILTER	3.28
ENGINE COOLANT HEATER UNIT PREVENTIVE MAINTENANCE	3.29
ANNUAL MAINTENANCE	3.31
BIANNUAL MAINTENANCE	3.30
DAILY MAINTENANCE	3.29
CONTROLS	3.30
ENGINE COOLANT HEATER UNIT	3.30
ENGINE COOLANT PUMP	3.30
MACHINE FUEL TANK	3.29
LOCKOUT RESET PROCEDURE	3.34
LOW VOLTAGE DISCONNECT ADJUSTMENT	3.32
MONTHLY MAINTENANCE	3.30
FILTER RESTRICTION INDICATOR	3.26
FILTERS	
AIR RECIRCULATION	3.36
DEF DOSING MODULE	3.64
DRIVE CHARGE	3.80
ENGINE FILTERS	3.74
FRESH AIR	3.36
HYDRAULIC OIL	3.77
RETURN OIL STRAINER	3.81
FIRE PREVENTION	3.9
FLUID SAMPLE COLLECTION	3.8
FORWARDER PAYLOAD CAPACITIES	3.127
FRESH AIR FILTER	3.36
FUEL SYSTEM	3.69
FUEL PUMP POWER CONNECTIONS	3.70
FUEL SHUT-OFF VALVE	3.69
FUEL TANK COMPONENTS	3.69
FUEL TANK STRAINER	3.70
ONBOARD FUEL FILL PUMP	3.69
REFUELLING	3.71
TANK CAPACITY	3.70
FUSES	
CAB FUSE PANEL	3.40
FUSE PANEL UNDER CAB	3.43
WORKLIGHTS	3.41
HOOD	
LOCKING	3.23
MAXIMUM CAPACITY	3.23
OPENING	3.23
HYDRAULIC OIL	
CHANGING	3.84
HYDRAULIC OIL SYSTEM	3.16
ADDING HYDRAULIC OIL	3.81
DRIVE CHARGE FILTER	3.80

EVERY 2 YEARS

- Replace engine coolant.
- Refer to the diesel engine service manual and attachment manual for additional required maintenance at this scheduled time period.
- Have the engine coolant heater and control unit serviced by a professional at the beginning of the heating period.

SEASONAL

- Drain and refill hydraulic oil tank with recommended hydraulic oil. Refer to APPROVED HYDRAULIC OILS in THIS SECTION.

Verify that the hydraulic oil type selected in the computer program matches the oil type being used. Adjust oil type if needed. This will allow the program to optimize the cooling and message functions to best suite the oil being used.

Hydraulic oil grade information is shown on the main menu below the hydraulic oil temperature gauge. Operating outside the recommended operating range shortens hydraulic component life.

Refer to MACHINE ADJUST SETTINGS in SECTION 2, for hydraulic oil grade selection settings information.

Refer to APPROVED HYDRAULIC OILS in THIS SECTION for hydraulic oil operating range information.

- Drain and refill cab tilt reservoir with recommended hydraulic oil. Refer to APPROVED HYDRAULIC OILS in THIS SECTION.

AS REQUIRED

- Inspect and service the engine at regular intervals as described in Engine Operation and Maintenance Manual.
- Inspect and service the fire detection and suppression equipment (if equipped) at regular intervals as described in the manufacturer's documentation.

ENGINE HOOD

OPENING THE HOOD



WARNING

Do not raise the snow blade while the hood is open. The hood may close unexpectedly.



A Engine Hood Latch, Earlier Design



A Engine Hood Latch, Later Design

Release the over centre latch on left side of the engine hood. Pull down on latch handle, lift latch ring off retainer lug on chassis.



Opening the Hood

From the platform locate the handle on side of the engine hood. Pull up on the handle and tip engine hood forward to open hood. Place the hood lock in the locked position to prevent the hood from closing while service work is being performed.

LOCKING THE HOOD



WARNING

Engage the hood lock to prevent the unintended closing of the hood.



Hood Lock

A Hood Lock in Locked Position

The hood lock on the left side (inside) of hood prevents the hood from closing when lowered into the locked position.

Release the hood lock by pushing the hood slightly in the open direction to release the pressure on the lock mechanism allowing the lock to be lifted out of the locked position (see inset picture), then reverse the above procedure to close the engine hood.



WARNING

Do not exceed the maximum capacity of the hood.

The hood can be used as a service platform to stand on only if the maximum weight on the hood does not exceed **225 kg (500 lb)**.

Refer to SECTION 1 for information.



7. Press the selection button to enter the LVD threshold page.



8. Turn the rotary knob to adjust the LVD threshold to 22 V.
9. Press the selection button three times to return to the main page and confirm the change.

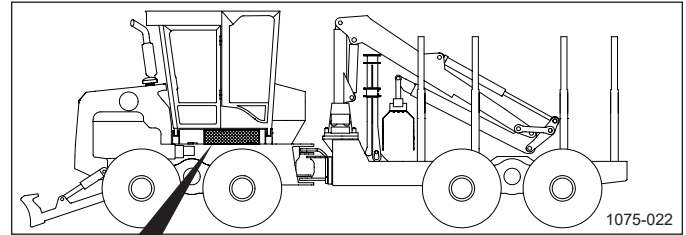

7		14		21		28	15A
6		13		20		27	15A
5	25A	12	3A	19	15A	26	
4	2A	11	20A	18	20A	25	15A
3	25A	10	30A	17	25A	24	15A
2	5A	9	20A	16	30A	23	20A
1	25A	8	20A	15	7.5A	22	20A

- | | | | |
|--------------------------|--------------------|-----------------------|--------------------------|
| 7 - SPARE | 14 - SPARE | 21 - SPARE | 28 - CLEARANCE LIGHTS |
| 6 - SPARE | 13 - SPARE | 20 - SPARE | 27 - EXTERNAL POWER PORT |
| 5 - XA2-A2-VALVE MODULE | 12 - TELEMATICS | 19 - VACUUM PUMP | 26 - SPARE |
| 4 - FUEL LEVEL SENSOR | 11 - DEF LINES | 18 - A/C COMP. CLUTCH | 25 - FUEL HEATER 2 |
| 3 - XA2-A1 VALVE MODULE | 10 - ENGINE ECU | 17 - CAB COMPUTERS | 24 - FUEL HEATER 1 |
| 2 - ENGINE BUSBAR | 9 - COOLANT HEATER | 16 - LIFT PUMP | 23 - EXHAUST FLAP |
| 1 - XA2-A0 ENGINE MODULE | 8 - HVAC | 15 - DASA SYSTEM | 22 - ATS SENSORS |

55144AENG R1

Fuse Panel in Electrical Box—Under Cab, Later Design

***NOTE:** The aftertreatment system and its related components are applicable to Tier 4f machines only.

The DOC/SCR aftertreatment system is electronically managed by the DENOX 2.2 system incorporated into the engine electronic control unit (ECU). The ECU calculates and adjusts the flow rate of the DEF solution into the system based on current engine speed, torque delivered, exhaust temperature, amount of nitrogen oxides and ammonia present.

The exhaust passes through the diesel DOC which uses oxidation at high temperatures to convert carbon monoxide (CO), hydrocarbons (HC) and the soluble organic fraction (SOF) of diesel particulates into inert compounds, carbon dioxide (CO₂) and water vapour (H₂O). It also converts nitrogen oxide (NO) into nitrogen dioxide (NO₂) which enhances the performance of the SCR catalyst.

The supply module pump picks up the DEF solution from the tank and sends it under pressure through the dosing module filter to the dosing module (DEF injector) to be injected into the exhaust at the outlet of the DOC and pass through the mixer tube upstream of the catalytic converter.

The first phase of the SCR process takes place in the first part of the catalytic converter: high temperature exhaust gas evaporates the DEF solution instantly and, by hydrolysis, converts it into ammonia (2NH₃) and carbon dioxide (CO₂).

Evaporation of the solution lowers exhaust gas temperature, bringing it closer to the optimum temperature required by the process.

The exhaust fumes and ammonia at the proper reaction temperature, are introduced into the catalytic converter, where the second phase of the process takes place: by reacting with the oxygen in the exhaust gases the ammonia is converted into free nitrogen (N₂) and water vapour (H₂O).

Finally the high efficiency catalytic converter incorporates a clean up catalyst (CUC) which reduces any excess ammonia (NH₃) which may result from the SCR process.

NOTICE

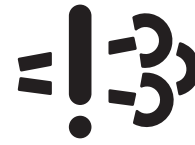

- DO NOT IDLE THIS ENGINE FOR MORE THAN 1 HOUR.
- ALLOW ENGINE TO RUN AT LOW IDLE FOR 3 TO 5 MINUTES BEFORE OPERATING AT HIGH IDLE OR SHUTTING ENGINE OFF.
- DAMAGE TO EMISSION CONTROL SYSTEM WILL RESULT.

63281BENG R2

IMPORTANT !

Do not idle the engine longer than **1 hour**. Damage to the emission control system will result. When this machine idles for an extended period excess hydrocarbon buildup is created in the DOC/SCR aftertreatment system. Burn off of excess hydrocarbon at full load immediately after a long idle period will generate excess heat which will cause damage to emission control system components.



8. To remove the tank, remove four bolts and lift the tank and steel frame out of the engine compartment.
9. Clean the inside of the tank with clean DEF, distilled or demineralized water. Thoroughly drain the tank after cleaning.

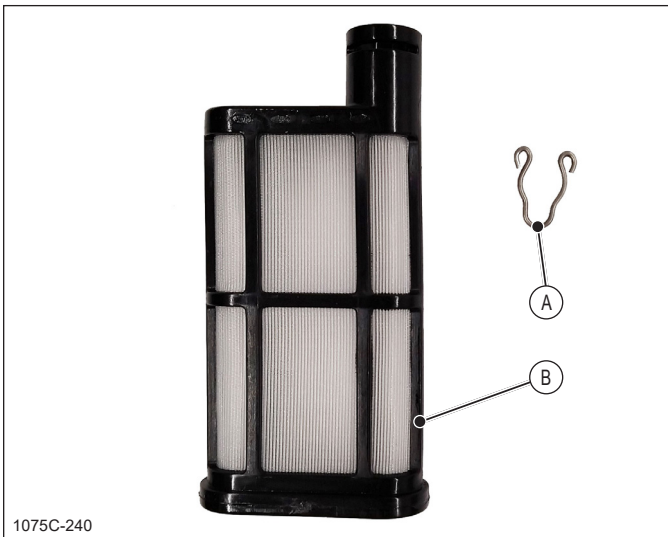

1075C-240
 A Clip
 B Strainer

10. Remove the clip that secures the strainer and remove the strainer from the sending unit.
11. Clean the strainer with clean DEF, distilled or demineralized water.
12. Install the strainer.
13. Remove the strainer and clean it with clean DEF, distilled or demineralized water.
 Refer to **CLEANING THE DEF FILL STRAINER** in THIS SECTION.
14. Install the quality sensor.
 Tighten and then torque the bolts.
 Bolts: M6
 Torque: 2.5 - 3.5 Nm (1.8 - 3.5 lbf-ft)
15. Install the sending unit and the fill strainer.

16. Reconnect the hoses and electrical connector to the sending unit.

Do not reuse the DEF that has been drained from the tank. Use a licensed waste disposal contractor or as otherwise required by local laws to dispose of DEF.

If any DEF fluid has spilled, rinse well with water.

FUEL FILTER/WATER SEPARATOR AND ENGINE FUEL FILTER

IMPORTANT!

Failure to service and replace filters at the proper intervals specified in the manufacturer's manuals, could cause damage to the machine and result in the product warranty becoming NULL and VOID. Check Tigercat parts catalog for replacement filters.

IMPORTANT!

Filters that are an integral part of the engine (fuel and lubricating oil) must be serviced and replaced according to the ENGINE MANUFACTURER'S OPERATION AND MAINTENANCE MANUAL.

The engine fuel injection system requires extremely clean fuel. To accomplish this, the engines typically use filters with a finer micron rating.

If the fuel supply is dirty, the fuel filter must be replaced more frequently than recommended in the owner's manual. It is also recommended that the fuel/water separator bowl be drained daily. Operating the machine with a clogged fuel filter will result in low engine power and severe fuel injection system damage.

NOTICE



Tigercat does not recommend the pre-filling of spin-on filters due to the risk of damage to the fuel system caused by unfiltered fuel. Unfiltered fuel used to pre-fill filters enters directly into the fuel circuit. Contaminants in unfiltered fuel can cause significant and costly damage to fuel system components. The cleanliness of fuel cannot be guaranteed unless it is pre-filtered before use.

Use of filters other than genuine Tigercat replacement filters is not recommended. Replace filters at the recommended time intervals. Refer to scheduled maintenance in this section.

To prolong the operating life of the fuel filter, maintain a clean fuel supply storage tank that is free of water, and pre-filter the fuel prior to filling the tank.

⚠ WARNING

The fuel pump high-pressure fuel lines and fuel rail contain very high pressure fuel. Never loosen any fittings while the engine is running. Personal injury and property damage can result.

DRAINING THE HYDRAULIC OIL TANK

1. Prepare the machine as described in PREPARING THE MACHINE FOR MAINTENANCE in SECTION 1.
2. Tilt the cab.
Refer to TILTING THE CAB in THIS SECTION.



1003001

A Quick Disconnect
B Drain Valve

3. Clean the area around the quick disconnect to prevent impurities from entering the system.
 - Connect the drain/fill hose to the quick disconnect on the drain line.
4. If desired, allow air to enter the tank as the oil is being drained:



1003230

A Access Cover

- a. Remove the access cover from the top of the hydraulic oil tank.

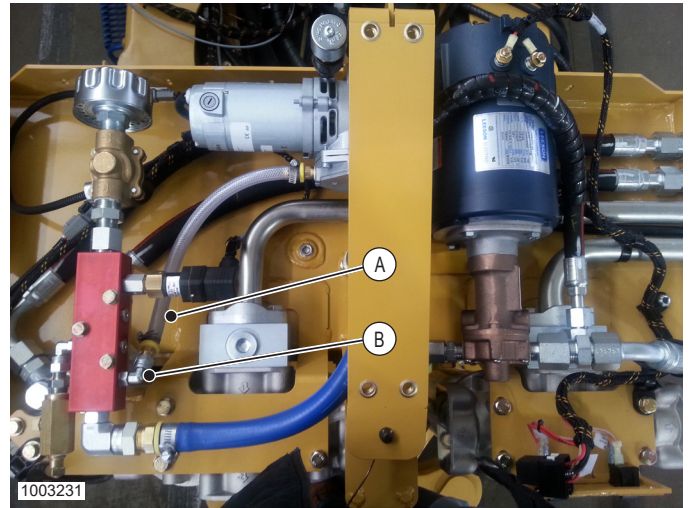

1003231

A Hose
B Fitting

- b. Remove the clear hose from the fitting shown, or loosen the fitting.
5. Open the drain valve.
6. Drain the oil into a suitable container.
Tank capacity = 128 L (34 US gallons).
7. Close the drain valve.
8. Remove the drain/fill hose.
9. Attach the clear hose or tighten the fitting.
10. Secure the access cover to the top of the tank.
11. Fill the hydraulic oil tank.
Refer to ADDING HYDRAULIC OIL in THIS SECTION.

BOGIE SLEW BEARING INSPECTION

Inspect the bogie slew bearings for leaks and for wear.

1. While on flat and level ground, drive the machine straight (not articulated) back and forth a few times to settle the slew bearings.
2. Prepare the machine as described in PREPARING THE MACHINE FOR MAINTENANCE in SECTION 1.
3. Inspect the area around the slew bearings for oil leaks and for contact between the slew ring and chassis. If oil leaks or contact is observed, the slew bearing must be replaced immediately.

6. Replace the slew bearing as soon as possible if:
 - a. The top or bottom measurement is less than 0.5 mm (0.02 in.), or
 - b. The difference between the 2 measurements is greater than 1.25 mm (0.05 in.).

If the machine is put back into service before a new bearing is installed, measure the gap regularly to detect any rapid decrease of the remaining gap.

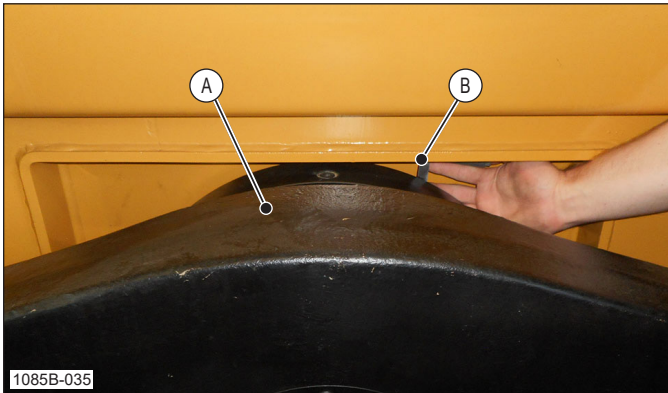

A Top of Bogie
B Feeler Gauge

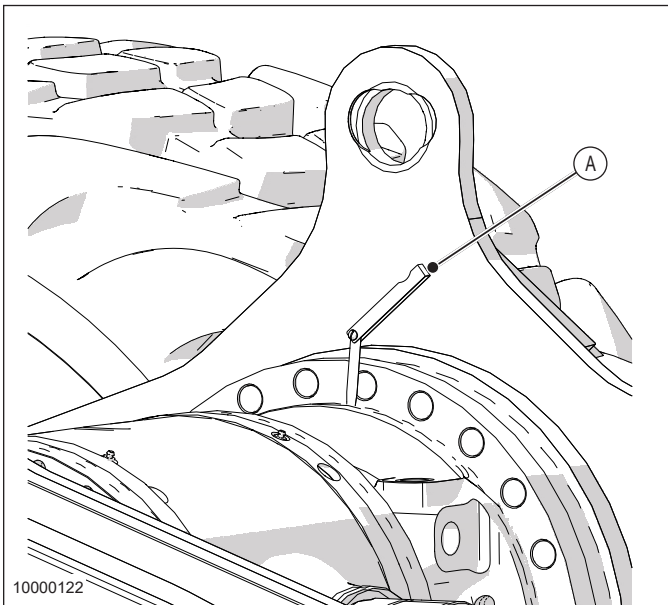

A Feeler Gauge

4. Use a feeler gauge to measure the gap between the top of the slew bearing and the chassis. Measure as close to the top as possible.
5. Use a feeler gauge to measure the gap between to bottom of the slew bearing and the chassis.

**TIGERCAT CRANE
TELESCOPIC BOOM PLAY**

Check the vertical and horizontal play of the telescopic boom as part of scheduled maintenance every 250 hours. Wear of the boom guides will result in an increased amount of play horizontally and vertically when operating the telescopic boom.

The boom guides at the front and rear of the telescopic boom wear during normal use and require adjustment. Cranes that are frequently overloaded or used in extreme conditions will wear faster. Lack of regular greasing will also result in faster wear.

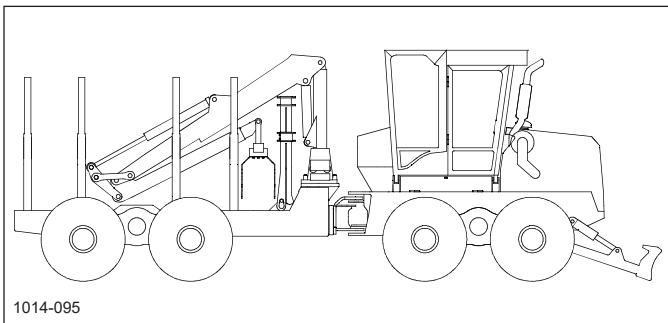

Crane in Park Position

BOOM GUIDES - BASE END

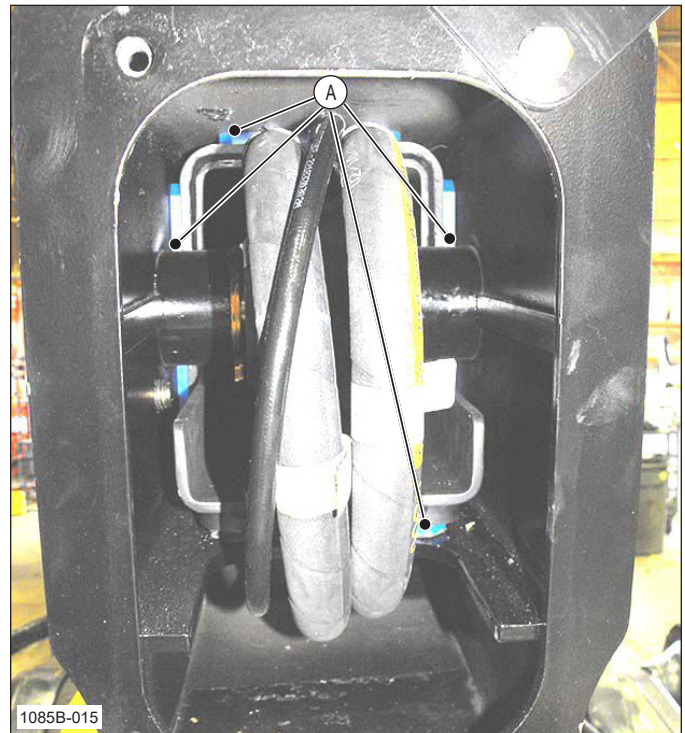

A Boom Guide

1. Check the boom guides at the base end by removing the cover at the base end of the stick boom and visually inspecting them for wear. Boom guides must be adjusted or replaced before they wear down to a minimum thickness of 2 mm beyond the bracket.

Adjustment or replacement of the base end boom guides requires disassembly of the telescopic boom. For this reason it is recommended that base end boom guides be inspected and replaced if required whenever major maintenance is performed on the telescopic boom. If the boom guides are only slightly worn they can be adjusted by adding shims. Do not add too many shims under the boom guides as this will push them too far out of the brackets holding them in place and may cause them to dislodge.

4. If the bolt will thread into the shaft, then the transmission is in 1st gear. Skip to step 8. If the bolt will NOT thread into the shaft, the transmission is likely in 2nd gear and must be put in 1st gear as follows:



5. Thread the bolt (without the spacer and cap) into the shaft.
6. Pull the bolt out to move the shaft out and put the transmission in 1st gear.
7. Reinstall the bolt and spacer into the cap and thread it into the transmission shaft.

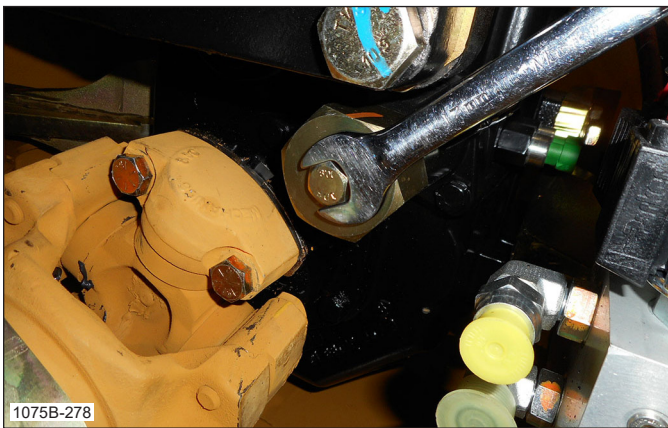

8. Tighten the bolt to disconnect the transmission from the drive wheels.

PREPARING THE STEERING CYLINDERS

To enable machine steering if the engine cannot be run while being towed, cross connect the hydraulic hoses as shown:

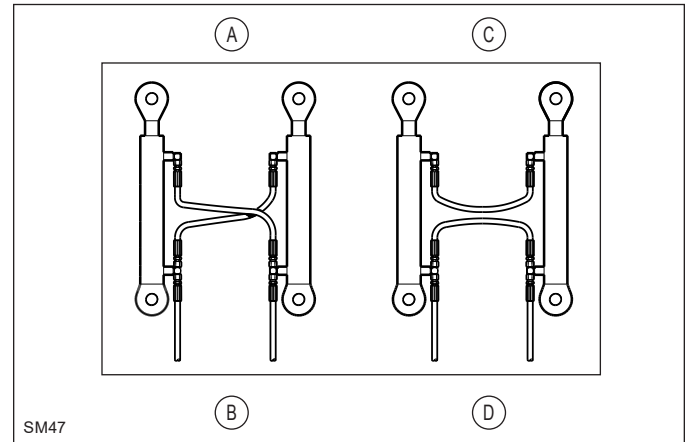

- A Steering Cylinders
- B Normal Hose Connections
- C Steering Cylinders
- D Hoses on One Cylinder Cross Connected for Towing

Cross connect the hydraulic hoses on one of the steering cylinders, as shown, to enable trapped oil to flow freely between the two steering cylinders. This enables the machine to turn and provides some damping effect.

Parker

JIC 37 Degree Flare			
SAE Dash Size	Thread Size	Tube Connection FFWR	Swivel or Hose Connection FFWR
-2	5/16-24	NA	NA
-3	3/8-24	NA	NA
-4	7/16-20	2	2
-5	1/2-20	2	2
-6	9/16-18	1 1/2	1 1/4
-8	3/4-16	1 1/2	1
-10	7/8-14	1 1/2	1
-12	1 1/16-12	1 1/4	1
-14	1 3/16-12	1	1
-16	1 5/16-12	1	1
-20	1 5/8-12	1	1
-24	1 7/8-12	1	1
-32	2 1/2-12	1	1
-40	3-12	1	1

NPTF			
SAE Dash Size	Thread Size	Tube Connection TFFT	Swivel or Hose Connection TFFT
-2	1/8-27	2-3	2-3
-3	NA	NA	NA
-4	1/4-18	2-3	2-3
-5	NA	NA	NA
-6	3/8-18	2-3	2-3
-8	1/2-14	2-3	2-3
-10	7/8-14	NA	NA
-12	3/4-14	2-3	2-3
-14	NA	NA	NA
-16	1-11 1/2	1.5-2.5	1.5-2.5
-20	1 1/4-11 1/2	1.5-2.5	1.5-2.5
-24	1 1/2-11 1/2	1.5-2.5	1.5-2.5
-32	2-11 1/2	1.5-2.5	1.5-2.5
-40	NA	NA	NA

F.F.W.R : Flats From Wrench Resistance
All values are for Steel, Stainless Steel and Brass

T.F.F.T. : Turns from finger tight
All pipe values are for Steel, Stainless Steel and Brass

O'ring Face Seal / Seal-Lok			
SAE Dash Size	Thread Size	Tube Connection FFWR	Swivel or Hose Connection FFWR
-2	NA	NA	NA
-3	NA	NA	NA
-4	9/16-18	1/4 TO 1/2	1/2 TO 3/4
-5	NA	NA	NA
-6	11/16-16	1/4 TO 1/2	1/2 TO 3/4
-8	13/16-16	1/4 TO 1/2	1/2 TO 3/4
-10	1-14	1/4 TO 1/2	1/2 TO 3/4
-12	1 3/16-12	1/4 TO 1/2	1/3 TO 1/2
-14	NA	NA	NA
-16	1 7/16-12	1/4 TO 1/2	1/3 TO 1/2
-20	1 11/16-12	1/4 TO 1/2	1/3 TO 1/2
-24	2-12	1/4 TO 1/2	1/3 TO 1/2
-32	NA	NA	NA
-40	NA	NA	NA

BSPT			
SAE Dash Size	Thread Size	Tube Connection TFFT	Swivel or Hose Connection TFFT
-2	1/8-28	2-3	2-3
-3	NA	NA	NA
-4	1/4-19	2-3	2-3
-5	NA	NA	NA
-6	3/8-19	2-3	2-3
-8	1/2-14	2-3	2-3
-10	NA	NA	NA
-12	3/4-14	2-3	2-3
-14	NA	NA	NA
-16	1-11	1.5-2.5	1.5-2.5
-20	1 1/4-11	1.5-2.5	1.5-2.5
-24	1 1/2-11	1.5-2.5	1.5-2.5
-32	2-11	1.5-2.5	1.5-2.5
-40	NA	NA	NA

F.F.W.R : Flats From Wrench Resistance
All values are for Steel, Stainless Steel and Brass

T.F.F.T. : Turns from finger tight
All pipe values are for Steel, Stainless Steel and Brass

SAE J1926 Straight Thread Port Assembly Torques

SAE DASH SIZE	THREAD SIZE	ASSEMBLY TORQUE = 10 % -0											
		NON-ADJUSTABLE				ADJUSTABLE				PLUGS			
		SEAL-LOK		TRIPLE-LOK FERULOK PIPE FITTINGS		SEAL-LOK		TRIPLE-LOK FERULOK PIPE FITTINGS		HOLLOW HEX HP50N-S		HEX HEAD P50N-S	
		lbf.ft (lbf.in)	Nm	lbf.ft (lbf.in)	Nm	lbf.ft (lbf.in)	Nm	lbf.ft (lbf.in)	Nm	lbf.ft (lbf.in)	Nm	lbf.ft (lbf.in)	Nm
2	5/16-24	(310)	20	(85)	10	(310)	20	(60)	7	(30)	3.5	(85)	10
3	3/8-24	(310)	20	(155)	18	(310)	20	(100)	11	(55)	6	(155)	18
4	7/16-20	(310)	20	(260)	29	(310)	20	(180)	20	(120)	13.5	(260)	29
5	1/2-20	(360)	40	(280)	32	(360)	40	(250)	28	(170)	19	(280)	32
6	9/16-18	(420)	46	(350)	40	(420)	46	(350)	40	(410)	46	(350)	40
8	3/4-16	60	80	(620)	70	60	80	(620)	70	60	80	(620)	70
10	7/8-14	100	135	85	115	100	135	85	115	100	135	85	115
12	1 1/16-12	135	185	135	183	135	185	135	183	135	185	135	183
14	1 3/16-12	175	235	175	237	175	235	175	237	175	235	175	237
16	1 5/16-12	200	270	200	271	200	270	200	271	200	270	200	271
20	1 5/8-12	250	340	250	339	250	340	250	339	250	340	250	339
24	1 7/8-12	305	415	305	414	305	415	305	414	305	415	305	414
32	2 1/2-12	375	510	375	509	375	510	375	509	375	510	375	509

CLICK HERE TO **DOWNLOAD** THE COMPLETE MANUAL

- Thank you very much for reading the preview of the manual.
- You can download the complete manual from: www.heydownloads.com by clicking the link below



- Please note: If there is no response to CLICKING the link, please download this PDF first and then click on it.

CLICK HERE TO **DOWNLOAD** THE COMPLETE MANUAL