

SQUARE SHOOTER

OPERATOR'S MANUAL

SS-624

SS-636

SS-836

SS-842

SS-1048

 **TEREX HANDLERS**

455 N. Superior Ave.
Baraga, MI 49908-0248
Ph. (906) 353-6675 Fax (906) 353-7543
<http://www.sqshooter.com>
E-mail: bpi@up.net

CLICK HERE TO **DOWNLOAD** THE COMPLETE MANUAL

- Thank you very much for reading the preview of the manual.
- You can download the complete manual from: www.heydownloads.com by clicking the link below



- Please note: If there is no response to CLICKING the link, please download this PDF first and then click on it.

CLICK HERE TO **DOWNLOAD** THE COMPLETE MANUAL

GENERAL SAFETY

GENERAL SAFETY PROCEDURES

AVOID ELECTRICAL POWER LINES



DANGER

REQUIRED CLEARANCE FOR NORMAL VOLTAGE IN OPERATION NEAR HIGH VOLTAGE POWER LINE AND OPERATION IN TRANSIT WITH NO LOAD AND BOOM OR MAST LOWERED.

Normal Voltage, kV Required (Phase to Phase) (m)	Minimum Clearance, ft.
Operation Near High Voltage Power Lines	
to 50	10 (3.05)
Over 50 to 200	15 (4.60)
Over 200 to 350	20 (6.10)
Over 350 to 500	25 (7.62)
Over 500 to 750	35 (10.67)
Over 750 to 1000	45 (13.72)
Operation in Transit With No Load and Boom Lowered	
to 0.75	4 (1.22)
Over 0.75 to 50	6 (1.83)
Over 50 to 345	10 (3.05)
Over 345 to 750	16 (4.87)
Over 750 to 1000	20 (6.10)



WARNING

Always remain completely inside cab enclosure while operating the machine.

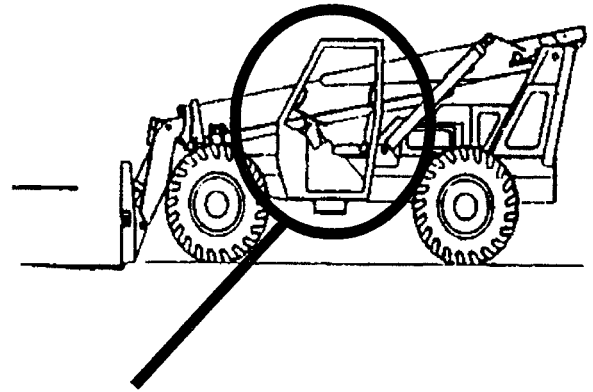

WARNING

Never operate this machine under the influence of drugs, alcohol and/or medication which can cause drowsiness.



WARNING

Never transport or lift personnel into position with this forklift. It is not designed as a personnel lifting device.

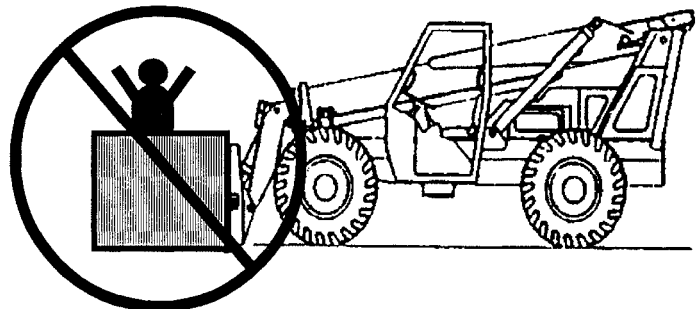

CONTROLS AND INSTRUMENTS

DASH PANEL

WARNING

Always ensure that machine level indicator is at zero (O) before raising the boom. Raising boom with a unlevel machine may cause the machine to overturn, resulting in injury or death.

WARNING

Use frame sway control to level machine only when the boom position is horizontal or lower. Using frame sway control when boom is higher than a horizontal position may cause machine to overturn, resulting in injury or death.

1. FRAME SWAY CONTROL

The frame sway control (E) is located on the dash panel. The frame sway control is used in conjunction with the machine level indicator (F) mounted on top of the dash panel. The sway control lever is either moved to the left or right depending on the particular requirement.

2. ROTATING FORK FRAME CONTROL

The rotating fork frame control (G) located on the dash panel allows the operator to position forks for insertion or removal from pallet.

NOTE: The rotating fork frame is an option. If your machine is not equipped with a rotating fork frame, no control will be mounted on the dash panel.

3. HEADLIGHT SWITCH

The head light switch (H) is located on the dash panel. This is a push/pull type switch.

NOTE: Head lights are optional. If your machine is not equipped with headlights, no switch will be mounted on the dash panel.

3. PUMP DESTROKE CONTROL

The pump destroke button (J) is located on the dash panel.

4. FRONT STABILIZER CONTROL

The front stabilizer switches (K) are located on the dash panel just to the left of the frame sway control switch.

NOTE: The front stabilizer switches are standard equipment on the SS-1048.

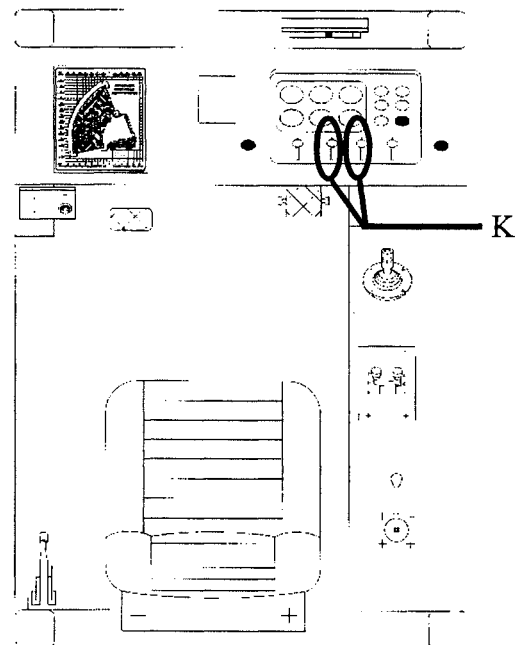
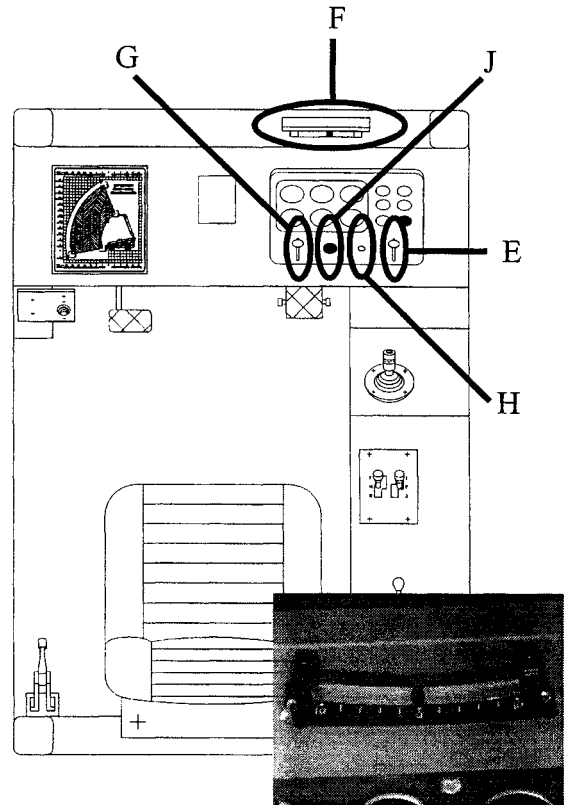

OPERATION

BEFORE STARTING THE ENGINE



WARNING

Do not check coolant level if engine has recently been run. Injury may occur from hot escaping pressurized coolant.

3. With engine cool, check engine coolant level.

When checking coolant level, coolant should be visible in top tank of radiator. If coolant is not visible add a 50/50 mixture of water and glycol- based anti freeze/coolant.

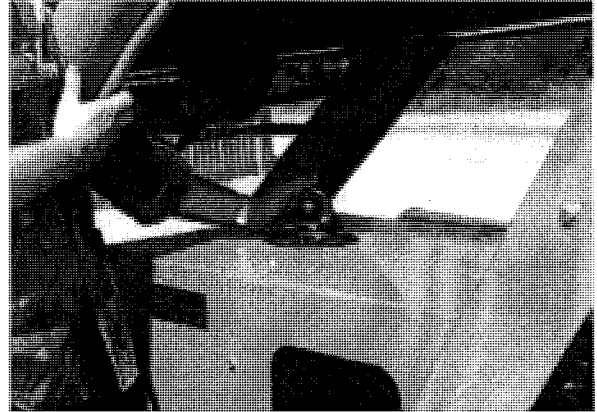

OPERATION

TRANSPORTING A LOAD

 **WARNING**

Any SS-1048 SQUARE SHOOTER[®] equipped with Quick Attach option using a fork carriage **MUST** have a fork tine pin with a 2 1/4 INCH DIAMETER. Forks **MUST** also have a 5000 LB capacity each and be stamped accordingly. Failure to follow these specifications could result in serious injury or death.

 **WARNING**

Transporting a load with the boom above horizontal could cause a roll over hazard.

The forks should be tipped back slightly, and kept as low to the ground as load will allow without raising the boom above horizontal position.

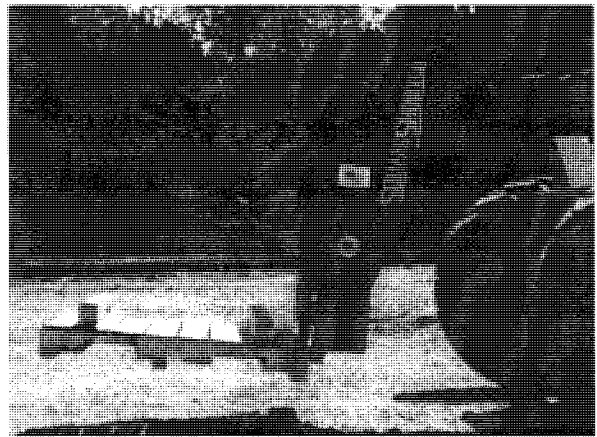

 **WARNING**

At no time should any load be suspended from forks by use of chains, ropes, straps etc. If a load must be suspended the use of a truss (jib) boom is mandatory.

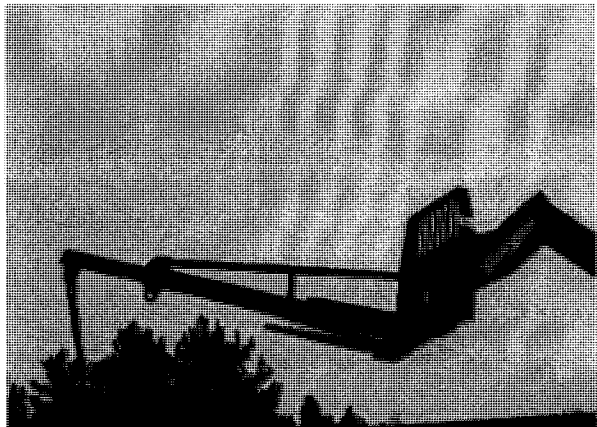

SECTION 4

MAINTENANCE PROCEDURES

MAINTENANCE PROCEDURES

WEEKLY (OR 50 HOURS) MAINTENANCE

DANGER

SQUARE SHOOTER[®] FORKLIFTS ARE BALLASTED WITH WEIGHTED TIRES. LOSS OF BALLAST CAN EFFECT MACHINE STABILITY AND CAN CAUSE A ROLL OVER HAZARD RESULTING IN DAMAGE, INJURY OR DEATH

8. Check tires for chloride and inflation pressure.

- A. With valve stem at its highest point, push deflator point of valve core for about a full second. There should be a solid stream of chloride solution and no air. If air is present, tire is under-filled with chloride solution. Replace the lost chloride solution to a level of one inch above the steel wheel. Also if steel wheel is not kept submerged in chloride solution, it will rust causing early failure. Proper chloride solution is 150 lbs. of calcium chloride to 50 gallons of water.

NOTE: The SS-624 is the only SQUARE SHOOTER tractor without weighted tires.

- B. Use only a corrosion proof tire gauge to check tire pressure. Tires should be inflated to 55 PSI.

MAINTENANCE PROCEDURES

SIX MONTH (OR 1,000 HOURS) MAINTENANCE

ADJUSTING EXTENSION-RETRACTION CHAINS, SS-836

CHECK POINTS: Proper adjustment can be checked with a tape measure. Extend boom fully, then retract about one inch. On either side of middle section estimate center. Place one end of tape measure on bottom surface of boom directly below estimated center.

TOLERANCE: Distance from bottom surface of boom to lowest part of both extension chains should be no more than 4 inches.

FIRST ADJUSTMENT: If the tolerance is more than 4 inches, go to the underside front of the large boom tube to the two extension chain anchors.

A. Tighten an adjustable wrench across the flat part of the chain.

B. Using a 1-7/16 inch wrench tighten the nut until the 4 inch tolerance is achieved. Repeat the procedure on the other chain.

NOTE: Both chains on the SS-836 are located on the bottom of the large section, and should have the same measurement.



SECOND ADJUSTMENT: If the measurement is still more than 4 inches, you will have to adjust the compression spring. This spring is located on the front top area of the large boom tube. The gap between the majority of the spring coils should be no less than .030. Measure gap with a feeler gauge. To collapse the coils down to .030 gap, place a 1-7/16 inch wrench on both nuts on the adjuster shaft and tighten until coil gap is correct.

CLICK HERE TO **DOWNLOAD** THE COMPLETE MANUAL

- Thank you very much for reading the preview of the manual.
- You can download the complete manual from: www.heydownloads.com by clicking the link below



- Please note: If there is no response to CLICKING the link, please download this PDF first and then click on it.

CLICK HERE TO **DOWNLOAD** THE COMPLETE MANUAL