

TEREX

HANDLERS

OPERATOR'S MANUAL

TH644C

TH842C

TH844C

 **TEREX HANDLERS**

455 N. Superior Ave.

Baraga, MI 49908-0790

Ph. (906) 353-6675 Fax (906) 353-7543

<http://www.terexlift.com>

CLICK HERE TO **DOWNLOAD** THE COMPLETE MANUAL

- Thank you very much for reading the preview of the manual.
- You can download the complete manual from: www.heydownloads.com by clicking the link below



- Please note: If there is no response to CLICKING the link, please download this PDF first and then click on it.

CLICK HERE TO **DOWNLOAD** THE COMPLETE MANUAL

ROUGH TERRAIN FORK LIFT SAFETY

MANAGEMENT'S RESPONSIBILITIES

1. Ensure operators are competent, physically fit, trained and if required licensed.
2. Have a supervisor at the job site to be responsible for job safety.
3. Crew members given specific safety responsibilities and instructed to report any unsafe conditions to the supervisor.
4. Supply the weight on the load to be lifted to the operator.
5. Verify that all crewmembers are familiar with OSHA, ANSI B56.6 requirements as well as instructions in the manuals.



GENERAL SAFETY



GENERAL SAFETY PROCEDURES

HYDRAULIC SAFETY



WARNING

Hot hydraulic oil can cause severe burns. **DO NOT** work on the hydraulic system if the oil temperature exceeds 120 degrees F. (49 degrees C).

Before **ANYONE** works on the hydraulic system:

1. Lower the boom to the horizontal position.
2. Support the boom to avoid unintentional lowering.
3. Shutdown the engine.
4. Remove the key from the ignition.
5. Clean the area around the oil reservoir cap (A).

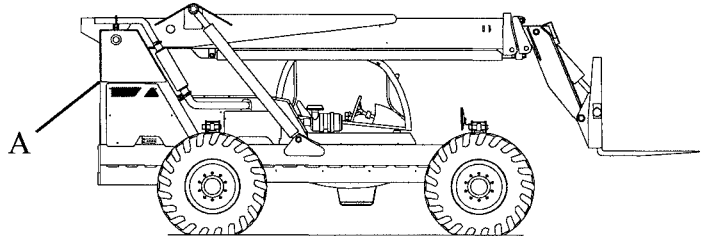

FLUIDS UNDER PRESSURE



WARNING

Escaping fluid under pressure can penetrate the skin and can cause serious personal injury.

Use a piece of cardboard or paper to search for leaks. **DO NOT** use hands. Before disconnecting hydraulic lines, be sure to relieve all line pressure. Before applying pressure to the system, be sure that all connections are tight. **DO NOT** apply pressure to a damaged line, hose or fitting.

If injured by escaping fluid, see a doctor at once. Proper medical treatment must be administered immediately. A serious infection or reaction can result without proper medical treatment.

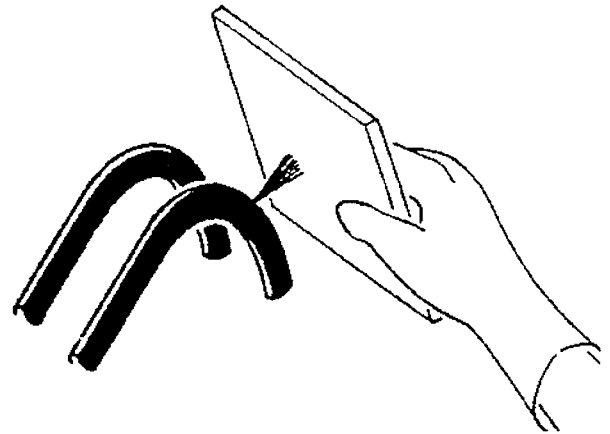

SERVICE TIRES SAFELY



WARNING

An improperly mounted over-pressurized tire can result in tire explosion causing possible personal injury. An inflation cage or other safety device must be used during tire inflation.

DO NOT attempt to mount a tire unless you have the proper equipment and experience to perform the job. If you do not have the proper qualifications to perform the job have your dealer or qualified repair service perform the repair.

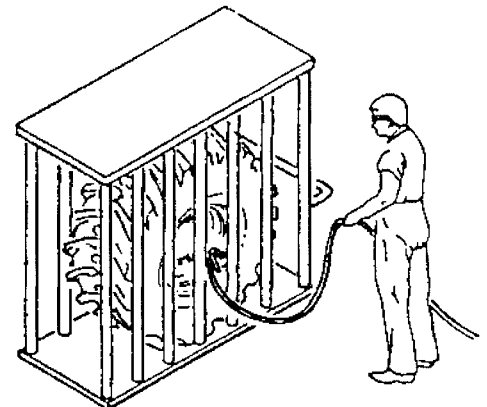

CONTROLS AND INSTRUMENTS

OPERATOR'S COMPARTMENT

- | | | | |
|-------------------------------|----------------------------|--------------------------|---------------------------------|
| 1. Accelerator Pedal | 8. Hourmeter | 15. Parking Brake Switch | 22. Heater Switch |
| 2. Joystick 4-way Controller | 9. Gauges | 16. Pump Off Button | 23. Plug / Turn Signal Wires |
| 3. Transmission Control Lever | 10. Machine Level Gauge | 17. Front Wiper Switch | 24. Interior Rear View Mirror |
| 4. Steering Selector | 11. Plug / 12 Volt Access. | 18. Ignition Switch | 25. Frt. Axle Differential Lock |
| 5. Service Brake Pedal | 12. Seat | 19. Auxiliary Hydraulics | 26. Low Brake Press. Light |
| 6. Rear Wiper Switch | 13. Frame Level Switch | 20. Steering Wheel | 27. Work Lights Switch |
| 7. Load Chart | 14. Seat Belt | 21. Headlight Switch | |

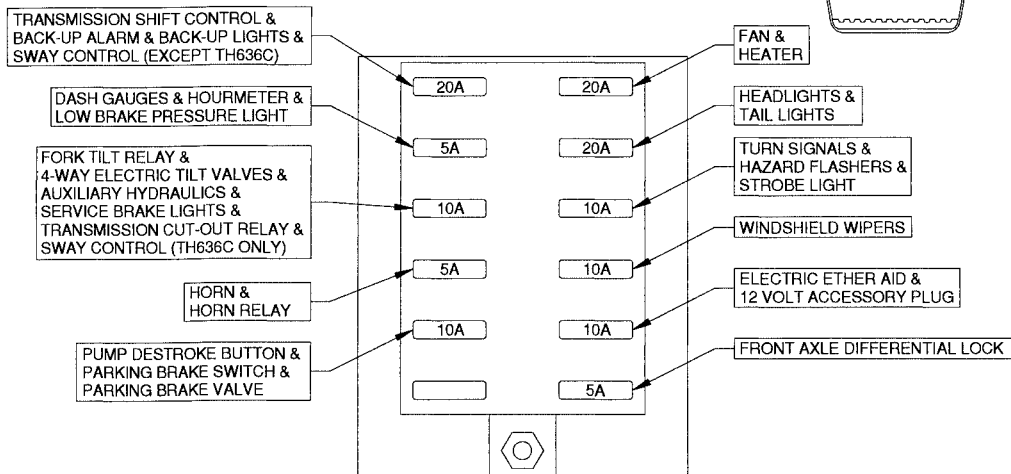
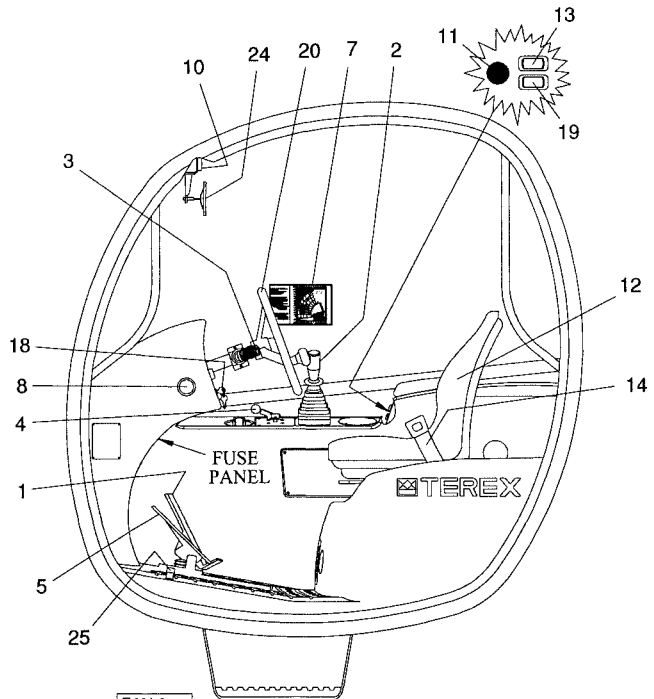
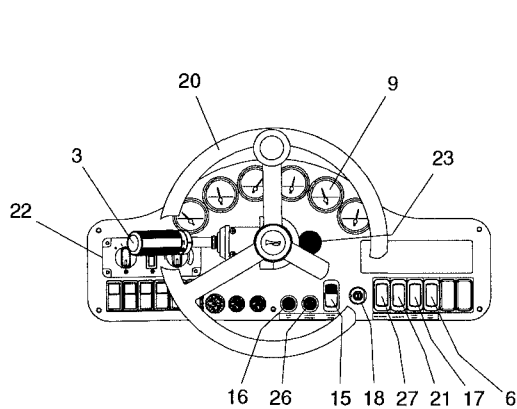

FUSE PANEL VIEW

SECTION 4
OPERATION

OPERATION

BEFORE OPERATING THE FORKLIFT

CAUTION

If any gauge reading does not fall within the set tolerances the machine must be repaired before operation.

Check the dash mounted gauges for logical readings.

- | | |
|----------------------------------|----------------|
| (1) Fuel Level | 1/2 to Full |
| (2) Engine Water Temperature | 180°F to 200°F |
| (3) Engine Oil Pressure | 40 to 80 PSI |
| (4) Transmission Oil Temperature | 180°F to 200°F |
| (5) Transmission Oil Pressure | 240 to 280 PSI |
| (6) Voltmeter | 12 to 14 Volts |

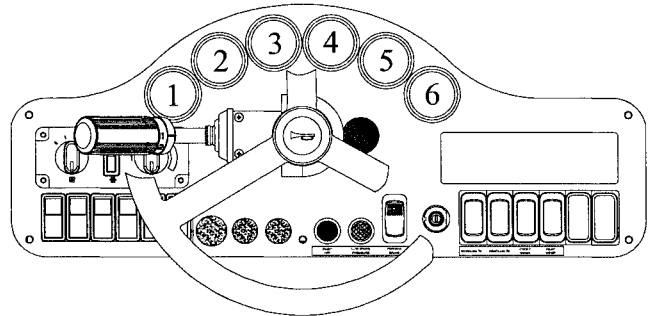

Operate the joystick controller momentarily in all directions.

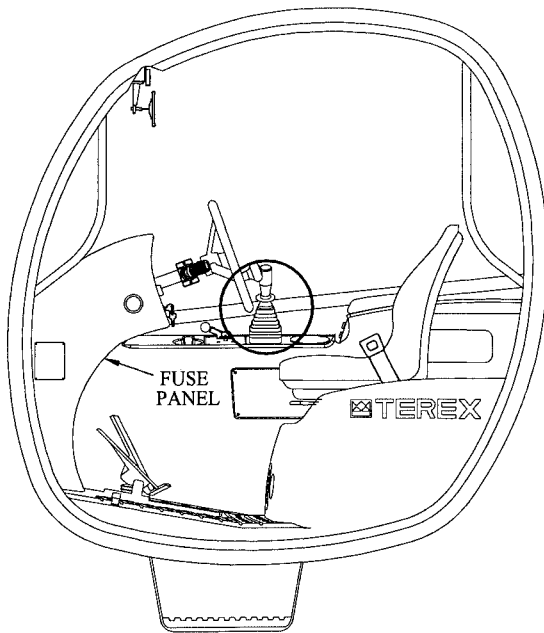

STANDARD JOYSTICK FUNCTIONS

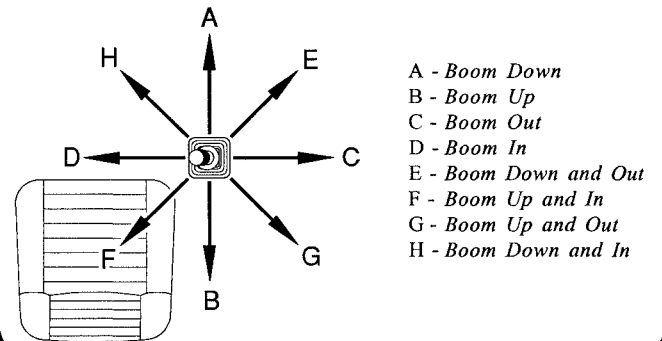

BUTTON DEPRESSED FUNCTIONS

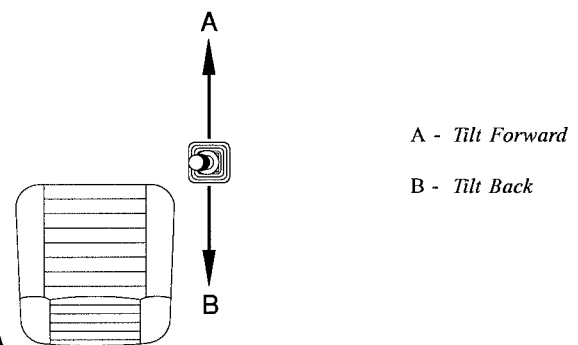

SECTION 5

MAINTENANCE PROCEDURES

MAINTENANCE PROCEDURES

DAILY MAINTENANCE

CHECK TIRE FOR PROPER INFLATION

Location: Wheel ends.

To Check: With the valve stem (C) positioned to the top of the tire, check the tire pressure with the tire cold and a properly functioning air pressure gauge.

Setting: 50 PSI.

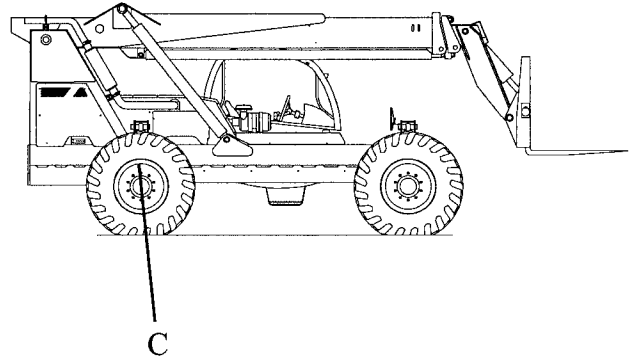

DANGER

All tires require a calcium chloride ballast or an optional foam fill to be operated safely. The loss of ballast can affect the machine's stability and cause a rollover hazard, resulting in damage, injury or death.

INSPECT AIR CLEANER

Location: Air cleaner assembly.

To Check: Remove the rear of the canister, remove the filter elements.

Guideline: Inspect the filter elements for contamination. Inspect the tubing going to the filter body from the engine for cracks or leaks. Inspect the air cleaner body and gaskets for cracks or leaks.

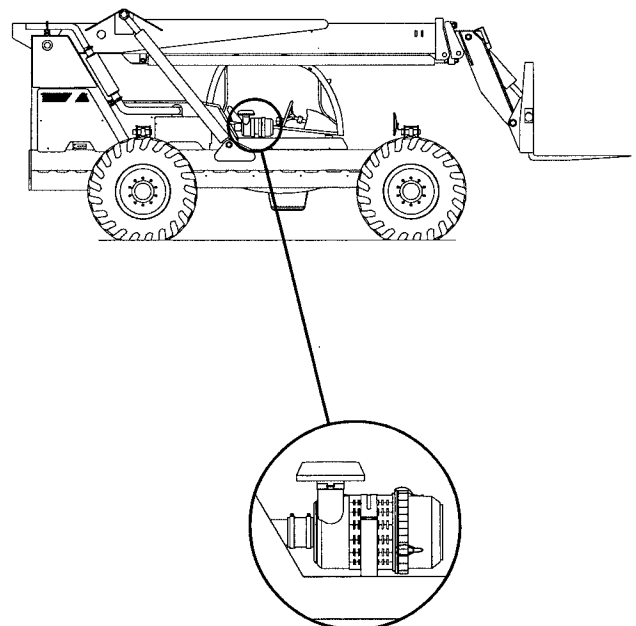

WARNING

Due to various operating conditions, the air cleaner's elements should be changed as the environment requires.

MAINTENANCE PROCEDURES

1000 HOUR MAINTENANCE

Perform "BEFORE SERVICING PROCEDURES" before attempting any of the following checks.

Complete all "DAILY MAINTENANCE" checks prior to this time interval.

Complete all "50 HOUR MAINTENANCE" checks prior to this time interval.

Complete all "100 HOUR MAINTENANCE" checks prior to this time interval.

Complete all "250 HOUR MAINTENANCE" checks prior to this time interval.

Complete all "500 HOUR MAINTENANCE" checks prior to this time interval.

Complete all "750 HOUR MAINTENANCE" checks prior to this time interval.

Perform "BEFORE OPERATING CHECKS" before attempting any of the following checks.

MANUFACTURER ENGINE MANUALS ARE AVAILABLE FROM YOUR LOCAL TEREX HANDLER DEALER.

ADJUST ENGINE VALVES

To Adjust: See engine manual for procedure.

CHECK FAN BELT TENSION

To Check: See engine manual for procedure.

CHECK FAN BELT CONDITION

To Check: See engine manual for procedure.

CHANGE TRANSMISSION OIL AND FILTER

To Change: Refer to procedure listed on page 5-13 of this manual.

CLICK HERE TO **DOWNLOAD** THE COMPLETE MANUAL

- Thank you very much for reading the preview of the manual.
- You can download the complete manual from: www.heydownloads.com by clicking the link below



- Please note: If there is no response to CLICKING the link, please download this PDF first and then click on it.

CLICK HERE TO **DOWNLOAD** THE COMPLETE MANUAL