

ORIGINAL INSTRUCTIONS - according to Directive 2006/42/EC, Annex I 1.7.4.1

# OPERATOR'S MANUAL

---

**FI06.7A**

**FI06.7**

**FI56.7A**

**FI56.7**

Motor Grader

**Part number 47421955**

1<sup>st</sup> edition English

May 2014



CLICK HERE TO **DOWNLOAD** THE COMPLETE MANUAL

- Thank you very much for reading the preview of the manual.
- You can download the complete manual from: [www.heydownloads.com](http://www.heydownloads.com) by clicking the link below



- Please note: If there is no response to CLICKING the link, please download this PDF first and then click on it.

CLICK HERE TO **DOWNLOAD** THE COMPLETE MANUAL

# 1 - GENERAL INFORMATION

## Note to the owner

These operating instructions are designed to familiarize the operator with the machine and its designated use.

The instruction manual contains important information about how to operate the machine safely, properly, and economically. Observing these instructions helps to prevent hazardous situations, to reduce repair costs and downtimes and to increase the reliability and service life of the machine.

The instruction manual must be supplemented by the respective national rules and regulations for accident prevention and environmental protection.

**NOTE:** *The operating instructions must always be available in the machine's driver's cab.*

The operating instructions must be read and used by any person in charge of carrying out work with or on the machine, such as:

- Operation, including setting-up, troubleshooting in the course of work, care, disposal of operation materials and consumables
- Maintenance (inspection, servicing, repair work) and/or
- Transport

In addition to the operating instructions and the mandatory rules and regulations for accident prevention and environmental protection in the user's country and at the place where the machine is to be used, the generally recognized technical rules for safe and proper work must be observed (Complies with the VDMA recommendation "Operating Instructions").

The operating instructions are intended for construction machine specialists. They cannot provide basic knowledge. This can be acquired, for example, in several days' instruction by one of our qualified mechanics or by attending one of our training courses for operators or maintenance personnel.

Your authorized dealer will be pleased to answer any questions you might have after reading the operating instructions.

All our operating manuals are issued in German and then translated. Even a good translation may give rise to questions which we will be pleased to answer.

The operating instructions are not work instructions for carrying out major repairs. Your authorized dealer will be glad to perform this work for you.

The documentation relating to the machine is listed by scope, quantity, and language in the shipping note of the machine or in the covering letter if supplied separately. The operating instructions and spare-parts list are marked with the machine's number.

Upon receipt of the consignment, please check that the documentation is complete and in the language you requested.

## Identification plates

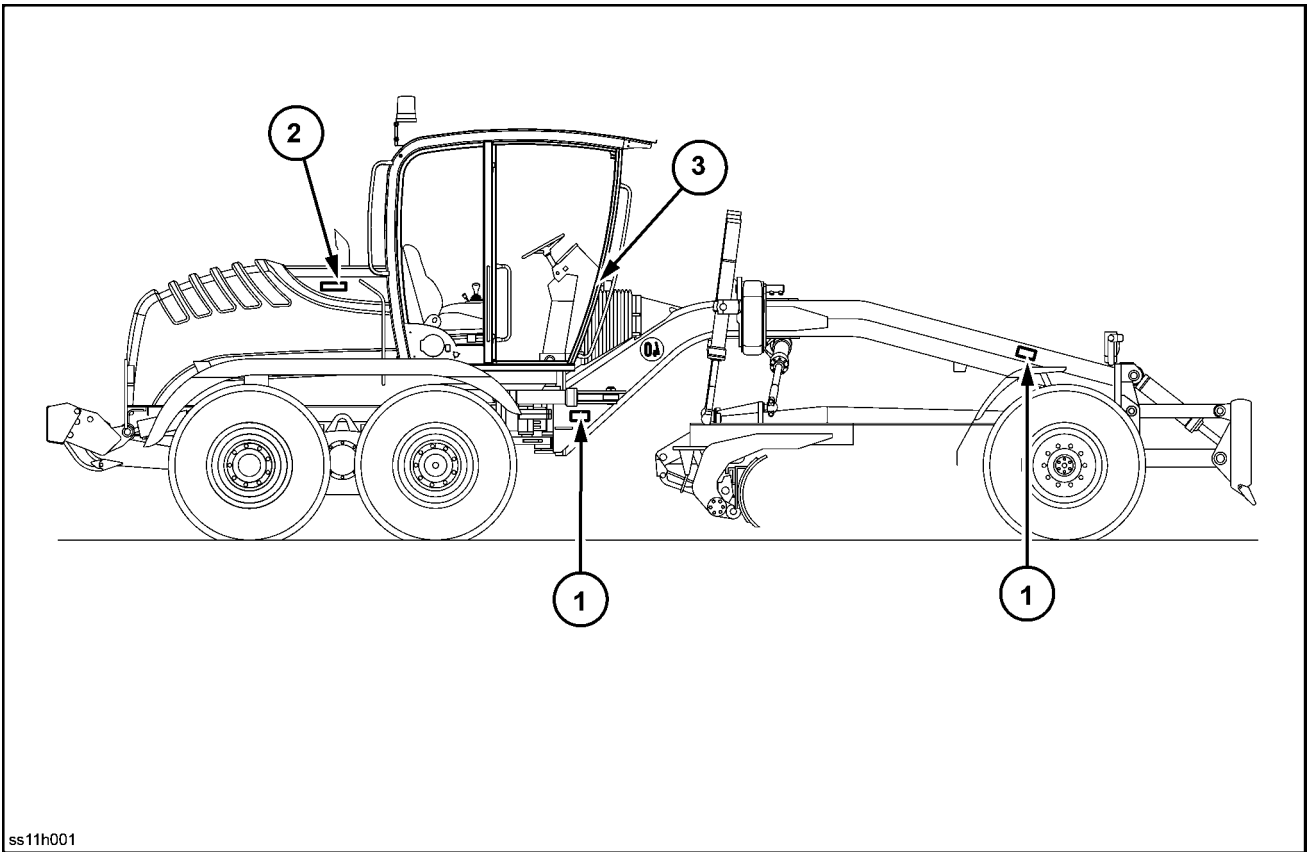

ss11h001

SS11H001 1

Pos.	Designation	Pos.	Designation
1	Model plate of the machine	3	Model plate of the cab
2	Model plate of the engine		

## CE declaration of conformity

On the following page you will find a copy of the "EC" Declaration of Conformity (EC DoC). The EC DoC is the manufacturer's declaration that the equipment is in compliance to relevant EU provisions. Please keep the original document in a safe place. Local authorities may require you to show this document in order to assure compliance of your equipment.

You can find the translation of this description in your country's language on the back of the original document. To better and more easily understand this document, you will find some explanatory notes below.

1. Those options or variants are listed at section 1.2 (see figure 1) which have safety related functions. Some of them are provided as standard, like FOPS or ROPS. See **1-17**.
2. All information which is required by EU Directive 2000/14/EC "Noise for Outdoor Equipment" is listed in section 2. Please refer your own original EC DoC for more specific equipment information. For more information about equipment guaranteed sound power level (LWA) see **2-29**. On the same page has specifications about station noise level (LpA) which are not dealt with in the above-mentioned EU Directive and therefore not indicated on it.
3. General serial number for this equipment type. The sequence of letters and numbers may vary depending on equipment configuration.
4. EC DoC serial number. Please make reference to this number when request information or support to New Holland about EC DoC.
5. Signature of a person authorized to sign the document on behalf of the company.

## Recovery and towing

The machine may only be towed, loaded, and transported in accordance with the operating instructions.

For towing of the machine, use only tow bars or towing ropes of adequate load-bearing capacity.

The tow bar or the towing rope must be free from damage. They must be designed in such a way that their calculated breaking load is equal to three times the tractive power of the towing vehicle.

The towing vehicle must have adequate tractive power. Drive slowly and carefully.

Nobody may be in the hazard zone of the tow bar or of the towing rope.

Tow the machine only if the brakes and the steering of the machine are fully operational and if the machine cannot be transported by any other means.

Non-operational machines may only be towed over such a distance as required for the recovery of the machine from the hazard zone.

After the recovery, the machine must be secured against inadvertent movements and unauthorized starting.

The towing speed must not exceed **8 km/h (5.0 mph)**.

When towing the machine, observe the prescribed transport position and itinerary.

The recommissioning procedure must be strictly in accordance with the instructions and precautions in the operator's manual.

Lift and handle all heavy components using lifting equipment with adequate capacity. Always support units or parts with suitable slings or hooks. Make sure that the work area is clear of all bystanders.

Shut off the engine before removing or installing the articulated joint lock.

Before starting the emergency lowering operation, make sure that no persons are present around the blade.

### **Mounting and dismounting**

Mount and dismount the machine only at designated locations that have handholds, steps, and/or ladders.

Do not jump off of the machine.

Make sure that steps, ladders, and platforms remain clean and clear of debris and foreign substances. Injury may result from slippery surfaces.

Face the machine when you mount and dismount the machine.

Maintain a three-point contact with steps, ladders, and handholds.

Never mount or dismount from a moving machine.

Do not use the steering wheel or other controls or accessories as handholds when you enter or exit the cab or operator's platform.

Remove oil, grease, soil, mud, snow, ice, and other material from the machine wheels as well as ramps and loading platforms on the transport vehicle.

### **Working at heights**

When the normal use and maintenance of the machine requires you to work at heights:

- Correctly use installed steps, ladders, and railings.
- Never use ladders, steps, or railings while the machine is moving.
- Do not stand on surfaces that are not designated as steps or platforms.

Do not use the machine as a lift, ladder, or platform for working at heights.

Always wear safety harnesses when working at greater heights. Wear an approved safety harness; it must be equipped with stabilizers and safety cables.

### **Tools and equipment**

Tools, lifting equipment, slings, chocks, and other equipment must be in safe operating and working condition.

Metal splinters can cause injury when accessory bolts are being driven in and out. Therefore, a brass or copper

mandrel should be used and protective goggles must be worn.

## Noise Emission

### Outside the machine

In operation the sound power level  $L_{WA}$  is:

Machine	dB (A)
F106.7/F106.7A	102
F156.7/F156.7A	101

Evaluated on identical machines in accordance with directive 2000/14/EC.

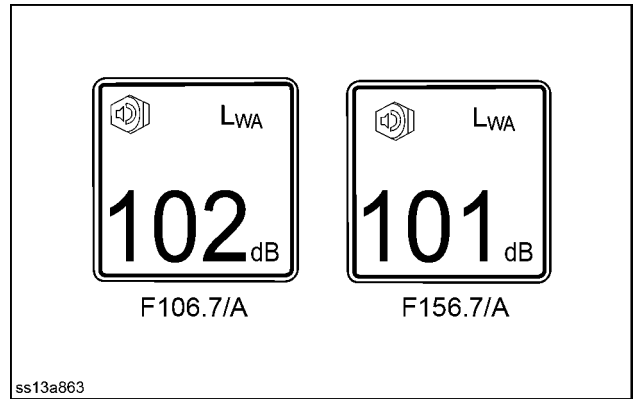

SS13A863 1

### Inside the cab

The emitted sound pressure level  $L_{pA}$  in the cab is:

Machine	dB (A)
F106.7/F106.7A	77
F156.7/F156.7A	78

The noise emissions listed apply to machines with standard settings.

For machines with e.g. increased cooling capacity, the sound pressure level and sound power level can be higher.

# 3 - CONTROLS AND INSTRUMENTS

## ACCESS TO OPERATOR'S PLATFORM

### Access doors

**⚠ WARNING**

**Fall hazard!**  
 Close the cab doors before driving on public roads.  
 Failure to comply could result in death or serious injury.

W1037A

### Opening the door

Unlock the door with the key (1).

Pull the door open with the handle (2) and swing it open into the stop position until the engagement hook (3) engages the bolts.

**NOTICE:** The cab door key is identical to the ignition key (1).

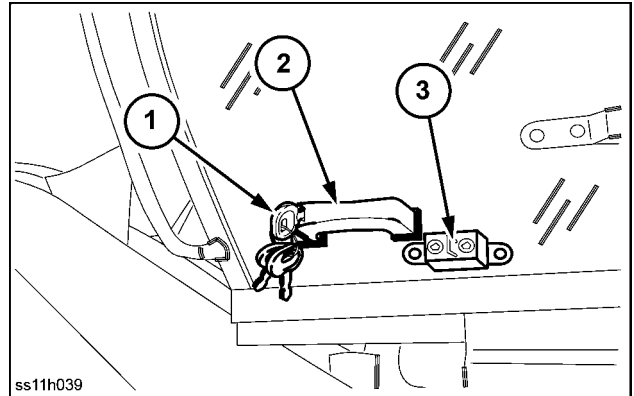

ss11h039

SS11H039 1

**⚠ WARNING**

**Fall hazard!**  
 The door must be completely open and latched in order to enter the cab or operate the machine with the door open. When the door is unlatched, it is free to move. Failure to comply could result in death or serious injury.

W1027A

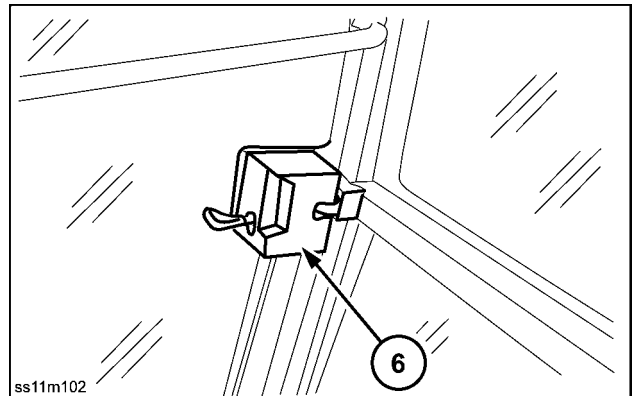

ss11m102

SS11M102 2

### Closing the door

Unlock the latched open door with the pulling handle (5) and swing it until it is closed and interlocked in the lock.

Lock the door the with key (1) (see figure 1).

After unlocking or locking the door latch (6) (see figure 2), each facing door can be opened or closed from inside even when the door is locked.

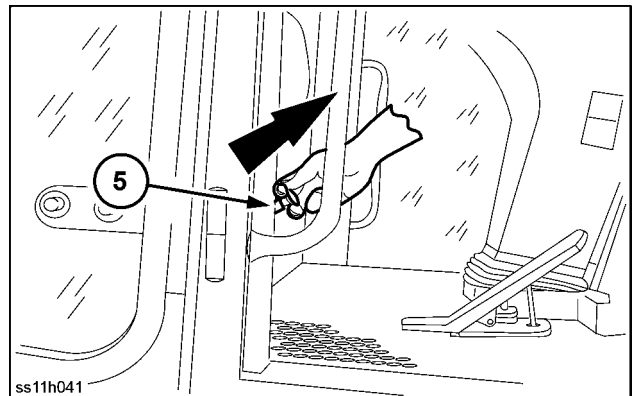

ss11h041

SS11H041 3

### Emergency exit

**NOTICE:** The right cab door is marked as Emergency exit. Before leaving the cab, the right side console is to be pushed to the rear.

## FORWARD CONTROLS

### Control elements/front

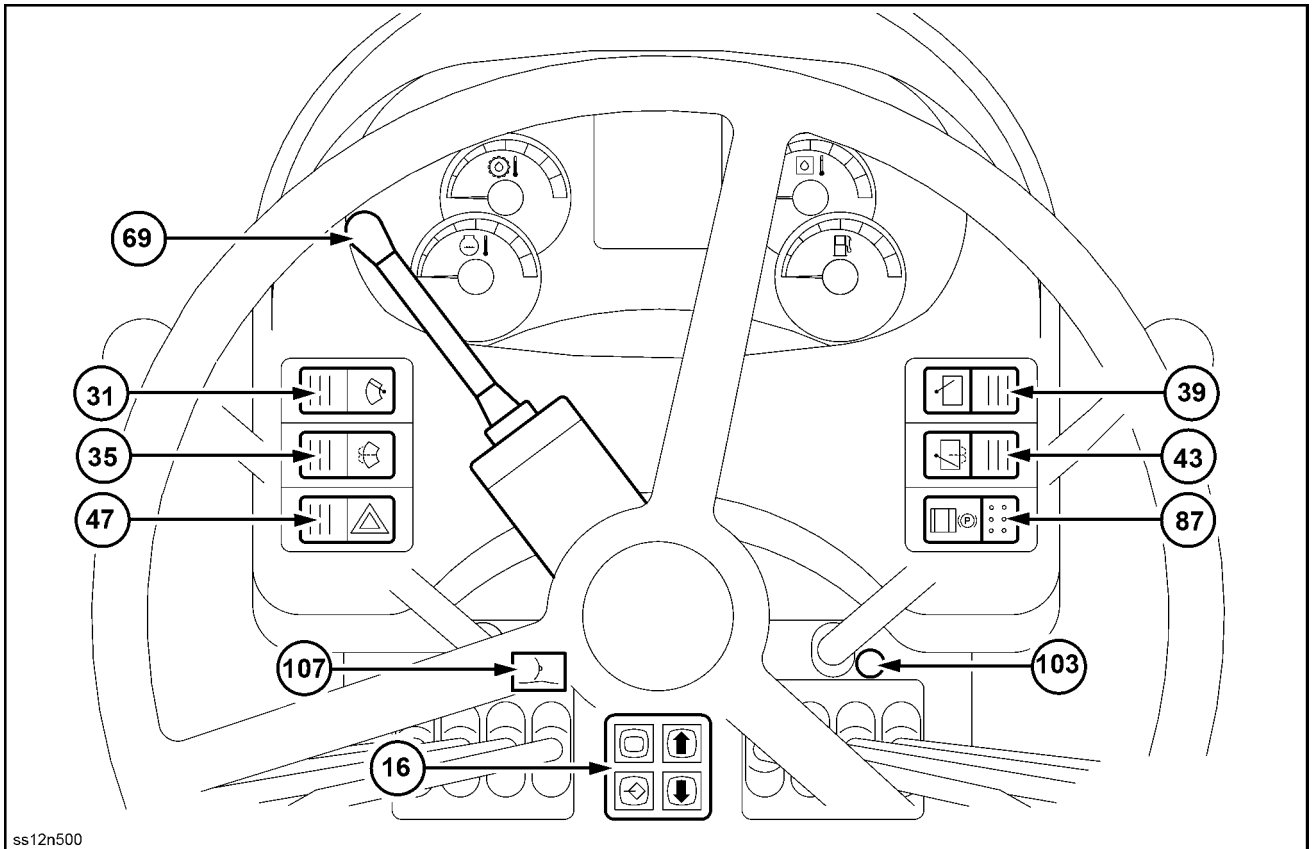

ss12n500

SS12N500 1

Pos.	Designation	Function	Symbol
16	Keypad	Navigation keys for multi-function display	
31	Switch	Windshield wiper, front window	
35	Pushbutton	Windshield washer, front window	
39	Switch	Windshield wiper, rear window	
43	Pushbutton	Windshield washer, rear window	
47	Switch	Hazard warning system	
69	Steering-column lever switch	Lighting	Turn signal, horn, headlamp flasher, high beam





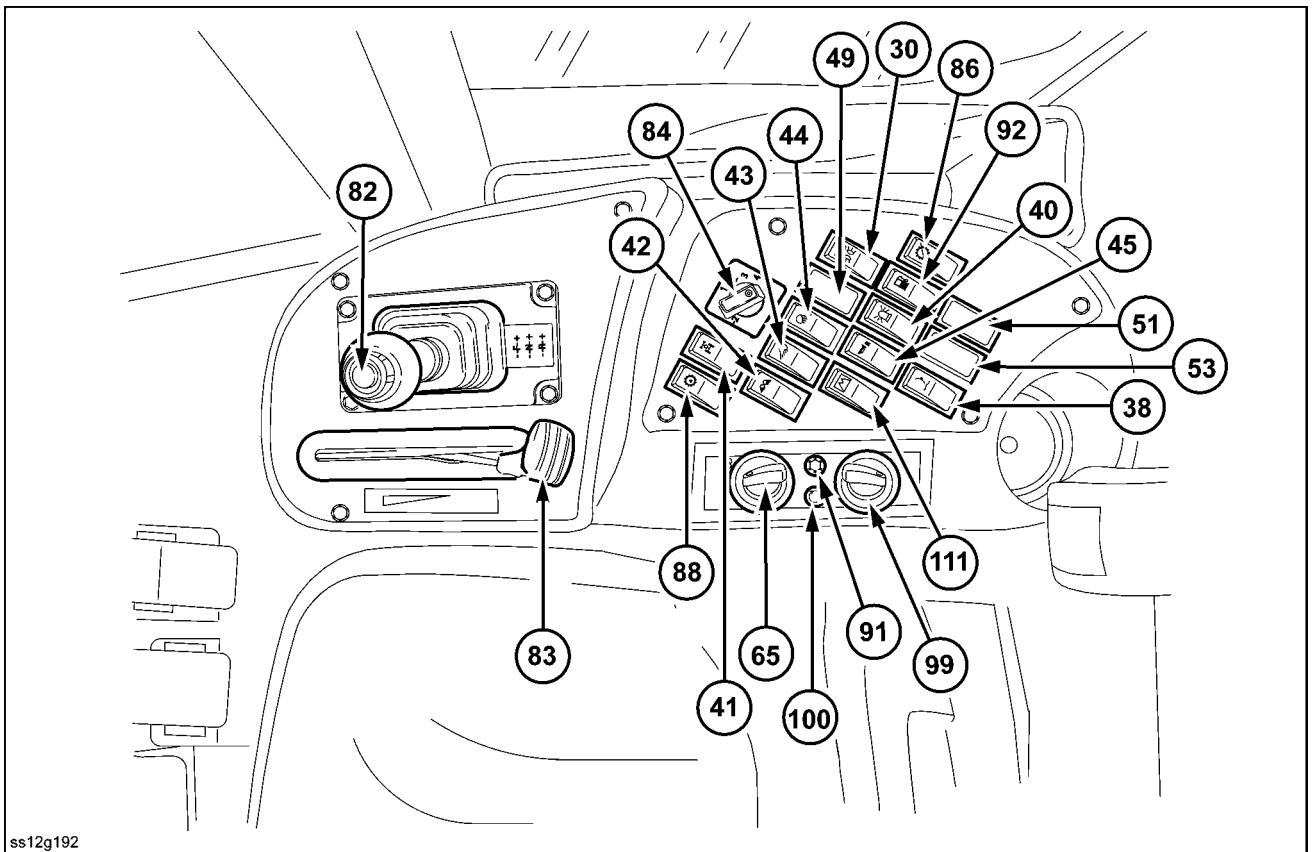

## RIGHT-HAND SIDE CONTROLS

### Right-hand side controls

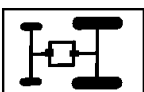

ss12g192

SS12G192 1

Pos.	Designation		Function	Symbol
30	Switch	Lighting	Side-marker lamps and low beam	
38	Switch	Floating position Option	Activate	
40	Switch	Rotary beacon Option		
41	Switch	Four-wheel drive Option		
42	Switch, 3-step	Floodlamps	Driver's cab, front/rear	
43	Switch	Floodlamps Option	Cab base, in front below	
44	Switch	Floodlamps Option	Rear	

## Gearshift lever - powershift transmission

### **⚠ WARNING**

**Driving hazard!**

**Never allow the machine to roll with the gearshift lever in neutral.**

**Failure to comply could result in death or serious injury.**

W1053A

Forward and reverse travel and the 6 forward and 3 reverse gears are selected with the gearshift lever (**82**).

All gears can be shifted under load.

The electronic transmission only shifts within the speed ranges of the individual gears.

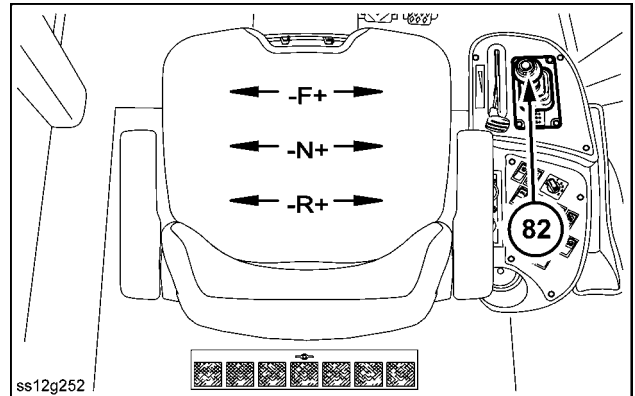

Scrolling further down displays travel information screen 1/TRIP 1.

Pos.	Designation	Dimension
1	Date of last reset	
2	Operating hours	h
3	Total fuel consumption	l
4	Fuel consumption per hour	l/h

Travel information screens 1 and 2 can be reset independently.

Pressing the UP key displays the previous screen again.

### Resetting the traveling data

Example: Travel information screen 2

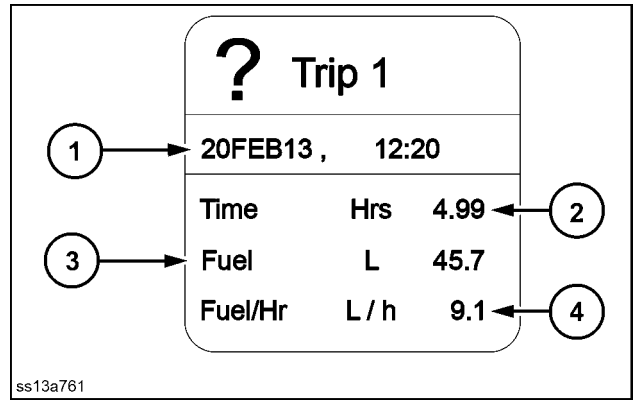

SS13A761 8

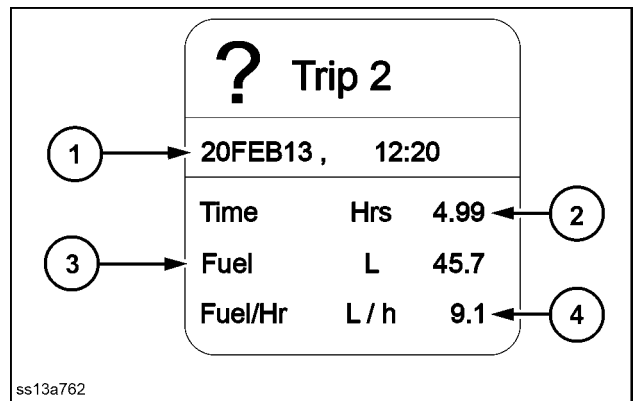

SS13A762 9

Call up the relevant travel information screen.

Press entry key/ENTER (B), the reset message is indicated on the travel information screen.

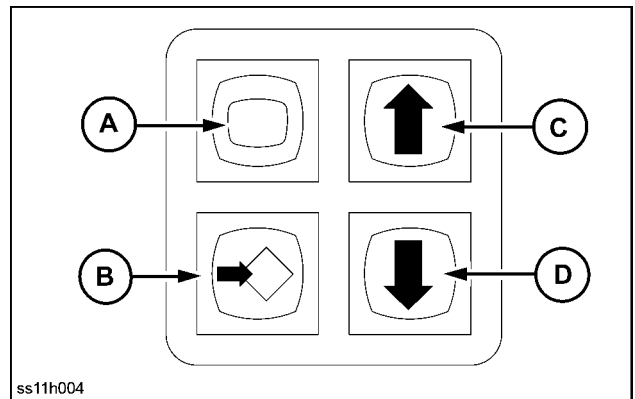

SS11H004 10

Pos.	Designation
1	Confirm

The travel information screen displays a reset message. Press the entry key/ENTER (B) (see figure 10) in this screen to delete the numbers and to reset the traveling data. The current date and time-of-day are displayed automatically. Operating hours, total fuel consumption, and average fuel consumption per hour are set back to zero.

Travel information screen 1 (see figure 8) can also be reset in the same way as travel information screen 2.

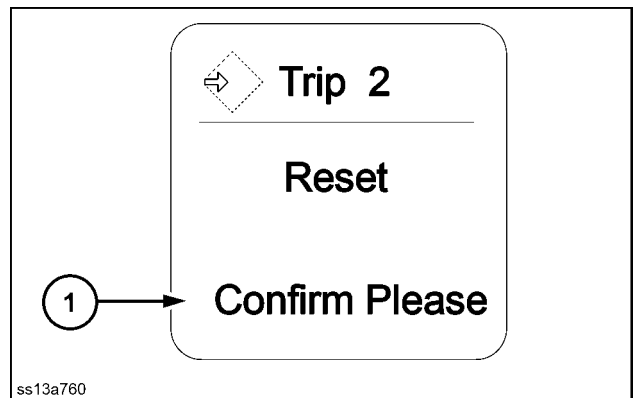

SS13A760 11

The respective model is selected with the arrow keys (C), (D) (see figure 1) and the selection confirmed with the ENTER key (B) (see figure 1). After selecting the model in screen (see figure 5) the Change Model mode screen is displayed.

Pos.	Designation
1	Change model OK
2	Restart (Model change/select screen)
3	Engine of the machine

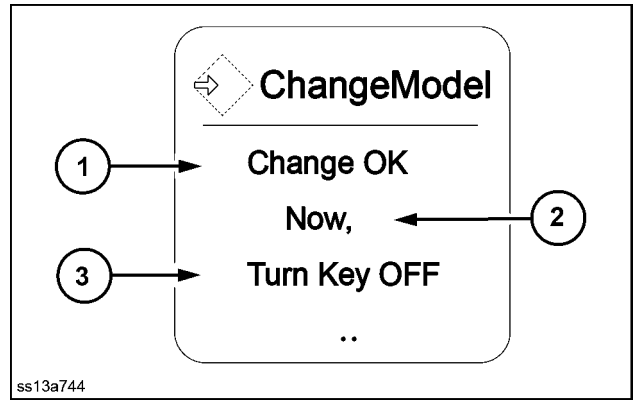

SS13A744 5

Turn ignition key to "0". After the "shutoff delay" has elapsed, turn the ignition switch back to "1".

The model change concerns only the display of the model name in the main screen. No model-specific parameters are loaded.

A press on the ESCAPE key (A) (see figure 1) displays the configuration screen again.

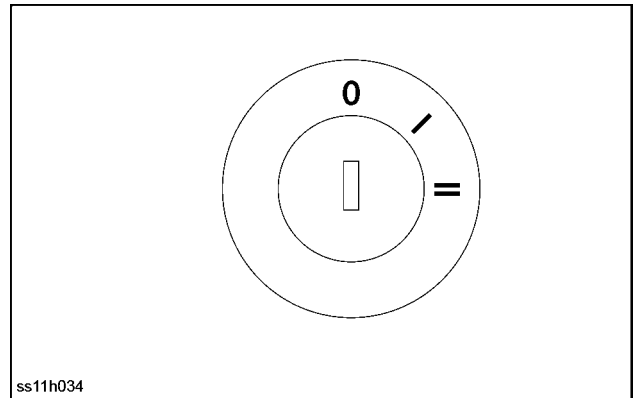

SS11H034 6

### Tires screen

The tires screen (2) (see figure 2) is selected with the arrow keys (C), (D) (see figure 1) and called up with the ENTER key (B) (see figure 1).

Pos.	Designation
1	Tire selection

A press on the ESCAPE key (A) (see figure 1) displays the configuration screen again.

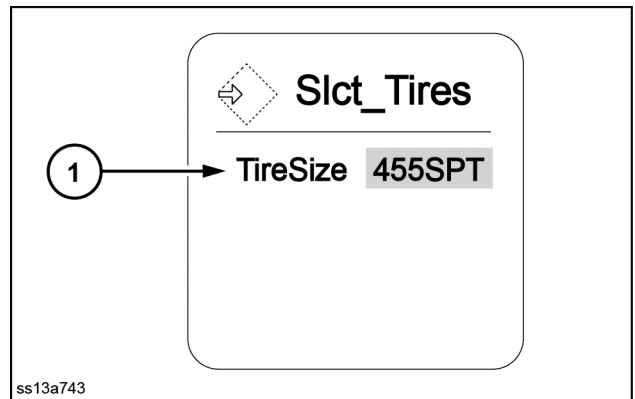

SS13A743 7

### Transmission calibration screen

The transmission calibration screen (3) (see figure 2) is selected and called up with the ENTER key (B) (see figure 1).

The menu on the configuration screen follows.

If the queried conditions do not apply, continue to follow the menu on the configuration screen.

If the queried conditions do apply, start the configuration.

After the end of the process, confirm OK with ENTER (B) (see figure 1).

If the process could not be successfully carried out, leave the menu with the ESCAPE key (A) (see figure 1).

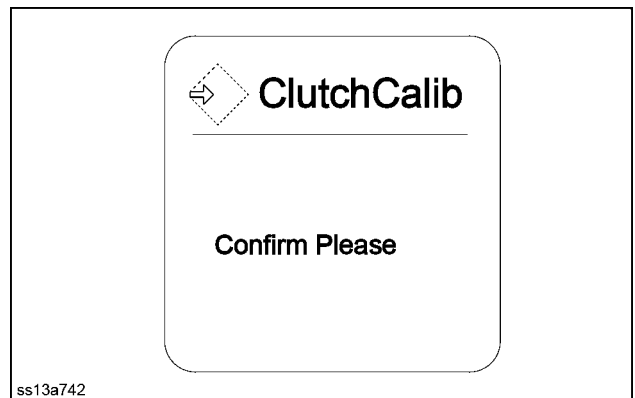

SS13A742 8

## Hydraulic fluid temperature

### Hydraulic fluid temperature display (7)

When the temperature is in the **(A)** range, move the hydraulic cylinders until the yellow main warning lamp goes off.

Under normal operating temperature conditions, the instrument needle is in range **(B)**. If the temperature continues to rise into range **(C)**, an oscillating tone is heard, the main warning lamp CAUTION lights up yellow, and a message is displayed on the screen (see table 1). If the temperature continues to rise further and if the needle of the instrument reaches range **(D)**, a continuous acoustic warning is sounded and the main warning lamp STOP lights up red.

**NOTICE:** Attention Instrument range **(A)**. See also 4-8.

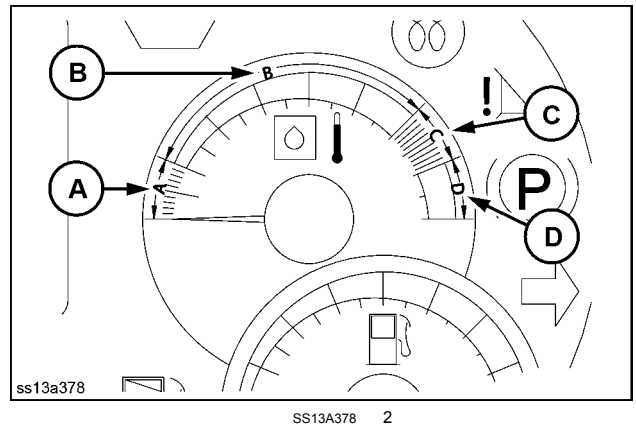
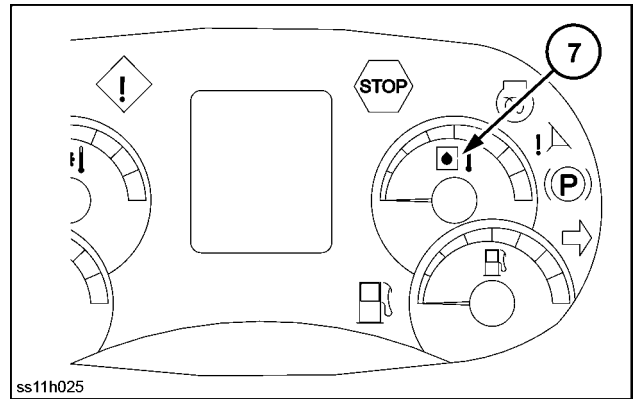

### Hydraulic fluid temperature indication

Table 1

Instrument display	Pos.	Condition	Main warning lamp	Display message
20 °C (68.0 °F) and below	A	Hydraulic fluid temperature too low	Caution (yellow)	Low Perf of GR Warming up Hyd Oil Temp
20 - 105 °C (68.0 - 221.0 °F)	B	Hydraulic fluid temperature normal		Full Perf of Grader allowed *
105 - 110 °C (221.0 - 230.0 °F)	C	Hydraulic fluid temperature is high	Caution (yellow)	Hyd Oil Temp Above Normal Press Return
110 °C (230.0 °F) and above	D	Hydraulic fluid temperature is very high	STOP (red)	Hyd Oil Temp Too High Press Return Limit usage (blinking)

\* The display message “Full Perf of Grader allowed” will only appear when the Hydraulic Oil Temperature and the Transmission Oil Temperature are in range.

**NOTICE:** Do not use the machine when the indicator lamp is lit up red and if the alarm sounds. Stop the machine and rectify the fault. Let the engine continue to idle.

- Turn the key in the key-switch (**73**) to position II. The engine starts.

**NOTICE:** Do not turn the key switch to position II while the engine is running, since this could damage the starter.

- Release the key. It returns to position I. Let the cold engine idle for **3 - 5 min** at about **1000 RPM** before using it under load.

**NOTICE:** If the main warning lamp (on the front console), see figure 2, blinks in operation and if the acoustic warning system sounds a continuous tone, stop the engine and shut it off to locate and rectify the cause of this problem.

**NOTICE:** If the warning lamps, see figure 2, do not go out when the engine is running, shut off the engine immediately. Locate and rectify the cause of the malfunction before restarting the engine.

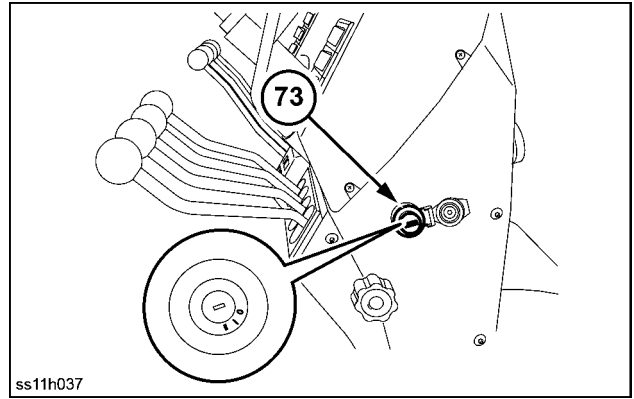

SS11H037 4

### Engine fails to start

If the engine fails to start, turn key-switch (**73**) to position 0 and repeat the starting procedure.

**NOTICE:** Never keep the starter switch in the starting position for more than **20 s** without interruption. Wait **2 min** between the attempts to start.

**NOTICE:** The engine cannot be started by towing the machine. Any attempt to start the engine by towing can cause transmission damage.

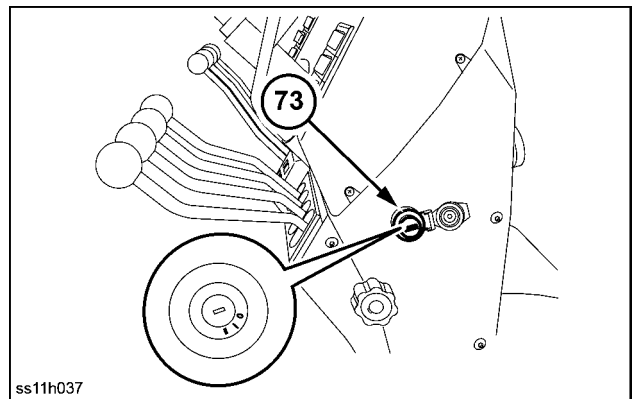

SS11H037 5

## 5 - TRANSPORT OPERATIONS

### PREPARING FOR ROAD TRANSPORT

#### Transporting the machine

#### ⚠ WARNING

##### Avoid injury!

Know all rules, regulations, laws, and required safety equipment for transporting or operating this machine on a road or highway. See your dealer to obtain a rotating beacon, backup alarm, and other safety equipment.

Failure to comply could result in death or serious injury.

W1063A

#### ⚠ WARNING

##### Avoid injury!

Remove oil, grease, soil, mud, snow, ice, and other materials from the machine wheels as well as ramps and loading platforms on the transport vehicle.

Failure to comply could result in death or serious injury.

W1055A

**NOTICE:** The responsibility for securing the load in commercial goods transport lies with the:

1. Forwarder
2. Owner of the vehicle
3. Driver
4. Sender

Familiarize yourself with all applicable laws and regulations of the country concerned. Make sure the tractor vehicle, the low-bed trailer, and the machine itself are equipped with the prescribed safety devices.

1. Place chocks in front of and behind the wheels of the low-bed trailer.
2. Lock the articulated joint.
3. Drive the machine slowly and carefully onto the low-bed trailer.
4. Lower the working equipment to the low-bed trailer platform.
5. Apply the parking brake.
6. Shut off the engine.
7. Withdraw the ignition key.
8. Close the stopcock (if the ripper is installed).
9. Set the gearshift lever (**82**) to position N.
10. Fasten the machine on the low-bed trailer with appropriate lashing materials at the tie-down points (see figures 3, 4, and 5) provided for this purpose.
11. Measure the height of the machine between the highest machine part and the ground. The low-bed trailer must be set for "road transport".

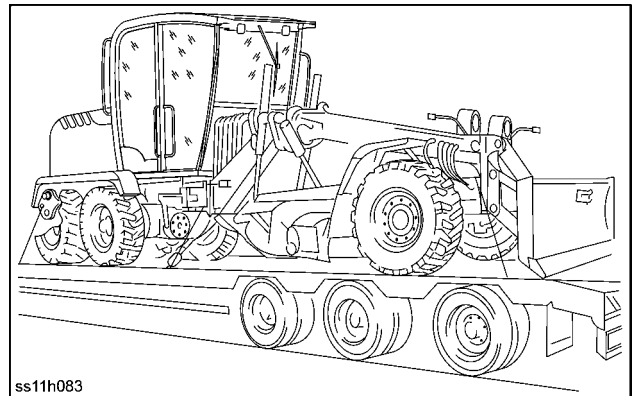

SS11H083 1

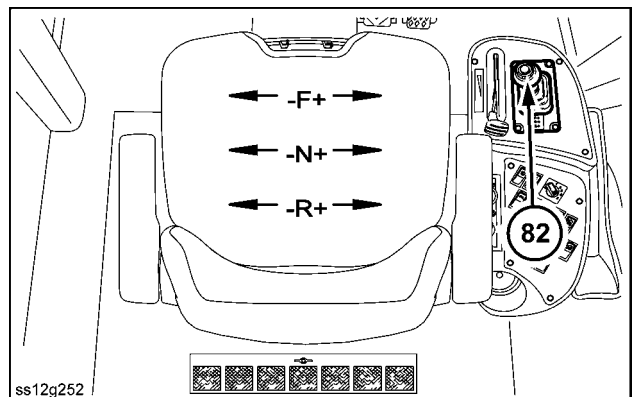

SS12G252 2

**NOTICE:** Unlock the articulated-joint lock before unloading the machine.

**Re-adjusting the swivel arm to the left**

1. Completely extract the blade swivel cylinder with the control lever **(74)**. Then set the blade with the control levers **(75)** and **(76)** on the ground to relieve the hydraulic system.

Disengaging the swivel arm lock:

2. Depress button **(104)** (see figure 2) and hold. The locking pin disengages from the swivel arm.
3. Put the swivel arm into position **(5)** using the control levers **(74)**, **(75)**, and **(76)**.
4. Release button **(104)** (see figure 2) shortly before reaching position **(5)**. The locking pin engages by spring force.

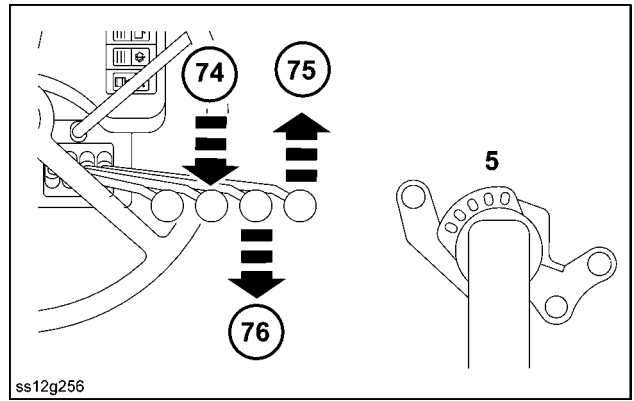

## 7 - MAINTENANCE

### GENERAL INFORMATION

#### Instructions

This section gives full details of the service procedures necessary to maintain your machine at peak efficiency.

#### Safety precautions

**NOTE:** – Read and observe **2-2** and following.  
– Secure the machine as described under **7-5**.

**NOTE:** Dispose of used filters and fluids properly.

#### Disassembly, decommissioning, or scrapping the machine

When the machine is taken out of service because it is damaged beyond repair or has reached the end of its useful life, disassembly, scrapping and/or recycling of components, fluids, etc. must be performed only by a qualified technician using service instructions and in compliance with local laws and regulations.

#### Preventing system contamination

To prevent contamination when changing oils, filters, etc., always clean the area around filler caps, level and drain plugs, dipsticks, and filters prior to removal. Before connecting remote cylinders, ensure that oil contained within them is clean, has not degenerated due to long storage, and is of the correct grade.

To prevent dirt entry during greasing, wipe dirt from the grease fittings before greasing. Wipe excess grease from the fitting after greasing.

#### Flexibility of maintenance intervals

The intervals listed in the lubrication and maintenance chart are guidelines to be used when operating in normal working conditions.

Adjust the intervals for environmental and working conditions. Intervals should be shortened under adverse (wet, muddy, sandy, extremely dusty) working conditions.

#### Lubrication and maintenance chart

On page **7-25** and following you can find a list with the intervals when routine checks, lubrication, service, and/or adjustments should be performed. Use the chart as a quick-reference guide when servicing the machine. The operations follow the chart.

#### Warranty

One of the preconditions for warranty is that the following compulsory servicing work has been performed by your authorized dealer or authorized workshop:

1. Compulsory servicing at 250 operating hours after commissioning.
2. Compulsory servicing at 500 operating hours after commissioning.

The proper execution of the compulsory servicing works must be documented on the service checklists.

CLICK HERE TO **DOWNLOAD** THE COMPLETE MANUAL

- Thank you very much for reading the preview of the manual.
- You can download the complete manual from: [www.heydownloads.com](http://www.heydownloads.com) by clicking the link below



- Please note: If there is no response to CLICKING the link, please download this PDF first and then click on it.

CLICK HERE TO **DOWNLOAD** THE COMPLETE MANUAL

**NOTE:** – Read and observe 2-2 and following.  
– Secure the machine as described under 7-5.

**NOTE:** If the machine is equipped with a lubrication system (option), then all lubricating nipples are connected by lubrication lines to the lubrication system. The illustration and the table only provide an overview about which bearing points are lubricated.

Pos.	Lubricating points	Quantity
8	Articulated frame steering cylinders	2x2
9	Swivel arm arrestor bolts	1
10	Blade swivel arm bearing	2
11	Blade swivel cylinder bearing	4
12	Blade slewing bolt	1
13	Blade-lifting cylinder bearing	2 x 3
14	Blade-lifting cylinder mount	2 x 1
15	Pitch adjustment cylinder bearing	2
16	Blade-slewing ring	3
17	Pitch adjuster bearing	2 x 1
18	Rotary oil feed rotor	1

For correct oils see also 7-14.

**V. Greases for bearing points and slewing rings**

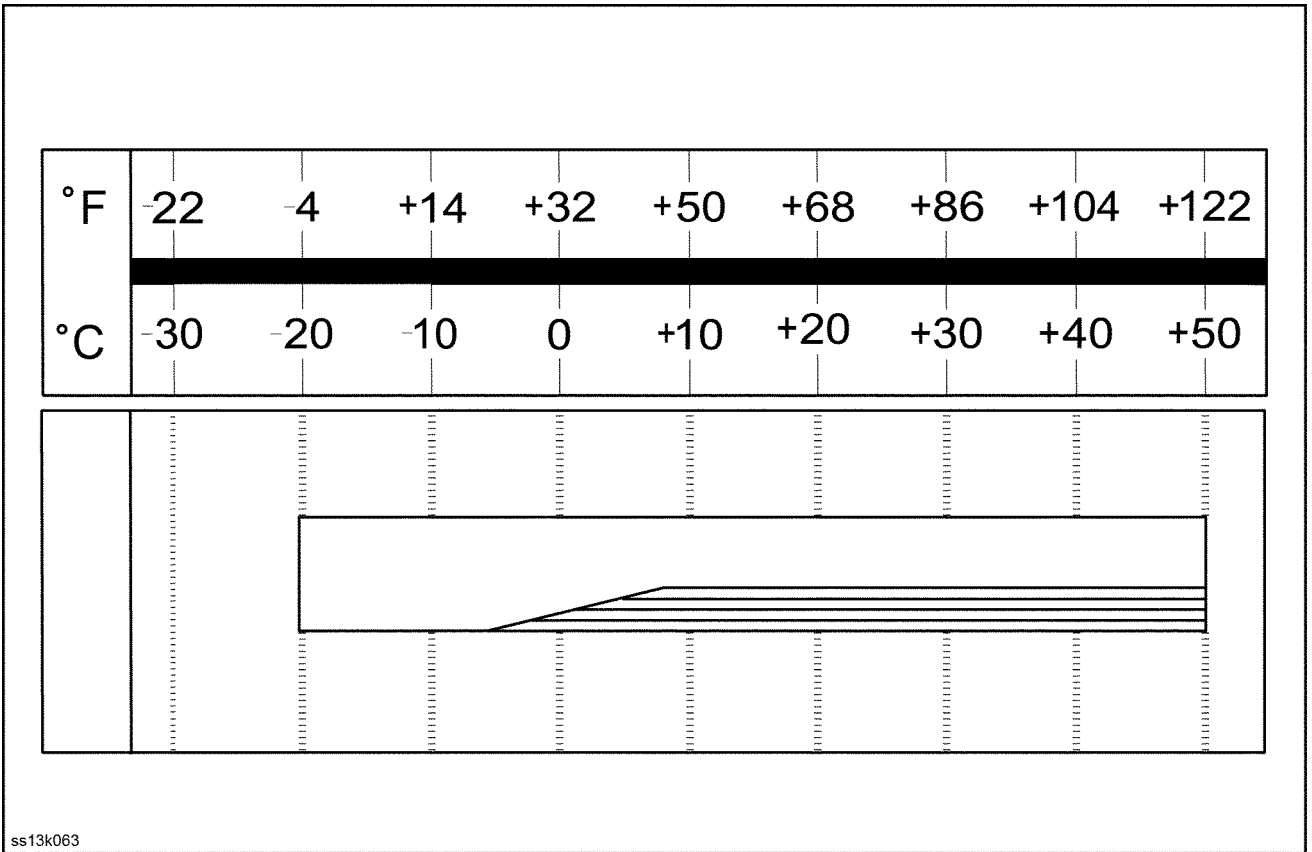

SS13K063 8

Specification:

- NLGI 2

**Oils**

Multipurpose Grease (NH 710 A)  
e.g.: AMBRA GR9

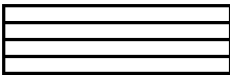

For central lubricating systems and tensioning systems.

4. Check the oil level, then top up through the filler opening as far as the "max" mark (see figure 3). (For oil quality see 7-14 and for oil quantity see 7-23).

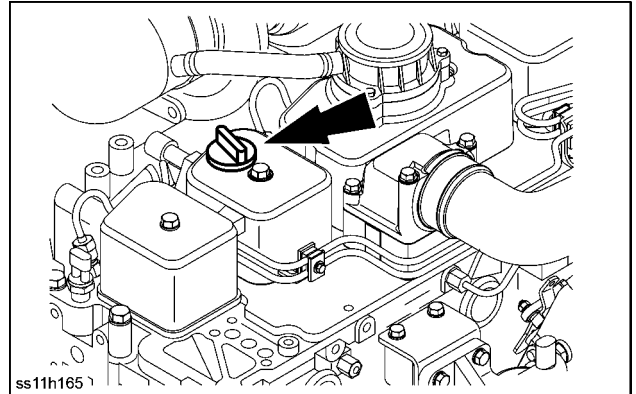

SS11H165 2

5. If the oil level is only just above the "min" mark, it must be topped up.  
**3 l (0.8 US gal)** can be filled in between the "min" and "max" marks.

**NOTICE:** The oil level must not be allowed to fall below the "min" mark or rise above the "max" mark.

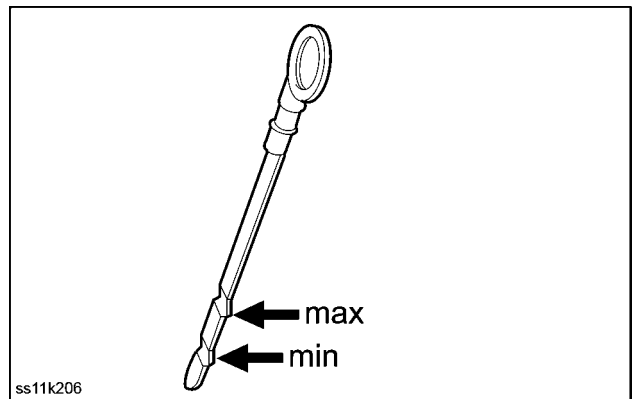

SS11K206 3

## Emergency release of the parking brake

### ⚠ WARNING

**Unexpected machine movement!**

**Make sure that you secure the machine with wheel chocks before you perform this procedure.  
Failure to comply could result in death or serious injury.**

W1221A

**NOTE:** If the pressure supply fails, the parking brake can be released mechanically.

1. Secure the machine against inadvertent movement.
2. Loosen the screw cap by turning anti-clockwise, and remove it.
3. Loosen the locknut (1) and unscrew it till it reaches the end of the adjusting screw (2).
4. Turn the adjusting screw (2) anti-clockwise until the brake disk is completely free.

**NOTE:** For emergency release, a minimum torque of **70.0 N·m (51.6 lb ft)** must be applied to the adjusting screw (2).

5. Screw in the locknut (1) up to the piston position and slightly tighten with the adjusting screw (2).
6. Turn the screw cap clockwise by several thread turns (to protect from dirt).

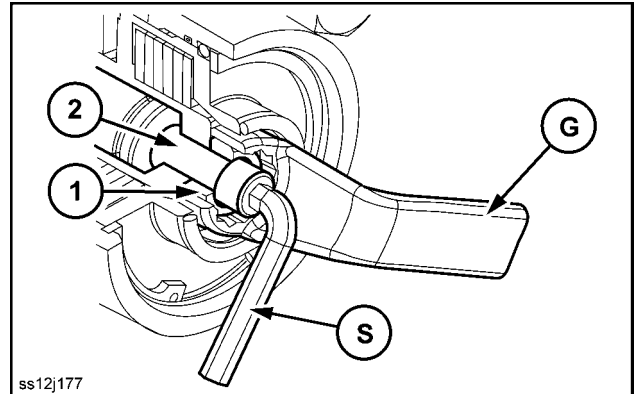

SS12J177 5

## ONCE AFTER 250 HOURS

### Maintenance - Check

1. Functionality and integrity
  - Hydraulic system
  - All lines, fittings, and connections for leaks
  - Steering
2. Pressure
  - Hydraulic system operating pressure
3. Tension
  - Chain
4. Tightness
  - All screws

### Maintenance - Replace

1. Replace
  - Fuel filter
  - Hydraulic return flow filter
  - Front-wheel drive oil filter (Only all-wheel version)
  - Powershift transmission oil filter

### Maintenance - Change fluid

1. Change
  - Rear axle oil
  - Blade slewing gear oil
  - Powershift transmission oil

### Maintenance - Grease

1. Grease
  - Front/tandem axle
  - Blade
  - Frame
  - Steering cylinder bearing

5. Carefully insert the new filter cartridge **(4)** into the hydraulic reservoir.
6. Check the gasket **(6)** and the spring **(5)** of the cap **(3)** for damage and replace it if necessary (see figure 2).
7. Put the cap **(3)** (see figure 1) back in place and tighten it.

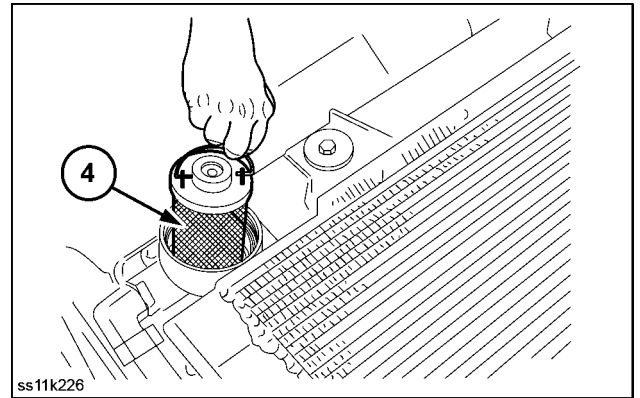

SS11K226 3

## 7 - MAINTENANCE

6. Fill engine oil in through the filler opening until the oil level reaches the “max” mark on the dipstick.
7. Start up the engine and check that the cartridge/engine connection is oil-tight.
8. Check the oil level (see also **7-30**).

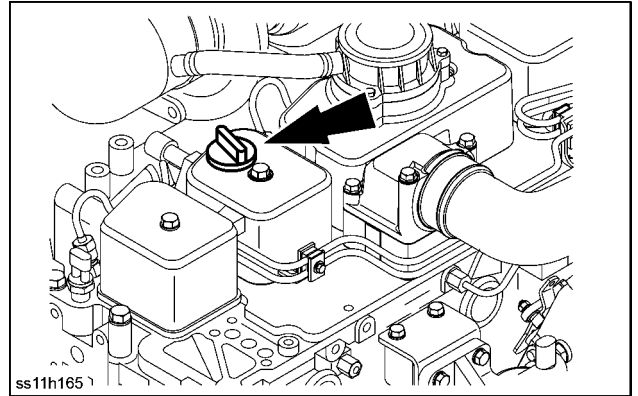

SS11H165 2

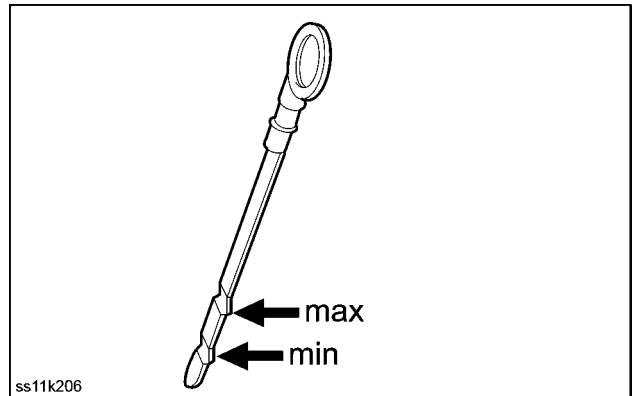

SS11K206 3

## Change the differential gear on rear axle oil

### **⚠ WARNING**

#### **Chemical hazard!**

**When handling fuel, lubricants, and other service chemicals, follow the manufacturer's instructions. Wear Personal Protective Equipment (PPE) as instructed. Do not smoke or use open flame. Collect fluids in proper containers. Obey all local and environmental regulations when disposing of chemicals.**

**Failure to comply could result in death or serious injury.**

W0371A

**NOTE:** – Read and observe 2-2 and following.

– Secure the machine as described under 7-5.

1. Change the differential gear side reducer gear oil.

## Change the tandem box on rear axle oil

### **⚠ WARNING**

#### **Chemical hazard!**

**When handling fuel, lubricants, and other service chemicals, follow the manufacturer's instructions. Wear Personal Protective Equipment (PPE) as instructed. Do not smoke or use open flame. Collect fluids in proper containers. Obey all local and environmental regulations when disposing of chemicals.**

**Failure to comply could result in death or serious injury.**

W0371A

**NOTE:** – Read and observe 2-2 and following.

– Secure the machine as described under 7-5.

1. Change the tandem (chain case) swing unit oil.

## Grease the front wheel bearing (Only all-wheel version)

**NOTE:** – Read and observe 2-2 and following.

– Secure the machine as described under 7-5.

1. Grease the front wheel bearing.

## Check and adjust the hydraulic pressure

- All pressure relief valves in the hydraulic system have been set at the factory to the prescribed operating pressure and are protected by seals.
- Have the operating pressures checked and readjusted by your authorized dealer.

## STORAGE

### Decommissioning procedure

If the machine is to be decommissioned for longer than 1 month, the following activities are to be carried out:

1. Place the machine on an even surface in a building or, if this is not possible, in the open under a tarpaulin.
2. The machine should be jacked up to protect the tires. Once the machine has been jacked up, then the tire pressure should be reduced to **0.7 bar (10.2 psi)** or less.
3. If the machine is stored outside, then it must be completely covered with a tarpaulin that also covers the tires to protect the machine from the effects of weather, sunshine, and rain.

Prior to decommissioning, the following activities are to be carried out:

1. Clean the machine.
2. Check the machine for damage and missing parts. Replace parts if necessary.
3. Block the articulated joint.
4. Lower work implements to the ground.
5. Grease the machine thoroughly. Grease the exposed piston rods or brush them with a preserving agent. Contact your authorized dealer.

**NOTICE:** *When the machine is recommissioned, the protective film will automatically disappear but grease must be removed.*

6. Check the oil level and top up as necessary.
7. Clean or replace the air filter element.
8. Check the coolant level. If you had planned to change the coolant in the next 100 operating hours, change the coolant now.
9. Remove the key. Remove the batteries and clean the battery compartment. Ensure that no traces of acid remain. Store the batteries in a cool and dry room where the temperature is above **0 °C (32.0 °F)** or remove the battery cable from the minus pole.
10. Touch up paint work where necessary.
11. Close off the air filter inlet and the exhaust pipe.
12. Remove the key and hang a sign saying "Do not operate" on it.
13. Close the engine hood and cab doors.

## Fuse/relay box 1F/1K

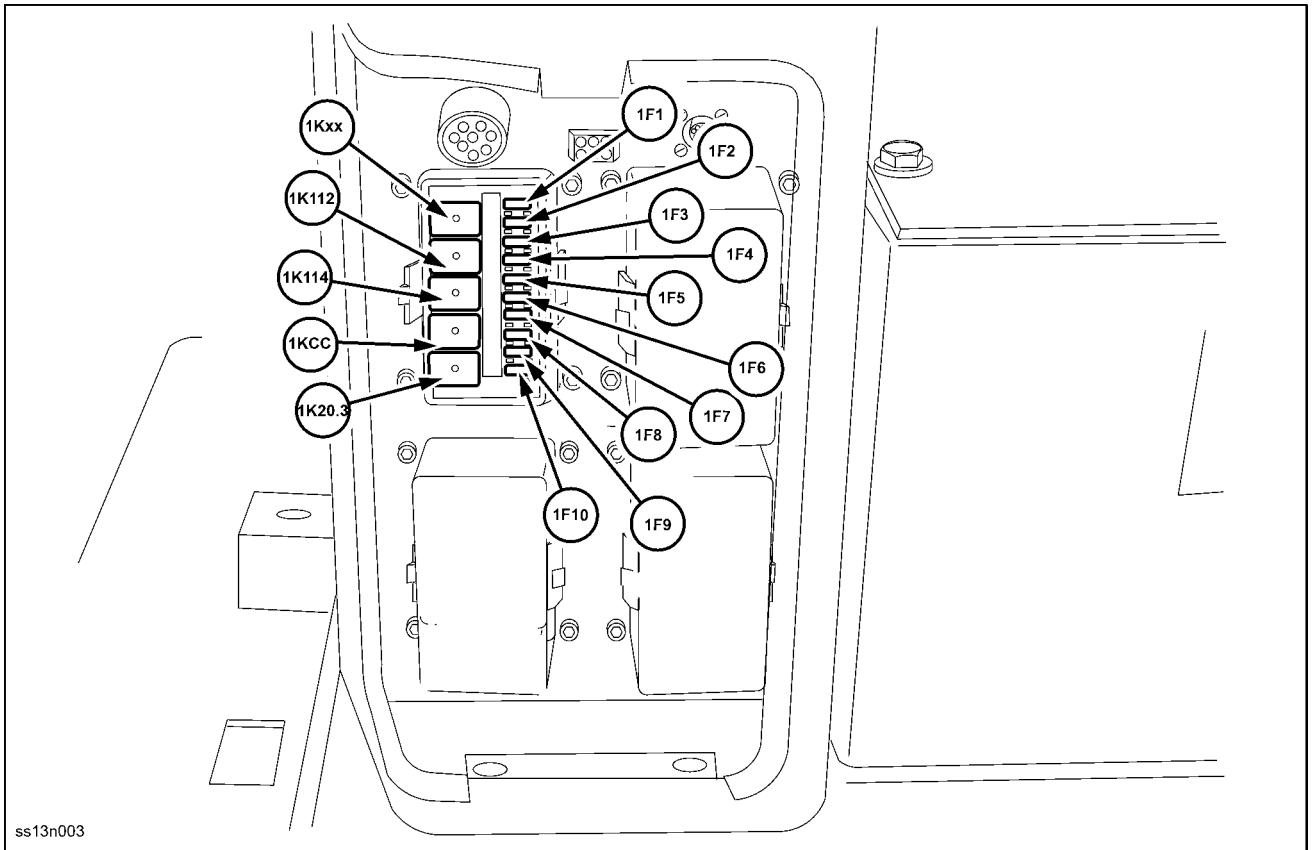

ss13n003

SS13N003 4

Fuse/relay designation	Amperes	Color code	Consumer
1F1	10 A	Red	AIC power supply
1F2	30 A	Green	EDC power supply
1F3	10 A	Red	Starter switch S1 to EDC
1F4	5 A	Beige	Voltmeter input (AIC)
1F5	20 A	Yellow	Filter heater
1F6	10 A	Red	Voltage transformer, radio gateway, power outlet
1F7	5 A	Beige	Interior cab light
1F8	7.5 A	Brown	Starter switch S1, starter relay K1.5
1F9	5 A	Beige	Relay voltmeter 1K112, alternator, refueling system, filling level sensor
1F10	5 A	Beige	Diagnosis socket X123
1Kxx			Reserve
1K112			Relay voltmeter
1K114			Relay start request
1KCC			Relay start control
1K20.3			Relay filter heater

### Rear light/Reversing light

1. Loosen the screws (5) and remove the glass (6) carefully from the housing.

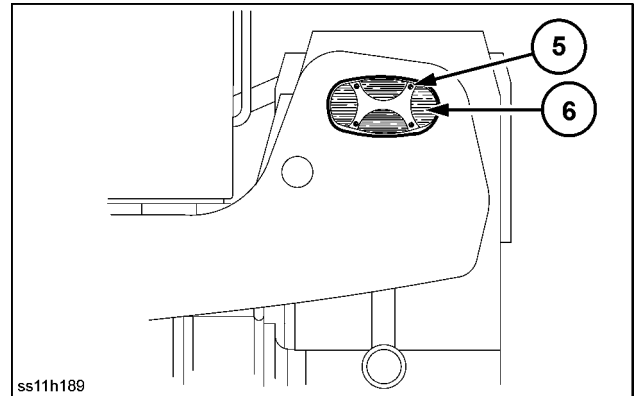

SS11H189 8

2. Replace defective bulbs.
  - (1) – Bulb for reversing light
  - (2) – Bulb for brake light
  - (3) – Bulb for turn signal light
  - (4) – Bulb for tail light
3. Reassemble in reverse order.

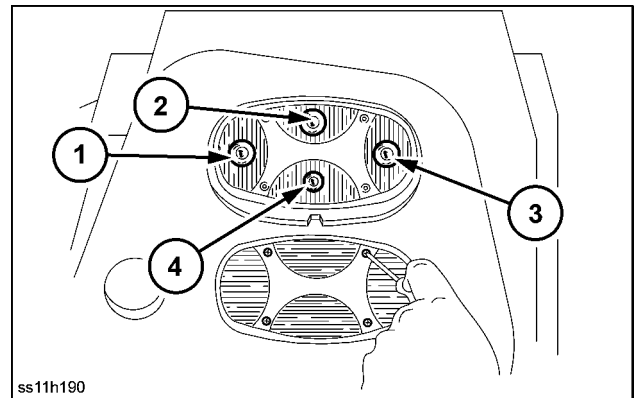

SS11H190 9

### Number plate light

1. Loosen the screw (32) and withdraw the light housings (33).
2. Replace the defective bulb (34).
3. Reassemble in reverse order.

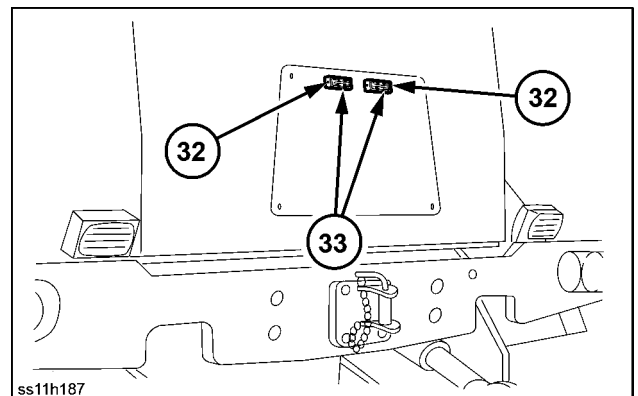

SS11H187 10

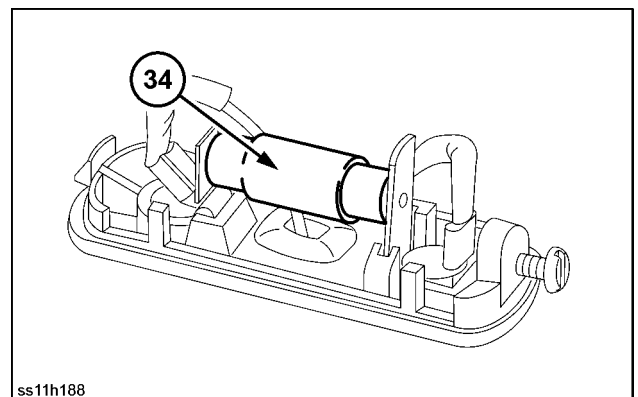

SS11H188 11

# 8 - TROUBLESHOOTING

## FAULT CODE RESOLUTION

### Clear fault memory

Main screen:

These settings can also be changed by the driver.

Sector	Designation
1	The number of operating hours is displayed briefly after the ignition is turned on; after the engine is started, the engine speed is displayed; after setting off, the traveling speed is displayed.
2	Travel direction display Forwards (↑), Reverse (↓), Idling (N) plus the maximum permitted gear for automatic operation. Indicates the transmission operating mode. A = Automatic mode M = Manual mode
3	This sector is subdivided into 2 boxes. A: For the four-wheel drive model the FWD symbol. B: Time-of-day display format ( 12 h or 24 h).

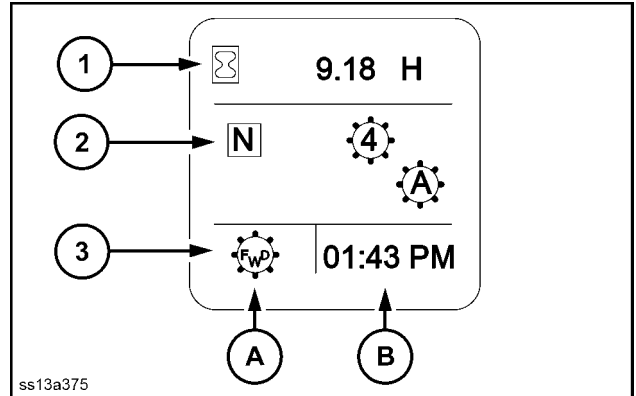

ss13a375

SS13A375 1

2. Press and hold the ENTER key (B) for about 2 s until the "Select" menu (see figure 3) appears.

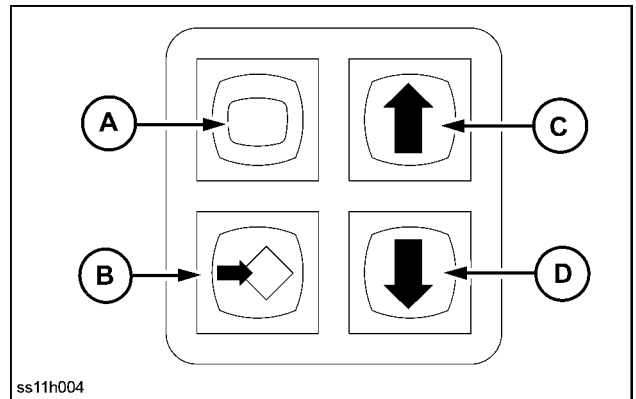

ss11h004

SS11H004 2

3. Press the DOWN key (D) (see figure 2) six times to go to the "Config" (7) menu option.
4. Select "Config" (option label is highlighted).
5. Press ENTER.

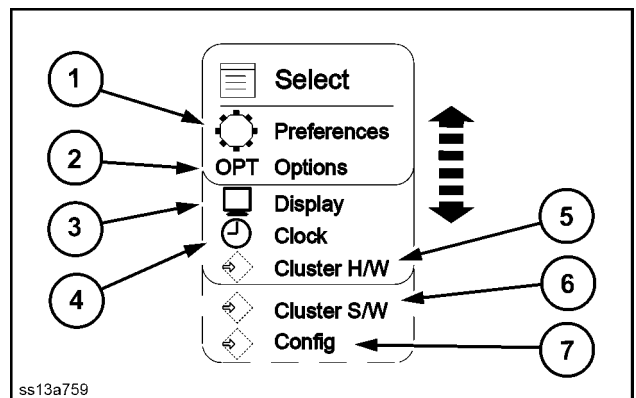

ss13a759

SS13A759 3

<b>Problem</b>	<b>Possible Cause</b>	<b>Correction</b>
<b>3179</b> (yellow indicator lamp)	CAN message BC2EDC2: time-out	CAN controller of vehicle computer faulty, vehicle computer power supply too low, vehicle computer not installed, CAN connecting cable of vehicle computer disconnected or broken. Short circuit in wiring. Check whether the vehicle computer is installed and correctly connected to the on-board network. Check that the CAN controller and its power supply are functioning correctly. Check the wiring.
<b>3180</b> (yellow indicator lamp)	CAN message VCM2EDC1: time-out	CAN controller of vehicle control unit (VOM) faulty, vehicle control unit power supply too low, vehicle control unit not installed, CAN connecting cable of vehicle control unit disconnected or broken. Short circuit in wiring. Check whether the vehicle control unit is installed and correctly connected to the network. Check that the CAN controller and its power supply are functioning correctly. Check the wiring.
<b>3188</b> (yellow indicator lamp)	Cylinder 1: load interruption	Cable broken or wiring disconnected or injector faulty. Check wiring or replace injector.
<b>3192</b> (yellow indicator lamp)	Cylinder 2: load interruption	Cable broken or wiring disconnected or injector faulty. Check wiring or replace injector.
<b>3196</b> (yellow indicator lamp)	Cylinder 3: load interruption	Cable broken or wiring disconnected or injector faulty. Check wiring or replace injector.
<b>3200</b> (yellow indicator lamp)	Cylinder 4: load interruption	Cable broken or wiring disconnected or injector faulty. Check wiring or replace injector.
<b>3204</b> (yellow indicator lamp)	Cylinder 5: load interruption	Cable broken or wiring disconnected or injector faulty. Check wiring or replace injector.
<b>3208</b> (yellow indicator lamp)	Cylinder 6: load interruption	Cable broken or wiring disconnected or injector faulty. Check wiring or replace injector.
<b>3210</b> (yellow indicator lamp)	Bank 1: general short circuit at injection cable	Short circuit between high-pressure side and battery or ground. Check wiring or replace injector.
<b>3211</b> (yellow indicator lamp)	Bank 1: short circuit in low-pressure side of the injector cable to ground	Short circuit to ground in the low-pressure side of the injector cable. Check wiring or replace injector.
<b>3212</b> (yellow indicator lamp)	Bank 1: no signal	Check the wiring.
<b>3213</b> (yellow indicator lamp)	Bank 1: unclassified fault	Depending on the pattern, there may be different causes for the fault, even an internal ECU fault. Check wiring and injection signals; replace ECU.
<b>3218</b> (yellow indicator lamp)	Bank 2: general short circuit at injection cable	Short circuit between high-pressure side and battery or ground. Check wiring or replace injector.
<b>3219</b> (yellow indicator lamp)	Bank 2: short circuit in low-pressure side of the injector cable to ground	Short circuit to ground in the low-pressure side of the injector cable. Check wiring or replace injector.
<b>3220</b> (yellow indicator lamp)	Bank 2: no signal	Check the wiring.

## 8 - TROUBLESHOOTING

<b>Problem</b>	<b>Possible Cause</b>	<b>Correction</b>
<b>4308</b> <b>(white indicator lamp)</b>	Battery voltage too high	Check batteries. Check (+) cable between batteries and TCU. Measure voltage at contact 35 in TCU connector.
<b>4309</b> <b>(red indicator lamp)</b>	Fault in VPS1 power supply to solenoid switch	Check fuse A2. Check cable between control valve and TCU. Check connector between control valve and TCU. Replace TCU.
<b>4310</b> <b>(red indicator lamp)</b>	Fault in VPS2 power supply to solenoid switch	Check fuse A2. Check cable between control valve and TCU. Check connector between control valve and TCU. Replace TCU.
<b>4325</b> <b>(yellow indicator lamp)</b>	Vehicle identification time-out	–
<b>4326</b> <b>(red indicator lamp)</b>	Illegal ID request via CAN	–
<b>4337</b> <b>(red indicator lamp)</b>	General EEPROM error	Replace TCU.
<b>4338</b> <b>(red indicator lamp)</b>	Configuration error	Program the correct configuration for the new vehicle.
<b>4339</b> <b>(red indicator lamp)</b>	Application error (ZF internal)	Replace TCU.
<b>4341</b> <b>(red indicator lamp)</b>	Coupling calibration error	Calibrate transmission couplings as instructed.
<b>4342</b> <b>(yellow indicator lamp)</b>	Coupling configuration data lost	Calibrate transmission couplings as instructed.
<b>4344</b> <b>(yellow indicator lamp)</b>	Implausible request of gear restriction	Check FWD controller. Check CAN wire. Check unit configuration.
<b>4345</b> <b>(yellow indicator lamp)</b>	TCU receiving FWD CAN messages although configuration indicates no FWD controller installed	Check unit configuration.
<b>4346</b> <b>(yellow indicator lamp)</b>	Time-out error on “gear range selection” message from FWD controller	Check CAN wire. Check FWD controller.
<b>4347</b> <b>(yellow indicator lamp)</b>	Time-out error on “FWD status” message from FWD controller	Check CAN wire. Check FWD controller.
<b>4348</b> <b>(yellow indicator lamp)</b>	CAN “FWD status” message contains invalid data	Stop operation.
<b>4349</b> <b>(yellow indicator lamp)</b>	Short circuit to ground at DLM output	Code possible only if additional ZF diagnosis module connected to TCU.
<b>4350</b> <b>(yellow indicator lamp)</b>	Short circuit on battery + at DLM output	Code possible only if additional ZF diagnosis module connected to TCU.
<b>4351</b> <b>(yellow indicator lamp)</b>	Short circuit on battery + at DLM warning lamp	Code possible only if additional ZF diagnosis module connected to TCU.
<b>4352</b> <b>(yellow indicator lamp)</b>	Open circuit at DLM warning lamp	Code possible only if additional ZF diagnosis module connected to TCU.

## Gearbox - Troubleshooting

<b>Problem</b>	<b>Possible Cause</b>	<b>Correction</b>
<b>Gearshift pressure too low in all gears, indicator lamp lights up</b>	The oil level is too low.	Top up oil.
	The converter pump is defective.	Contact your authorized dealer.
	The shift pressure valve is defective.	Contact your authorized dealer.
	The pressure control valve is defective.	Contact your authorized dealer.
<b>Gearshift pressure too low in individual gears</b>	The gearbox control spool is defective.	Contact your authorized dealer.
	The sealing rings on the respective gear couplings are worn.	Contact your authorized dealer.
<b>Converter oil temperature too high</b>	The oil level is too high.	Reduce oil.
	The oil level is too low.	Top up oil.
	The converter safety valve is defective.	Contact your authorized dealer.
	The gearbox oil cooler is contaminated.	Clean the gearbox oil cooler.
	The wrong gear is selected.	Check which gear is selected.
<b>No response in all gears</b>	The oil level is too low.	Top up oil.
	The converter pump is defective.	Contact your authorized dealer.
	The shift pressure valve is defective.	Contact your authorized dealer.
	The pressure control valve is defective.	Contact your authorized dealer.
	The gearbox control spool is defective.	Contact your authorized dealer.
	The engine/converter connection is defective.	Contact your authorized dealer.
	The solenoid valves in gearbox control spool is defective.	Contact your authorized dealer.
	There is a fault in the electrical system.	Contact your authorized dealer.
<b>No response in individual gears</b>	The solenoid valves in the gearbox control spool are defective.	Contact your authorized dealer.
	There is a fault in the electrical system.	Contact your authorized dealer.
<b>Indicator lamp remains on, gearshift pressure OK</b>	The gearshift pressure switch is defective.	Contact your authorized dealer.
	There is a fault in the electrical system.	Contact your authorized dealer.

## Weights

<b>Types</b>	<b>F106.7</b>	<b>F106.7A</b>	<b>F156.7</b>	<b>F156.7A</b>
Basic machine without equipment and additional weights	<b>10791 kg (23790 lb)</b>	<b>11091 kg (24451 lb)</b>	<b>13669 kg (30135 lb)</b>	<b>14069 kg (31017 lb)</b>
Front axle weight	<b>2549 kg (5620 lb)</b>	<b>2649 kg (5840 lb)</b>	<b>3428 kg (7557 lb)</b>	<b>3528 kg (7778 lb)</b>
Rear axle weight	<b>8242 kg (18170 lb)</b>	<b>8442 kg (18611 lb)</b>	<b>10241 kg (22578 lb)</b>	<b>10541 kg (23239 lb)</b>
Basic machine with dozer and rear weight	<b>11690 kg (25772 lb)</b>	<b>11990 kg (26433 lb)</b>	<b>14849 kg (32736 lb)</b>	<b>15250 kg (33620 lb)</b>
Front axle weight	<b>3198 kg (7050 lb)</b>	<b>3298 kg (7271 lb)</b>	<b>4446 kg (9802 lb)</b>	<b>4546 kg (10022 lb)</b>
Rear axle weight	<b>8492 kg (18722 lb)</b>	<b>8692 kg (19163 lb)</b>	<b>10404 kg (22937 lb)</b>	<b>10704 kg (23598 lb)</b>
Basic machine with dozer and rear ripper, 5 teeth with protection sheet	<b>11994 kg (26442 lb)</b>	<b>12290 kg (27095 lb)</b>	<b>15280 kg (33687 lb)</b>	<b>15680 kg (34568 lb)</b>
Front axle weight	<b>3090 kg (6812 lb)</b>	<b>3190 kg (7033 lb)</b>	<b>4300 kg (9480 lb)</b>	<b>4400 kg (9700 lb)</b>
Rear axle weight	<b>8900 kg (19621 lb)</b>	<b>9100 kg (20062 lb)</b>	<b>10980 kg (24207 lb)</b>	<b>11280 kg (24868 lb)</b>
Basic machine with front weight and rear weight	<b>11586 kg (25543 lb)</b>	<b>11890 kg (26213 lb)</b>	<b>14685 kg (32375 lb)</b>	<b>15080 kg (33246 lb)</b>
Front axle weight	<b>3074 kg (6777 lb)</b>	<b>3174 kg (6997 lb)</b>	<b>4253 kg (9376 lb)</b>	<b>4353 kg (9597 lb)</b>
Rear axle weight	<b>8516 kg (18775 lb)</b>	<b>8716 kg (19215 lb)</b>	<b>10427 kg (22988 lb)</b>	<b>10727 kg (23649 lb)</b>
Basic machine with front weight and rear ripper, 5 teeth with protection sheet	<b>11890 kg (26213 lb)</b>	<b>12190 kg (26874 lb)</b>	<b>15116 kg (33325 lb)</b>	<b>15520 kg (34216 lb)</b>
Front axle weight	<b>2970 kg (6548 lb)</b>	<b>3070 kg (6768 lb)</b>	<b>4107 kg (9054 lb)</b>	<b>4207 kg (9275 lb)</b>
Rear axle weight	<b>8920 kg (19665 lb)</b>	<b>9120 kg (20106 lb)</b>	<b>11013 kg (24280 lb)</b>	<b>11313 kg (24941 lb)</b>
Max. operating weight total	<b>12200 kg (26896 lb)</b>	<b>12500 kg (27558 lb)</b>	<b>16100 kg (35494 lb)</b>	<b>16500 kg (36376 lb)</b>
Max. operating weight front axle	<b>3700 kg (8157 lb)</b>	<b>3800 kg (8378 lb)</b>	<b>5100 kg (11244 lb)</b>	<b>5200 kg (11464 lb)</b>
Max. operating weight rear axle	<b>9000 kg (19842 lb)</b>	<b>9200 kg (20283 lb)</b>	<b>11300 kg (24912 lb)</b>	<b>11700 kg (25794 lb)</b>

**III. Oils for powershift transmissions with Ergopower**

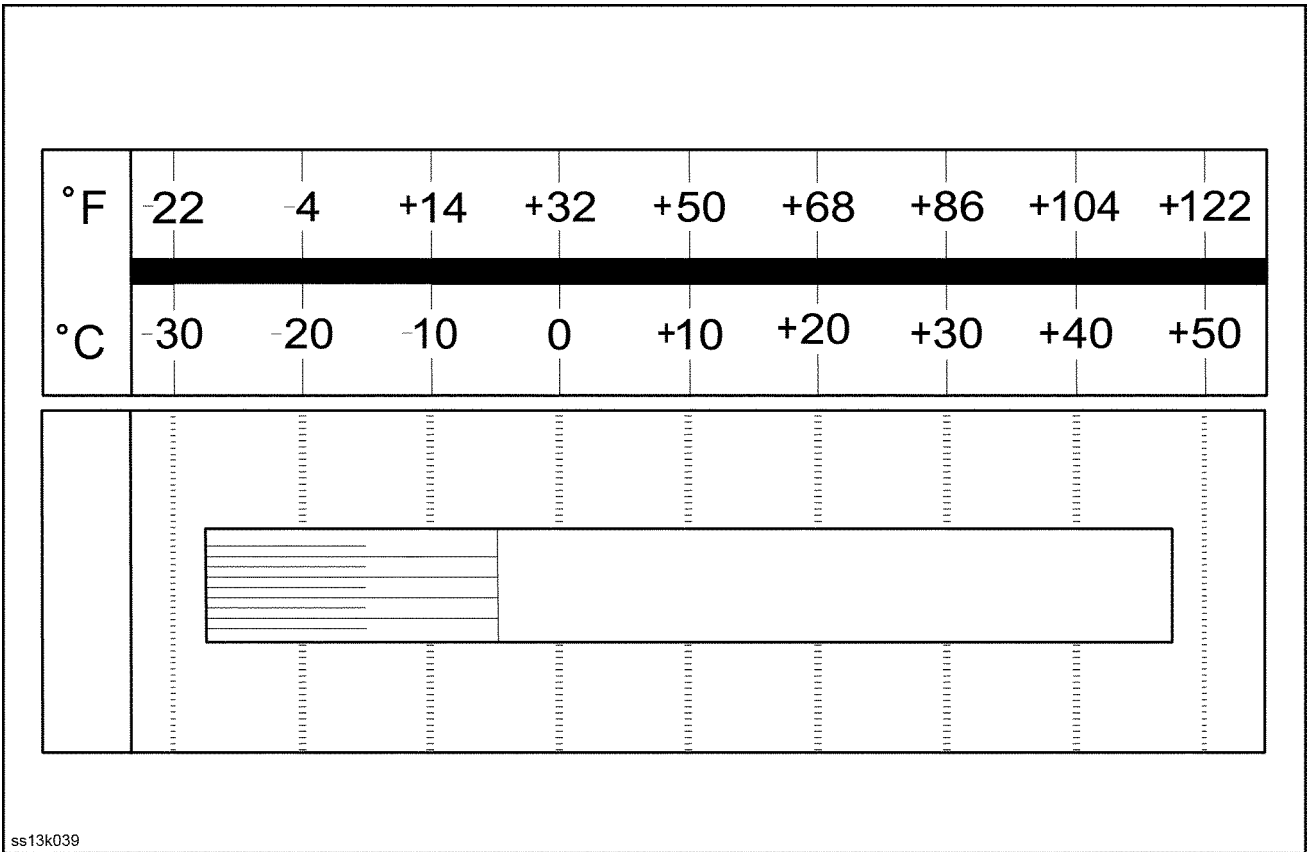

ss13k039

SS13K039 4

Specification:

- API: CI-4
- ACEA: E7

API: American Petroleum Institute

ACEA: Association des Constructeurs Européen d'Automobiles g.i.e.

**Oils**

SAE 15W-40 (NH 330 H)

e.g.: AMBRA MASTERGOLD HSP 15W-40



Automatic powershift transmission-preheating.

CLICK HERE TO **DOWNLOAD** THE COMPLETE MANUAL

- Thank you very much for reading the preview of the manual.
- You can download the complete manual from: [www.heydownloads.com](http://www.heydownloads.com) by clicking the link below



- Please note: If there is no response to CLICKING the link, please download this PDF first and then click on it.

CLICK HERE TO **DOWNLOAD** THE COMPLETE MANUAL