

OPERATOR'S MANUAL

E35B Tier 4 Compact Crawler Excavator

PIN PX15 - and higher

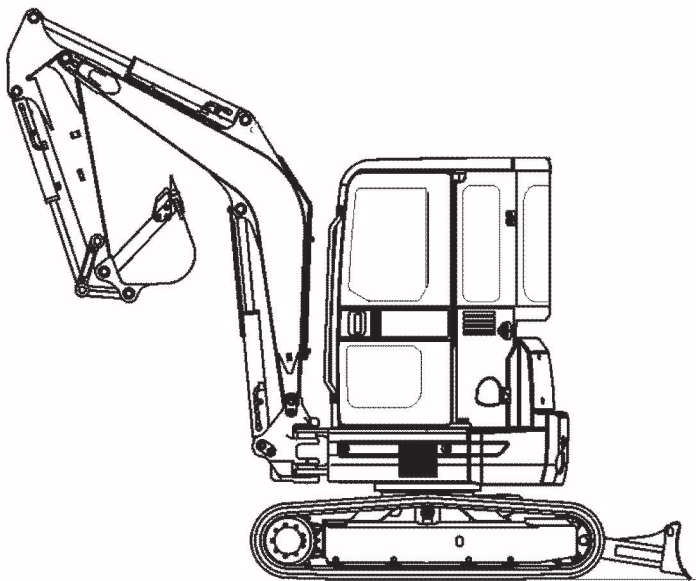

Part number S2PX00040ZE01

1st edition English
June 2010



CLICK HERE TO **DOWNLOAD** THE COMPLETE MANUAL

- Thank you very much for reading the preview of the manual.
- You can download the complete manual from: www.heydownloads.com by clicking the link below



- Please note: If there is no response to CLICKING the link, please download this PDF first and then click on it.

CLICK HERE TO **DOWNLOAD** THE COMPLETE MANUAL

FOPS, ROPS CERTIFICATION

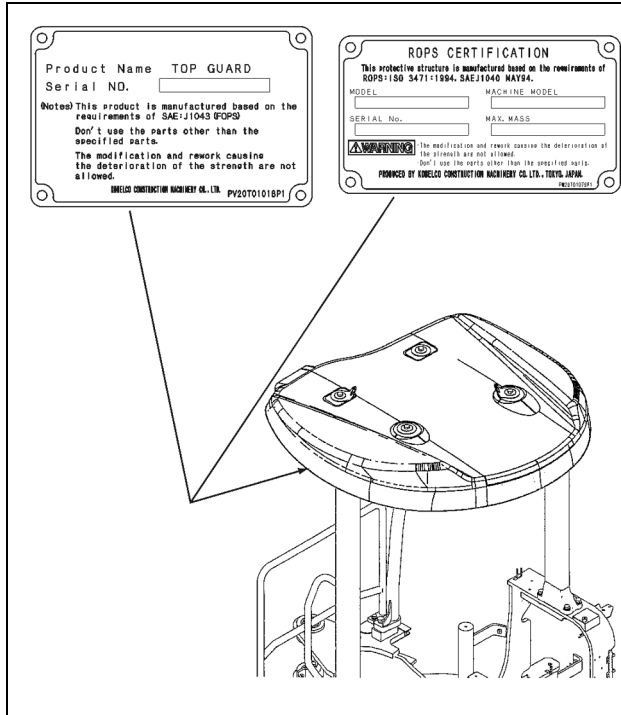

BS07M603

Figure 5

FOPS (Falling Object Protection)	
➤ _____	Make and Model
➤ _____	Serial Number

ROPS (Roll Over Protection)	
➤ _____	Make and Model
➤ _____	Serial Number

FIRE EXTINGUISHER

It is recommended that you have a fire extinguisher on your machine. Contact your dealer for the type and location of a fire extinguisher on this machine.

FIRE PREVENTION

Remove all trash or debris from the machine each day. Check the engine area and exhaust system

SEAT BELT PRECAUTIONS

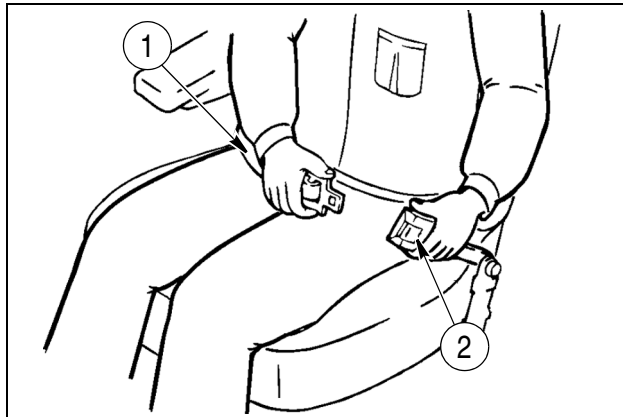

BC02N375

Figure 5

- 1. RIGHT HAND BELT STRAP
- 2. LATCH MECHANISM

1. Insert the metal end of the right-hand belt strap into the latch mechanism on the left-hand side of the seat.
2. To unlatch the seat belt, press the red button on the left-hand side latch mechanism.

⚠ WARNING ⚠

Before starting the engine make certain seat belts are securely fastened. The seat belt can help insure your safety if it is used and properly maintained. Never wear a seat belt loosely or with slack in the belt system. Never wear the belt in a twisted condition or pinched between the seat structural members.

M422A

EMERGENCY EXIT HAMMER

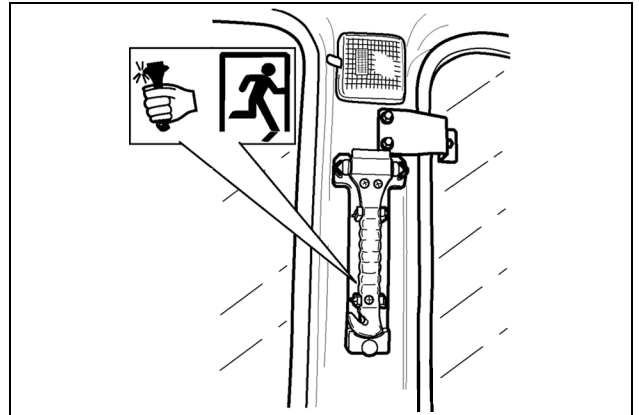

DC04D572

Figure 6

An emergency exit hammer is provided on the right side of cab. In case of emergency, take the emergency hammer, break the cab glass, and escape from the cab. In addition, the emergency hammer is equipped with a cutter on the lever side to cut seat belt, etc.

SPECIFIC PRECAUTIONS TO THIS MACHINE

- Keep the load or tool as low as possible while moving the machine around the job site.
- Never smoke while refueling.
- Do not use tractive force of the machine for loading the bucket attachment nor to push or pull any objects.
- Do not use swinging force of the machine for operations.
- Do not perform “hammering” operation with the bucket.
- Do not use this machine for anything other than its intended purpose.
- DO NOT OPERATE bucket and arm cylinders to stroke end repeatedly.
- Do not over exert the machine’s capacities.
- Never pull standing objects toward the machine.
- Do not use the long reach attachment for general construction work at any time.

SEAT BELT - WARNING

Located on seat stand cover- Part Number PE20T01027P1

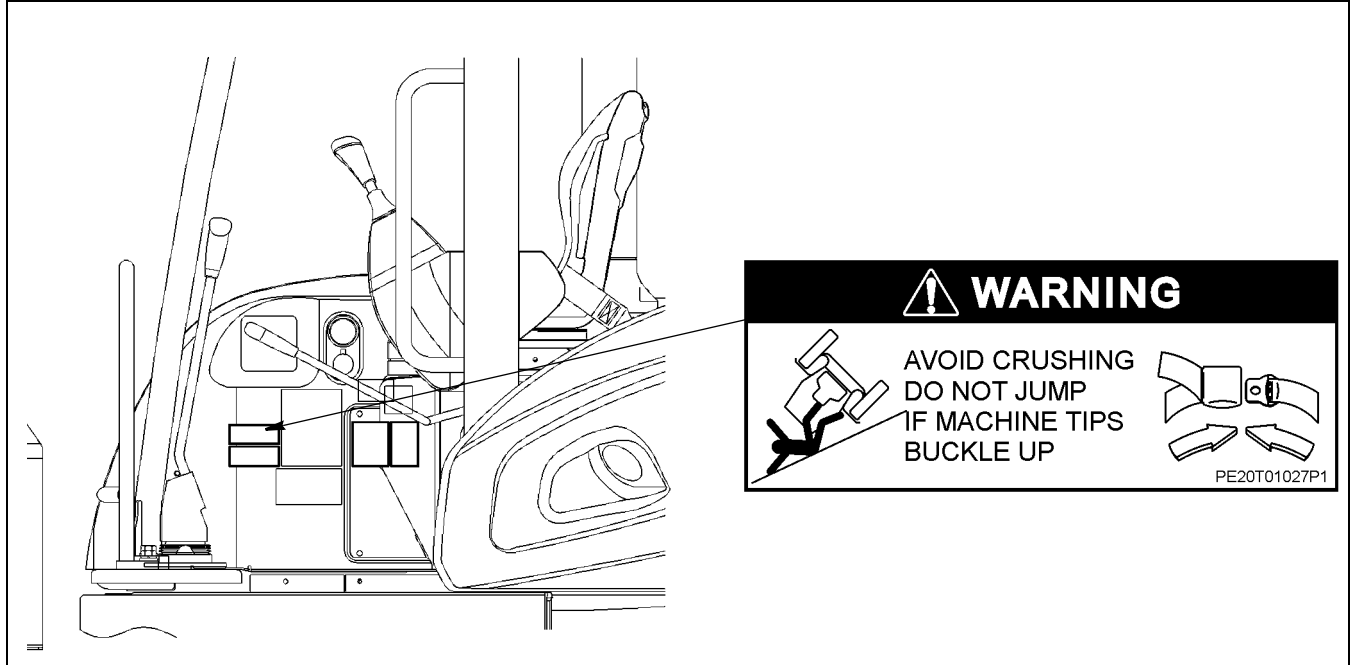

BS07M607/UPX00100019E01

Figure 23

WINDOW LOCK - CAUTION

Located on inside front window- Part Number YN20T01416P1

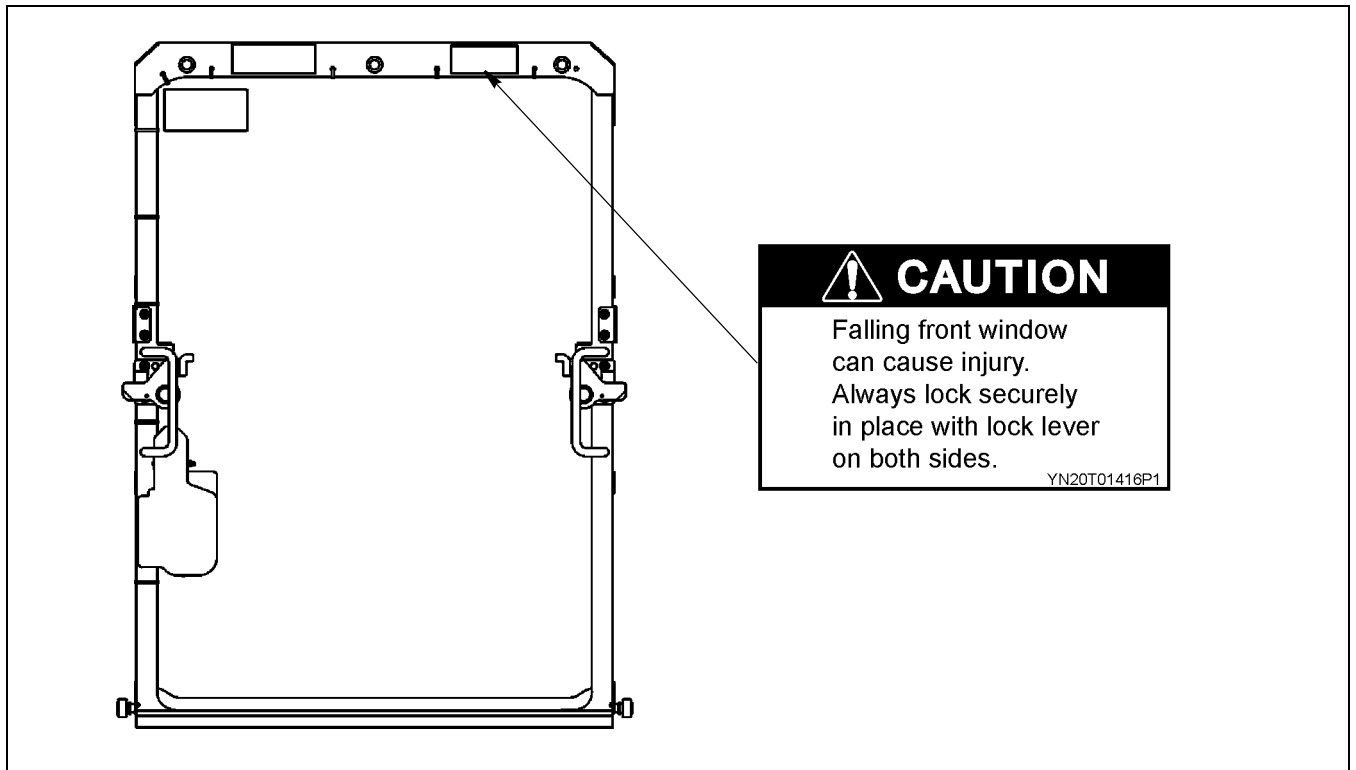

BS07M655/UPX00100026E01

Figure 24

CHAPTER 3
INSTRUMENTS AND CONTROLS
TABLE OF CONTENTS

OPERATOR CAB AND OPERATOR SEAT	3-3
Locking/Unlocking Cab Door	3-3
Cab Door Latch	3-3
Opening and Closing Windshield	3-4
Removing and Storing Lower Front Window	3-4
Opening Right Window Glass	3-4
Cab Dome Light	3-5
Document Pouch	3-5
Operator Seat Adjustments	3-6
Seat Belt	3-6
MACHINE ACCESS COMPARTMENTS AND DOORS	3-7
Engine door Cover	3-7
Window Washer Tank	3-7
OPERATOR'S COMPARTMENT CONTROLS AND ACCESSORIES	3-8
components	3-8
Operator Cab Nomenclature	3-9
Components & Controls	3-9
Hour Meter	3-9
Right Hand Console and Monitor	3-9
Key Switch	3-9
Monitor	3-10
Gauges	3-10
Warning Lamps	3-11
Switches	3-12
Levers and Pedals	3-16
Hydraulic Safety Lock Lever	3-16
Operating Control Levers	3-17
Left Hand Operator Control Lever (ISO/SAE Pattern)	3-17
BHL Pattern	3-18
Right Hand Operator Control Lever (ISO/SAE Pattern)	3-18
Pattern Control Change (BHL Pattern)	3-19
Left Hand Operator Control Lever (BHL Pattern)	3-20
Right Hand Operator Control Lever (BHL Pattern)	3-20
Left and Right Travel Levers and Pedals	3-21
Throttle Control Lever	3-21
Dozer Control Lever	3-22
Boom Swing Operating Pedal	3-22

WARNING LAMPS

NOTE: If warning lamps illuminate, change machine operating method immediately. If this lamp remains illuminated, stop the engine and determine the cause of the problem. See the Maintenance Section - Chapter 6 in this manual or contact your dealer.

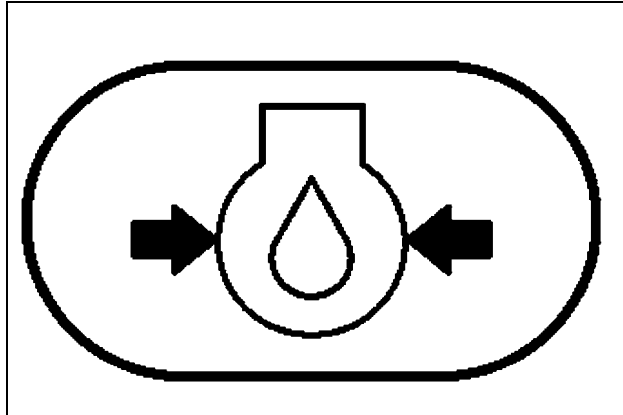

BS07M776

Figure 22

ENGINE OIL PRESSURE LAMP (RED)

The engine oil pressure lamp (3) will illuminate if the engine oil pressure drops abnormally while the engine is running. Stop the engine immediately and check engine oil.

See the Maintenance Section- Chapter 6 for checking oil level.

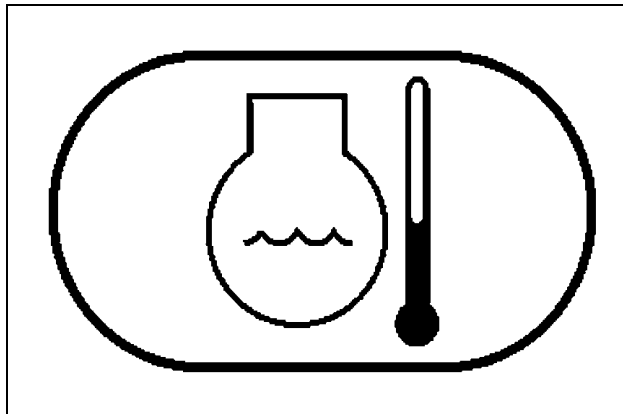

BS07M777

Figure 23

COOLANT TEMPERATURE LAMP (RED)

If the coolant temperature rises abnormally, the coolant temperature lamp (4) will illuminate. Run the machine at low idle until the coolant temperature drops to a normal range.

Reduce engine RPM to idle, and stop operation until engine coolant temperature reaches a safe operating temperature range.

See the Maintenance Section - Chapter 6 for checking coolant level.

WARNING

Do not perform any maintenance on a hot engine. Allow the engine to cool before inspection or maintenance. Failure to comply could result in death or serious injury.

M1393

WARNING

Improper service or repair can cause injury or death. If you do not understand the service procedures for this machine, see your dealer or the service manual for this machine. Failure to comply could result in death or serious injury.

M84-102

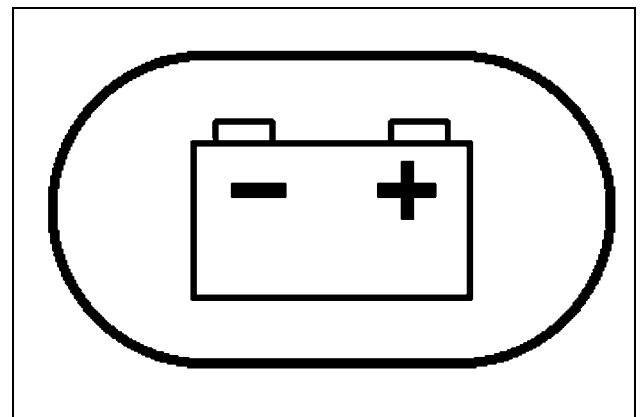

BS07M779

Figure 24

BATTERY CHARGE LAMP (RED)

The battery charge lamp (5) will illuminate if the charging system is experiencing a malfunction. This lamp will illuminate briefly when the engine is turned on and should turn off once the engine is running. Check the charging system if this indicator remains illuminated after the engine has started.

PATTERN CONTROL CHANGE (BHL PATTERN)

To change the machine's control pattern from ISO (SAE) to (BHL) pattern, proceed as follows:

1. Place the attachment on the ground, throttle control in low idle, and turn the key switch off.

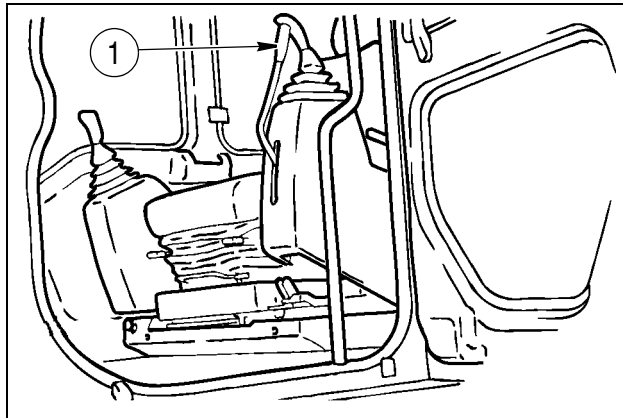

DC04C344 Figure 43

1. HYDRAULIC SAFETY LOCK LEVER IN LOCKED (UP) POSITION

2. Place the hydraulic safety lock lever in the lock (UP) position before leaving the cab.

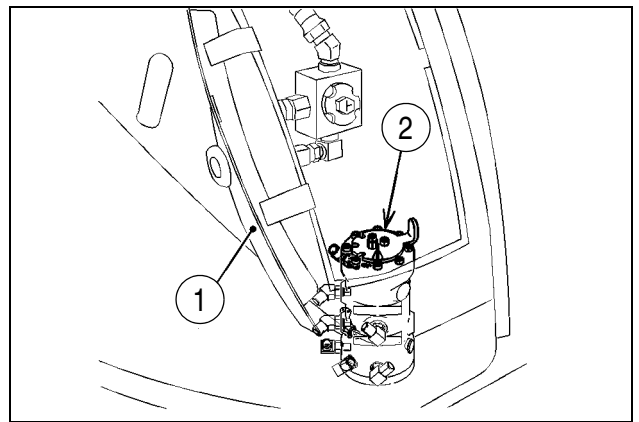

BS07N621

Figure 44

1. PATTERN CHANGER VALVE

3. Open the right compartment door, locate the pattern changer lever (2).

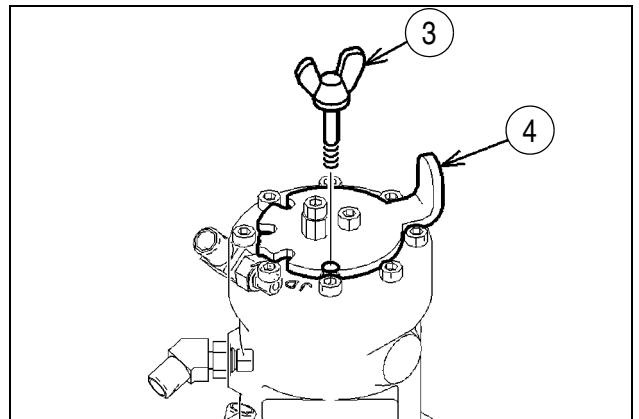

BS07N564

Figure 45

4. Loosen wing bolt (3), and change the lever position to the desired pattern.
5. Hand tighten the wing bolt (3) securely. Do not use tools to tighten.
6. Close compartment cover.
7. Carefully operate the control levers to make certain functions match the pattern selected. Practice in an open area to become familiar with the new pattern.

⚠ WARNING ⚠

Check machine's control pattern for conformance to pattern on decal-card in cab. If pattern does not match decal-card on cab door holder, flip decal-card on holder to match the machine's control pattern before operating machine. Failure to comply could result in injury or death.

Warming Hydraulic Oil

NOTICE: Check clearance between bucket and cab before operation. Slowly cycle bucket, check for interference with arm and cab, particularly if a lifting eye is welded on bucket bottom. Exercise care when operating the bucket near the cab.

- a. Move throttle control to HI idle position.

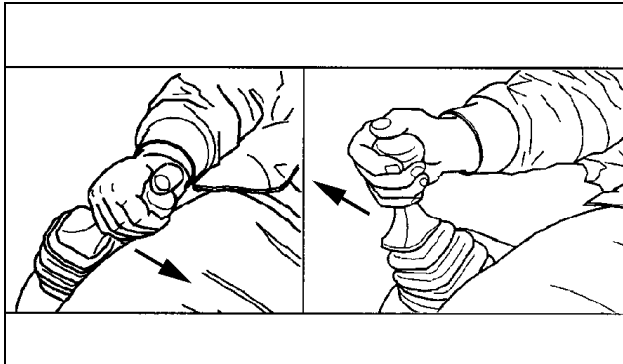

DC04D473

Figure 5

- b. Perform bucket dig operation and hold over relief for 10 to 15 seconds, then operate bucket dump and hold over relief for 10 to 15 seconds. Repeat the operations for 5 to 10 minutes.

- c. Move throttle control to mid position.

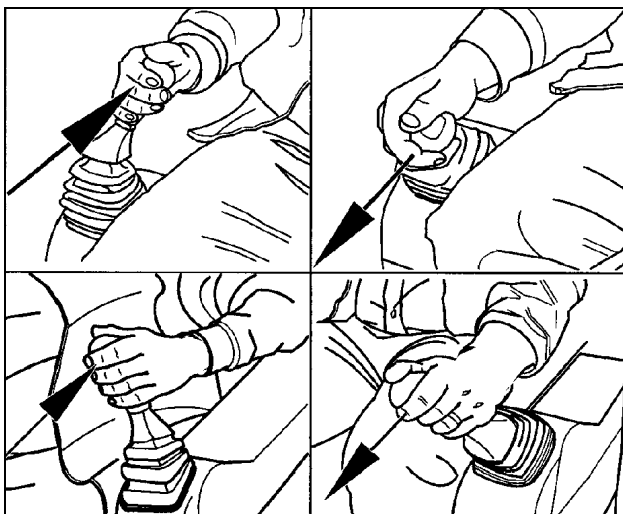

DC04D474

Figure 6

- d. Operate the boom and arm controls for 5 to 10 minutes each.

⚠ WARNING ⚠

While operating the machine with cold hydraulic oil, the operator may experience slow or unexpected movement of functions. Damage to the hydraulic components may result due to the cold oil not providing adequate lubrication.

Auto warm up should be utilized whenever machine is started in temperatures below 10°C (50°F) to stabilize machine control response. Cold oil can cause erratic machine operation. Failure to comply could result in death or serious injury.

M1715

USING THE DOZER

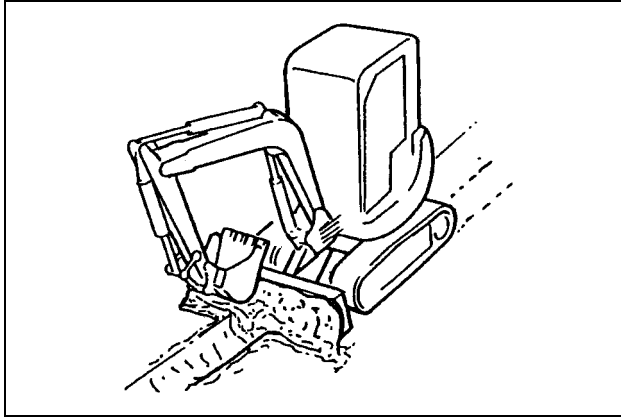

BS07M856

Figure 35

For back filling and leveling work after digging, use the dozer to push the soil back into the ditch or to level ground.

Do not push or pull material with the bucket like a bulldozer when using the machine to level material.

1. Scrape the soil at its upper surface with the dozer.
2. Use the dozer to back fill a trench.
3. Adjust the height of dozer with the dozer control lever to avoid over loading the engine.
4. Never travel with front attachment touching the ground. Severe structural damage could occur.

LOADING

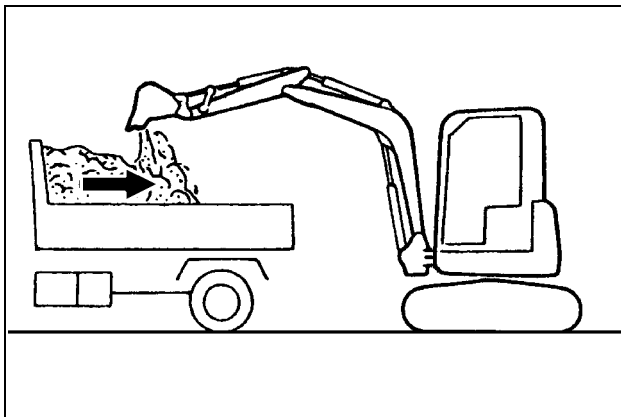

BS07M857

Figure 36

1. Operating efficiency can be improved by positioning the dump truck so the swing distance is kept to a minimum. Always have a good field of view.
2. Start at the front side of the dump body and work toward the back.

OFFSET DIGGING

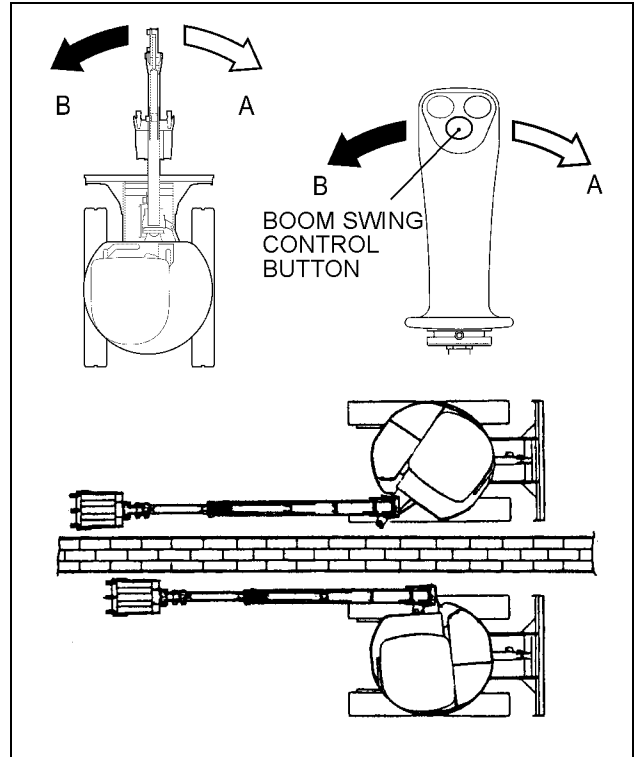

BS07M858

Figure 37

To operate the boom swing function, press the button on the top of the left control lever. Operate the control lever to the left for left boom swing or right for right boom swing.

NOTICE: While the boom swing control function is engaged, the boom will continue to swing when the finger is removed from boom swing control button. To cancel the boom swing function, return the left control handle back to the neutral position.

⚠ WARNING ⚠

Check all controls and safety devices in a safe, open area before starting work. Failure to comply could result in injury or death.

M1088

CLICK HERE TO **DOWNLOAD** THE COMPLETE MANUAL

- Thank you very much for reading the preview of the manual.
- You can download the complete manual from: www.heydownloads.com by clicking the link below



- Please note: If there is no response to CLICKING the link, please download this PDF first and then click on it.

CLICK HERE TO **DOWNLOAD** THE COMPLETE MANUAL

OPTIONAL HAND CONTROL

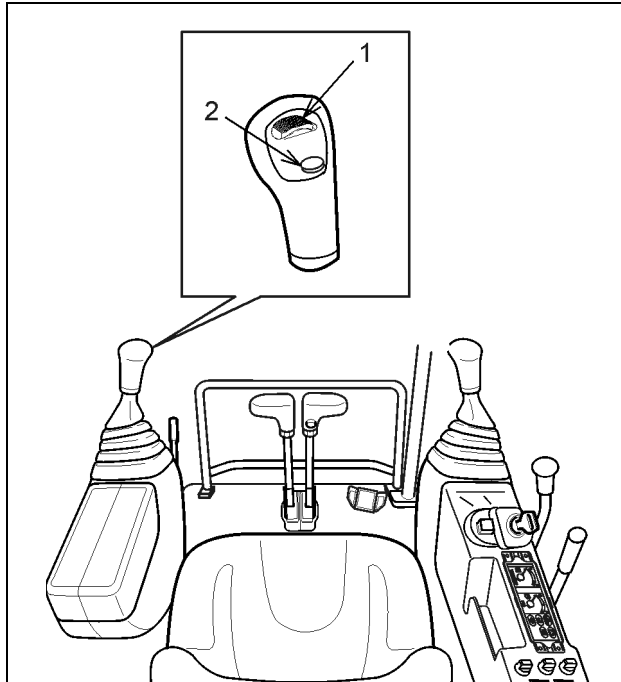

BS08J521

Figure 49

1. SLIDE (TURN ATTACHMENT) SWITCH
2. HORN

Buttons are provided on the grip of the left control lever handle as an optional feature. Check the function of the left control handle buttons before operating the machine.

- a. Move throttle control to HI idle position.
- b. Using boom, arm and bucket controls set the breaker or nibbler to desired position.
- c. Use the boom, arm, and bucket controls to position the attachment.
- d. Sliding switch (1) will turn the attachment right or left.
 - Slide left - attachment turns to left
 - Slide right - attachment turns to right

NOTICE: Hydraulic flow will increase depending upon the slide distance of the switch (1).

WARNING

To help prevent personal injuries during operation and maintenance, use safety shoes, a hard hat, safety glasses or goggles and good fitting clothing. Failure to comply could result in death or serious injury.

M110B

WARNING

Do not attempt to operate or service this machine unless you have first read and perfectly understood the safety messages and instructions appearing in this manual. Failure to comply could result in death or serious injury.

M1087

NOTICE: Operation of Breaker or Nibbler longer than one (1) minute intervals could cause premature wear or damage to the attachment and the machine. If material is not breaking, reposition breaker or nibbler and repeat operation in one (1) minute intervals.

ACCELERATE SERVICE INTERVALS

Contamination and deterioration of hydraulic oil may cause function problems with control valves, early wear and possible seizure of the hydraulic pump. The operation of breakers and/or nibblers accelerates the deterioration of hydraulic oil compared to normal earth moving operations with a bucket. Replace filters and hydraulic oil more frequently.

FLUIDS AND FILTERS

REQUIRED FLUIDS/LUBRICANTS AND CAPACITIES

ENGINE

Type of Oil Engine Oil SAE 15W30

Capacity:

Engine Oil with filter change . . 6.7 liters (1.8 gal)

NOTICE: See **ENGINE OIL LEVEL** in Chapter 6 for proper oil filling and/or checking engine oil level.

HYDRAULIC

Type of Oil Hydraulic Oil AW 46

Capacity:

Hydraulic Tank.38 liters (10.0 gal)

Hydraulic System48 liters (12.7 gal)

NOTICE:

1. See **HYDRAULIC OIL LEVEL** in Chapter 6 for proper filling and/or checking hydraulic oil level.

TRAVEL MOTOR REDUCTION UNIT

Type of Oil SAE 90 GL4 Gear Oil

Capacity 0.7 liters (0.18 gal) Each x 2

NOTICE: See **TRAVEL MOTORS REDUCTION UNIT OIL** in Chapter 6 for proper filling and/or checking oil level.

UPPER ROLLERS

Type of Oil SAE 90 GL4 Gear Oil

Capacity45 cc (2.7 cu. in.) Each

IDLERS

Type of Oil SAE 90 GL4 Gear Oil

Capacity 80 cc (4.8 cu. in.) Each

OPERATING LEVER JOINT

Type of Oil EP Grease EP/2

CapacityAs required in each joint

NOTICE: See **CONTROL LEVER JOINT LUBRICATION** in chapter 6 for proper lubrications.

UPPER ATTACHMENT PINS

Type of Oil EP Grease EP/2

CapacityAs required in each pin

NOTICE: See **ATTACHMENT LUBRICATION** in Chapter 6 for proper lubrications.

SWING BEARING

Type of Oil EP Grease EP/2

Capacity . . .As required (1 place - swing 90° x 4)

NOTICE: See **SWING BEARING LUBRICATION** in Chapter 6 for proper lubrication.

TRACK TENSION ADJUSTMENT

Type of Oil EP Grease EP/2

Capacity As required (2 places)

NOTICE: See **TRACK TENSION** in Chapter 6 for proper procedures in injecting grease.

RADIATOR

Coolant Ethylene-glycol Coolant Solution

ENGINE COOLANT MIXTURE	
Expected Minimum Temp.	Long Life Coolant
-14.5°C (5.9°F)	30% mixed
-34°C (-29.2°F)	50% mixed

Capacity:

Radiator1.6 liters (0.42 gal)

Cooling System4.6 liters (1.22 gal)

NOTICE: See **ENGINE COOLANT CHANGE** in Chapter 6 for proper coolant filling and/or coolant level check.

FUEL TANK

Type of Fuel Diesel Fuel grade No. 2

Capacity Fuel Tank - 38 liters (10 gal)

NOTICE: See **FUEL LEVEL** in Chapter 6 for proper filling and/or checking the fuel level.

WARM ENGINE OIL

Engine should have a temperature between 20°C - 40°C (68°F - 104°F) before the oil is changed. If necessary, run engine until the oil is warm within the recommended oil change temperature.

TAG-OUT MACHINE



DC04B671

Figure 4

Before beginning any inspection or maintenance procedures, secure a DO NOT OPERATE tag to the operator's console to inform the operator that the machine will be inoperable for inspection and maintenance. This tag will help prevent accidental starting of the machine.

INSPECT WASTE OILS AND FILTERS

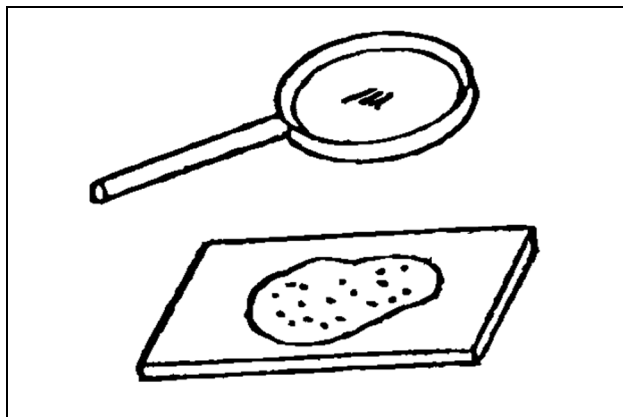

DC04B672

Figure 5

Before disposal, inspect all waste oils, fluids, and filters for debris and foreign material. Cut open the oil filters to determine any abnormal wear.

PREVENT CONTAMINATION

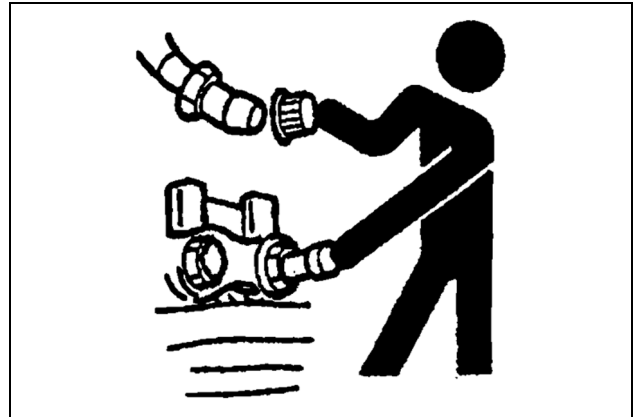

DC04B673

Figure 6

Always cap or plug lines when hydraulic components are removed to help prevent hydraulic system contamination that can be caused by dirt, dust, and debris entering a line or port.

NOTICE: Never allow a hydraulic line or component to become contaminated. Always use proper caps and plugs.

SEALS AND O-RINGS

Always replace seals and O-rings with new parts. Never reuse a seal or O-ring during reassembly of components. Make sure to lubricate all new seals with the appropriate oil before installation.

STOP ENGINE

DO NOT attempt any maintenance with engine running. Always stop the engine and allow machine to cool.

WEAR SAFETY EQUIPMENT

Wear hard hat, safety goggles or face shield, work gloves, safety shoes, and well fitting work clothes when performing inspection and maintenance procedures on this machine.

CLEANING PARTS

Use only approved cleaning solvents and proper equipment to clean parts.

————— **⚠ WARNING ⚠** —————

Never use gasoline, diesel fuel or other flammable solvents to clean parts. Always clean parts in a well ventilated area. Failure to comply could result in death or serious injury.

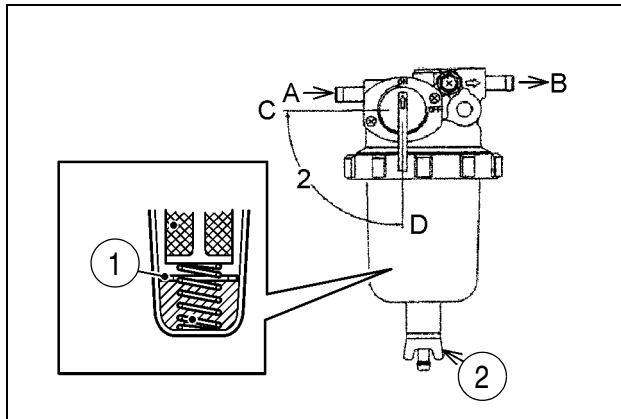
DRAIN WATER SEPARATOR

BS07N030

Figure 19

1. Inspect water separator every 8 hours. Drain and clean at 500 hours.
2. Visually inspect separator. If red ring (1) sinks to bottom of case, no water is present.
3. When ring is floating, drain water and sediment.
4. Open valve (2) and drain until clean fuel is discharged.
5. Repair or replace damaged hoses and lines before any operation.

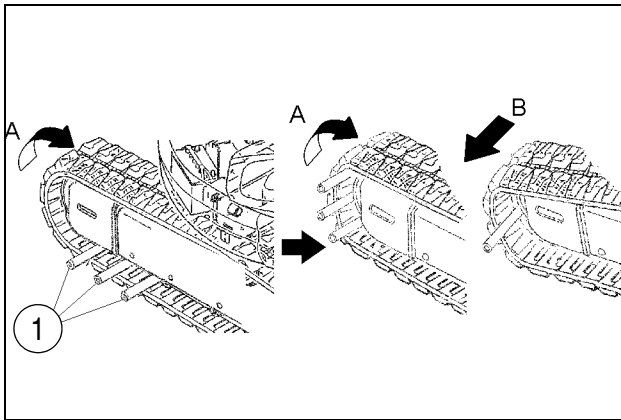

BS07N049

Figure 44

3. Insert three steel pipes into the bottom front rubber crawler belt, then slowly rotate the sprocket backward by moving the track.
4. Stop the rotation when the rubber crawler belt separates from the idler wheel. Shut off the engine.
5. Slide the crawler belt over the steel pipes to remove.

Replacing the Rubber Crawler Belt

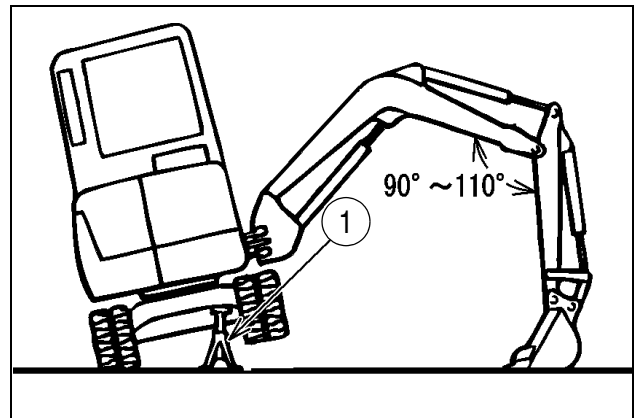

BS07N042

Figure 45

1. Keep all unauthorized personnel clear of the area. Park the machine on a hard, level surface. Move the upper structure at a $90^{\circ} \sim 110^{\circ}$ to the crawler frame. Operate the attachment placing it on the ground as illustrated and gradually lower the boom to lift one side of the machine. Shut off the engine. Support the lower travel structure with a safety support (1).

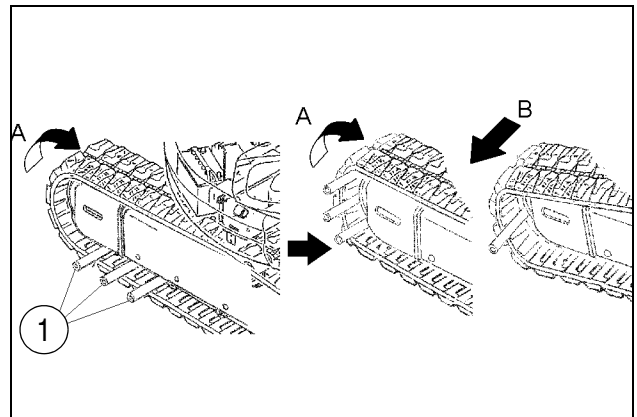

BS07N049

Figure 46

2. Engage the rubber crawler belt with the sprocket and hang it on the idler.
3. Insert three steel pipes into the bottom front rubber crawler belt then slowly rotate the sprocket backward. When the rubber crawler belt separates from the idler wheel, stop the rotation. Shut off the engine.
4. Slide the rubber crawler belt over the steel pipes to install it.

CLEANING AND REPLACING ENGINE AIR FILTER

Clean the air filter element every 250 hours. After cleaning six times or at six month intervals, the element should be replaced at 500 hours. If any damage is visible to the filter, replace it regardless of machine time or scheduled maintenance.

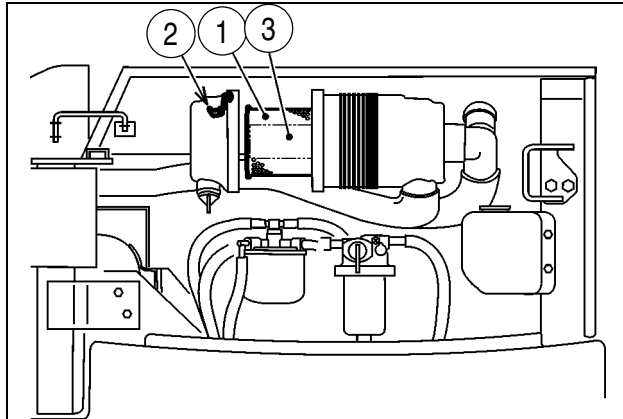

BS07N637

Figure 70

NOTICE: When cleaning outer element, do not remove inner element to prevent dust from entering the air intake.

1. Release the two clamps (2) from the air cleaner cover. Remove the air cleaner outer element (1) from the housing.
2. Clean the inside of air cleaner housing.

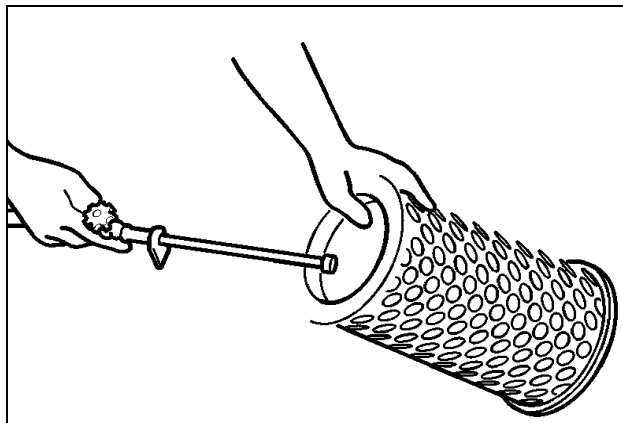

BS07N132

Figure 71

3. To clean the outer element (1), blow compressed air (less than 0.3 MPa {43 psi}) up and down along the folds of the filter element interior to remove clogged dust or other contaminants.
4. After cleaning, use a light to check the inside of the element for tearing, pinholes, or packing damage. Replace with a new element every 500 hours or anytime damage is evident.
5. Set outer element (1) in the housing.
6. Install the cover on two clamp (2) positions, directing the mark "TOP" on the cover to the inlet side

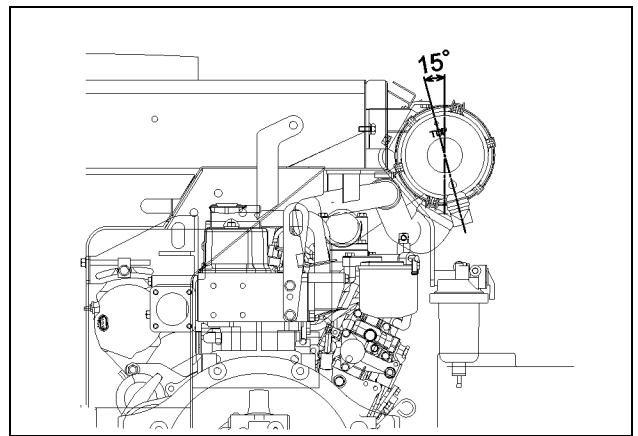

BS07N664

Figure 72

7. The TOP position mark should face up. Make certain to avoid interference with the intake hose. Incline the air filter casing approximately 15° to the engine side.

REPLACING THE INNER ELEMENT (IF EQUIPPED)

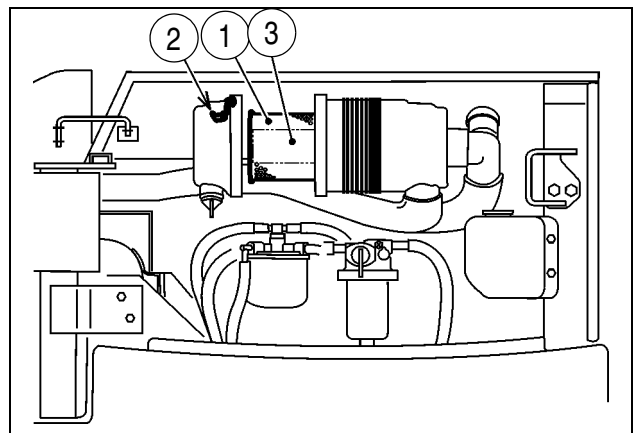

BS07N131

Figure 73

8. The inner element is an optional part. To replace, remove the inner element (3).
9. Install new inner element (3) and outer element (1). Replace cover. Make certain the O-ring seal is correctly positioned.

NOTICE: For machines equipped with double elements, the inner element must be replaced together with the outer element. Do not clean inner element. Replace only with a new element.

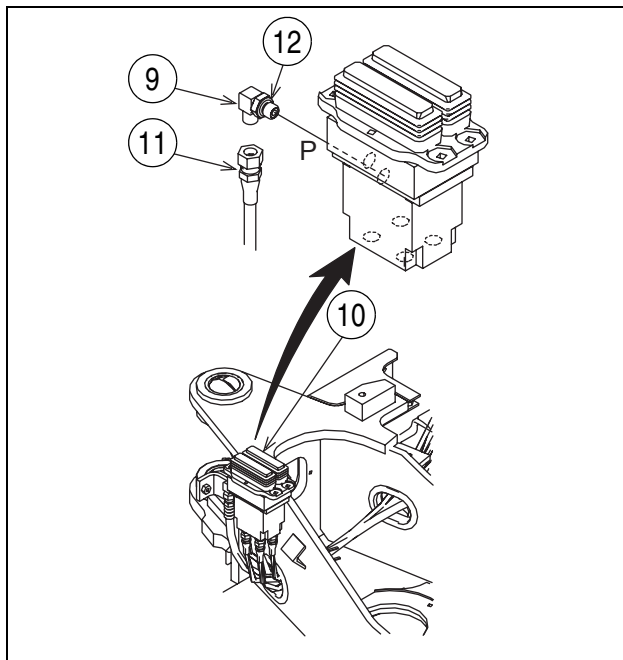

UPW00400107J01

Figure 90

16. Remove the elbow with filter (9) of pilot valve (10) for cleaning.
17. Remove the floor mat and floor plate. Disconnect the hose (11) connected to P port on the pilot valve (10). Remove the elbow (9). After removal, put a plug into the bore to prevent entry of foreign matter.

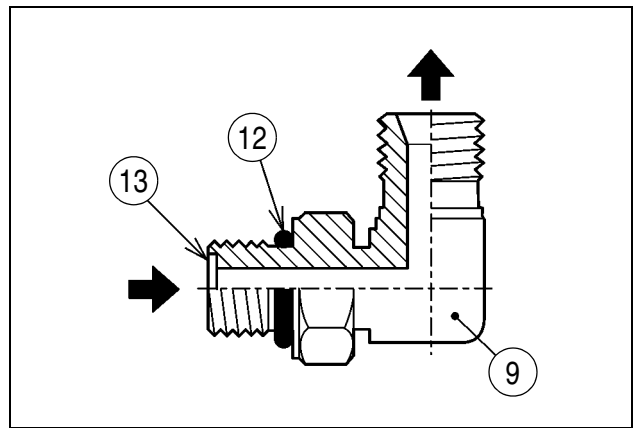

BS07N150

Figure 91

18. Dust tends to accumulate on the inside elbow (9) (curved area). Clean parts to avoid contamination (projected portion).
19. Check the O-ring (12) for damage, and replace, if damaged.
20. After cleaning, install to the original position in the reverse order of disassembly. Refer to torque charts for tightening hose (11).
21. Reinstall the floor mat and floor plate.

RUBBER CRAWLER TRACK

Rubber track offers many benefits over metal track, but must be used in accordance to the manufacturer's specifications. The machine guarantee does not cover improper operation at job sites. Do not operate the machine over objects such as steel plates, steel pipes, concrete rod, stones and rocks with sharp edges. Observe operating conditions and characteristics of rubber track to gain optimum performance.

RUBBER TRACK OPERATION

	Rubber belt	Iron shoe
Less vibration	◎	△
Smooth run	◎	○
Low noise	◎	△
Harmless for paved road	◎	△
Easy handling	◎	△
Not damageable	△	◎
Large traction force	◎	◎

◎ : Excellent ○ : Good △ : Ordinary

BS07N292

Figure 111

TRACK COMPARISON

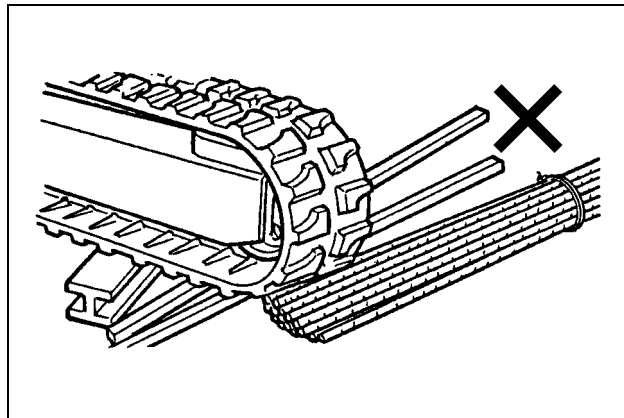

BS07N286

Figure 112

DO NOT operate in gravel mixed land, rugged and solid rock bed, over iron scraps, or edges of iron plates such as concrete rebar.

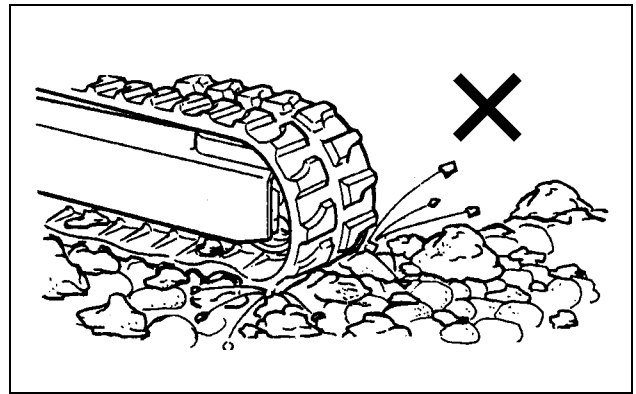

BS07N287

Figure 113

DO NOT operate or travel over river beds with stones of different sizes. Rubber crawler belts may be damaged or come off the rollers. The service life of the rubber crawler belts will be reduced if the belt is not maintained with the correct tension.

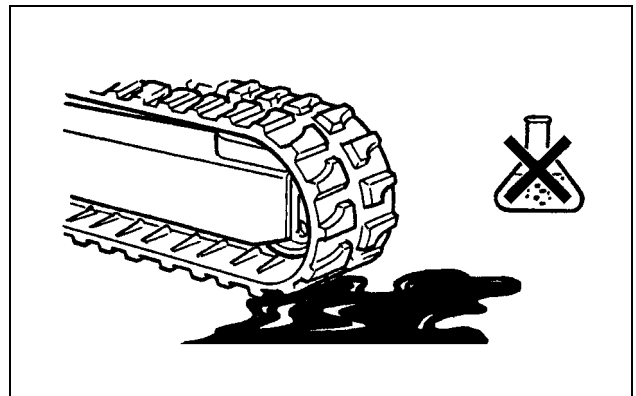

BS07N288

Figure 114

DO NOT operate on oil contaminated surfaces. Oil will damage the rubber crawler belts.

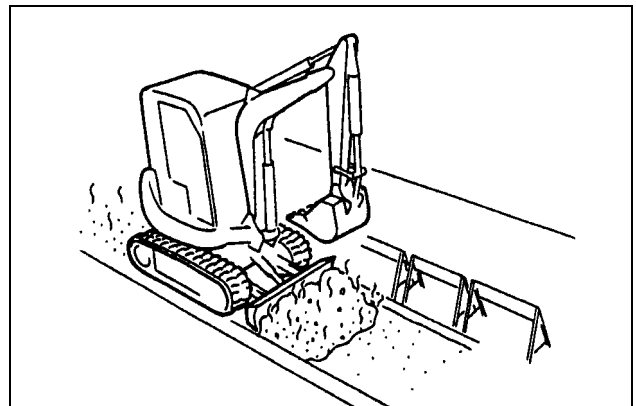

BS07N287

Figure 115

DO NOT operate near open fires, or on steel plates exposed to the sun or use in asphalt leveling. Heat will damage rubber crawler belts.

When storing the machine for long periods, indoor storage is recommended. Rubber crawler belts can be damaged if exposed for long periods of time to harsh environments in a non-operational mode.

ELECTRICAL COMPONENTS

FUSES

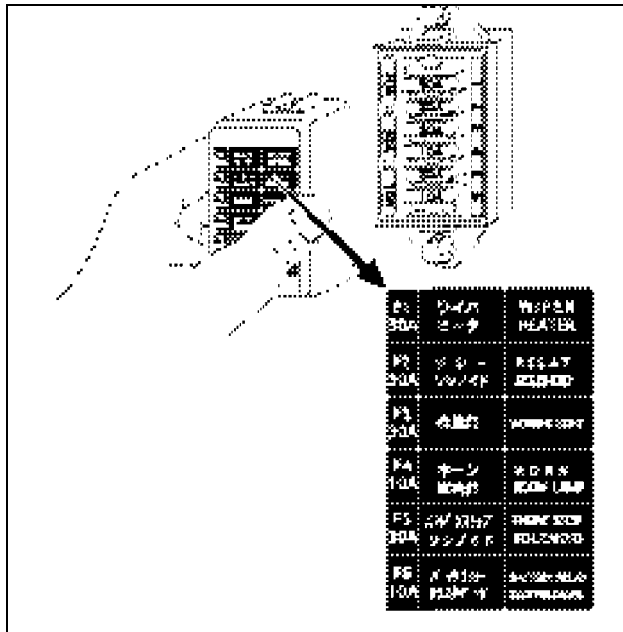

BS07N387

Figure 1

Fuses protect the electrical system from excess current. Replace a blown fuse or any fuse generating white powder on it.

Always replace fuses with a fuse of the same capacity. The spare fuses are stored in the back side of the fuse box cover.

NOTICE: Make certain the starter switch is in the OFF position before replacing fuses.

NO.	AMPS	FUNCTION
1	30A	WIPER, HEATER
2	30A	RELAY, SOLENOID
3	30A	WORK LAMP
4	10A	HORN, CAB LIGHT
5	30A	ENGINE STOP SOLENOID
6	10A	BATTERY RELAY, CLUSTER GAUGE

FUSIBLE STARTER LINK

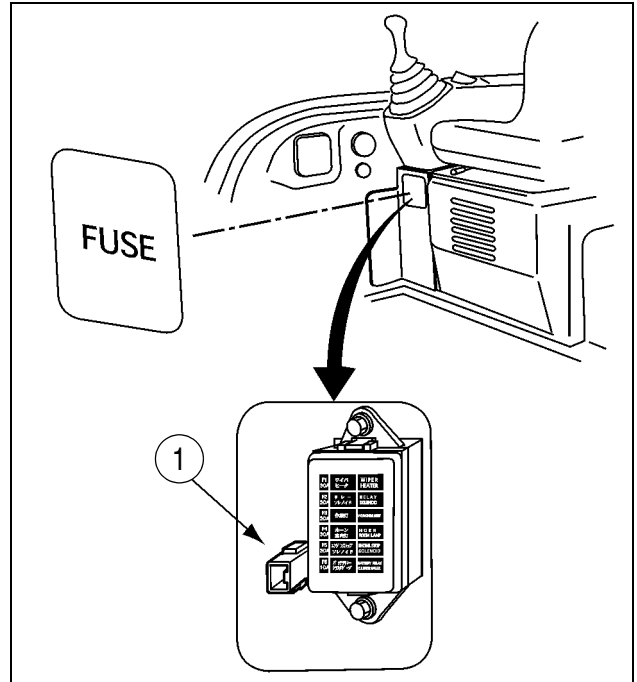

BS07N388

Figure 2

If the electrical power does not come on when the starter key switch is in the on position, the fusible link may be faulty. Inspect and replace the red fusible link (1).

The fusible link protects the electrical system from current over load. The fusible link functions like a fuse.

⚠ WARNING ⚠

Never replace a faulty fuse with a higher amperage fuse. Never use a jumper in place of a fuse. Never splice accessories directly into fuse terminals. Failure to comply could result in death or serious injury.

M1728

SPEED AND GRADEABILITY

	Rubber Crawler Belt		Steel Crawler Belt	
Swing Speed	8.7 min ¹ (8.7 RPM)			
Travel Speed	Low (1st)	High (2nd)	Low (1st)	High (2nd)
	2.5 km/h (1.6 mph)	4.5 km/h (2.8 mph)	2.5 km/h (1.6 mph)	4.5 km/h (2.8 mph)
Gradeability	58% (30°)			

ENGINE

Model	YANMAR 3TNV88-BPYB
Type	Water cooled, 4 cycle type swirl chamber type diesel engine
Number of cylinders - Bore X Stroke	3 - 88 mm X 90 mm (3 - 3.46 in. X 3.54 inch)
Total Displacement	1.642 liters (100.2 cubic inch)
Output Rating	21.2 kW (2400 min ¹) 29 PS (2400 RPM)
Maximum Torque	98.4 Nm (1440 min ¹) 72.3 lbf ft (1440 RPM)
Starting Motor	12 V (1.7 kW)
Generator	12 V (55 A)

HYDRAULIC COMPONENTS

Hydraulic Pump	Variable displacement axial piston pump
Hydraulic Motor	Axial piston
Hydraulic Motor with Reducer (Travel)	2 - Axial piston, 2-speed motor
Control Valve	10- spool multiple control valve
Cylinder (Boom, Arm, Swing, Bucket, Dozer)	Double action cylinder
Return Filter	Filter type with bypass valve (30 microns)

SIDE DIGGING AND DOZER

Type	Boom swing by hydraulic cylinder
Boom Swing Angle Right	60°
Boom Swing Angle Left	70°
Dozer Blade Travel (Up/Down)	540/440 (21.3/17.3)

CLICK HERE TO **DOWNLOAD** THE COMPLETE MANUAL

- Thank you very much for reading the preview of the manual.
- You can download the complete manual from: www.heydownloads.com by clicking the link below



- Please note: If there is no response to CLICKING the link, please download this PDF first and then click on it.

CLICK HERE TO **DOWNLOAD** THE COMPLETE MANUAL