

ORIGINAL INSTRUCTIONS

OPERATOR'S MANUAL

E30B

Tier 4B (final)

Compact Hydraulic Excavator

PIN NETN31001 and above

Part number S2HW00049ZE03

2nd edition English

November 2015

Replaces part number S2HW00049ZE01



CLICK HERE TO **DOWNLOAD** THE COMPLETE MANUAL

- Thank you very much for reading the preview of the manual.
- You can download the complete manual from: www.heydownloads.com by clicking the link below



- Please note: If there is no response to CLICKING the link, please download this PDF first and then click on it.

CLICK HERE TO **DOWNLOAD** THE COMPLETE MANUAL

Product identification

Model, serial number, and year of manufacture

Record the machine and Product Identification Numbers (PIN). When ordering parts and obtaining information or assistance, always supply your dealer with the type and PIN of your machine or accessories. Keep a record of these numbers and your Manufacturer's Statement of Origin in a safe place. If the machine is stolen, report the numbers to your local law enforcement agency.

Machine identification

Model name

Product Identification Number (PIN)

Model year

The PIN plate is located on the front, right-hand side the machine.

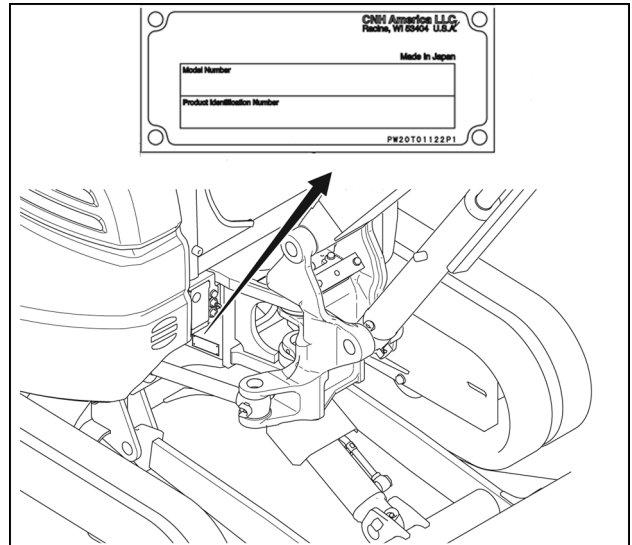

RAIL14MEX0074AA 1

Engine identification

Engine make and model

Engine serial number

The serial number plate is located on the engine valve cover.

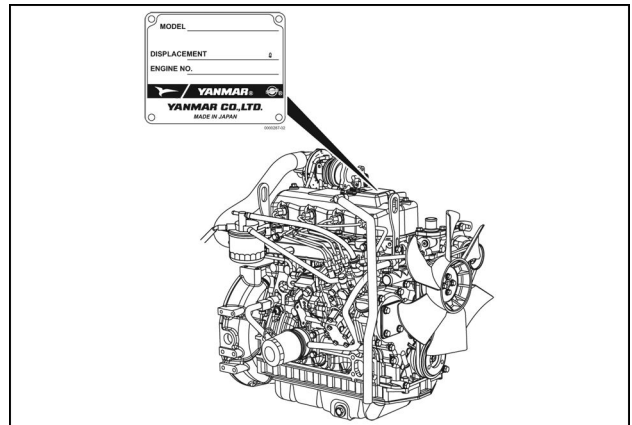

RAIL14CEX0016AA 2

Hour meter

Hour meter reading

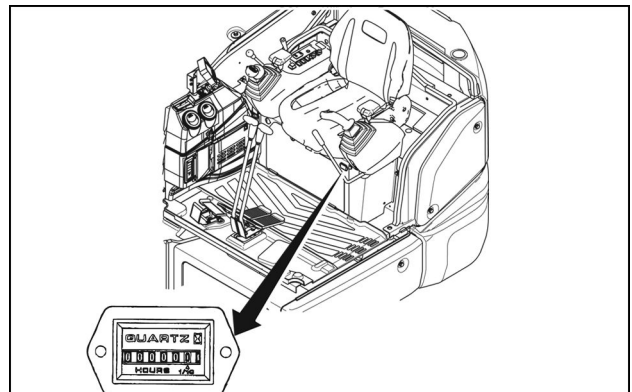

RAIL14CEX0019AA 3

2 - SAFETY INFORMATION

Safety rules

Personal safety





This is the safety alert symbol. It is used to alert you to potential personal injury hazards. Obey all safety messages that follow this symbol to avoid possible death or injury.

Throughout this manual and on machine safety signs, you will find the signal words DANGER, WARNING, and CAUTION followed by special instructions. These precautions are intended for the personal safety of you and those working with you.

Read and understand all the safety messages in this manual before you operate or service the machine.

 DANGER indicates a hazardous situation that, if not avoided, will result in death or serious injury. The color associated with DANGER is RED.

 WARNING indicates a hazardous situation that, if not avoided, could result in death or serious injury. The color associated with WARNING is ORANGE.

 CAUTION indicates a hazardous situation that, if not avoided, could result in minor or moderate injury. The color associated with CAUTION is YELLOW.

FAILURE TO FOLLOW DANGER, WARNING, AND CAUTION MESSAGES COULD RESULT IN DEATH OR SERIOUS INJURY.

Machine safety

NOTICE: Notice indicates a situation that, if not avoided, could result in machine damage or property damage. The color associated with Notice is BLUE.

Throughout this manual you will find the signal word Notice followed by special instructions to prevent machine damage or property damage. The word Notice is used to address practices not related to personal safety.

Information

NOTE: Note indicates additional information that clarifies steps, procedures, or other information in this manual.

Throughout this manual you will find the word Note followed by additional information about a step, procedure, or other information in the manual. The word Note is not intended to address personal safety or property damage.

 Air-conditioning system 

The air-conditioning system is under high pressure. Do not disconnect any lines. The release of high pressure can cause serious injury.

The air-conditioning system contains gases that are harmful to the environment when released into the atmosphere. Do not attempt to service or repair the system.

Only trained service technicians can service, repair, or recharge the air-conditioning system.

 Personal Protective Equipment (PPE) 

Wear Personal Protective Equipment (PPE) such as hard hat, eye protection, heavy gloves, hearing protection, protective clothing, etc.

Operator's seat belt

⚠ WARNING

Roll-over hazard!

Securely fasten the seat belt. Your machine is equipped with a Roll-Over Protective Structure (ROPS) cab, ROPS canopy, or ROPS frame for your protection. The seat belt can help ensure your safety if it is properly used and maintained. Never wear a seat belt loosely or with slack in the belt system. Failure to comply could result in death or serious injury.

W0143A

Seat belt

1. Insert the metal end of the belt strap **(2)** into the latch mechanism **(1)**.

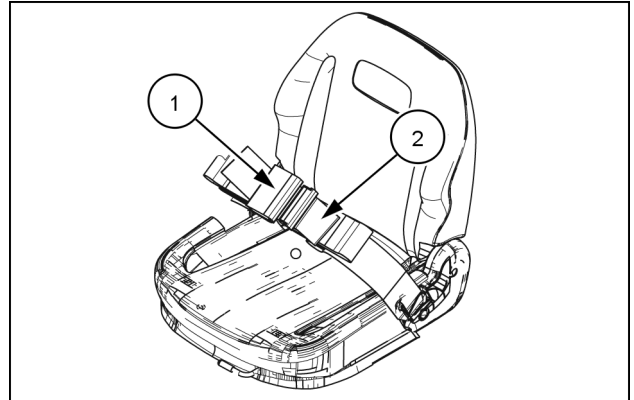

RAIL14CEX0020AA 1

1. Latch mechanism
2. Belt strap

2. Lift up the latch mechanism **(1)** to unlatch the seat belt.

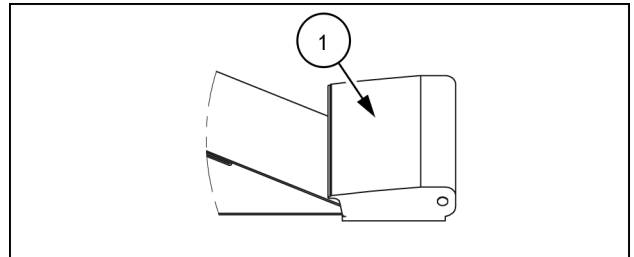

RAIL14CEX0021AA 2

WARNING — California proposition 65

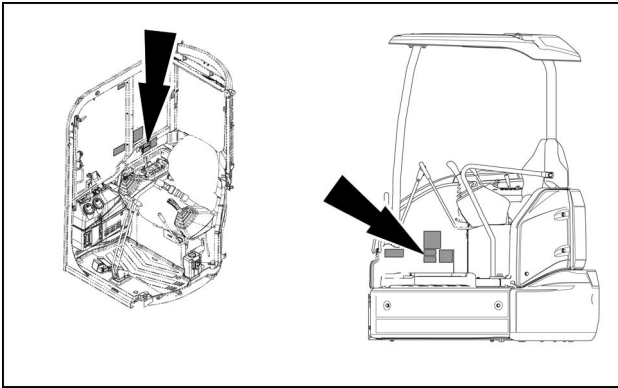

RAIL14MEX0036AA 33

WARNING

California proposition 65. Battery posts, terminals, and related accessories contain lead and lead compounds, chemicals known to the State of California to cause cancer and reproductive harm. Wash hands after handling. Failure to comply could result in death or serious injury.

On a cab machine, this safety decal is located on the right-hand side, inside the cab. On a canopy machine, this safety sign is located on the seat stand cover.

Safety sign number: YN20T01495P1

Quantity: 1

! **WARNING**

CALIFORNIA Proposition 65
 Battery posts, terminals, and related
 accessories contain lead and lead compounds,
 chemicals known to the State of California
 to cause cancer and reproductive harm.
 Wash hand after handling. YN20T01495P1

YN20T011495P1 34

WARNING — California proposition 65

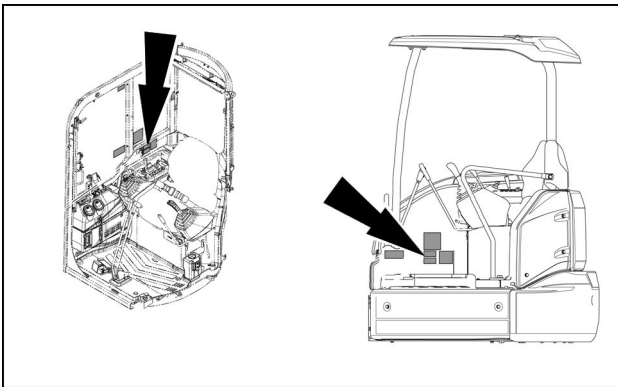

RAIL14MEX0036AA 35

WARNING

California proposition 65. Diesel engine exhaust and some of its constituents are know to the State of California to cause cancer, birth defects, and other reproductive harm. Failure to comply could result in death or serious injury.

On a cab machine, this safety decal is located on the right-hand side, inside the cab. On a canopy machine, this safety sign is located on the seat stand cover.

Safety sign number: 2432T6457

Quantity: 1

! **WARNING**

CALIFORNIA Proposition 65
 Diesel engine exhaust and some
 of its constituents are known
 to the State of California to
 cause cancer, birth defects,
 and other reproductive harm.
 2432T6457

2432T6457 36

Move away from me.
Wave hands back and forth (palms outward).



RCPH10WHL019BAD 64

Go this far.



RCPH10WHL020BAD 65

All stop and hold.

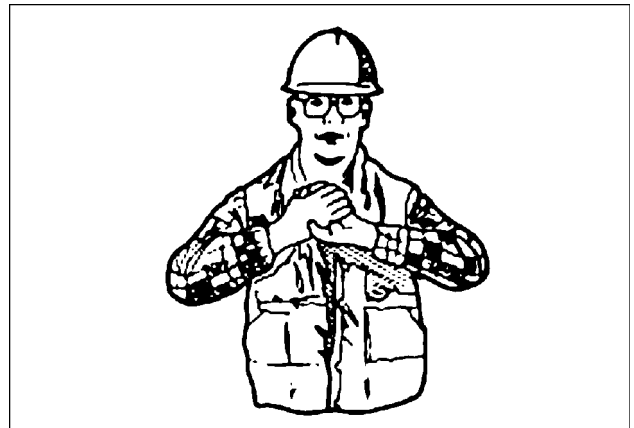

RCPH10WHL002BAD 66

Stop
Move one hand back and forth.

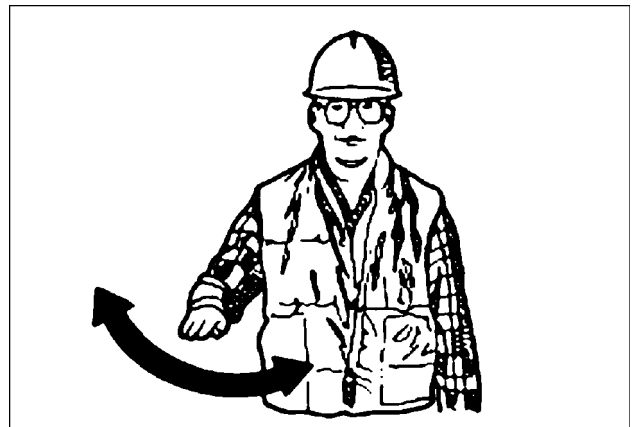

RCPH10WHL009BAD 67

Operator's seat

Operator's seat

▲ WARNING

Loss of control hazard!

Do not make seat adjustments while the machine is in motion. All seat adjustments should be made with the machine stationary and the safety lever in the LOCK position.

Failure to comply could result in death or serious injury.

W0393A

Horizontal seat adjustment

To slide the seat back and forth:

1. Pull up on the handle **(1)**.
2. Adjust the seat to a distance at which you can easily operate the control levers and pedals.
3. Release the handle **(1)** and check that the seat is securely locked.

Adjustable length: **105.0 mm (4.1 in)**

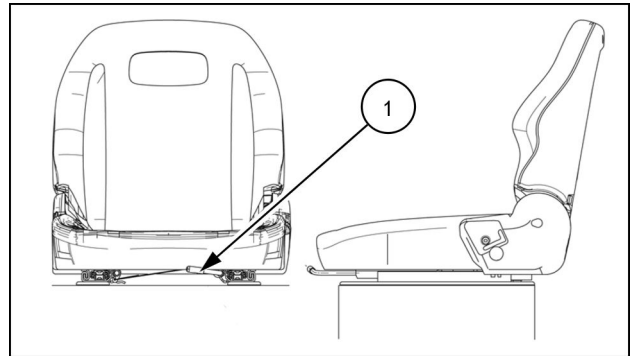

RAIL14CEX0080AA 1

Left-hand side controls

Radio (option)

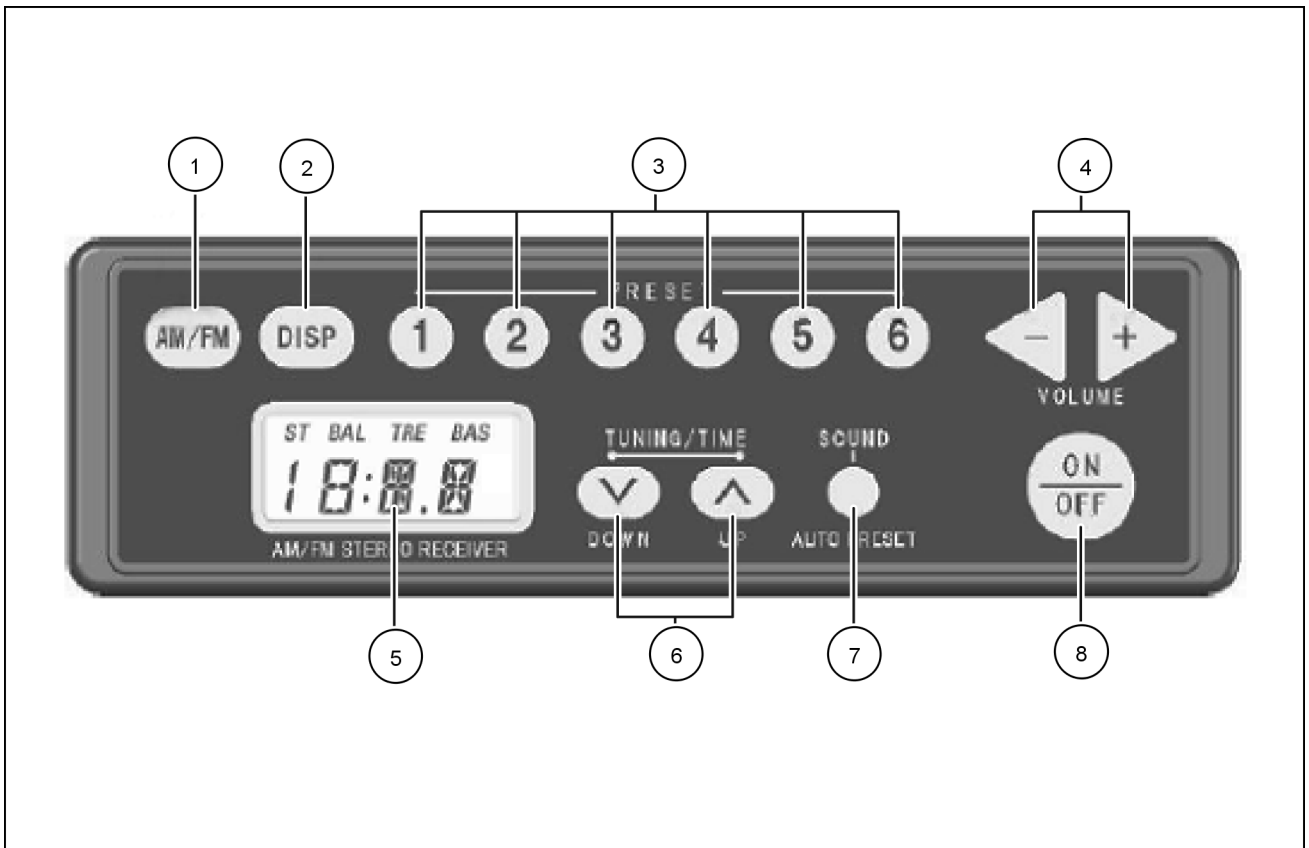

RAPH12CEX0095FA 1

- 1. Power switch
- 2. AM/FM switch
- 3. Volume control
- 4. UP/DOWN key
- 5. Preset key
- 6. DISP (display change) key
- 7. Sound control key
- 8. Display (time/frequency)

1 – Power control

Press the power switch (1) and the power is switched from off to on. The band AM or FM will display briefly followed by the frequency or the time.

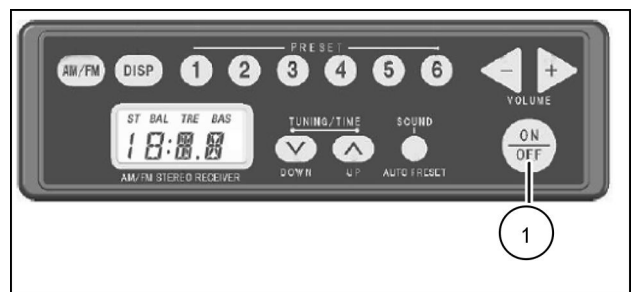

RAPH12CEX0101AA 2

Battery charge lamp (Red)

This lamp will illuminate when the ignition switch is turned to the ON position and the lamp must turn off after engine start.

If the charging system experiences a malfunction, the lamp will illuminate. Check the charging system if this indicator remains illuminated after engine start.

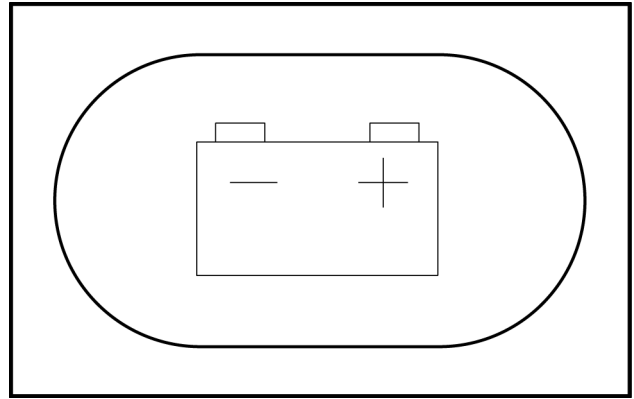

LEL11E0131AA 6

Fuel level lamp (Red)

If the fuel level is low, the warning lamp will illuminate. Stop the engine and add fuel. Do NOT allow the machine to run out of fuel.

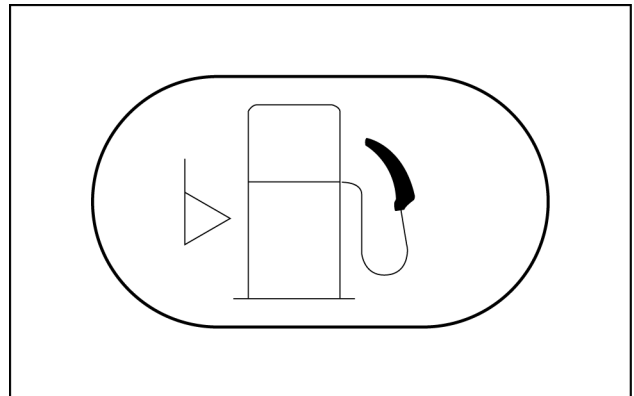

LEL11E0132AA 7

Engine air filter lamp (Red)

The engine air filter lamp illuminates if the air cleaner filter is clogged.

If the lamp illuminates, immediately stop the machine and clean or replace the air filter.

See the maintenance section in this manual for additional information.

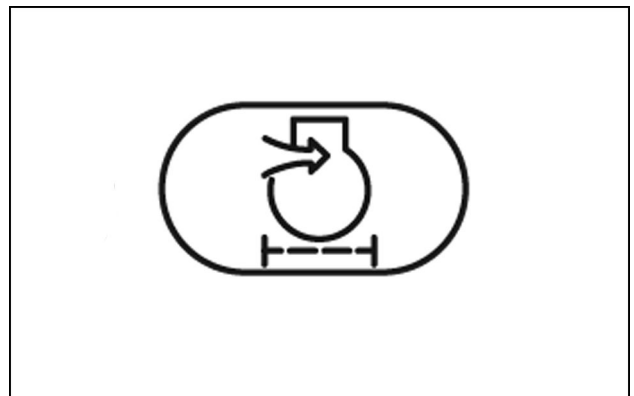

RAIL14CEX0108AA 8

Indicator lamps

High (2nd) speed travel lamp (Yellow)

The high speed travel indicator lamp will illuminate when you select high speed with the travel speed selector switch. The travel speed selector switch is located on the grip of the right travel lever. The travel speed will automatically return to low (1st) speed when the ignition switch is in the OFF position.

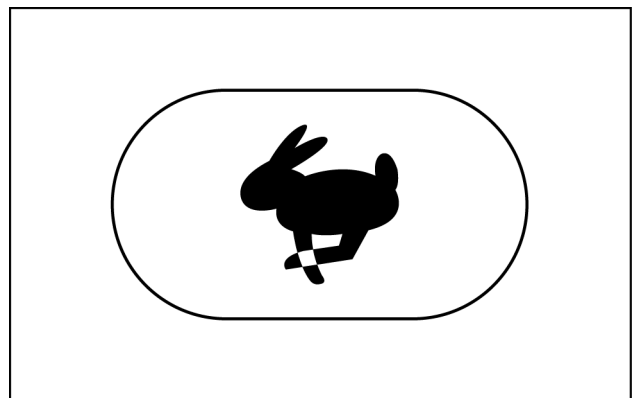

LEL11E0133AA 9

Clock setting

- Menu button (1)
- Buzzer stop button (2)
- Up arrow button (3)
- Down arrow button (4)

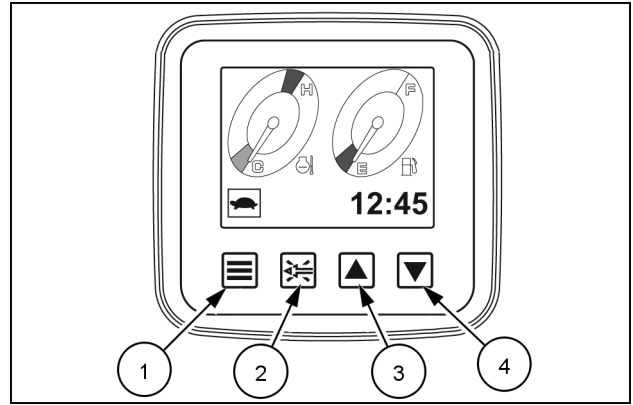

RAIL14CEX0547AA 11

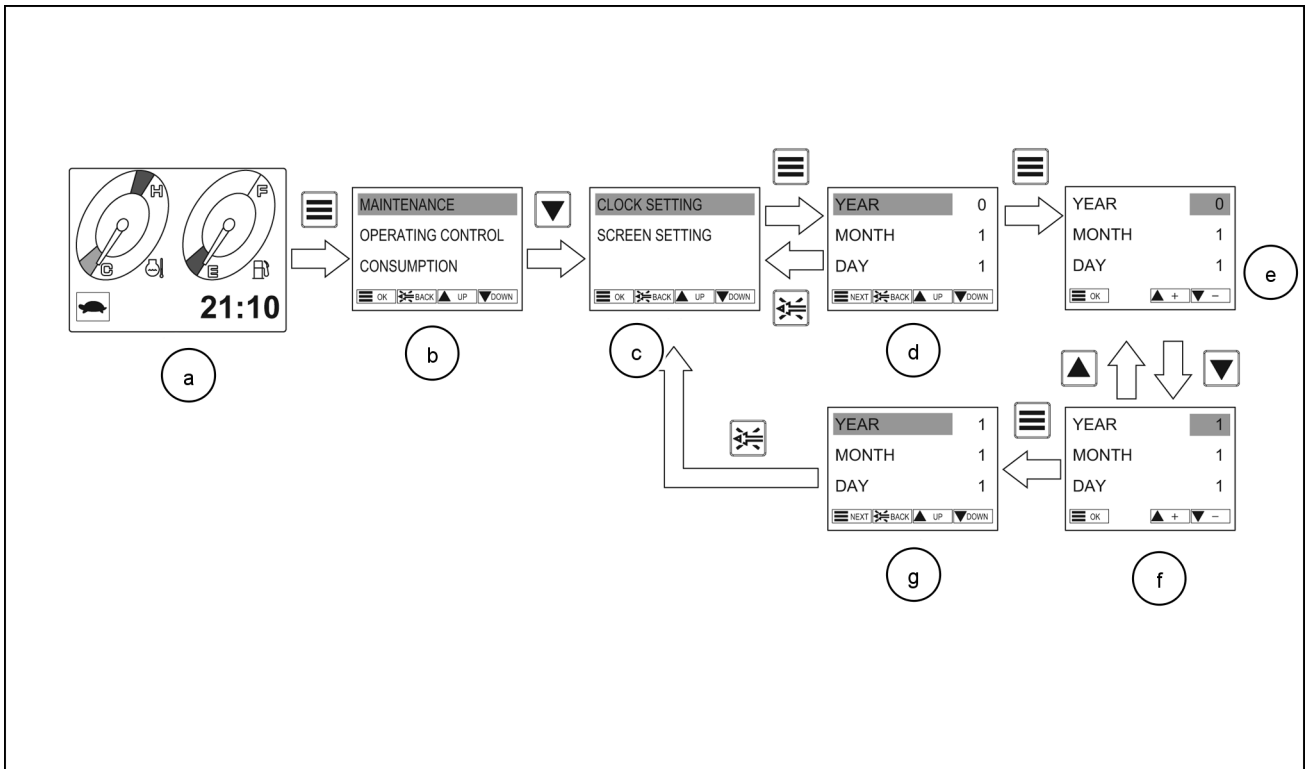

RAIL14CEX0559FA 12

1. Turn the ignition switch ON to display the main screen (a). Press the menu switch (1) to enter the user menu screen (b).
2. Use the up and down arrow switches (3,4) to move the cursor to "CLOCK SETTING". Press the menu switch (1) to enter "CLOCK SETTING".
3. Use the up and down arrow switches (3,4) to select "YEAR, MONTH, DAY, HOUR, or MINUTE"
4. Press the menu switch (1) to enter screen (e). The background color of the value highlighted turns blue.
5. Use the up and down arrow switches (3,4) to select the desired value.
6. Press the menu switch (1) to set the desired value. The background of the value turns black.
7. Press the buzzer stop switch (2) to return to the user menu screen (c).

4 - OPERATING INSTRUCTIONS

Commissioning the unit

Daily inspection

The following procedures are to be performed every **8 h** or daily, before starting the machine.

- Check the engine for any oil, fuel, or coolant leakage. Repair as required.
- Check the area around the engine and radiator for any accumulated material and remove as required.
- Check the hydraulic system components, the hydraulic oil tank, the hoses and the joints for oil leakage. Repair as required.
- Check the travel system, such as the crawlers, front idlers, and sprockets for any damage or wear. Check the cap screws for looseness.
- Check the attachments, dozer blade, cylinders, linkages and hoses for any cracks, wear or looseness. Repair as required.
- Check the guards, steps, and handrails for damage. Check the cap screws for looseness and repair and tighten them as required.
- Check the fan belt.
- Verify that the gauges and the monitor panel function properly.
- Check the work lights.
- Check the exhaust color, sound, and odor.
- Check the safety lever lock.

NOTE: See “Every 8 hours” in the maintenance section of this manual for the expanded procedures on the above checks.

Visually check the machine for deformation and damage

Even if deformation of a guard or cover does not appear to be severe, it may interfere with internal hoses and parts. Contact your authorized dealer for recommended repair.

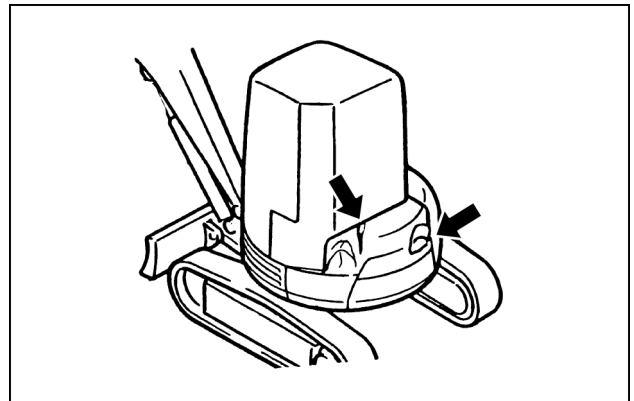

RAIL14CEX0978AA 1

Check for loose or missing bolts and nuts

Check for loose or missing bolts, and hose clamps. If you hear an irregular sound during the check, tighten the bolts and nuts. Refer to 7-5.

Parking the unit

Parking the machine

- Always park the machine on a firm, level surface.
- Avoid parking on a slope.
When parking on a slope is unavoidable, make sure the bucket teeth are stuck in the ground, lower the dozer to the ground and properly block the crawlers with wedges.

To stop the engine.

1. Turn the ignition key to the OFF position and remove it.
2. To prevent any unexpected movement, place the safety lock lever in the LOCKED position.

NOTICE: Do not shut off the engine when running at full speed, but let it run idle for some minutes to cool it down.

3. Move both travel control levers (1) to the neutral position.
4. Set the throttle control lever (2) to low idle.
5. Lower the bucket to the ground.
6. Place the dozer blade on the ground.
7. Block both crawlers with chocks.
8. Stop the engine by turning the ignition key to the OFF position.

NOTICE: Do not shut off the engine when running at full speed, let it run idle for some minutes to cool it down.

9. Set the safety lock lever (3) to the LOCK position (A).
10. Close all of the windows.

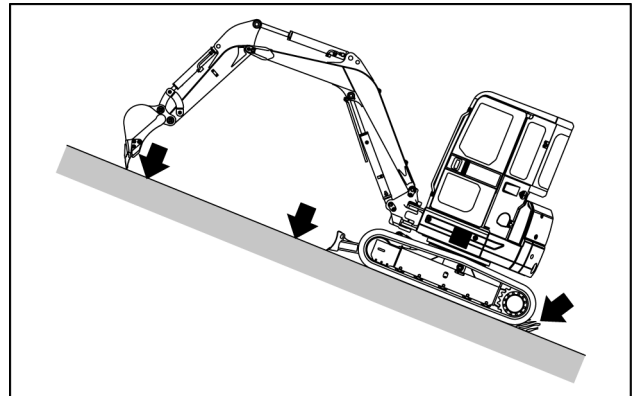

LELI11E0235AB 1

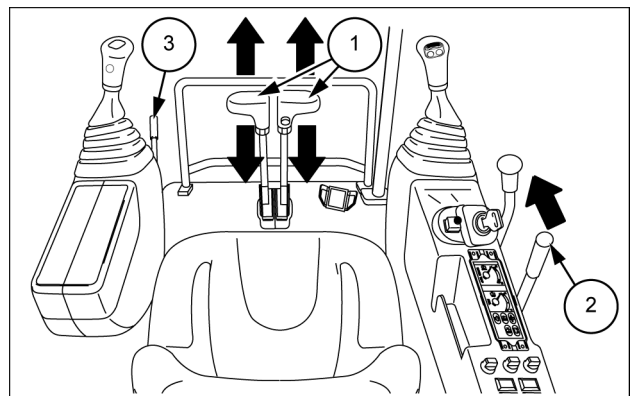

SMIL13MEX0026AB 2

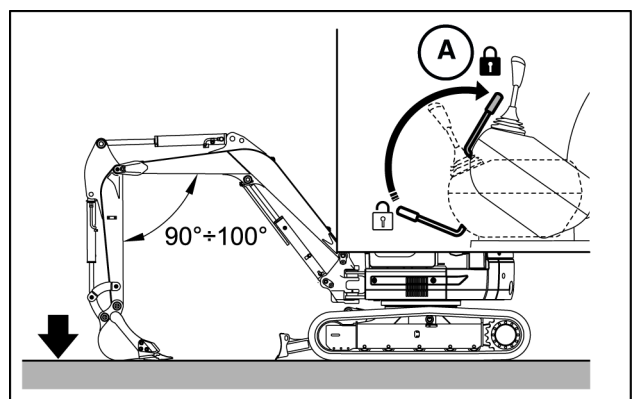

LELI11E0237AB 3

CLICK HERE TO **DOWNLOAD** THE COMPLETE MANUAL

- Thank you very much for reading the preview of the manual.
- You can download the complete manual from: www.heydownloads.com by clicking the link below



- Please note: If there is no response to CLICKING the link, please download this PDF first and then click on it.

CLICK HERE TO **DOWNLOAD** THE COMPLETE MANUAL

6 - WORKING OPERATIONS

General information

Operating the controls

▲ DANGER

Avoid injury!

Keep clear of the machine. Make sure that the area is clear of obstacles and persons before you operate the machine. Always look around before you start the swing operation. Sound the horn before you begin the swing operation.

Failure to comply will result in death or serious injury.

D0124A

The following instructions inform the operator of the basic function of each hydraulic control. Learning these instructions and practicing with the hydraulic controls will increase operator efficiency during machine operation. Prior to machine operation, each operator must read carefully, learn and implement the safety rules described in this manual and located on the machine.

NOTICE: *If any fault occurs during machine operation, immediately stop the engine. Make sure to repair any faulty condition before resuming operation. Normal positioning of the machine, for the purpose of determining front, rear, forward and reverse, is with the travel motors located behind the operator's cab.*

Getting out of soft ground

⚠ WARNING

Avoid injury!
 Keep all persons and objects clear while any part of this machine is in motion.
 Failure to comply could result in death or serious injury.

W1282A

⚠ WARNING

Avoid injury!
 Operate controls only when seated in the operator's seat.
 Failure to comply could result in death or serious injury.

W0956A

If possible, avoid travelling on soft ground. Avoid getting caught in the mud. In the event that the machine gets caught in the mud, get out of it as follows.

One crawler caught in mud

When a crawler gets caught in mud, lay logs or boards on the mud to form a base. Raise the dozer blade and Operate boom and arm to form a crossing angle between **90 - 110 °**. Push outer side of bucket against the ground to lift the machine body.

NOTICE: When you lift up the machine use the bottom of the bucket, not the teeth, to push on the ground.

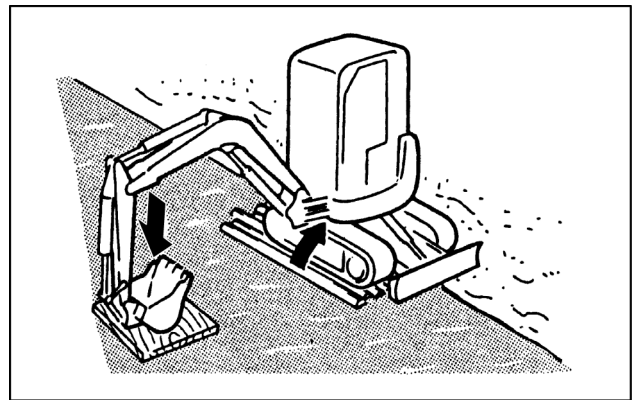

LEL111E0224AB 1

Both crawlers caught in mud

When both crawlers get caught in mud and the machine does not move because it skids, provide logs and boards, as described in the previous step and anchor the bucket firmly to the ground so that you can help the machine to come out from mud.

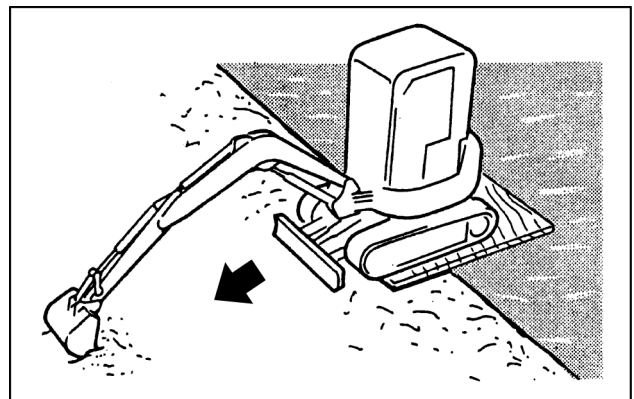

LEL111E0225AB 2

If the machine is unable to travel because the crawlers are stuck in mud, sand or gravel, raise each crawler side alternately by pushing the bucket against the ground and scraping off mud, sand, or gravel. Gravel and mud may be cleared off by rotating the raised crawler back and forth.

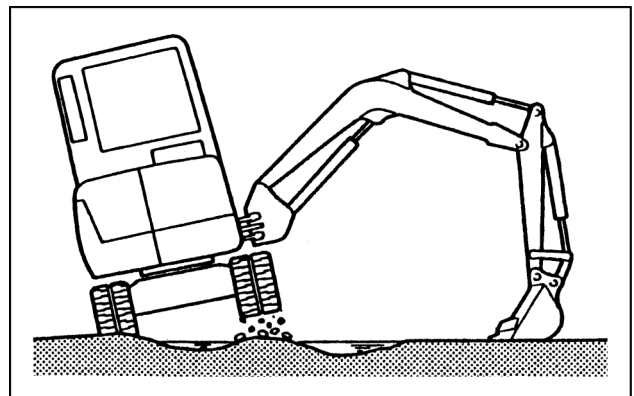

LEL111E0226AA 3

Use care so that the bucket does not damage the rubber crawler while working.

Do not move the machine pressing the bucket against a concrete surface or walls.

Lower the machine slowly, if it had previously been lifted by means of the attachment.

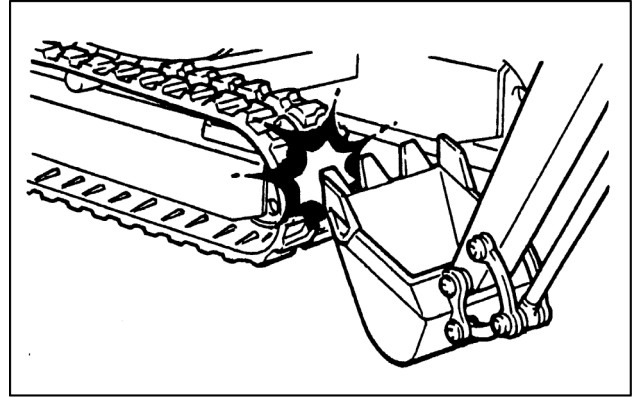

LELI11E0265AA 7

If the machine is operated in salty corrosive places, the core metal can detach easily. Do not use the rubber crawler under such circumstances. If the rubber crawlers come in contact with these substances wash them with water.

The rubber crawlers have to be used with a temperature range between **-25 °C (-13 °F)** and **+55 °C (131 °F)**.

NOTE: Use the rubber crawlers under proper tension, to prevent them from coming off the rollers. Operate the rubber crawler carefully even when tensioning is proper.

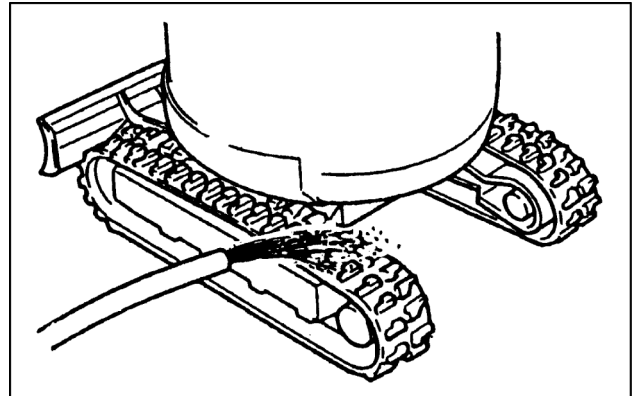

LELI11E0266AA 8

Avoid changing direction of the machine on places with different level (about **20 cm (7.87 in)**). To overcome the gap, place the machine perpendicular to the obstacle.

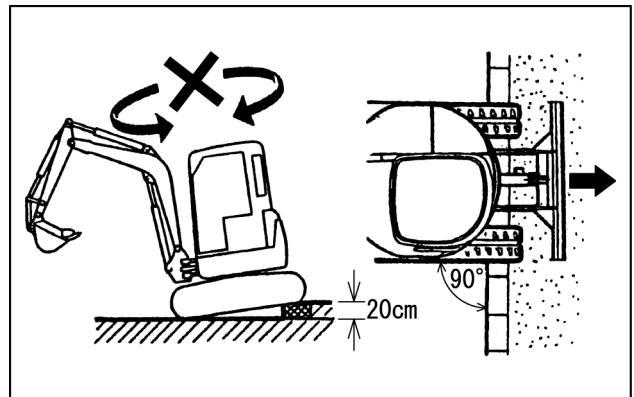

LELI11E0267AB 9

When climbing on a slope in reverse, avoid changing the machine direction while climbing between the level ground and the slope.

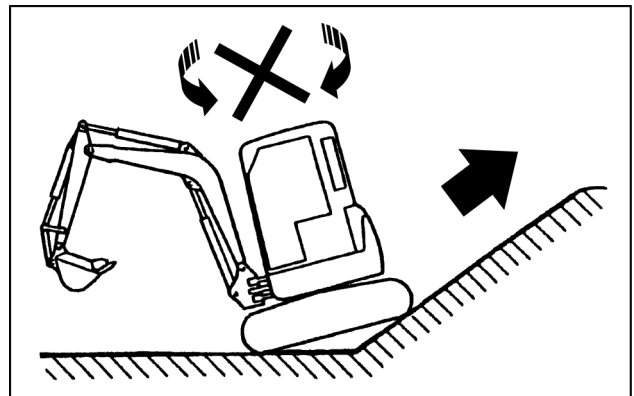

LELI11E0268AB 10

Installation

Metal fitting

The pressure exerted by the fitting (3) on the hose (1) ensures tightness (2). Use caution to assemble and disassemble both pieces in order not to damage the seat.

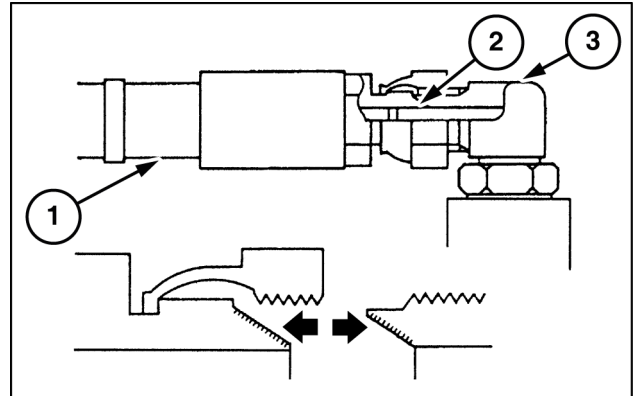

LEL111E0297AB 1

Fitting with O-ring

The O-ring (2), allows to insulate the oil pressure inside of hose (1) and to avoid oil spillages.

The tightening torque of the joint of each hydraulic hose (1) is determined by the diameter of the hose fitting thread. If you notice a fault of operation, repair hose connection or replace it.

When connecting worn parts, pay particular attention to keep sealing surfaces clean from dirt and try not to damage them.

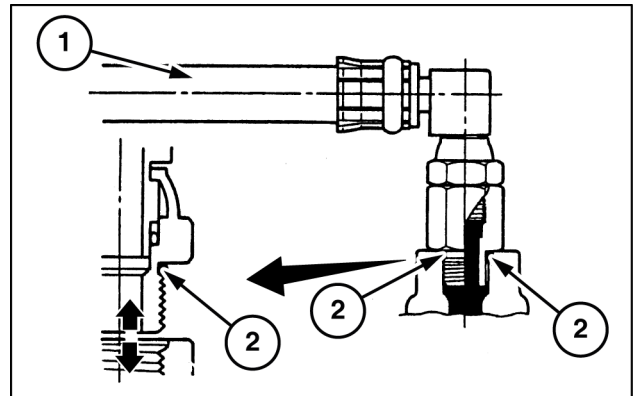

LEL111E0298AB 2

O-ring

If the fitting is loose and oil leaks may occur, do not tighten it. It is necessary to install a new O-ring and to check again for tightness.

Never install a damaged and deteriorated O-ring even if it is new one. The use of an O-ring other than the specified one, causes oil leakage and short life of hydraulic equipment.

Joint

Be careful not to damage hoses, pipes or seal faces, this can impair the tightness.

Keep seal surfaces free from dirt.

Fitting with foreign matter inside causes oil leakage.

Hose

Avoid high pressure hoses to twist during connection. Life of twisted hoses is drastically reduced.

Wash pipes and hoses, both inside and outside, with washing fluid and accurately dry them before reconnection.

Every 8 hours

Engine coolant level

⚠ WARNING

Burn hazard!

Always remove the recovery tank cap **BEFORE** you remove the filler cap. Never remove either cap while the engine is running or the coolant is hot. Stop the engine and let the system cool. Using a thick cloth, loosen the cap slowly and allow the pressure to escape. Failure to comply could result in death or serious injury.

W0361A

Check the coolant level

NOTICE: The engine coolant level is higher than normal when engine is warm. The coolant level will lower as the engine temperature lowers. Maintain the coolant level at the FULL mark when the engine is cold.

The radiator reservoir tank (3) is located on the right side of the engine compartment. Check the coolant level with a cold engine only.

1. Check the radiator reservoir tank (3) for the proper coolant level. The proper coolant level is between the FULL and LOW marks visible on the radiator reservoir tank (3).
2. Open the cap (2) of the radiator reservoir tank (3).
3. If the coolant level is below the LOW mark, fill the radiator reservoir tank (3) to the FULL mark with the proper coolant.
4. Close and tighten the cap (2) of the radiator reservoir tank (3).

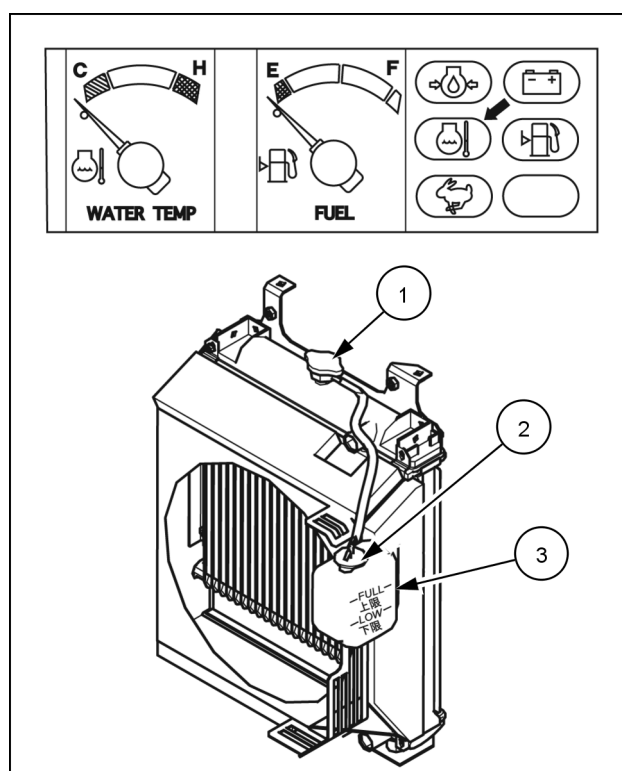

RAIL14CEX0687BA 1

1. If the radiator reservoir tank is empty, check the engine cooling system for any leaks and items in need of repair.
2. Remove the radiator cap (1) and check for the proper coolant level.
3. If the coolant level in the radiator is low, fill the radiator with the proper coolant mixture.
4. Fill the radiator reservoir tank (3) with the proper coolant mixture.
5. Close and securely tighten the radiator cap (1).
6. Before you operate the machine, contact your authorized dealer for repairs.

Work lights

1. Turn the ignition key to the ON position.
2. Turn on the work light switch.
3. If the work lights do not illuminate, replace the bulb.
4. If the work lights still do not illuminate, the electrical wire may be broken. Contact your authorized dealer for repair.

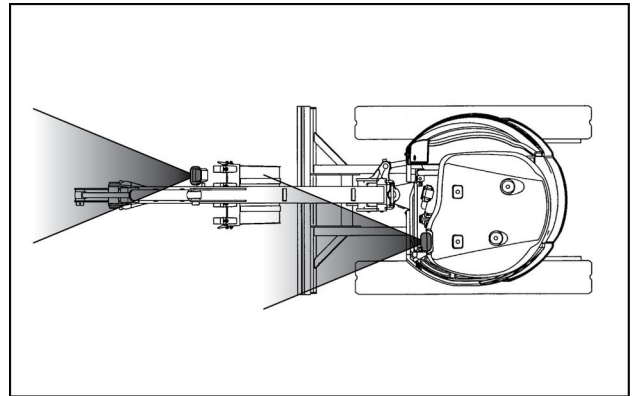

LEL11E0186AA 1

3. At the center of the crawler frame, measure gap **(A)** between the lower surface of the crawler frame and the upper surface of the track shoe.

1. Crawler Frame
2. Lower Roller
3. Iron Track Shoe
4. Rubber Track Shoe

Proper tension

A. Rubber: **70.0 - 80.0 mm (2.8 - 3.1 in)**

B. Iron: **120.0 - 135.0 mm (4.7 - 5.3 in)**

4. If the tension is not proper, adjust as explained below.

NOTICE: When you work with loose track shoes, they may come off the machine. Early wear could result from working with loose track shoes.

Adjustment

It is necessary to adjust the track shoe tension depending on the work condition at the working site. At the working site covered with many gravels and cobbles, loosen the track shoe tension as much as possible within the proper range. On the firm ground, increase the tension slightly within the proper range.

Observe the following safety precautions when working on the tracks:

- Grease nipple **(1)** can pop out due to the inner high pressure grease. Do not loosen it more than 1 turn.
- The high pressure grease is charged in the grease cylinder of the track spring. When adjusting the shoe tension or disassembling the shoe for maintenance, loosen grease nipple **(1)** within one turn to discharge the grease gradually.
- Keep the face and body away from grease nipple **(1)** when loosening it.

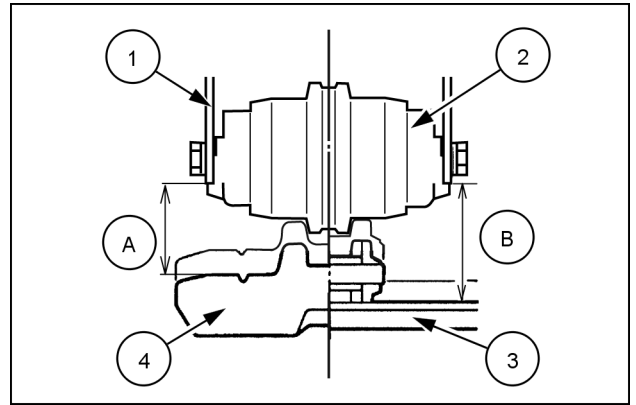

RAIL14CEX0914AA 4

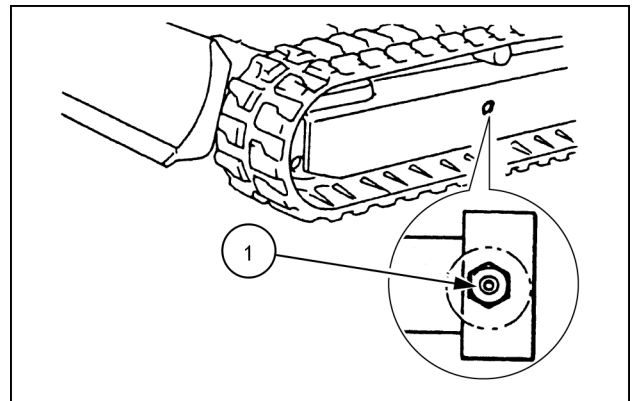

RAIL14CEX0915AA 5

If necessary, replace radiator hoses

Observe the following safety precautions:

- Inside the radiator, the high pressure steam occurs and it may cause personal injury.
- Do not loosen or remove the radiator cap when the coolant is under high pressure and temperature.
- Stop the engine before removing the radiator cap.
- Allow enough time for the coolant to cool down before removing the radiator cap.

1. Loosen the radiator cap **(1)** slowly. After making sure that the pressure is completely released, push the cap down, loosen and remove it.
2. Remove the drain plug cover. Remove the drain plug **(2)** to drain the coolant into a container.
3. Loosen the clamp, remove the damaged hose, and replace it with a new one.
4. Reinstall the drain plug and cover.
5. Fill the radiator **(4)** with the coolant and fill expansion tank **(3)** with the coolant. See 7-17.
6. After filling up, tighten the radiator cap securely.
7. Install the cover.

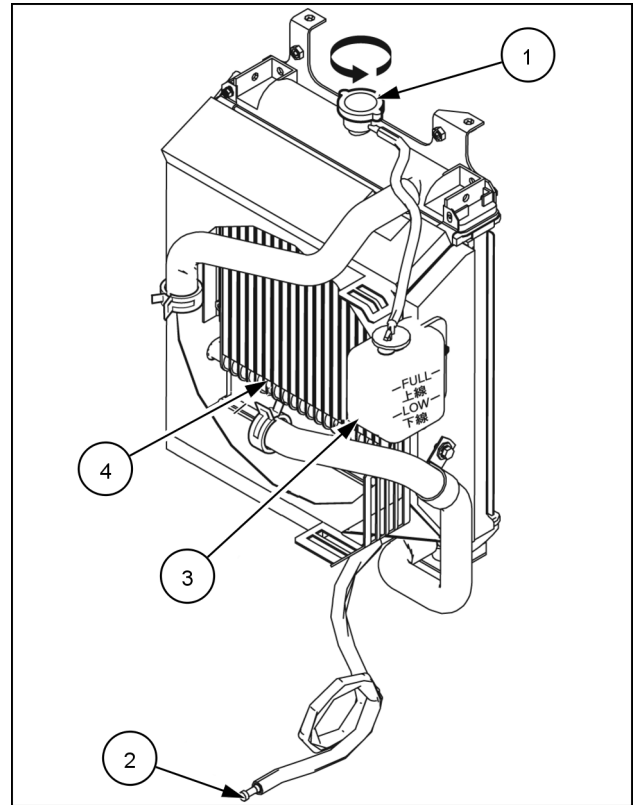

RAIL14CEX0922BA 2

Every 500 hours of operation or every 6 months

Fuel filter

⚠ CAUTION

Burn hazard!

**Wait for all components to cool before performing any operation.
Failure to comply could result in minor or moderate injury.**

C0053A

NOTICE: The oil filter cannot be reused because it is a cartridge type. Also, it cannot be disassembled for internal cleaning. Replace it by the set.

1. Stop the engine, and open the engine hood.
2. By using the fuel filter wrench, turn filter cartridge **(1)** to the left **(A)** to remove it.
3. Wipe the sealing surface of the filter base with a clean cloth to prevent dust and foreign materials from being seized.
4. Apply a thin film of clean engine oil to packing **(A)** of new filter cartridge, tighten it by hand, and then tighten an additional two-thirds of a turn.
5. Bleed the fuel system (See Page **7-52**).
6. Start the engine, run it at idling for several minutes, and then check the filter mounting area for fuel leakage.

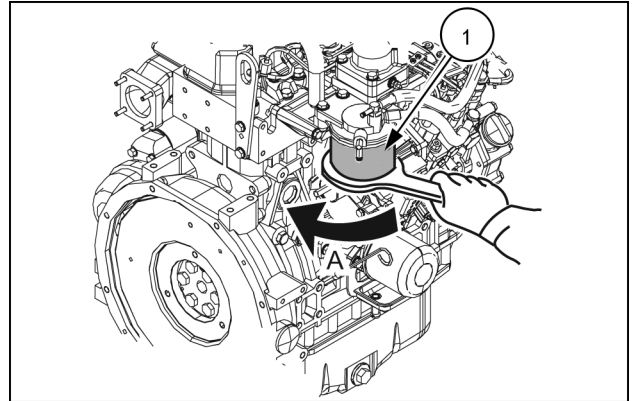

RAIL14CEX0937AA 1

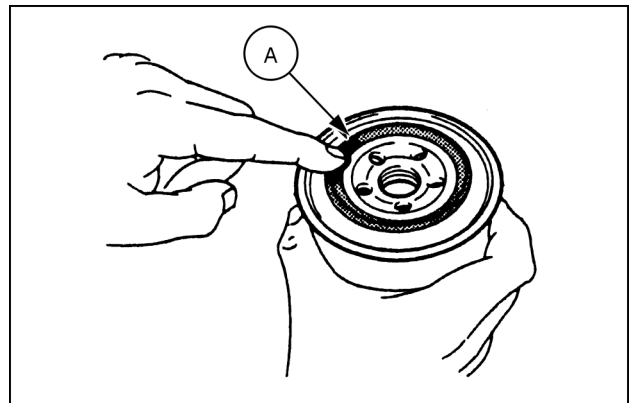

RAIL14CEX0927AA 2

Hydraulic oil (Breaker attachment option)

⚠ WARNING

Burn hazard!

Do not handle any service fluid (engine coolant, engine oil, hydraulic oil, etc.) at temperatures that exceed 49 °C (120 °F). Allow fluids to cool before proceeding.

Failure to comply could result in death or serious injury.

W0330B

NOTICE: When the hydraulic breaker is attached, the deterioration of the hydraulic oil is faster than that of the normal bucket digging work.

NOTICE: Do not drop bolts or others into the tank during the work.

Observe the safety precautions that follow:

- The oil in the hydraulic oil tank is under high temperature and pressure.
 - Stop the engine first, retract the arm cylinder and bucket cylinder, place the bucket and dozer (when installed) on the ground and stop the engine.
 - Immediately after operation, the oil is hot and it may cause burns. Wait until the oil temperature cools down before attempting to change the hydraulic oil.
1. Park the machine on the level and firm ground, swing the upper structure so that drain plug (1) on the bottom of hydraulic oil tank is positioned to the midpoint of right and left track shoe.
 2. Retract the arm cylinder and bucket cylinder, place the bucket and dozer (when installed) on the ground and stop the engine.
 3. Move the safety lock lever to the "LOCKED" position.
 4. Remove the cover under the hydraulic oil tank.
 5. Clean the surface around the hydraulic oil tank to keep it away from foreign materials.
 6. Press the breather cap (2) on the top of the hydraulic tank several times (5 - 7 times) to release the inner pressure of the hydraulic tank.
 7. Remove the bolt (3) of the tank upper cover and remove cover (4).

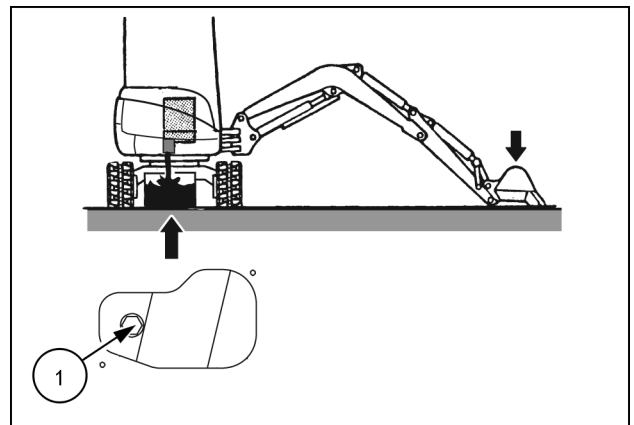

RAIL14CEX0953AA 1

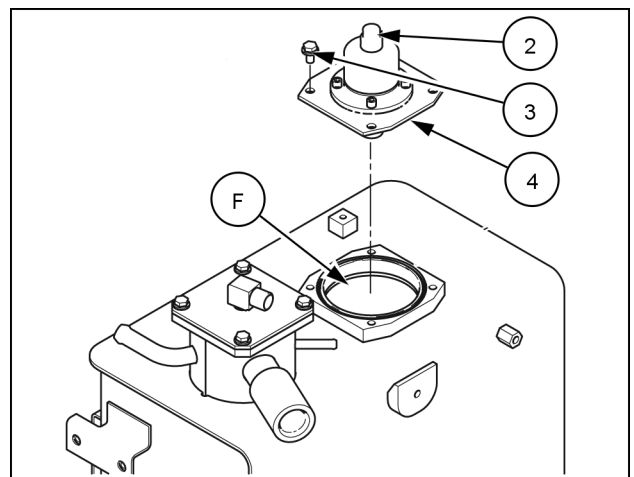

RAIL14CEX0943AA 2

Pilot line filter

⚠ WARNING

Escaping fluid!

Hydraulic fluid or diesel fuel leaking under pressure can penetrate the skin and cause infection or other injury. To prevent personal injury: Relieve all pressure before disconnecting fluid lines or performing work on the hydraulic system. Before applying pressure, make sure all connections are tight and all components are in good condition. Never use your hand to check for suspected leaks under pressure. Use a piece of cardboard or wood for this purpose. If injured by leaking fluid, see your doctor immediately.

Failure to comply could result in death or serious injury.

W0178A

Internal pressure always exists in the hydraulic circuit. Do not inspect or maintain the machine before releasing the internal pressure.

To release the internal pressure of the hydraulic oil tank, press the valve on top of the breather cap to release the pressure in the hydraulic oil tank.

Wipe off spilled hydraulic oil to prevent a fire.

On each port P of the pilot valves for left and right hand operator control levers, the pilot valve for travel, and the solenoid valve, the filtered connector is attached. If dust is adhered to these filters, the flow of hydraulic oil will be interrupted. If dust enters into the valves, it may cause failure. Remove them periodically to clean them. When cleaning the pilot line filters, place the machine in the parking position, set the safety lock lever to the "LOCKED" position, and stop the engine. Then bleed the air of the hydraulic circuit. See **7-9**.

Windshield washer reservoir (cab only)

The window washer reservoir (1) is located inside the cab near the lower left side of the operator's seat. When the fluid level becomes low, remove the cap (2) and fill the reservoir with washer fluid.

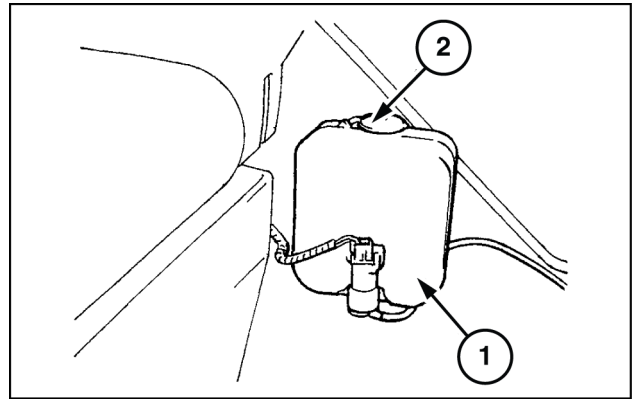

LEL11E0163AB 1

NOTICE: Do not operate the windshield washer when the reservoir is empty. This could cause damage the windshield washer reservoir motor.

Stop the sprocket **(3)** and check whether the rubber crawler **(4)** is correctly positioned on the crawler idler, on the lower rollers **(5)** and on the sprocket.

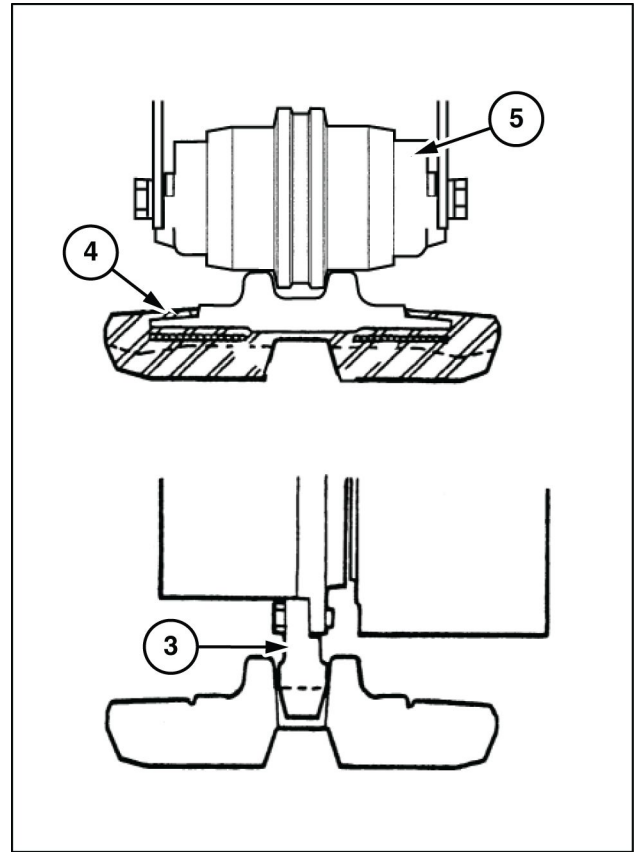

LEL11E0309BB 7

CLICK HERE TO **DOWNLOAD** THE COMPLETE MANUAL

- Thank you very much for reading the preview of the manual.
- You can download the complete manual from: www.heydownloads.com by clicking the link below



- Please note: If there is no response to CLICKING the link, please download this PDF first and then click on it.

CLICK HERE TO **DOWNLOAD** THE COMPLETE MANUAL