

ORIGINAL INSTRUCTIONS

OPERATOR'S MANUAL

E17C

Mini Excavator

Part number 90436678

1st edition English

January 2021



CLICK HERE TO **DOWNLOAD** THE COMPLETE MANUAL

- Thank you very much for reading the preview of the manual.
- You can download the complete manual from: www.heydownloads.com by clicking the link below



- Please note: If there is no response to CLICKING the link, please download this PDF first and then click on it.

CLICK HERE TO **DOWNLOAD** THE COMPLETE MANUAL

Product identification

Your machine is a hydraulic excavator. It consists of an undercarriage fitted with tracks and a swing bearing which supports the upper-structure frame. The upper-structure frame supports the attachment at the front end of the machine, plus the engine, hydraulics and the canopy. When the operator works the controls, the engine-driven pump delivers hydraulic fluid to the control valves. The control valves distribute the hydraulic fluid to the various cylinders and hydraulic motors employed. A cooling system maintains the hydraulic fluid at normal operating temperature.

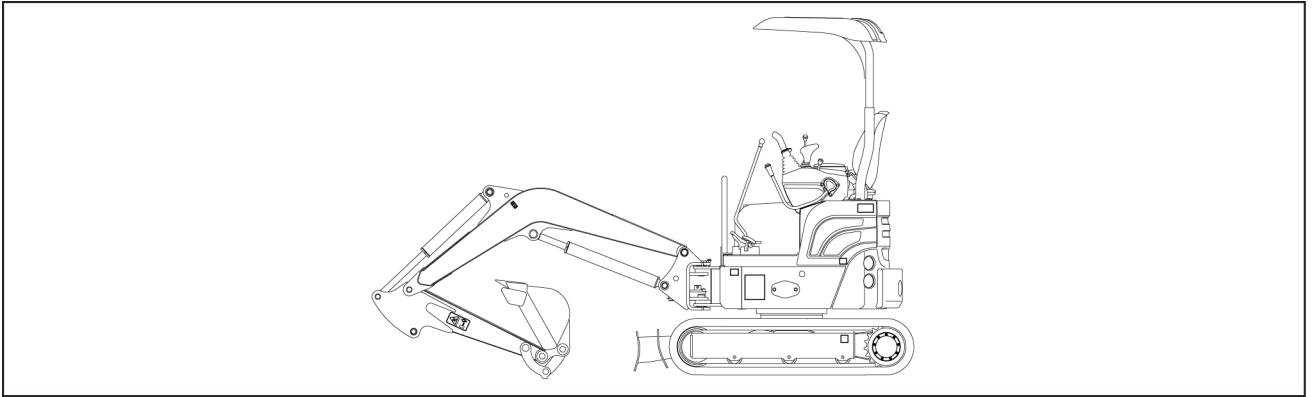

SML16MEX2247EA 1

When ordering parts, obtaining information, or seeking assistance, always supply your NEW HOLLAND CONSTRUCTION Dealer with the type and Product Identification Number (PIN) of your machine or accessories.

Write the following in the spaces below:

- Machine Type
- Machine PIN
- Machine year of manufacture
- Serial numbers of hydraulic and mechanical components

2 - SAFETY INFORMATION

Signal word definitions

Personal safety





This is the safety alert symbol. It is used to alert you to potential personal injury hazards. Obey all safety messages that follow this symbol to avoid possible death or injury.

Throughout this manual you will find the signal words DANGER, WARNING, and CAUTION followed by special instructions. These precautions are intended for the personal safety of you and those working with you.

Read and understand all the safety messages in this manual before you operate or service the machine.

 DANGER indicates a hazardous situation that, if not avoided, will result in death or serious injury.

 WARNING indicates a hazardous situation that, if not avoided, could result in death or serious injury.

 CAUTION indicates a hazardous situation that, if not avoided, could result in minor or moderate injury.

FAILURE TO FOLLOW DANGER, WARNING, AND CAUTION MESSAGES COULD RESULT IN DEATH OR SERIOUS INJURY.

Machine safety

NOTICE: Notice indicates a situation that, if not avoided, could result in machine or property damage.

Throughout this manual you will find the signal word Notice followed by special instructions to prevent machine or property damage. The word Notice is used to address practices not related to personal safety.

Information

NOTE: Note indicates additional information that clarifies steps, procedures, or other information in this manual.

Throughout this manual you will find the word Note followed by additional information about a step, procedure, or other information in the manual. The word Note is not intended to address personal safety or property damage.

⚠ Safety area ⚠

The safety area is the space necessary for the machine to operate at the maximum range of the tool and at full swing **360° plus 2 m (6.56 ft)**.

(1) Working area.

(2) Safety area.

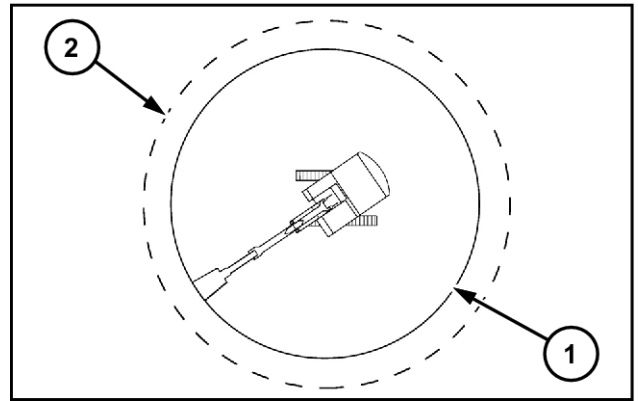

SMIL13CEX2517AB 1

(3C) Engine access door support caution - Hot surfaces

⚠ WARNING

Burn hazard!

Exhaust surfaces are hot! Always wear protective gloves when cleaning or working on the muffler, catalytic converter, or exhaust stack.

Failure to comply could result in death or serious injury.

W0329A

Location: this sign is located on the engine access door support.

Quantity: 1

Part number: 91MK-07112

This sign warns to never touch the engine or the muffler when they are still hot.

(3D) Engine compartment - battery disconnect switch

Location: this sign is located on the engine access door support.

Quantity: 1

Part number: 97MJ-05120

This sign warns to read the operator's manual before disconnect the battery.



SMIL19MEX0703AA 6

(4) Lifting location

Location: these signs are located on the boom.

Quantity: 2

Part number: 91M8-05110

This sign shows the location where a sling is attached to handle the excavator.

Never use any location other than the lifting location that this sign shows.

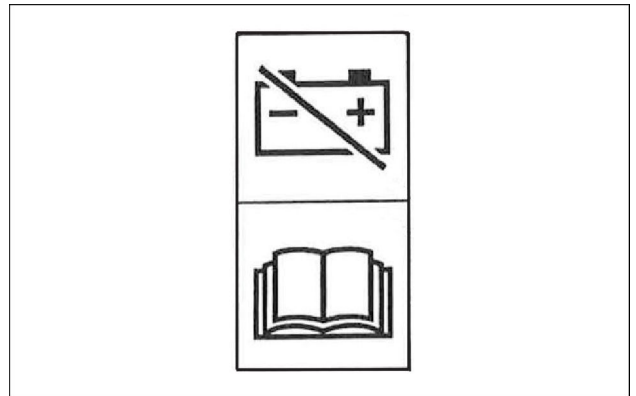

SMIL16MEX0942AA 7

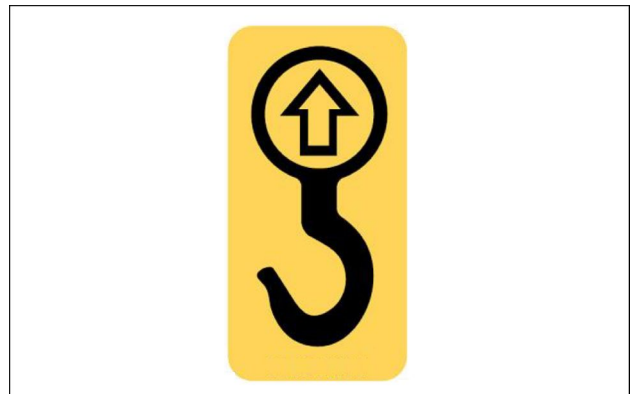

SMIL18MEX0602AA 8

(23) Frame general warning

Location: this sign is located on the right-hand side of the upper structure.

Quantity: 1

Part number: 97MJ-04100

This sign warns you to refill the recommended hydraulic oil up to the specified level.

When lift the excavator, ensure that the wire rope is proper size and keep correct hoisting method.

This sign indicates that you always need to read the operator's manual before using the machine.

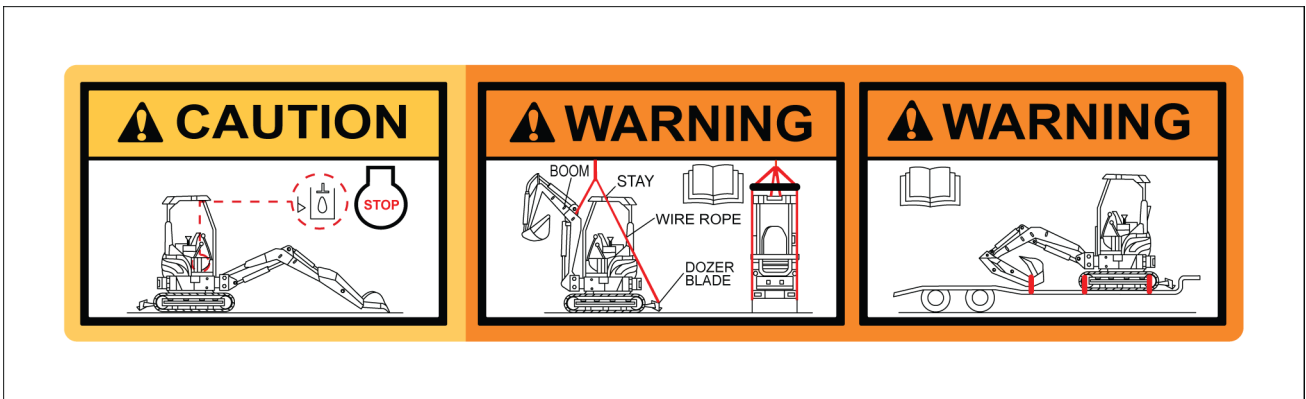

SMIL19MEX0732EA 28

(24) Compliant to Canadian Regulation ICES-002

Location: this sign is located under the operator's seat.

Quantity: 1

Part number: 91K4-14150

This sign shows compliance to Canadian Regulation ICES-002 (vehicles, boats and other devices propelled by an internal combustion engine, electrical means or both).

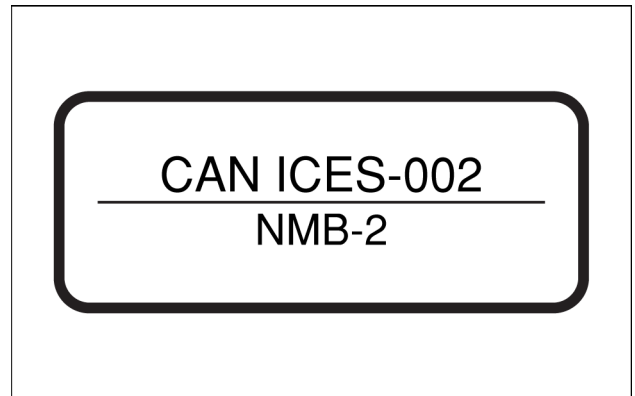

SMIL19MEX0725AA 29

(25) Biodegradable hydraulic oil

Location: this sign is located on the hydraulic tank.

Quantity: 1

This sign indicates that the vehicle can use biodegradable hydraulic oil.

Part number: 97MJ-99110

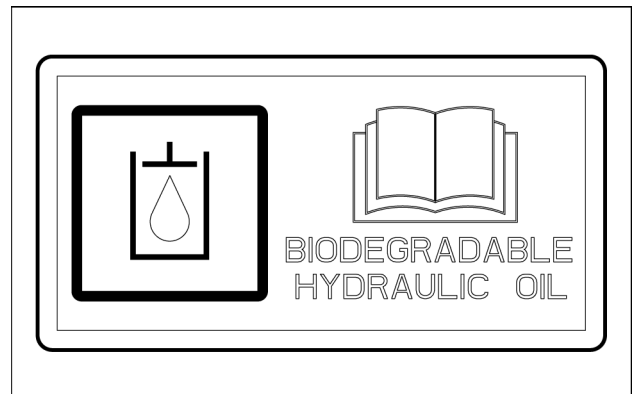

SMIL19MEX0729AA 30

Boom swing pedal

This pedal is used to swing the boom to the right-hand and left-hand direction.

Move the lock cover **(A)** to unlock position by foot.

Press the pedal to right-hand side **(1)** to swing the boom to the right-hand direction.

Press the pedal to left-hand side **(2)** to swing the boom to the left-hand direction.

NOTICE: make particular attention when swing the boom to the left-hand side: the attachment may collide with the canopy.

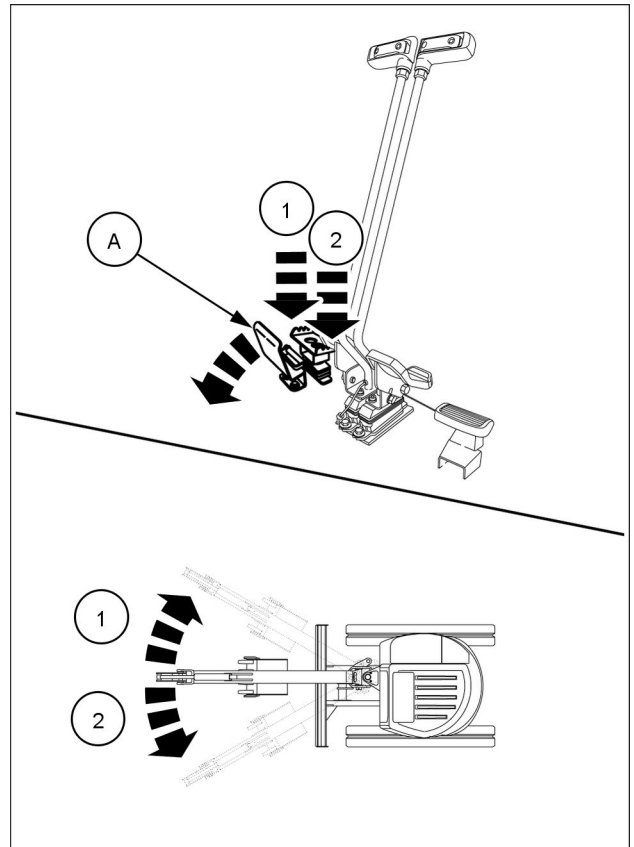

SMIL19MEX0754BA 15

Auxiliary pedal (if equipped)

The auxiliary pedal **(A)** allows to control the main auxiliary hydraulic circuit. This circuit is intended to operate attachments like hydraulic breakers or hydraulic clamshells.

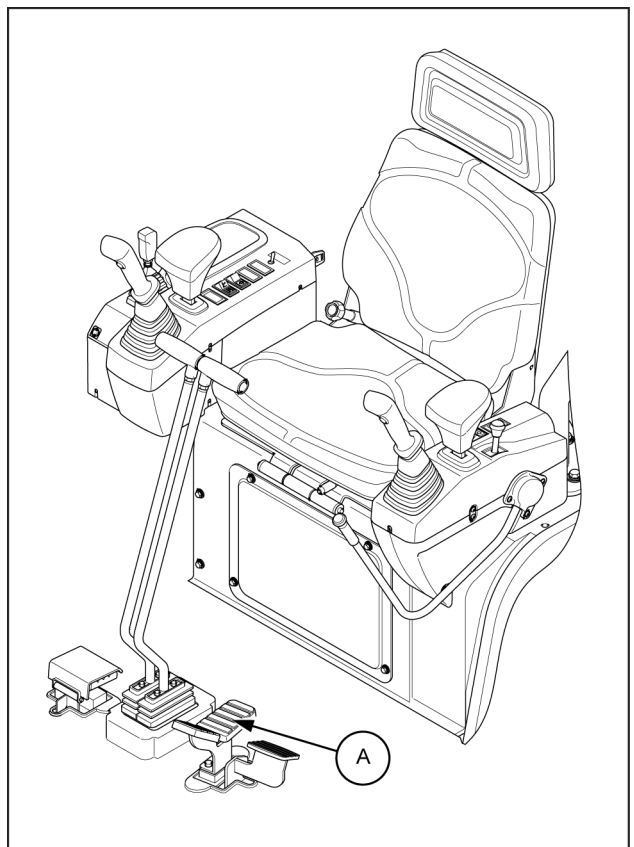

SMIL16MEX2314BB 16

NOTICE: *never stopping the machine when it is lifted from the ground, always proceed to lower it to the ground follow reverse the procedure to lift up the machine reported above.*

NOTICE: *make sure to lower the blade to the ground before stopping machine operation.*

If the engine is stopped with the blade in raised position, it is still possible to lower the blade proceeding as follows:

1. Turn the starter key to ON position.
2. Set the safety lock lever in forward position.
3. Push the blade control lever to lower the dozer blade.

Swing lock pin

Only for vehicle without internal swing motor brake.

⚠ WARNING

Misuse hazard!

Follow the operating instructions in this chapter. Any other practice that has not received the prior approval of the manufacturer is considered to be strictly forbidden.

Failure to comply could result in death or serious injury.

W0281A

The swing lock pin is located on the left-hand side of the under-carriage (A) and allows you to lock the upper-structure in forward direction of the machine.

Furthermore, it is possible to lock the upper-structure in backward direction by using the perforated plate (B) located on the right-hand side of the upper structure.

To ensure a correct upper-structure locking, align the hole of the perforated plate with the swing lock pin.

NOTICE: it is mandatory to lock the upper-structure during the machine parking, transportation on a trailer, and handling.

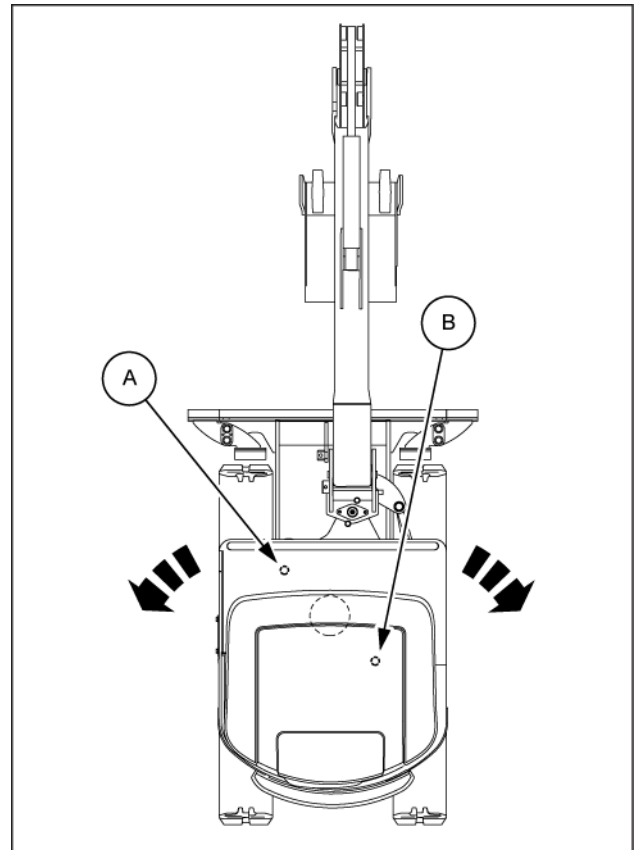

SMIL17MEX0066BB 1

Upper-structure lock

To lock the upper-structure proceed as follows:

1. Swing the upper-structure to align a perforated plate with the swing lock pin.

NOTE: it is possible to lock the upper-structure in both direction of movements of the machine.

2. Hold the pin (1) and remove the split pin (2) from the upper hole (3).
3. Raise the pin (1) and insert the split pin (2) in the lower hole (4).

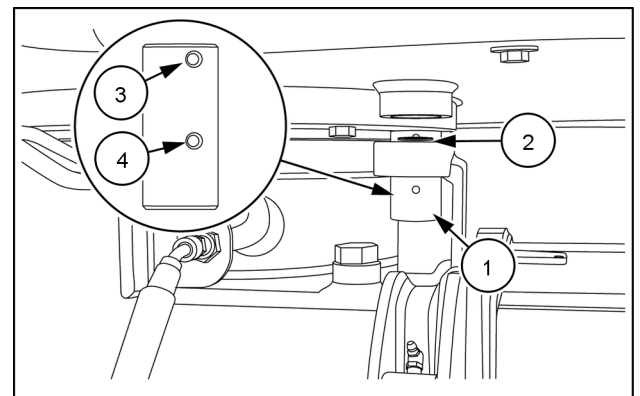

SMIL17MEX0065AA 2

Upper-structure unlock

To unlock the upper-structure proceed as follows:

1. Hold the pin (1) and remove the split pin (2) from the lower hole (4).
2. Lower the pin (1) and insert the split pin (2) in the upper hole (3).

Operating the machine on sloping ground

⚠ WARNING

Driving hazard!

Hillside operations can be dangerous. Rain, snow, ice, loose gravel, or soft ground, etc. can change the ground conditions. You must make a judgment if it is safe to operate your machine on any hillside or ramp.

Failure to comply could result in death or serious injury.

W0144A

⚠ WARNING

Overturning hazard!

Before parking the machine, make sure the ground is stable. Plan the worksite so that the ground is flat, hard, and level.

Failure to comply could result in death or serious injury.

W0258A

When working on a sloping ground, the machine becomes unstable, unbalanced, and difficult to control. Therefore, the following operating prescriptions shall be strictly respected.

If the intended job site is located on a sloping ground, a hard horizontal area shall be prepared as operating base for the machine. Never work on slopes steeper than 10° .

Travel along slopes up to 20° is allowed only to reach a specific work area. Refer to "Machine travel - Precautions for travelling on slopes" in order to understand proper operating practices and precautions for traveling along slopes.

NOTICE: The machine grade ability is 30° (58%). Never operate the engine when the incline of the machine is 30° or more. The engine or the hydraulic system may be damaged.

Work with the undercarriage oriented along the slope, never across. Always keep the travel reduction gears pointing down towards the bottom of the slope. Lower and indent the blade into the ground.

Make sure to define a safe working area around the machine, which shall be equal to the maximum reach of the front equipment plus **2 m (6.6 ft)**. It is recommended to have a supplementary guiding operator on the ground out of the safe working area, in order to provide proper indications and prompt warnings to the machine operator.

Maintain the maximum engine speed.

Make sure that the low speed travel mode is selected.

Operate the control levers smoothly in order to prevent sudden movements that may cause the machine to slip or tip over.

Avoid full boom raising, as well as swing operation towards the bottom of the slope with the bucket loaded, or swing operation with any heavy attachment installed, in order not to affect the balance of the machine.

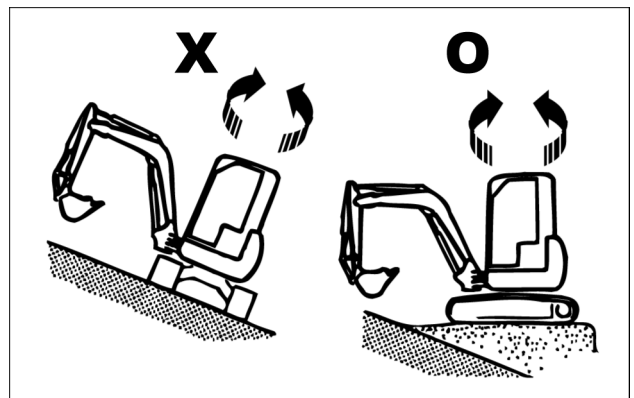

SMIL16MEX3166AB 2

4 - OPERATING INSTRUCTIONS

If you travel on a slope with the machine higher at one side, this will risk to damage the rubber track. Both machine sides must travel at the same level.

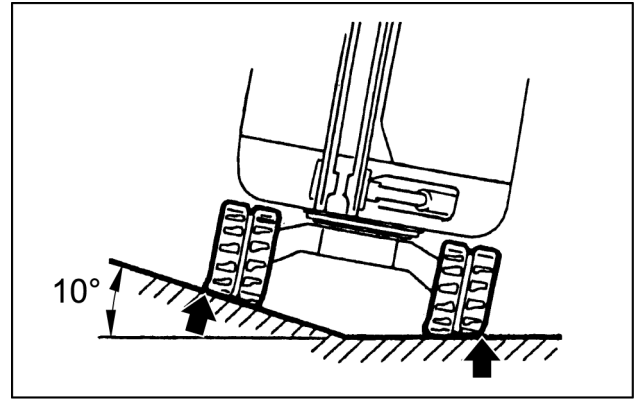

LELI11E0269AB 11

Do not change the direction of the machine with the rubber tracks positioned on earth heaps, as this could cause the rubber track to come off or get damaged.

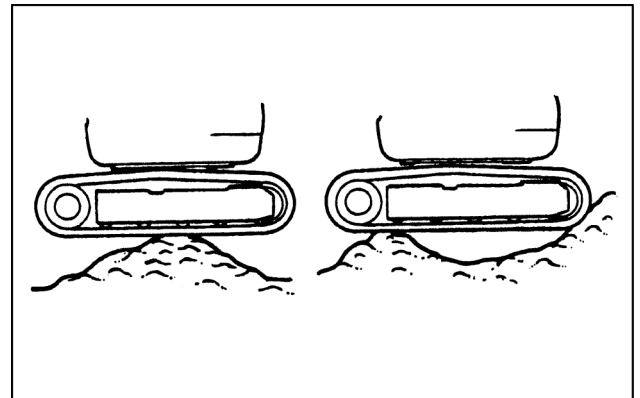

LELI11E0270AA 12

5 - TRANSPORT OPERATIONS

Road transport

Loading the machine onto a transport trailer

⚠ WARNING

Improper operation or service of this machine can result in an accident. Assign a supervisor to direct worksite operations. Agree on all safety measures, procedures, and suitable hand signals. Failure to comply could result in death or serious injury.

W0287A

⚠ WARNING

Transport hazard!
The machine can slip or fall from a ramp or trailer. Make sure the ramp and trailer are not slippery. Remove all oil, grease, ice, etc. Move the machine on or off the trailer with machine centered on the trailer or ramp. Failure to comply could result in death or serious injury.

W0152A

Make sure to check the total weight, length, width and height of the machine to be transported. Refer to Chapter 8.

Make sure to use a trailer with a rated capacity and dimensions sufficient to transport the machine. If a rear loading type trailer is used for road transport, make sure that ramps are available to climb onto the trailer bed. Use ramps which have sufficient width, length, thickness and strength. The ramp slope should be **15°** or less.

Investigate beforehand the conditions of the road to be traveled, weight and size limits, and special local traffic regulations. Obtain any permits required from proper government agencies for machine transportation.

Trailer setup

1. Position the trailer on firm and level ground.
2. Put blocks to the tires of the trailer to prevent trailer from moving.
3. If a rear loading type trailer is used for road transport, prepare the loading ramps. If the ramps are included in the trailer frame, lower them to the ground. If the ramps are external to the trailer, match them to the rear edge of the trailer avoiding any bump between trailer bed and external ramps.

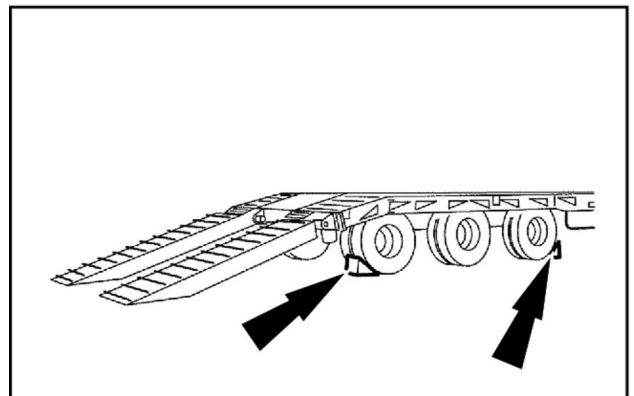

SMIL13CEX2717AB 1

Machine setup

1. Clean the machine undercarriage and tracks to prevent mud or debris from skidding during transport.
2. Select the low travel speed.
3. Lock the boom swing pedal.
4. Fully raise the dozer blade.

CLICK HERE TO **DOWNLOAD** THE COMPLETE MANUAL

- Thank you very much for reading the preview of the manual.
- You can download the complete manual from: www.heydownloads.com by clicking the link below



- Please note: If there is no response to CLICKING the link, please download this PDF first and then click on it.

CLICK HERE TO **DOWNLOAD** THE COMPLETE MANUAL

Attachment

- Check that the cylinders are not leaking oil.
- Check the condition of all lines.
- Check the condition of the bucket teeth.

After starting the engine

- Did the engine start correctly? Are the exhaust fumes normal? Any strange noises?
- Check for abnormal noise on the hydraulic components.
- Check the components for signs of leaking oil or water.
- Check the audible alarm devices, working lights and windshield wipers.
- Check that all circuits (travel, swing and tool) are functioning correctly.

NOTICE: *if the slightest defect is found, repair it immediately before using the machine or consult your NEW HOLLAND CONSTRUCTION Dealer.*

5. Otherwise, if the machine is equipped with the proportional switch on the right-hand control lever, slide it to left-hand and right-hand three times approximately to release the pressure.

NOTE: *this procedure does not completely release the pressure, so when operate on the hydraulic system, loosen the connections slowly and do not stand in the direction where the oil drains out.*

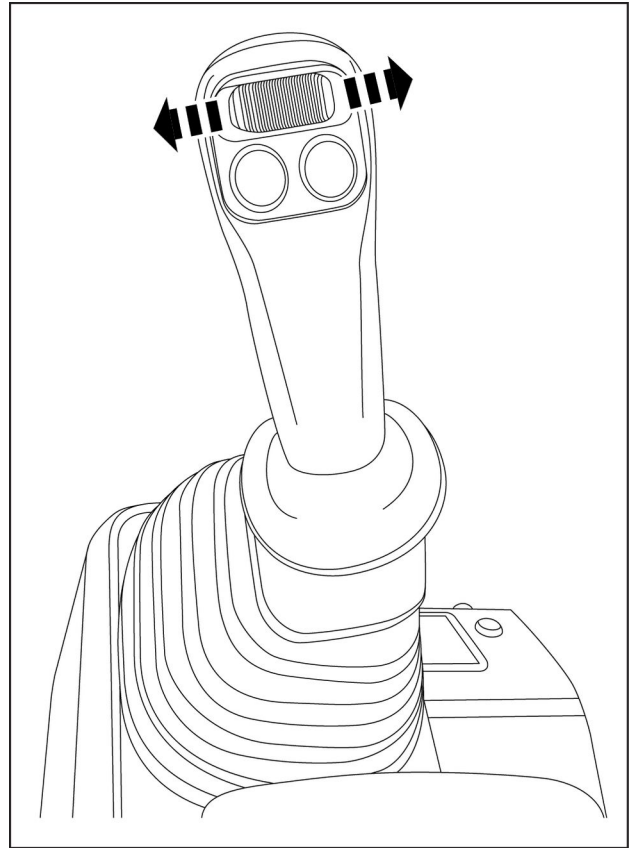

SML16MEX1265BA 7

Hydraulic oil level

⚠ WARNING

Burn hazard!

Before performing any service on the hydraulic system, you must allow it to cool. Hydraulic fluid temperature should not exceed 40 °C (104 °F).

Failure to comply could result in death or serious injury.

W0241A

Check the hydraulic oil level every **10 h** or every day

Fluid: **PREMIUM HYDRAULIC OIL HV46 MULTI-GRADE ANTIWEAR**

1. Park the machine on a flat and level place, and arrange the attachment as shown in the figure. Stop the engine, and remove the starter key.

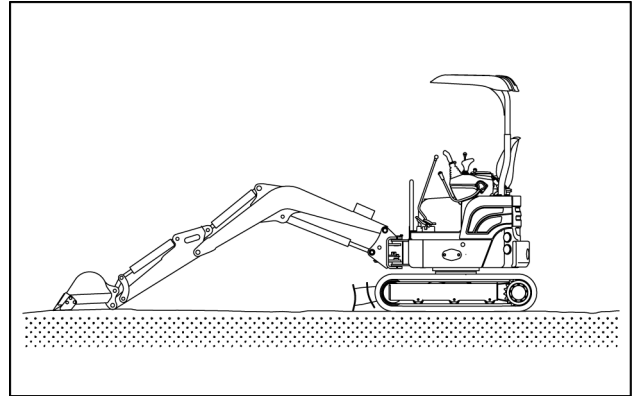

SMIL16MEX2502AA 1

2. Open the door located over the right-hand side of the machine to access the hydraulic oil tank (1). The oil level is normal if between the red lines of the level gauge (3).
3. If the hydraulic oil level is not in the correct range proceed as follows:
 - Release all pressure in the hydraulic tank. Refer to page 6-10.
 - Clean the cap (2) and the area around the cap.
 - Remove the cap (2), and supply hydraulic fluid to the hydraulic oil tank.
 - Install the cap (2).

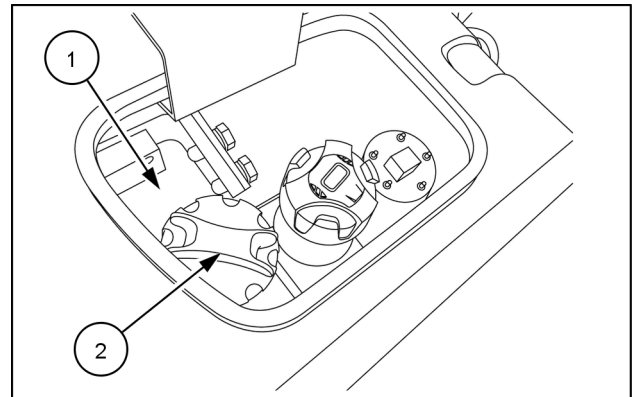

SMIL16MEX2657AA 2

NOTICE: make sure that no contaminant (water, sand etc.) enters the reservoir during filling.

4. Start the engine after filling and operate the work equipment several times.
5. Check the oil level after engine stops. Close the side hood.

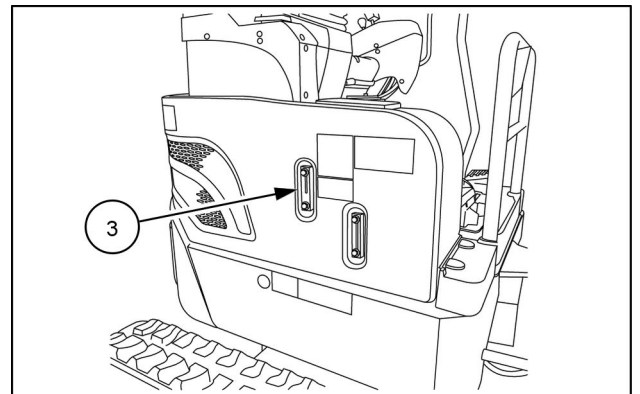

SMIL16MEX2658AA 3

Every 100 hours

Fuel filter water separator

Clean the element of the fuel filter water separator every **100 h**.

To clean the element of the fuel filter water separator, refer to page **6-24**.

Hydraulic oil return filter

⚠ WARNING

Burn hazard!

Before performing any service on the hydraulic system, you must allow it to cool. Hydraulic fluid temperature should not exceed 40 °C (104 °F).

Failure to comply could result in death or serious injury.

W0241A

⚠ WARNING

Pressurized system!

Never attempt to drain fluids or remove filters when the engine is running. Turn off the engine and relieve all pressure from pressurized systems before servicing the machine.

Failure to comply could result in death or serious injury.

W0905A

Replace the hydraulic oil return filter every **250 h**.

NOTICE: when using the breaker, reduce the interval of the hydraulic oil return filter replacement. Refer to page **Hydraulic oil - breaker/auger**.

1. Release all the pressure in the hydraulic tank. Refer to page **6-10**.
2. Clean the top of the hydraulic oil tank, and clean the cover of the return filter.
3. Remove the bolts (1), the cover (2) and the O-ring (3).
4. Remove the return filter (4) and install the new one.
5. Check the O-ring (3), and replace it if any wear or damage is found.
6. Install the cover (2) and lock with the bolts (1). Tighten the bolts (1) to **26.4 – 40.3 N·m (19.5 – 29.7 lb ft)**.
7. Check the hydraulic fluid level, and fill it if necessary.

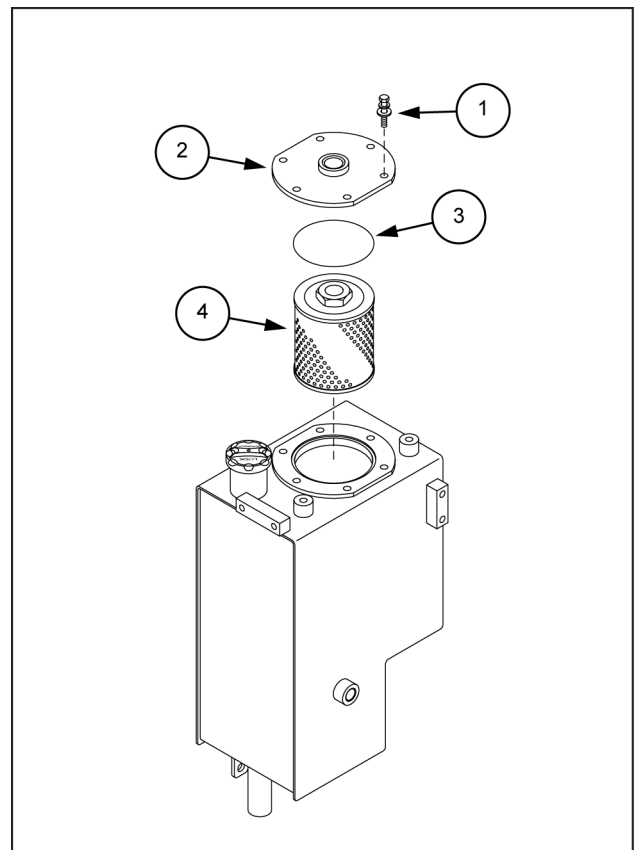

SMIL16MEX2523BB 1

Every 1000 hours

Travel reduction gears

Replace the travel reduction gears oil every **1000 h** (after the break-in period).

Lubricant: **HYPOID GEAR OIL EXTREME PRESSURE 80W-90**

Quantity: **0.33 L (0.09 US gal)** (per travel reduction gear)

1. Park the machine on flat, horizontal ground.
2. Move the machine so that the drain plug **(1)** comes down to the lowest position.
3. Stop the engine, and remove the starter key.
4. Place a container with a capacity of **1 L (0.26 US gal)** under the travel reduction gear.
5. Remove the level plug **(2)**.
6. Remove the drain plug **(1)**.

NOTE: check the condition of the drained oil. If there are pieces of metal or foreign objects in the oil, consult the **NEW HOLLAND CONSTRUCTION** dealer.

7. Replace the O-ring seal of the drain plug **(1)**.
8. Insert the drain plug **(1)** with seal tape wrapped around it.
9. Add oil through fill port **(3)** until the oil comes up to the bottom edge of the port **(2)**.
10. Replace the O-ring seal of the level plug **(2)** and the O-ring seal of the fill plug **(3)**. Insert the level plug **(2)** with seal tape wrapped around it, then do the same for the fill plug **(3)**.
11. Repeat steps **2** to **10** for the other travel reduction gear.
12. Run the machine slowly to check that there are no leaks.

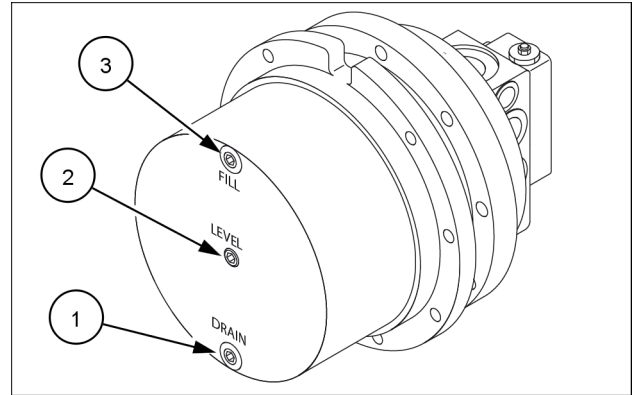

SMIL16MEX0442AA 1

Every 3000 hours

Injection timing

Check the injection timing every **3000 h**.

NOTICE: to check the injection timing refer to your **NEW HOLLAND CONSTRUCTION** dealer.

Injection pump

Check the injection pump every **3000 h**.

NOTICE: to check the injection pump refer to your **NEW HOLLAND CONSTRUCTION** dealer.

Starting up the machine after storage

▲ WARNING

Unexpected machine movement!
Before starting the engine, make sure all controls are in the neutral position.
Failure to comply could result in death or serious injury.

W0311A

▲ WARNING

Inhalation hazard! Risk to operators and bystanders.
Avoid running the engine in confined areas. Make sure there is adequate ventilation at all times.
Failure to comply could result in death or serious injury.

W0156A

1. Drain the fuel tank and clean the fuel filter. Replace the filter element as required.
2. Fill the fuel tank with suitable fuel.
3. Install the batteries or reconnect the cable to the negative (-) terminal.
4. Grease the machine thoroughly.
5. Check the condition of the fan drive belt and replace it if necessary.
6. Check the condition of the air conditioning drive belt and replace it if necessary (if equipped).
7. Check the cooling system level and add more coolant if necessary.
8. Check the hydraulic fluid level, and supply it as necessary.
9. Check the gear oil level of the travel reduction gear and that of the swing reduction gear, and supply it as necessary.
10. Clean the cylinder rod.
11. Remove the lid of the air cleaner inlet and that of the exhaust pipe.
12. Remove the "Do not operate" label, and start the engine following the engine starting procedure.
13. Check all the indicators and lights carefully.

NOTICE: *check the machine and the engine for leaks or for any parts that are broken, defective or missing.*

Weights

Machine

Operating weight (*)	1770 kg (4079 lb)
----------------------	--------------------------

Components

Upperstructure assembly	923 kg (2035 lb)
Main frame weld assembly	160 kg (353 lb)
Engine assembly	75 kg (165 lb)
Main pump assembly	13 kg (29 lb)
Main control valve assembly	14 kg (31 lb)
Swing motor assembly	15 kg (33 lb)
Hydraulic oil tank assembly	17 kg (37.5 lb)
Fuel tank assembly	5 kg (11 lb)
Boom swing post	35 kg (77 lb)
Counterweight	188 kg (414.5 lb)
Canopy assembly	40 kg (88 lb)
Front guard	8 kg (18 lb)
Lower chassis assembly	550 kg (1213 lb)
Track frame weld assembly	185 kg (408 lb)
Swing bearing	20 kg (44 lb)
Travel motor assembly	18 kg (40 lb)
Hydraulic swivel	14 kg (31 lb)
Track recoil spring	11 kg (24 lb)
Idler	15 kg (33 lb)
Track roller	5 kg (11 lb)
Sprocket	4 kg (9 lb)
Rubber track (230 mm (9.1 in))	59 kg (130 lb)
Dozer blade assembly	70 kg (154 lb)
Front attachment assembly (1.8 m (70.87 in) boom, 0.96 m (37.80 in) arm, 0.04 m³ (0.05 yd³) SAE heaped bucket)	227 kg (500 lb)
1.8 m (70.87 in) boom assembly	70 kg (154 lb)
0.96 m (37.80 in) arm assembly	35 kg (77 lb)
0.04 m³ (1.41 ft³) SAE heaped bucket	40 kg (88 lb)
Boom cylinder assembly	17 kg (37 lb)
Arm cylinder assembly	15 kg (33 lb)
Bucket cylinder assembly	11 kg (24 lb)
Bucket control link assembly	10 kg (22 lb)
Dozer cylinder assembly	8 kg (18 lb)
Boom swing cylinder assembly	10 kg (22 lb)
Extension cylinder assembly	8 kg (18 lb)

(*) Canopy, boom, arm, bucket, lubricant, coolant, full fuel and hydraulic oil, without quick coupling system, rubber track. Weight tolerance : $\pm 3\%$.

Precautions while operating the hydraulic breaker

Avoid hitting objects with breaker. The breaker is heavier than the bucket and lowers faster. This may cause damages to the breaker, attachment, and upperstructure. Always lower the breaker slowly until the chisel point touches the object to be broken before starting breaker operation.

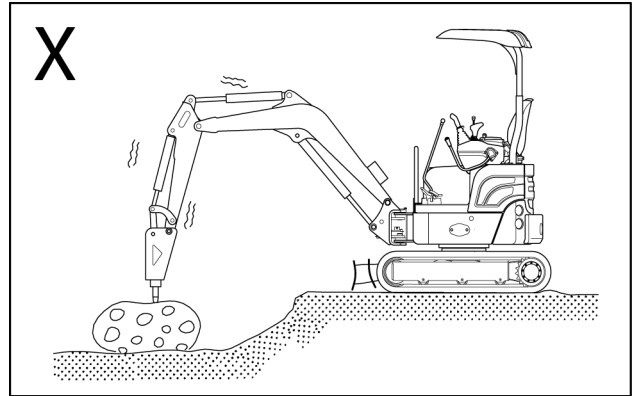

SMIL16MEX2539AA 9

Do not use the hydraulic breaker and/or swing function to push objects as damage to the attachment may result.

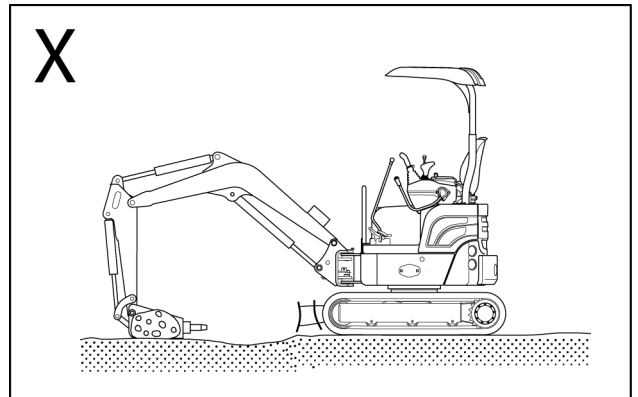

SMIL16MEX2540AA 10

Do not operate the breaker with the excavator cylinders fully extended or retracted to avoid attachment and/or cylinder damage.

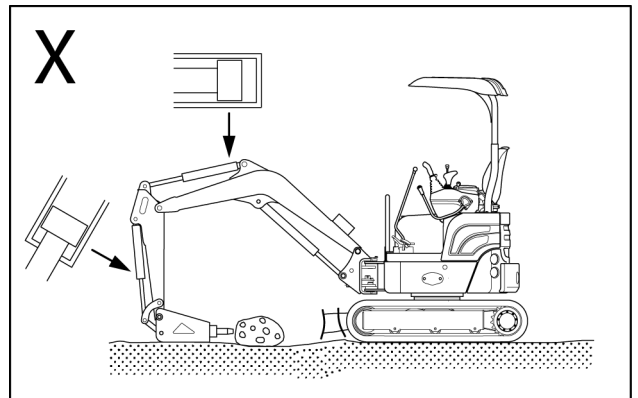

SMIL16MEX2541AA 11

Stop working if hydraulic hoses look abnormally bent. Contact your authorized Dealer.

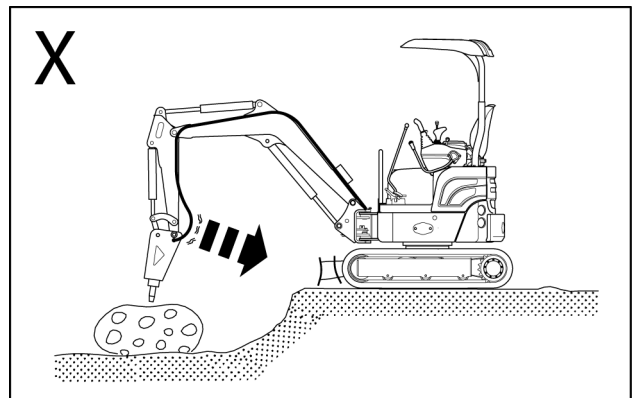

SMIL16MEX2542AB 12

The auger pendulum mount assembly consist of the following items:

- Drive unit (1)
- Pendulum mount (2)
- Bit (5)
- Auger bit extension (6): this component, not shown in figure, must be installed between drive unit (1) and the bit (5).

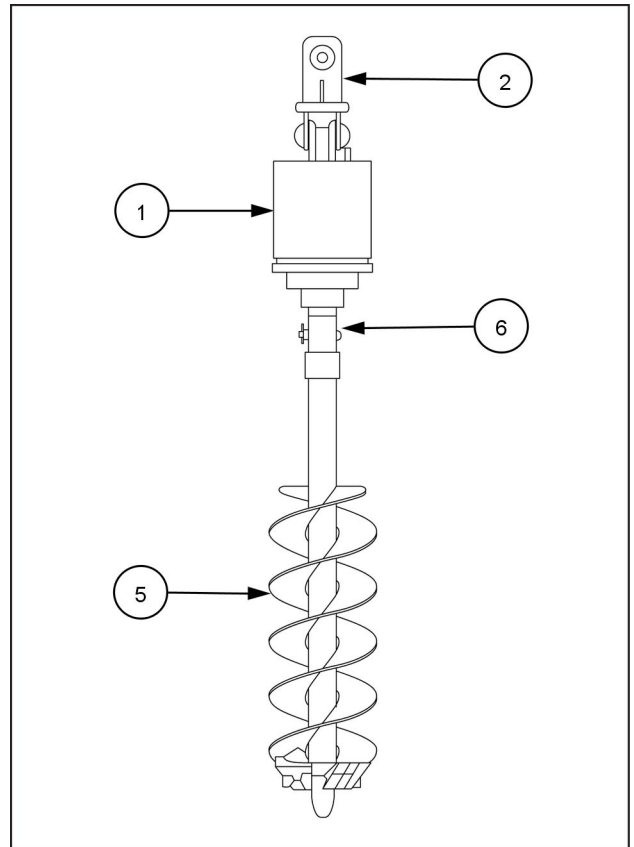

SMIL17MEX3033BA 37

The auger cradle mount bracket assembly consist of the following items:

- Drive unit (1)
- Cradle mount bracket (3)
- Pin, bushing and insert kit (4)
- Bit (5)
- Auger bit extension (6): this component, not shown in figure, must be installed between drive unit (1) and the bit (5)
- Adapter plate (7): this component, not shown in figure, must be used to engage the cradle mount bracket (3) with Klac coupler.

NOTE: the adapter plate (7) is for Klac coupler applications only.

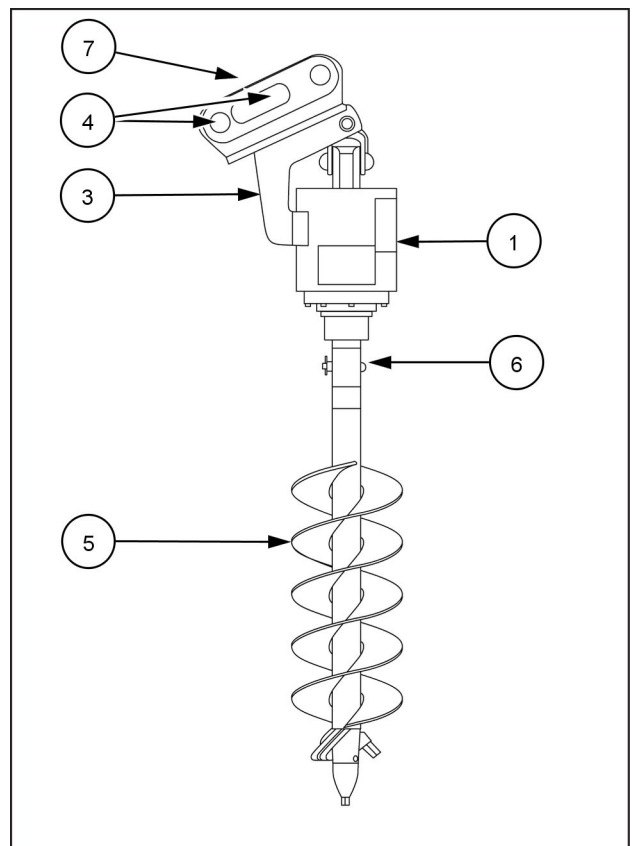

SMIL17MEX3034BA 38

3. Extend the bucket cylinder (curl in) until the rear pin of the attachment is firmly seated in the coupler.
4. Stop the engine and get out of the machine.

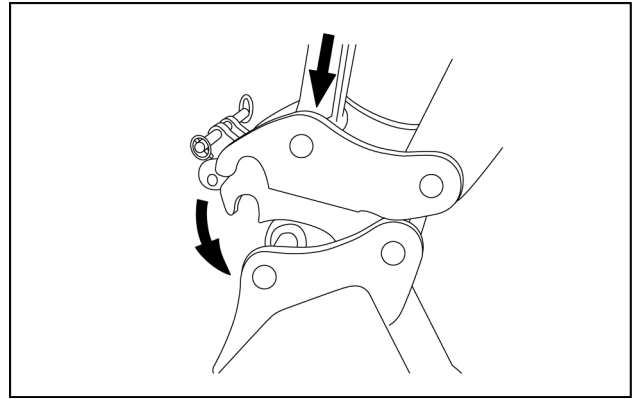

SMIL17MEX2814AA 2

5. Insert the release bar (3) and rotate the locking hooks upwards slightly.
6. Remove the retainer pin (4) and the locking pin (2).

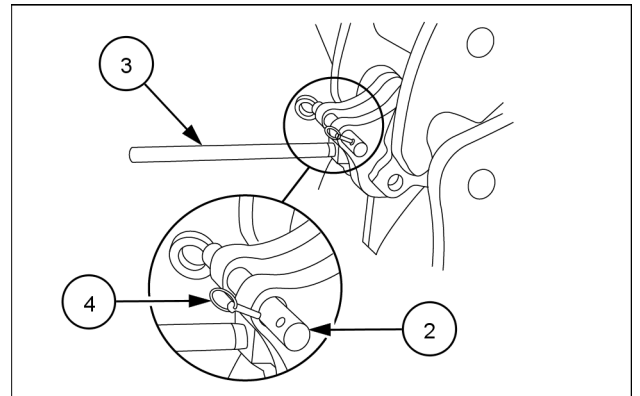

SMIL17MEX2815AA 3

7. Use the release bar (3) to rotate the locking hook downward to engage the attachment rear pin.
8. Install the locking pin (2) and the retainer pin (4).
9. Remove the release bar from its seat.

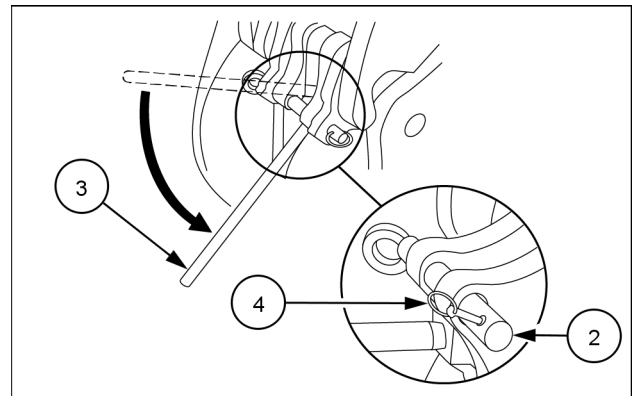

SMIL17MEX2816AA 4

CLICK HERE TO **DOWNLOAD** THE COMPLETE MANUAL

- Thank you very much for reading the preview of the manual.
- You can download the complete manual from: www.heydownloads.com by clicking the link below



- Please note: If there is no response to CLICKING the link, please download this PDF first and then click on it.

CLICK HERE TO **DOWNLOAD** THE COMPLETE MANUAL