

ORIGINAL INSTRUCTIONS

# OPERATOR'S MANUAL

---

**B95C**

**B95C TC**

**B110C**

**Tier 4B (final)**

Tractor Loader Backhoe

**Part number 47987572**

2<sup>nd</sup> edition English

April 2016

*Replaces part number 47800824*



CLICK HERE TO **DOWNLOAD** THE COMPLETE MANUAL

- Thank you very much for reading the preview of the manual.
- You can download the complete manual from: [www.heydownloads.com](http://www.heydownloads.com) by clicking the link below



- Please note: If there is no response to CLICKING the link, please download this PDF first and then click on it.

CLICK HERE TO **DOWNLOAD** THE COMPLETE MANUAL

## Spare parts

The “non-genuine” spare parts have not been checked and authorized by the manufacturer. The assembly and/or use of such products may have negative effects on the machine design features and could impair its operation safety. The manufacturer is not liable for any damage caused by “non-genuine” spare parts or accessories.

**NOTE:** *Each machine is supplied complete with a copy of this manual. Descriptions and illustrations provided herein are not binding. The manufacturer, provided that the basic characteristics of machine types described and shown in this manual remain the same, reserves the right to change components, parts and accessories supplied without any commitment to timely update this publication, and this any time it deems it convenient for improvement purposes or due to commercial or manufacturing requirements. For exact information, please consult your dealer or contact the manufacturer's branch offices, who remain at your disposal for further help.*

Constant ambient storage temperature	Minimum shelf life
<sup>1</sup> To prevent decomposition of DEF/AdBLUE®, prolonged transportation or storage above <b>25 °C (77 °F)</b> should be avoided.	
<sup>2</sup> Significant loss of shelf life: check every batch before use. See your NEW HOLLAND CONSTRUCTION dealer for more information on testing.	

**NOTE:** The main factors taken into account to define the shelf life in the table above are the ambient storage temperature and the initial alkalinity of DEF/AdBLUE®. The difference in evaporation between vented and non-vented storage containers is an additional factor.

**NOTE:** The information in this table is for reference only and has been provided by the International Organization for Standardization, Document number ISO 22241-3 Diesel engines - NO<sub>x</sub> reduction agent AUS 32 - Part 3: Handling, transportation and storage.

**NOTE:** DEF/AdBLUE® that remains in the tank of the machine after the season does not require any special precautions unless storage exceeds the shelf life table above.

Disposal

- Dispose of DEF/AdBLUE® and any filter accumulations in accordance with all applicable Federal, State, and local laws governing waste disposal.

**Hydrocarbon management**

If the engine is run at low idle speed for a prolonged period of time, hydrocarbons can accumulate in the SCR catalyst. To manage this accumulation, your machine will monitor current conditions and increase idle speed and/or activate the throttle to increase the temperature inside the SCR catalyst and eliminate the hydrocarbons.

**NOTICE:** Unless the Hydrocarbon (HC) level has reached the most critical level, running the unit under load is advantageous for quickly reducing the HC levels.

There are three messages that can be displayed to inform you that hydrocarbon management is active:

- Low Idle Increase Recommended - The engine control module desires to increase the engine speed when operating at lower temperatures or with lighter engine loads in order to elevate SCR temperatures.

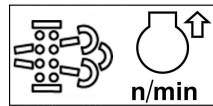

**NOTE:** This automatic engine idle speed increase is inhibited if certain features are active on the machine. For example: the transmission is in gear, or the remote hydraulics are activated.

- Low Idle Increase Active - The engine low idle speed has been increased to elevate exhaust temperatures in the SCR catalyst.

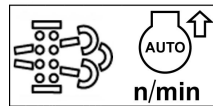

Promptly investigate any unusual smells or odors that may occur during operation of the machine.

 **General battery safety** 

Always wear eye protection when you work with batteries.

Do not create sparks or have open flame near a battery.

Ventilate the area when you charge a battery or use a battery in an enclosed area.

Disconnect the negative (-) terminal first and reconnect the negative (-) terminal last.

When you weld on the machine, disconnect both terminals of the battery.

Do not weld, grind, or smoke near a battery.



When you use auxiliary batteries or connect jumper cables to start the engine, use the procedure shown in the operator's manual. Do not short across terminals.

Follow the manufacturer's instructions when you store and handle batteries.

Battery post, terminals, and related accessories contain lead and lead compounds. Wash hands after handling. This is a California Proposition 65 warning.

Battery acid causes burns. Batteries contain sulfuric acid. Avoid contact with skin, eyes, or clothing. Antidote (external): Flush with water. Antidote (eyes): flush with water for 15 minutes and seek medical attention immediately. Antidote (internal): Drink large quantities of water or milk. Do not induce vomiting. Seek medical attention immediately.

Keep out of reach of children and other unauthorized persons.

 **Reflectors and warning lights** 

You must use flashing amber warning lights when you operate equipment on public roads.

## Support strut for loader lift arm

### **⚠ WARNING**

#### **Crushing hazard!**

If you service the machine with the loader lift arms raised, always use the support strut. Remove the retaining pin and place the support strut onto the cylinder rod. Install the retaining pin into the support strut. Lower the lift arms onto the support strut.

Failure to comply could result in death or serious injury.

W0230A

### **Machines without the Tool Carrier (TC) option**

Engage the loader arm support strut:

1. Empty the loader bucket.
2. Raise the loader lift arms to the maximum height.
3. Stop the engine and remove the starter switch key.
4. Remove the split pin (1) and the lock pin (2).

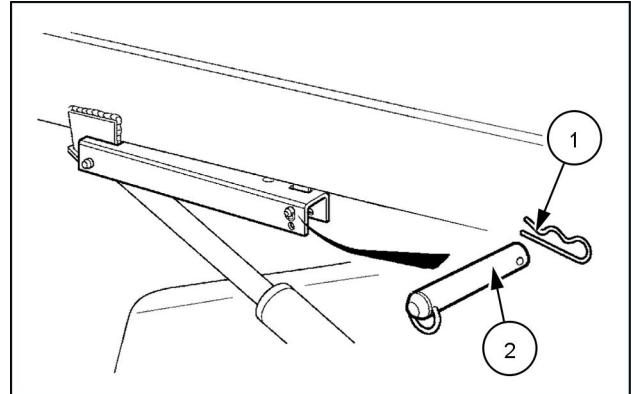

MOL112LBB0260AB 1

5. Place the strut (3) on the cylinder rod and install the pin (2) and the split pin (1) back into the holes in the strut.
6. Lower the loader attachment until the safety strut is firmly against the cylinder.

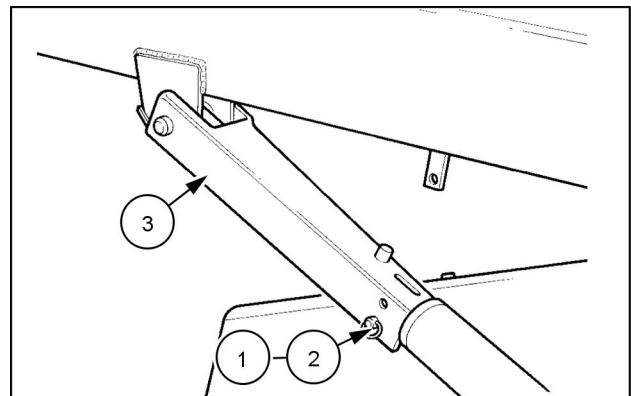

MOL112LBB0261AB 2

Disengage the loader arm support strut:

1. Raise the loader lift arms to the maximum height.
2. Stop the engine and remove the starter switch key.
3. Remove the split pin (1) and the lock pin (2).

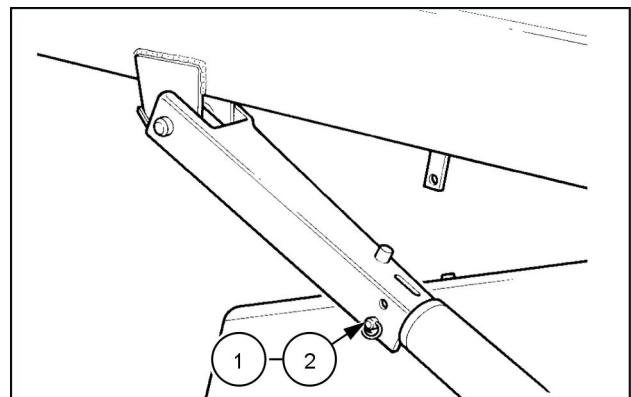

MOL112LBB0262AB 3

Extend telescopic dipper (if fitted)

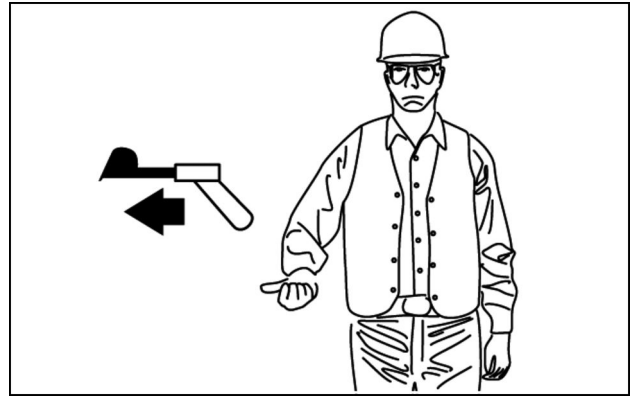

LEEN12T0538AA 24

### (11) Hydraulic oil tank

This safety sign can be located on the hydraulic tank on the right hand side of the machine (See Image 2)

**Part numbers:**

English: 85804341

Make sure that you only fill a reservoir bearing this safety sign with hydraulic fluid.

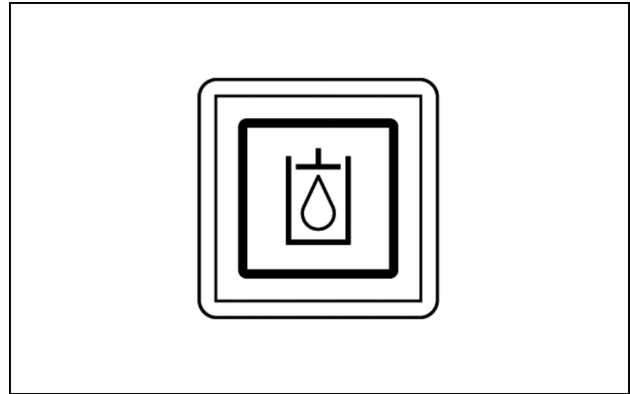

LEEN12T0726AA 13

### (12) Loader lift arm safety support

This safety sign can be located on the left loader arm (See Image 2)

**Part numbers:**

English: 85821921

French: 85828084

Spanish: 85828085



85821921 14

**⚠ WARNING**

Crush hazard!

Use lift arm support device when servicing machine with raised loader

1. Empty loader bucket, raise loader lift arms to maximum height. Stop engine.
2. Remove rear pin in support device. Lower support device onto cylinder rod.
3. Install rear pin in support device.
4. Slowly lower lift arms onto support device.

Injury or DEATH could occur IF THIS PROCEDURE is not followed and loader lift arms are lowered by accident.

### (13) Fuel tank, low sulfur diesel fuel

This safety sign can be located on the fuel tank (See Image 2)

**Part numbers:**

English: 84319035

This safety sign indicates to make sure that the tank bearing this safety sign contains low sulfur diesel fuel only.

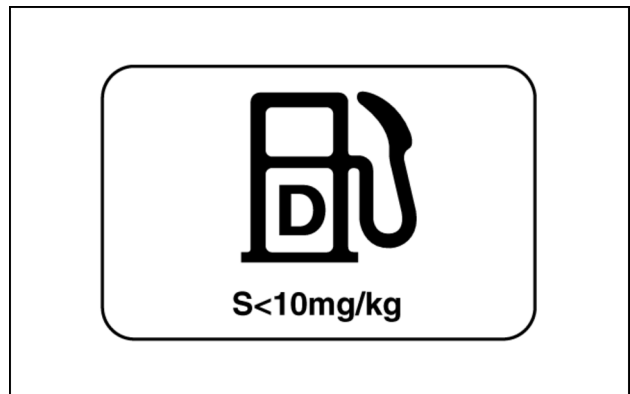

LEEN12T0729AA 15

## Rear windows

### Opening

Release the locks (1) and swing the window inwards with the handles.

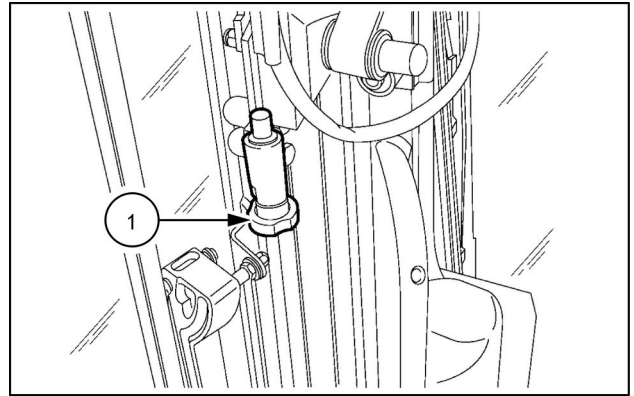

MOL112LBB0136AB 5

Bring the window into horizontal position and lock it with the latches (2).

**NOTICE:** Make sure the window is completely locked.

### Closing

Release the latches (2) and tilt into lower position with the handles.

Lock the window with the locks (1).

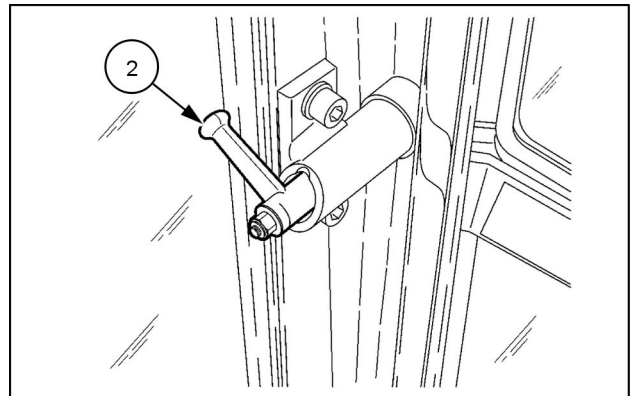

MOL112LBB0137AB 6

## Pedal controls

### Foot throttle

The foot throttle (1) is under the steering wheel. Use the foot throttle to increase or decrease engine speed when traveling. Use the foot throttle to increase or decrease power for loader operations.

- Press the pedal to increase the engine speed.
- Release the pedal to reduce the engine speed.

**NOTE:** This pedal is coupled with the hand throttle. Before using the pedal, make sure that the hand throttle is in the minimum speed position.

**NOTICE:** Never use this pedal when working with the backhoe attachment.

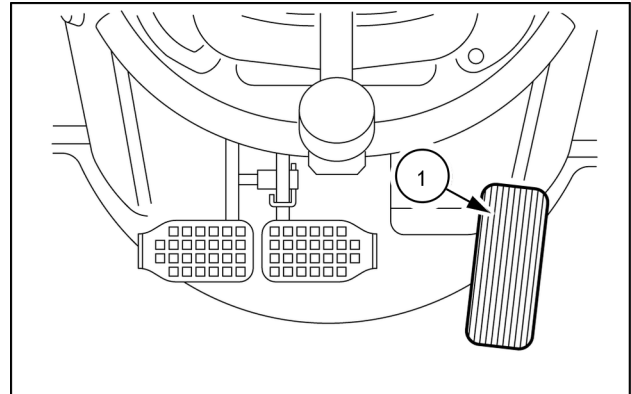

MOL112LBB0125AB 1

### Brake pedals

The two brake pedals (1) are equipped with a locking system (2).

Unlock the brake pedals to assist with turns.

- Press the left-hand pedal to help turn the machine to the left.
- Press the right-hand pedal to help turn the machine to the right.

Braking with one pedal only should only be carried out at low speed.

**NOTE:** Only use the one pedal braking when traveling at low speeds. Lock the service brake pedals together for uniform braking and maximum stopping ability.

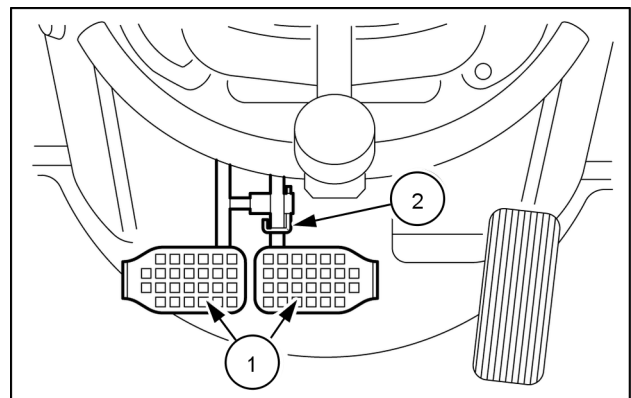

MOL112LBB0128AB 2

### **▲** WARNING

**Loss of control hazard!**

**Brake pedals shall be locked together for road travel. This ensures uniform brake application and maximum stopping ability.**

**Failure to comply could result in death or serious injury.**

W0308A

To lock the two pedals together, tilt the latch (2) so it engages on the right-hand pedal.

### Loader attachment control lever

1. Loader attachment control lever
2. Transmission disconnect button
3. Horn button
4. Roller for the proportional control of 4 x 1 loader bucket

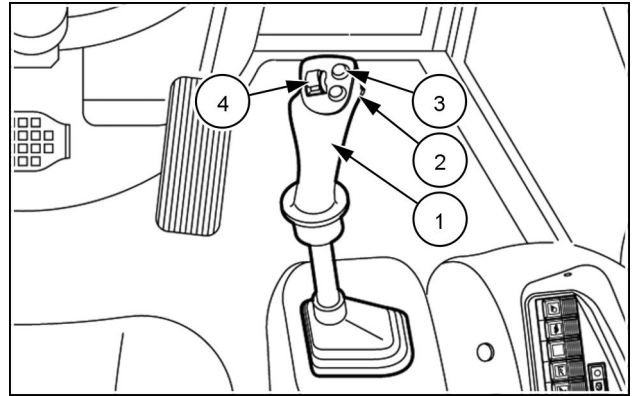

LEEN12T0548AA 3

### Differential lock switch

#### **⚠ WARNING**

**Loss of control hazard!**  
**Avoid using differential lock at speeds above 8 km/h (5 mph). Never use at speeds above 15 km/h (9 mph) or at any time when turning the machine.**  
**Failure to comply could result in death or serious injury.**

W0334A

To activate the differential lock, carry out the following procedure:

- before engaging the differential lock make sure neither rear wheel is spinning freely.
- to engage the differential lock, press the switch **(1)**.
- to disengage the differential lock, release the switch **(1)**.

The differential lock effectively places both rear wheels into a direct drive, this action stops one rear wheel spinning.

The lock will remain engaged until either of the foot brakes are applied and the machine stops or by disengaging the switch.

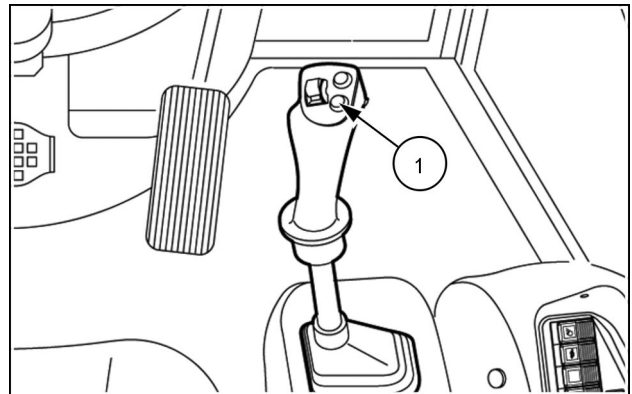

LEEN12T0549AA 4

**Air filter restriction**



Warning lamp. Illuminates and a one second audible alarm sounds when, with the engine running, the air filter element is restricted and requires service. Clean or replace the primary filter and/or replace the secondary filter when this lamp illuminates.

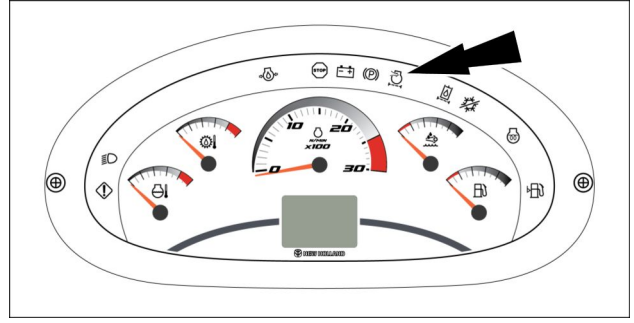

RAIL15TLB0133AA 7

**Hydraulic filter**



Warning lamp. Illuminates when, with the engine running, the hydraulic filter is restricted and requires service.

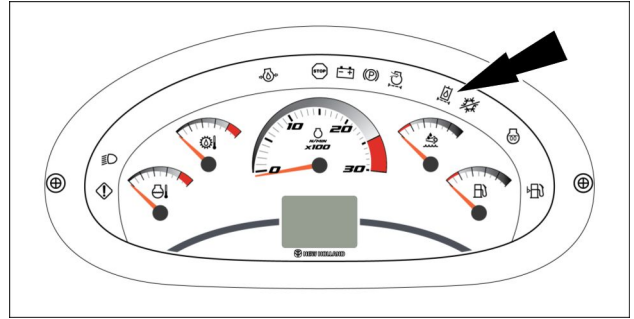

RAIL15TLB0133AA 8

**Air-conditioning system pressure**



Indicator lamp. Illuminates when the air-conditioner stops working due to refrigerant pressures that are too high.

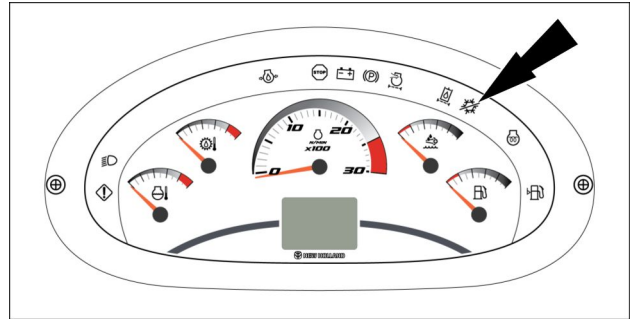

RAIL15TLB0133AA 9

**Engine glow plugs**



Indicator lamp. Illuminates when, with the key switch in the ON position, the engine glow plugs are active due to cold temperatures. Wait until the lamp goes off before turning the key switch to the START position.

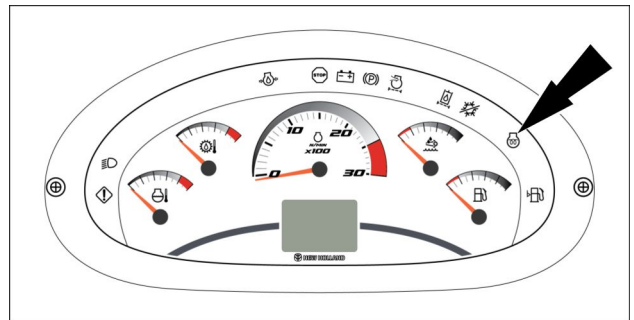

RAIL15TLB0133AA 10

**Low fuel level**

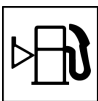

Warning lamp. Illuminates and a one second audible alarm sounds when the fuel level is low.

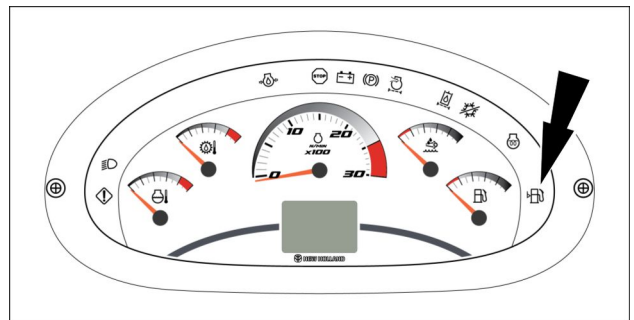

RAIL15TLB0133AA 11

## **DEF/AdBlue® quality and SCR system technical faults, failures, and engine power loss levels**

**NOTE:** You can restart the engine and receive full engine power up to two times at any point after the machine detects a fault. However, if the machine detects the same fault within 40 operating hours, torque will be reduced to 50% and the engine will be reduced to idle immediately. If you attempt a third restart, the engine will be locked at 50% torque and engine idle. Contact your NEW HOLLAND CONSTRUCTION dealer to reset the engine restart counter and resolve the fault causing the loss of productivity.

### **Resetting the Selective Catalytic Reduction (SCR) system**

For DEF/AdBlue® storage tank fluid level faults, failures that can cause engine power loss:

- The DEF/AdBlue® tank level must be raised above **20 %** total volume.
- The key switch must be cycled to the Off position or throttle returned to low idle position.

For DEF/AdBlue® quality and SCR system technical faults, failures that can cause engine power loss:

- To fully reset the system, the component/failure causing the fault must be repaired or replaced.
- Please contact your authorized NEW HOLLAND CONSTRUCTION dealer for service.

**Unlock the boom (hydraulically) if applicable**

1. Start the machine.
2. Place the direction control lever in NEUTRAL position.
3. If applicable, place gearshift control lever in the NEUTRAL position.
4. Turn the seat into the backhoe operation position.
5. Remove the swing lock pin and place it in the storage position.
6. Lower the stabilizers to the ground so that the rear tires are just off the ground.
7. Place the switch **(1)** in the OFF position. The indicator lamp **(2)** (mechanical backhoe models) or the indicator lamp **(3)** (pilot backhoe models) turns OFF.
8. Lower the boom.
9. If applicable, remove the extendable dipper lock pin **(B)** and place it in the storage position **(A)**.

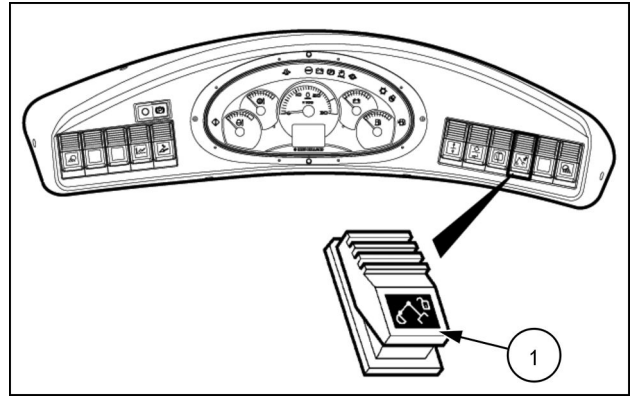

LEEN12T0646AA 4

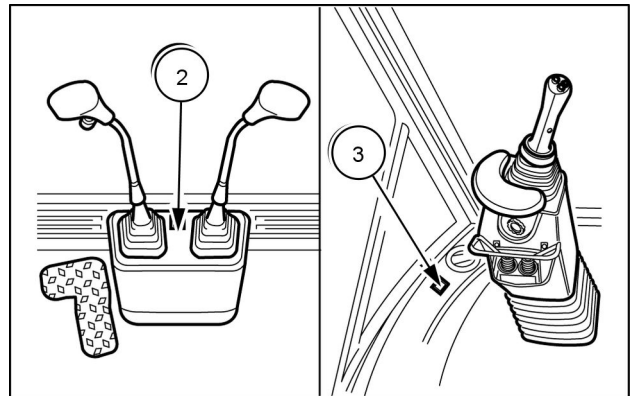

MOL112LBB0249AB 5

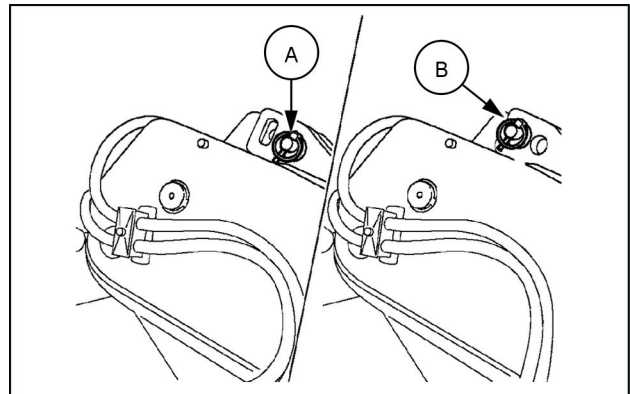

MOL112LBB0244AB 6

### Telescopic dipper mechanical control pedal (if fitted)

This pedal **(A)** has three positions:

Position “0”: Neutral. This position enables the movement of the telescopic dipper to be stopped.

The pedal automatically returns to this position as soon as it is released.

Position “1”: The telescopic dipper extends.

Position “2”: The telescopic dipper retracts.

Before using this pedal make sure that the telescopic dipper is mechanically unlocked.

**NOTE:** Operating the backhoe attachment control levers and this pedal simultaneously will enable numerous possibilities of progressive functioning.

### Auxiliary attachment control pedal (optional)

This pedal **(1)** is located to the right of the backhoe attachment controls and is used for operating auxiliary attachment, such as a hydraulic hammer.

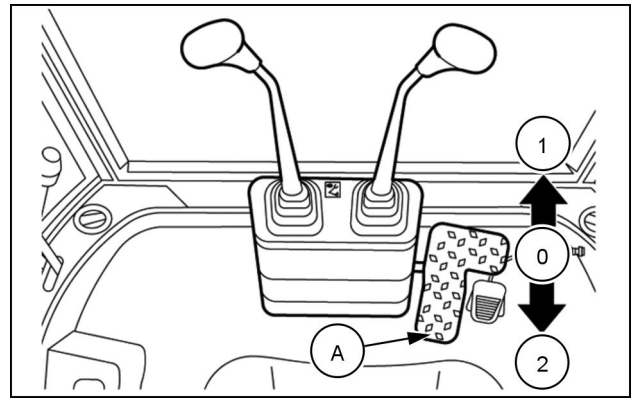

LEEN12T0802AA 6

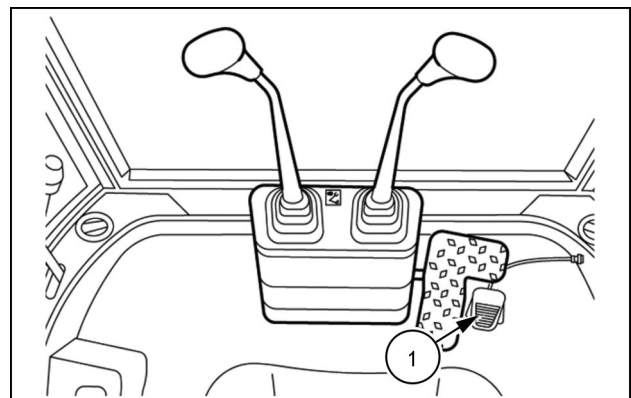

LEEN12T0803AA 7

**Air-Conditioning system (Optional)**

**⚠ WARNING**

**Explosion hazard!**  
**Air-conditioning refrigerant boils at -12 °C (10 °F)!**  
**-NEVER** expose any part of the air-conditioning system to a direct flame or excessive heat.  
**-NEVER** disconnect or disassemble any part of the air-conditioning system.  
 Discharging refrigerant gas into the atmosphere is illegal in many countries.  
 Failure to comply could result in death or serious injury.

W0340A

**⚠ WARNING**

**Escaping refrigerant may cause frostbite!**  
**If you get refrigerant on your skin:**  
**-Warm** the area with your hand or lukewarm water, 32 - 38 °C (90 - 100 °F).  
**-Cover** the area loosely with a bandage to protect the area and the prevent infection.  
**-Seek** medical assistance immediately.  
 Failure to comply could result in death or serious injury.

W0341A

**⚠ WARNING**

**Escaping refrigerant may cause frostbite!**  
**Always wear protective goggles when handling refrigerant. If you get refrigerant in your eye, immediately flush your eyes with water for 15 minutes. Seek medical assistance immediately.**  
 Failure to comply could result in death or serious injury.

W0339A

When using the air-conditioning, it is essential that all the windows of the operator's compartment are completely closed.

To ensure correct operation and full efficiency of the air-conditioning system, it must be used at least once a week, even for a short time.

**HFC R134A refrigerant**

For technical details, see the decal located on the right side of the cooler.

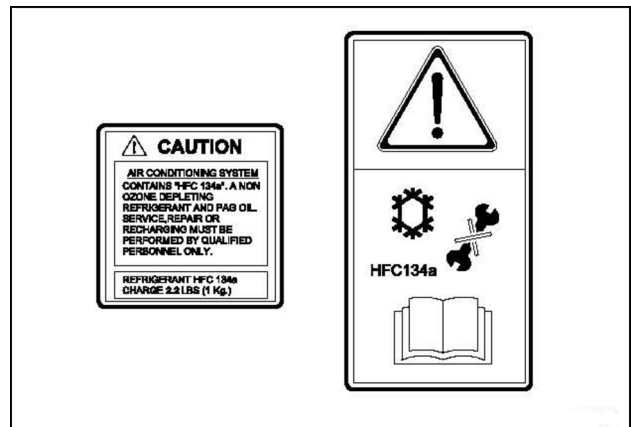

LEEN11T0332AA 8

## Engine speed

It is recommended that you run the engine at full throttle when operating conditions permit and when safe.

**NOTICE:** Do not run the engine at idle speed for long periods. This can cause a low operating temperature. Low operating temperature can cause acids and deposits in the engine oil.

**NOTICE:** Operating the machine at low idle for prolonged periods, increases the frequency of the Selective Catalyst Reduction (SCR) cleaning process (Hydrocarbon management)..

## 4 - OPERATING INSTRUCTIONS

8. (Power shuttle) press the transmission disconnect button **(5)** and then place the gearshift lever **(6)** in first or second gear.

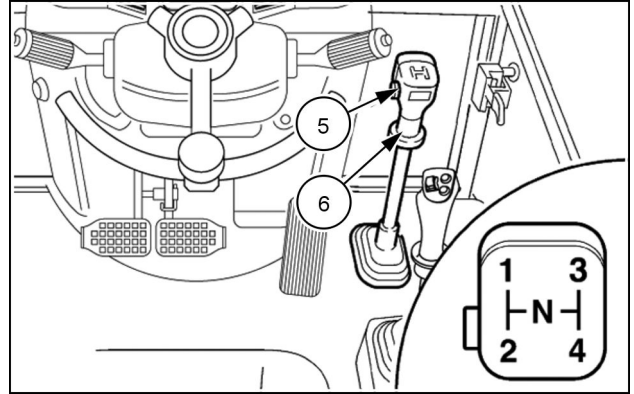

LEEN12T0639AA 4

8. (Powershift) place the gearshift lever **(7)** in first or second gear.
9. Press the brake pedals down and turn the parking brake switch to the OFF position.

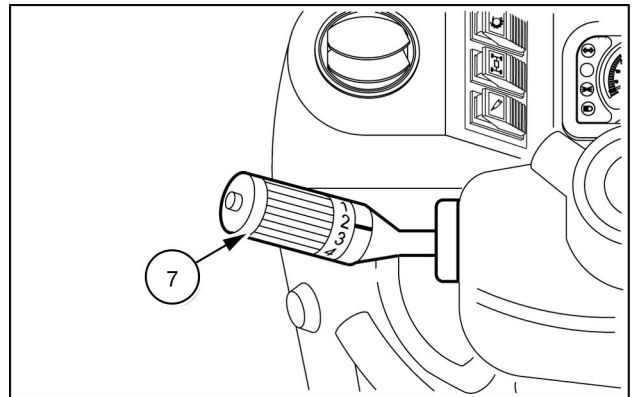

MOL112LBB0212AB 5

10. Place the direction of travel control lever **(4)** in the desired position, forward or reverse travel.
11. Release the brake pedals and control the travel speed by means of the accelerator pedal.

**NOTE:** While traveling, check all gauges and indicator/warning lights frequently.

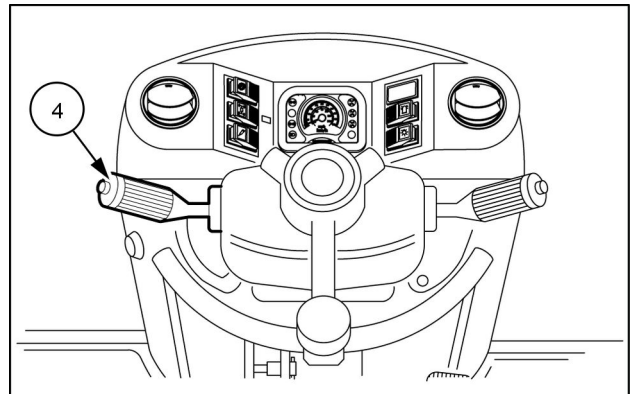

MOL112LBB0213AB 6

## 5 - TRANSPORT OPERATIONS

### ROAD TRANSPORT

#### Precautions for road travel

##### **⚠ WARNING**

**Avoid injury!**

**Before starting the engine, securely fasten the seat belt. The seat belt can help ensure your safety if it is properly used and maintained. Never wear a seat belt loosely or with slack in the belt system. Never wear the belt if it is twisted or pinched between the seat structures.**

**Failure to comply could result in death or serious injury.**

W0142A

##### **⚠ WARNING**

**Collision hazard!**

**Collision of high speed road traffic and slow moving machines can cause death or personal injury. On roads use transport lighting according to local laws. Pull over to let faster traffic pass. Slow down and signal before turning off. Failure to comply could result in death or serious injury.**

W0408A

**NOTICE:** *Before undertaking any road travel, make sure that the backhoe attachment is in road travel position and mechanically immobilized*

### **Tow procedure - engine runs**

1. Engage the parking brake.
2. Block the wheels with wheel chocks.
3. If applicable place the manual transmission lever in the NEUTRAL position.
4. Place the direction control lever in NEUTRAL.
5. Place the Four-Wheel Drive (4WD) switch in the off position, if equipped.
6. Raise all tools and attachments off the ground.
7. Attach a rigid drawbar to the disabled machine.
8. Attach the rigid drawbar to the towing machine. Make sure that the towing machine has enough power and braking ability to move and stop both machines.
9. Remove the wheel chocks.
10. Release the parking brake. If the parking brake will not disengage (for any reason), manually disengage the parking brake. See "Disable parking brake" 7-145.
11. Tow the disabled machine a maximum speed of **2.4 km/h (1.5 mph)**.

### **Tow procedure - engine does not run**

1. Block the wheels with wheel chocks.
2. If applicable, place the manual transmission lever in the NEUTRAL position.
3. Place the direction control lever in NEUTRAL.
4. Attach a rigid drawbar to the disabled machine.
5. Attach the rigid drawbar to the towing machine. Make sure the towing machine has enough power and braking ability to move and stop both machines.
6. Disconnect the rear drive shaft (Two-Wheel Drive machines) or both the front and rear drive shafts (Four-Wheel Drive machines).

**NOTE:** *The machine is equipped with Spring-Applied, Hydraulic-Release (SAHR) parking brake integrated in the transmission. The parking brake remains engaged if the engine is disabled. Manual disengagement of the parking brake is not required for towing with the drive shafts removed.*

7. Remove the wheel chocks.
8. Tow the disabled machine a maximum speed of **2.4 km/h (1.5 mph)**.

## Job layout

### **⚠ WARNING**

**Hazard to bystanders!**

**Always know the location of all workers in your area. Warn them before you start operating the machine. Always keep all unauthorized bystanders clear of the work area.**

**Failure to comply could result in death or serious injury.**

W0206A

### **⚠ WARNING**

**Hazard to bystanders!**

**Material can spill from a loaded bucket. You must manually roll back a loaded bucket before lowering the loader. The self-leveling feature does not automatically roll back the bucket.**

**Failure to comply could result in death or serious injury.**

W0197A

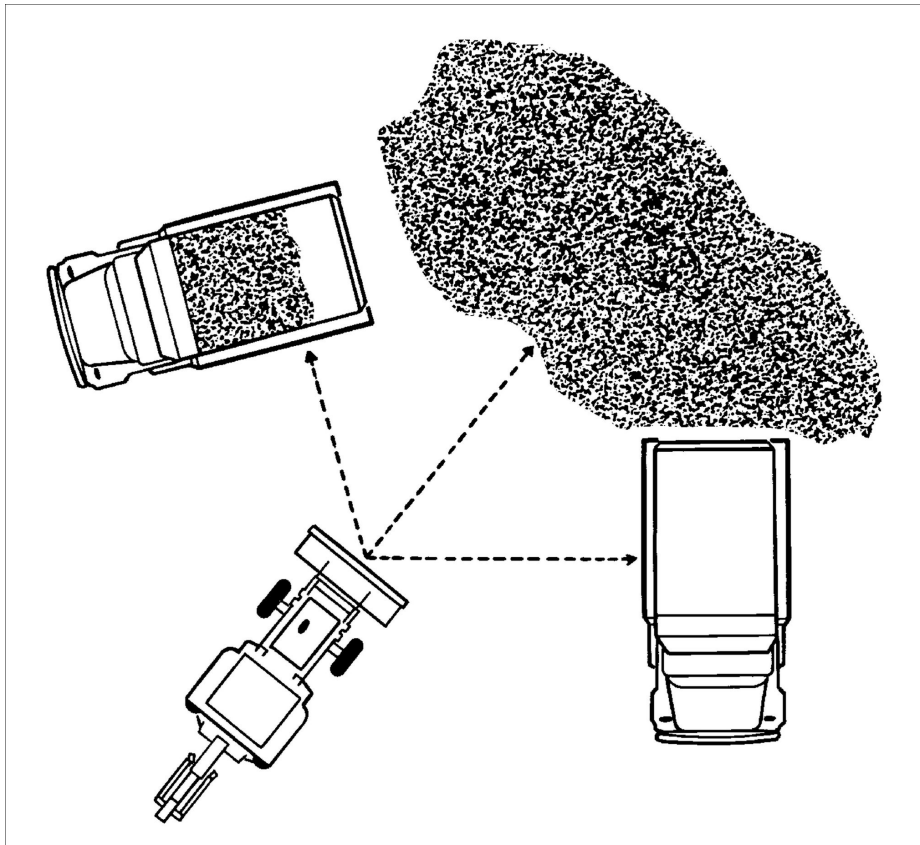

RCPH10TLB005GAF 1

Machine positioning is very important for efficient cycles.

- Set up the work cycle as short as possible.
- Spend a few minutes leveling off the work area, if necessary. Smooth runways for the machine and a level parking area for trucks will speed up the job.

## Loader bucket with quick coupler (B95CTC)

The loader hydraulic coupler allows the operator to change front end attachments without using special tools or additional manpower.

### Installation

1. Make sure the bucket is in a safe area, on a level and firm ground and with the upper pins in place.
2. Tilt the quick coupler forwards and engage the top pins (1) into the upper hooks (2) of the bucket.

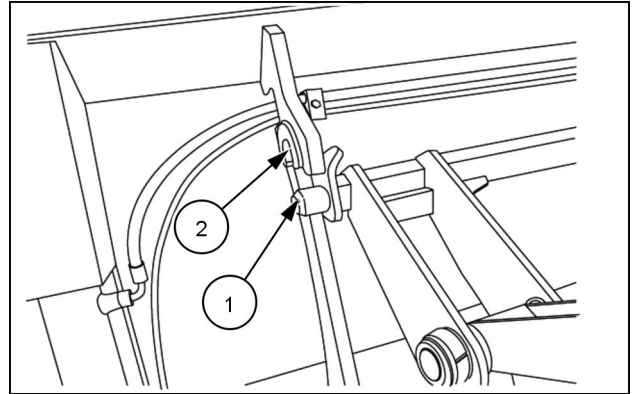

3. Press and hold the quick coupler switch (3) located left of the front instrument panel as indicated in the sign (4).

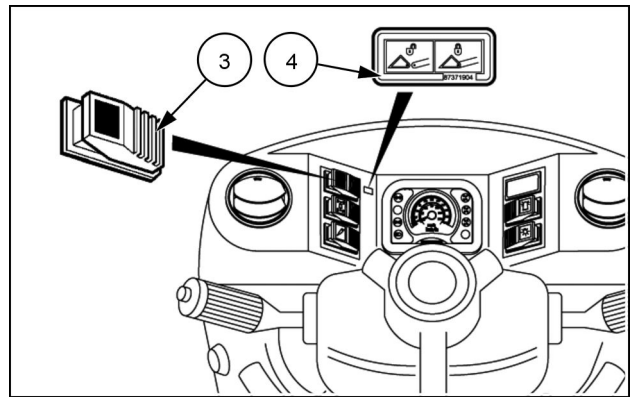

4. This will retract the lock pins (5).

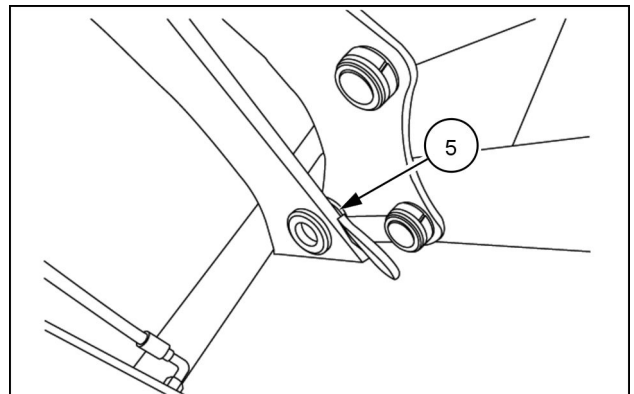

### Unlock the boom (mechanical)

1. Start the machine.
2. Place the direction control lever in NEUTRAL position.
3. If applicable, place gearshift control lever in the NEUTRAL position.
4. Turn the seat into the backhoe operation position.
5. Remove the swing lock pin and place it in the storage position.
6. Lower the stabilizers to the ground so that the rear tires are just off the ground.
7. Move the boom all the way towards you to relieve pressure on the boom lock (2).
8. Press the button on the boom lock control lever (1) and move forward to disengage the boom lock.
9. Lower the boom.
10. If applicable, remove the extendable dipper lock pin (B) and place it in the storage position (A).

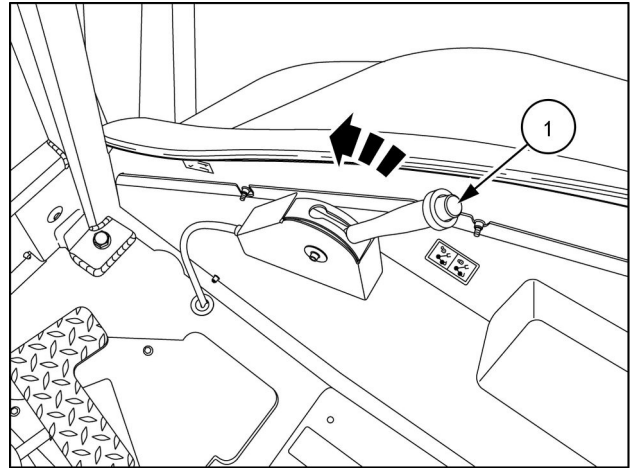

RAIL15TLB0050AA 1

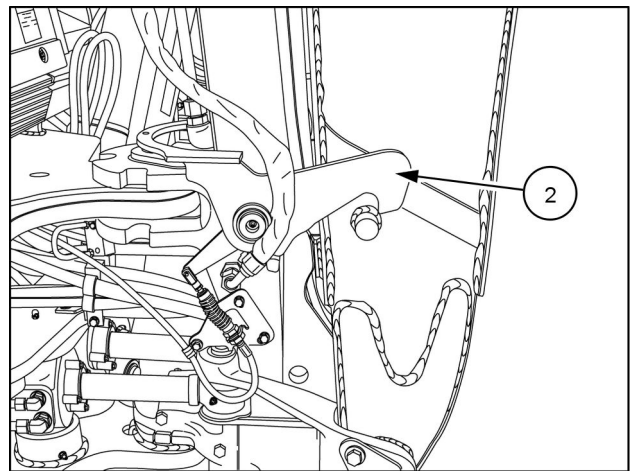

RAIL15TLB0051AA 2

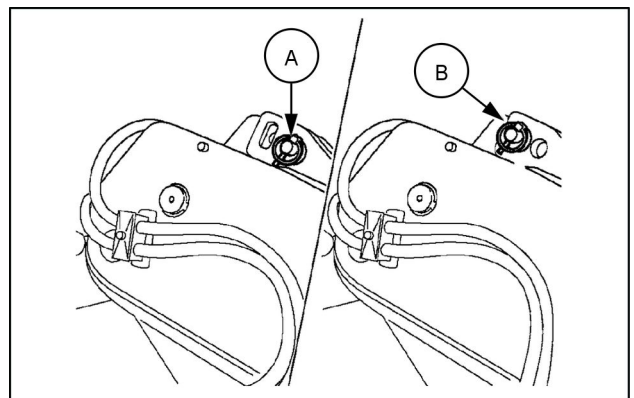

MOL112LBB0244AB 3

CLICK HERE TO **DOWNLOAD** THE COMPLETE MANUAL

- Thank you very much for reading the preview of the manual.
- You can download the complete manual from: [www.heydownloads.com](http://www.heydownloads.com) by clicking the link below



- Please note: If there is no response to CLICKING the link, please download this PDF first and then click on it.

CLICK HERE TO **DOWNLOAD** THE COMPLETE MANUAL

## Backhoe bucket – Remove

1. Move the machine to a level and firm ground.
2. Lower the stabilizers and place the bucket on the ground.
3. Stop the engine and remove the starter switch key.

4. **▲ CAUTION**

**Flying objects!**  
**Wear eye protection. Do not strike steel parts with a steel hammer. Parts may break.**  
**Failure to comply could result in minor or moderate injury.**

C0024A

Remove the lock rings and pins and the rod/bucket link pin (1).

5. Start the engine.
6. Retract the bucket cylinder rod.
7. Operate the attachment controls so that the dipper/bucket pin is not supporting the load of the dipper.
8. Stop the engine and remove the starter switch key.
9. Remove the lock rings and pins and the arm/bucket link pin (2).
10. Start the engine.
11. Operate the attachment controls so as to disconnect the dipper from the bucket.

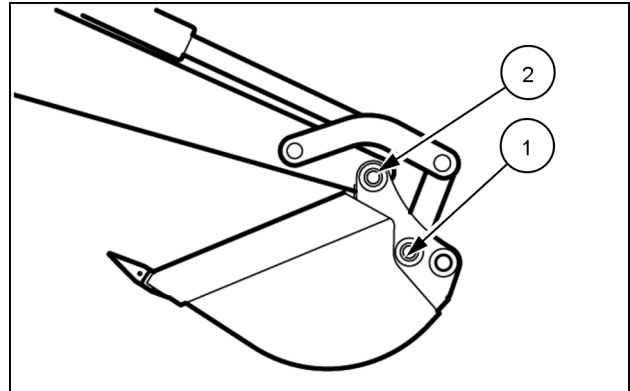

LEEN12T0675AA 1

## Capacities – B110C

### Engine crank case

Specification:	<b>NEW HOLLAND AMBRA UNITEK MASTERGOLD SBL CJ-4 SAE 10W-40( API CJ-4)</b>
Capacity:	
With filter change	<b>8.0 L (8.5 US qt)</b>

### Fuel tank

Specification:	<b>ASTM D975 GRADE No. 2-D S15 (No. 2 diesel)</b>
Capacity:	<b>131.0 L (34.6 US gal)</b>

### Diesel Exhaust Fluid (DEF)/AdBlue® tank

Specification:	<b>DEF/AdBLUE®</b>
Capacity:	<b>13.2 L (3.5 US gal)</b>

### Cooling system

Specification:	<b>NEW HOLLAND AMBRA ACTIFULL™ OT EXTENDED LIFE COOLANT ( 50 % concentrate and 50 % distilled water)</b>
With or without heater	<b>24.0 L (25.4 US qt)</b>

### Hydraulic system

Specification:	<b>NEW HOLLAND AMBRA MULTI G™ HYDRAULIC TRANSMISSION OIL or NEW HOLLAND AMBRA HYDROSYSTEM 46 BIO-S</b>	
Capacity:		
Total system	<b>136.8 L (144.6 US qt)</b>	
Reservoir refill to sight glass line	<b>50.8 L (53.7 US qt)</b>	

### Transmission

Specification:	<b>NEW HOLLAND AMBRA MULTI G™ HYDRAULIC TRANSMISSION OIL</b>	
Capacity:		
Manual (powershuttle)		
	Two wheel drive	Four wheel drive
Total system	<b>18.5 L (19.5 US qt)</b>	<b>20.8 L (22.0 US qt)</b>
Refill (with or without filter change)	<b>11.9 L (12.6 US qt)</b>	<b>14.4 L (15.2 US qt)</b>

#### Powershift

	Four wheel drive
Total system	<b>18.0 L (19.0 US qt)</b>
Refill (with or without filter change)	<b>11.4 L (12.0 US qt)</b>

**NOTE:** The master brake cylinder receives fluid from the transmission.

### Front drive axle - Four-Wheel drive (4WD)

Specification:	<b>TUTELA TRANSAXLE FLUID SAE 80W-140</b>
Capacity:	
Differential	<b>6.5 L (6.9 US qt)</b>
Each planetary hub	<b>0.7 L (0.7 US qt)</b>

## Engine oil viscosity

For machines using Tier 4B (final) engines

	(H)	0W-40 CJ-4 UNITEK to CNH MAT3521 or ACEA E9									
	(H)	0W-40 API CJ-4* or ACEA E6*									
	(H)	5W-30 ACEA E6**									
	(H)	10W-40 CJ-4 UNITEK to CNH MAT3521 or ACEA E9									
	(H)	10W-40 API CJ-4* or ACEA E6*									
	(H)	15W-40 CJ-4 to CNH MAT3522* or ACEA E9									
	(H)	15W-40* API CJ-4* or ACEA E6*									
-40 °C -40 °F	-30 °C -22 °F	-20 °C -4 °F	-10 °C 14 °F	0 °C 32 °F	10 °C 50 °F	20 °C 68 °F	30 °C 86 °F	40 °C 104 °F	50 °C 122 °F		
<p>(H) Engine oil pan or coolant block heater recommended in this range</p> <p>* Requires a <b>50 %</b> reduction in oil change interval</p> <p>**The use of 5W-30 CJ-4 engine oil is not recommended.</p>											

## Hydraulic filter(s)

**NOTICE:** Always replace the hydraulic filter whenever the warning lamp  remains illuminated while the engine is running.

**NOTICE:** Oil quality and cleanliness are of utmost importance for the reliability and life of the hydraulic system. Deviation from the prescribed oil specification may lead to severe damage and void warranty.

Hydraulic oil specification: **NEW HOLLAND AMBRA MULTI G™ HYDRAULIC TRANSMISSION OIL**

1. Prepare the machine for service:
  - A. Park on level ground.
  - B. Lower all attachments to the ground.
  - C. Engage park brake.
  - D. Turn off engine.
  - E. Move each hydraulic control levers in all directions to relieve pressure.

The hydraulic filter is located under the left rear portion of the machine just in front of the rear axle.

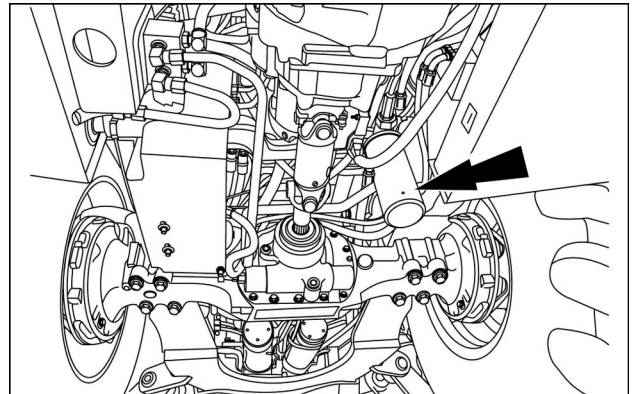

RCPH10TLB042AAF 1

2. Use the special wrench and slowly open the hydraulic reservoir cap to relieve system pressure.

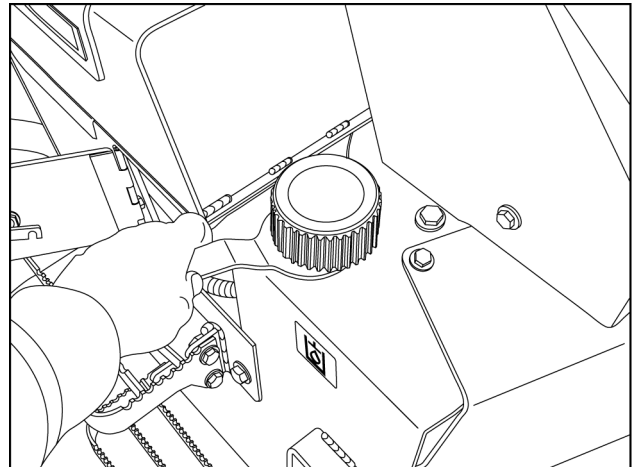

RAIL15TLB0083AA 2

## Windshield washer fluid level — Check

1. Move the machine to a level and firm surface.
2. Make sure the machine is in a safe condition.
3. Stop the engine and remove the starter switch key.
4. To check the level of the windshield wiper/washer fluid, open the reservoir cap (1) check the windshield wiper/washer fluid.
5. If the wiper/washer fluid is not visible, then refill the reservoir.

**NOTICE:** The windshield wiper motor is gravity-fed. Do not remove the rubber tube as damage can be caused if liquid gets into the motor.

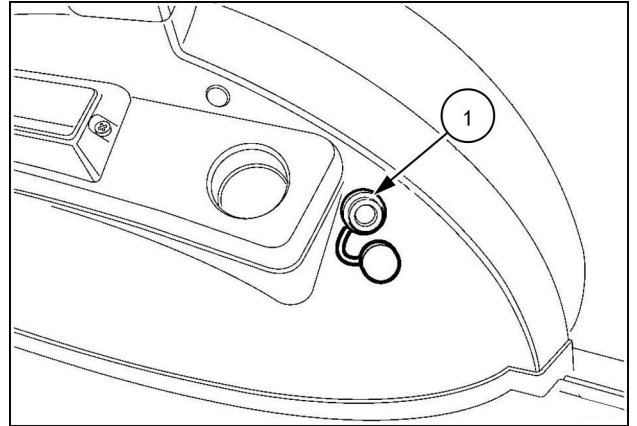

LEEN12T0570AA 1

### Fluid specification and capacity

Use TUTELA PROFESSIONAL SC35 or a windscreen washer fluid approved by NEW HOLLAND CONSTRUCTION.

## Door hinges

1. Lubricate the door hinges. The number of grease fittings (1): 4

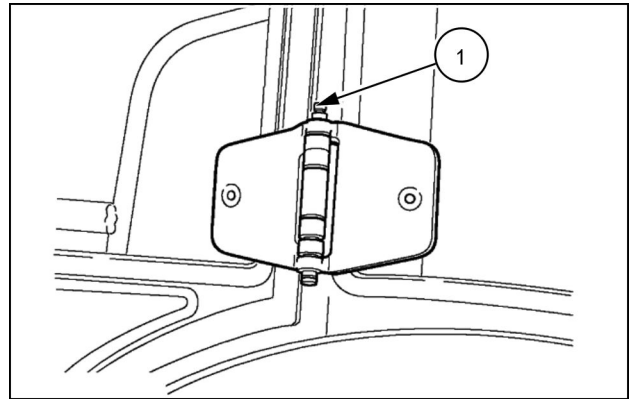

LEEN11T0373AA 1

## Grease specifications

Use **NEW HOLLAND AMBRA GR 75 MD**.

## Front axle trunnion

### Front axle - Greasing

1. Locate the grease fitting (1) at the front of the machine and lubricate the front axle trunnion with **NEW HOLLAND AMBRA GR 75 MD**. Number of grease fittings (1): 1

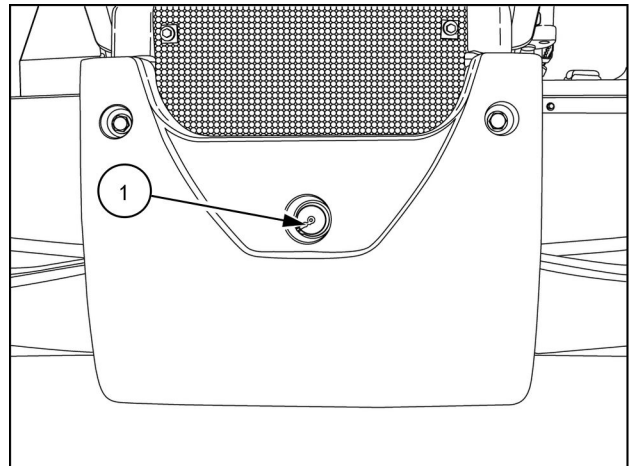

RAIL15TLB0045AA 1

## Grease specifications

Use **NEW HOLLAND AMBRA GR 75 MD**

## Engine cooling system — Check

### Cooling system lines - Check

1. Move the machine to a level and firm surface.
2. Raise the loader attachment and install the safety support strut.
3. Place the backhoe attachment in the road travel position.
4. Place the direction-of-travel lever and gearshift lever in the neutral position.
5. Engage the parking brake.
6. Stop the engine and remove the starter switch key.
7. Release any possible residual hydraulic pressure by moving the control levers in all directions.
8. Unlock and raise the engine hood.
9. Check all of the engine cooling system lines for possible leaks.
10. Check the tightness of the collars, fittings, hoses and pipes of the engine cooling system.
11. Repair any leaks or contact your local authorized dealer for machine service.
12. Lower and lock the engine hood.
13. Remove the safety support strut and lower the loader attachment.

## Radiator and condenser - cleaning

1. Move the machine to a level and firm surface.
2. Raise the loader attachment and install the safety support strut.
3. Place the backhoe attachment in the road travel position.
4. Place the direction-of-travel lever and gearshift lever in the neutral position.
5. Engage the parking brake.
6. Stop the engine and remove the starter switch key.
7. Remove the front grille.
8. Unscrew and remove the fasteners from the condenser (1).
9. Lower the condenser (1).
10. If necessary, tilt the dryer to the side (2).
11. Disconnect the two pipes complete with the rubber sleeves from the top of the aftercooler (3).
12. Plug the holes on the after cooler and the pipes of the aftercooler system.
13. Remove the fasteners and remove the aftercooler (3).

### 14. **⚠ CAUTION**

#### **Flying debris!**

**Compressed air can propel dirt, rust, etc. into the air. Wear eye and face protection when using compressed air.**

**Failure to comply could result in minor or moderate injury.**

C0049A

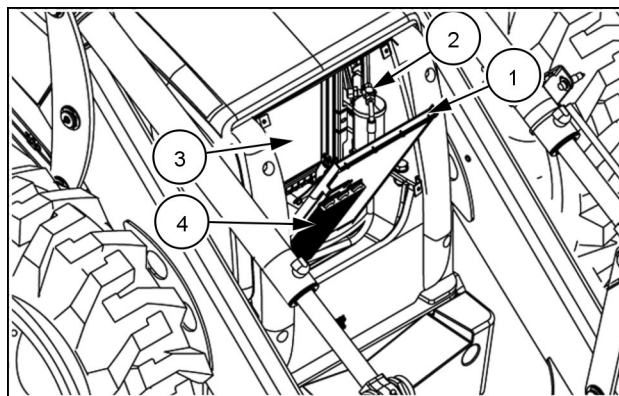

LEEN11T0382AA 1

Clean the condenser (1), the aftercooler (3), the fuel cooler (4) and the hydraulic oil cooler behind the aftercooler using:

- Compressed air with a pressure lower than **7 bar (102 psi)** to remove dry dust;
  - Water jet to remove mud;
  - A detergent-based solution, preferably applied with a low-pressure cleaner, to remove oily dust.
15. Make sure all dirt and debris have been removed from between the condenser and the coolers. This action maintains efficient heat transfer for the condenser.
  16. Reassemble the aftercooler (3) and related pipes, reposition the dryer (2) and reassemble the condenser (1) together with the fuel cooler (4).
  17. Reinstall the front grille.
  18. Remove the safety support strut and lower the loader attachment.

**⚠ WARNING**

**Roll-over hazard!**

After an accident, fire, tip over, or roll over, a qualified technician **MUST** replace the Roll-Over Protective Structure (ROPS) before returning the machine to the field or job site operation.

Failure to comply could result in death or serious injury.

W0134A

**⚠ WARNING**

**Misuse hazard!**

Your machine is equipped with an operator protective structure. **DO NOT** weld, drill holes, attempt to straighten, or repair the protective structure. Modification in any way can reduce the structural integrity of the structure.

Failure to comply could result in death or serious injury.

W0001B

**NOTE:** For your safety, the machine cab has been designed to prevent flame propagation and to limit combustions in case of fire. The machine cab complies to **ISO 3795** norms.

The Loader has a ROPS/FOPS sign showing the certification of the ROPS/FOPS, gross weight, approval, regulation, and model number of the machine.

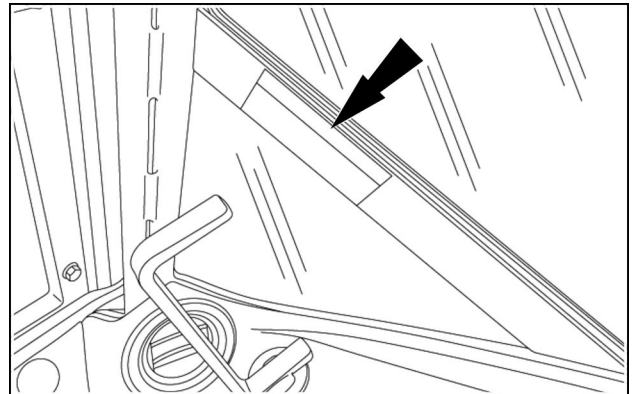

LEEN11T0376AA 1

9. Turn the screen filter counter-clockwise and remove.

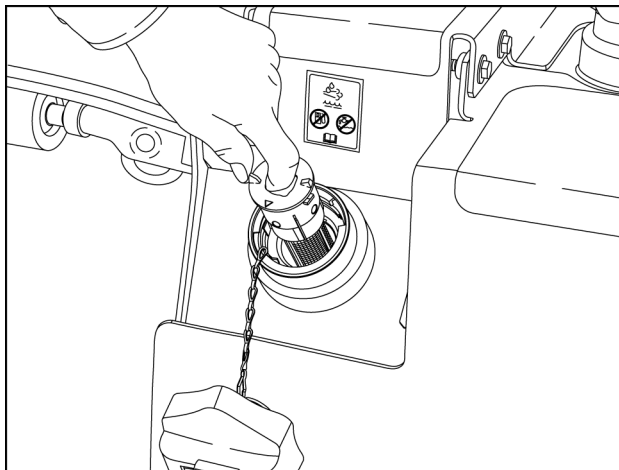

RAIL15TLB0063AA 3

10. Rinse the screen filter with water.
11. Air or blow dry the screen filter.

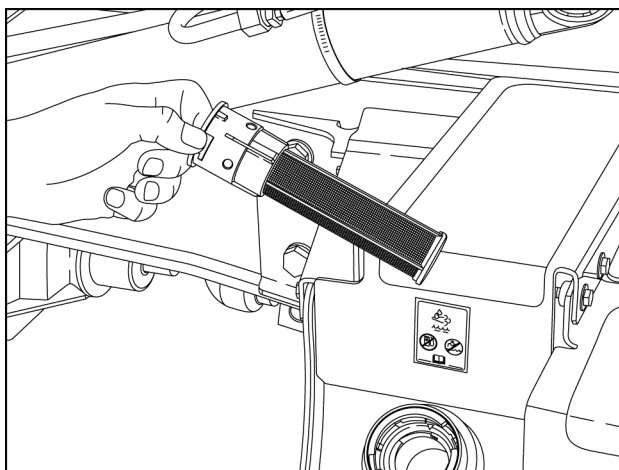

RAIL15TLB0064AA 4

12. Fully Insert the screen filter and turn it clockwise.
13. Secure the cap on the tank.

17. Drive the machine for a few minutes in first and second gear, and then stop the machine with engine running, and the direction-of-travel lever and the transmission gearshift in the neutral position.
18. Engage the parking brake.
19. Check the oil level again by means of the dipstick and, if necessary, add more oil.
20. Lower and lock the engine hood.
21. Remove the safety support strut and lower the loader attachment.

### **Oil specification and capacities**

Use **NEW HOLLAND AMBRA MULTI G™ HYDRAULIC TRANSMISSION OIL**.

Capacities: 2WD Total System **18.5 L (19.5 US qt)**, Refill with or without filter change **11.9 L (12.6 US qt)**.

Capacities: 4WD Total System **20.8 L (22.0 US qt)**, Refill with or without filter change **14.4 L (15.2 US qt)**.

## Machine inspection and cleaning

### Inspection

Externally check the machine and its working attachments, checking for possible breaks or damage of the components or the structure.

If you find any problems, contact an authorized workshop to have the necessary repairs carried out.

Replace the damaged or excessively worn parts with original spare parts.

Check the conditions of the hydraulic lines and make sure there are no leaks. In this case, immediately eliminate them.

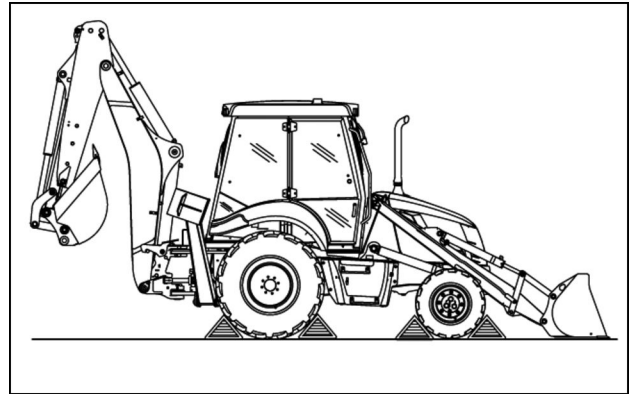

LEEN12T0640AA 1

### Cleaning

A correctly performed periodical maintenance helps preserving the value of the machine and the warranty rights in case of possible corrosion damage.

The necessary products for machine care can be purchased from the Service Department or Spare Part Service. Carefully observe all instructions on the packaging.

**NOTICE:** *In respect of the environment, the machine should be washed only at specially provided washing stations equipped with oil and grease separators, if possible. Washing machines outside these stations may be even forbidden in some regions or countries.*

**NOTICE:** *When washing the machine, do not direct the water jet onto electrical or electronic components or assemblies. Water sprays or jets may cause malfunctions or the failure of the entire electrical and electronic system.*

16. Connect the three connections back to the supply module. you will hear them snap in place.

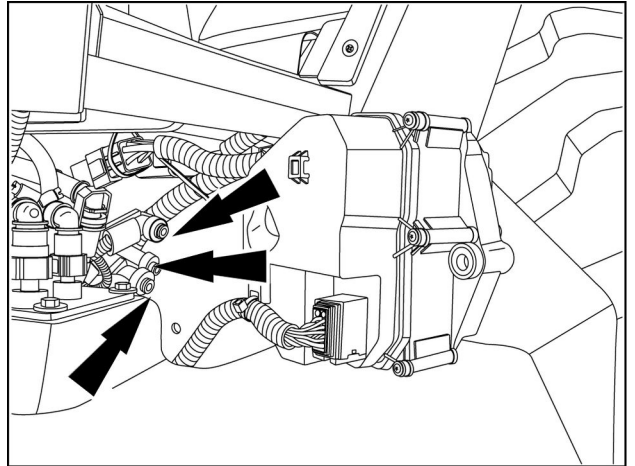

RAIL14TLB0968BA 17

17. Install the bracket and secure the supply module in place.

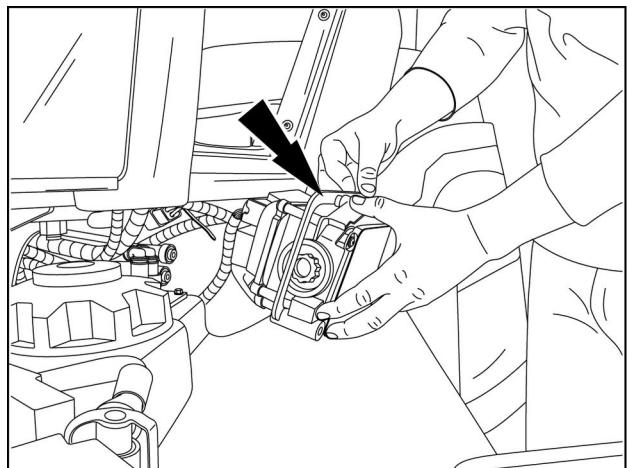

RAIL14TLB0970BA 18

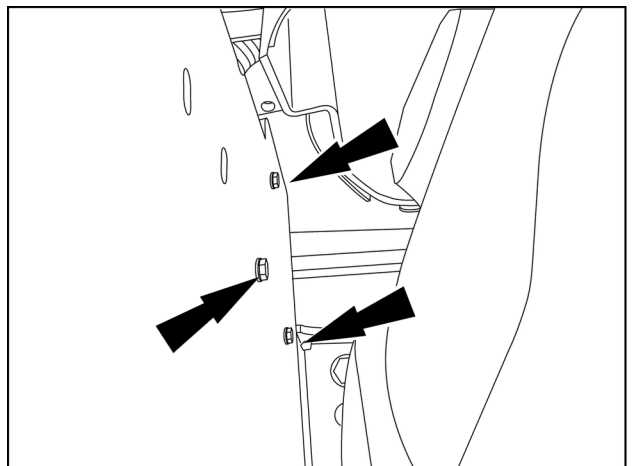

RAIL14TLB0964BA 19

## Hydraulic system - Release pressure

1. Park the machine on firm level ground.
2. Put all transmission controls in the Neutral position.
3. Engage the parking brake.
4. Lower the bucket to the ground but do not apply down pressure; or raise the loader arm and engage the loader arm safety support.
5. Rotate the operator seat into the backhoe operation position.
6. Place the backhoe in the stowed position with swing lock pin in the lock position. If applicable, insert the Extendahoe lock pin. You may choose to rest the backhoe attachment on the ground.
7. Shut off the engine.
8. Turn the key switch to the ON position but DO NOT start the engine.
9. Press the emblem end of the backhoe and stabilizer control switch to activate all backhoe controls.

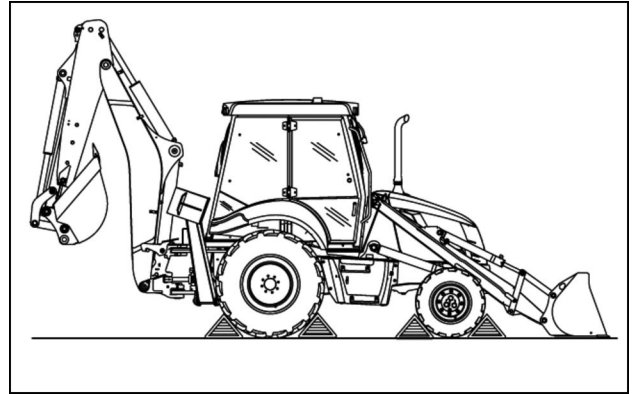

LEEN12T0640AA 1

**NOTE:** When turning the backhoe and stabilizer control switch to the ON position, wait approximately half a second before activating the stabilizers, extendahoe (if equipped) or bi-directional auxiliary hydraulics (if equipped). If an operator attempts to operate the functions before the delay passes, the functions will not operate. Cycle the power switch and wait for the delay to pass.

10. If equipped with combo auxiliaries, enable the bidirectional switch on the right-hand side panel.
11. Cycle the bi-directional proportional control buttons on the left-hand pilot control joystick.
12. Move each pilot backhoe control joystick in one complete circle, stopping in the neutral (center) position.

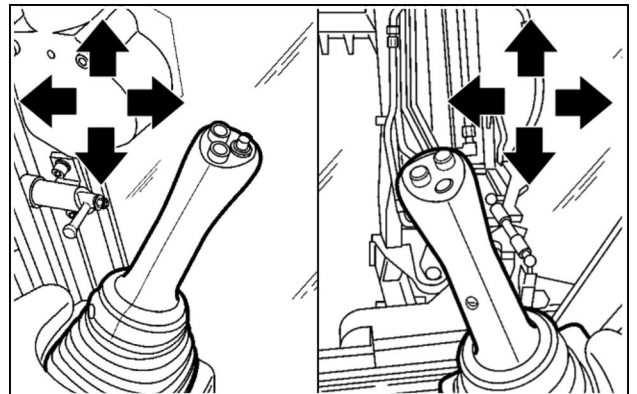

LEEN12T0487AA 2

13. Deactivate the backhoe and stabilizer control switch.
14. Rotate the operator seat into the driving position.

## Fuses and relays – Power shuttle

**NOTICE:** NEVER replace a fuse with a fuse of a different rating.

### Engine Control Unit (ECU) – cab fuse and relay module

Remove the lower right-hand front-side cover panel.

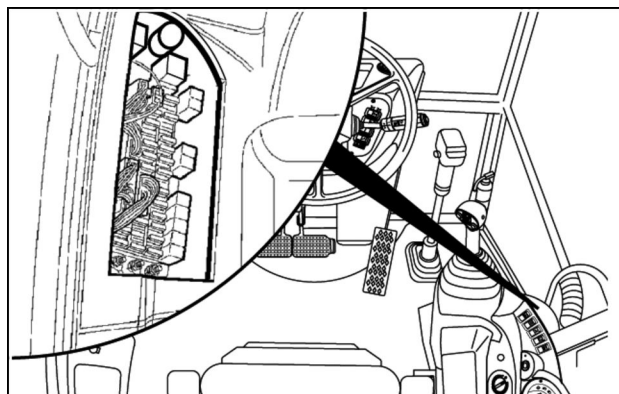

LEEN12T0495AA 1

### Fuses

Fuse No.	Rating	Function
F1A	–	not used
F1B	7.5 A	Fuel shut off, +15 antitheft, key switch +15 ECU, reset parking brake fuse
F1C	10 A	Pedal break stop switch fuse
F2A	15 A	Instrument side panel, switches lamps, seat
F2B	–	not used
F2C	15 A	Pilot control
F3A	3 A	Rear right/front left side light, instrument illumination
F3B	3 A	Rear left/front right side lights, number plate light
F3C	10 A	Glide ride control , working light , hydraulic speed control , 4xr1a bg
F4A	–	not used
F4B	10 A	Hand tool button, grab level valve and sensor, clutch shut off button and diff block button fuse
F4C	10 A	Rear excavator lock, rear transport lock ,working light fuse
F5A	15 A	Front internal working lights
F5B	15 A	Low beam fuse
F5C	15 A	Main beam fuse
F6A	15 A	Rotating beacon
F6B	7.5 A	(+15) hazard warning light power supply
F6C	7.5 A	Hand tool, 4WD fuse
F7A	10 A	(+30) power supply for hazard warning lights, horn
F7B	–	not used
F7C	–	not used
F8A	15 A	Outer front work lights
F8B	15 A	Outer front work lights
F8C	15 A	Inner rear work lights

### Relays

Relay reference	Designation
K1	Forward-reverse speed switch relay
K3	Starting relay
K4	Grab level solenoid valve relay
K5	not used
K6	Inner front work light relay
K7	Inner rear work light relay

## Loader bucket - Self-leveling adjustment

1. The self-leveling linkage mounted on the right hand loader arm and frame automatically controls the angle of the loader bucket during the raising cycle of the lift arms to maintain a constant bucket level. There is no self-leveling during the lowering cycle.
2. Self-leveling begins when the tube (2) on the loader arm contacts the bell crank (1) and lifts the vertical linkage rod (3).
3. The tie rod then moves the bucket spool to the dump position to level the bucket.

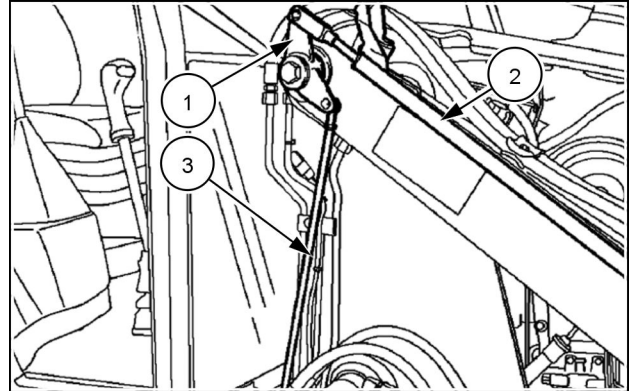

LEEN12T0696AA 1

## Automatic self-leveling control and adjustment

1. Lower the loader attachment to the ground.
2. Disconnect the vertical tie rod (3) at the lower bell crank.
3. Raise the loader attachment so that the lower bucket pin is **800 mm (31.5 in)** above the ground, and fully turn over the bucket to the rear.
4. Rotate the bell crank (1) till it touches the tube (2) on the loader arm. Make sure the lower bell crank arm is directing upwards.
5. Adjust the length of the vertical rod (3) so that when reconnected, the end of the loader arm tube remains in contact with the bell crank.
6. Securely tighten the lock nuts on a vertical tie rod.

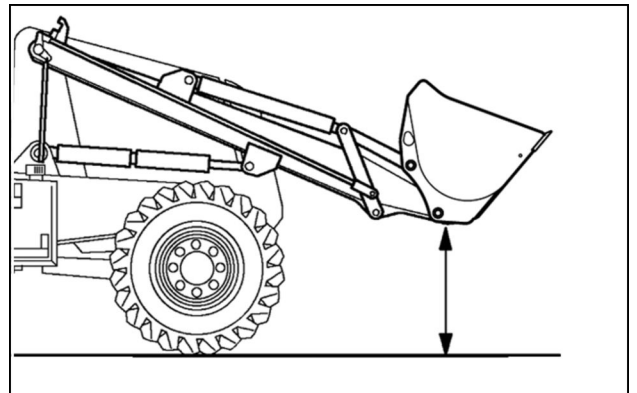

LEEN12T0697AA 2

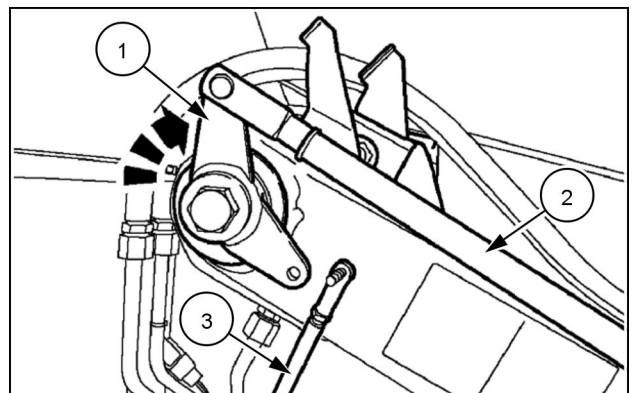

LEEN12T0698AA 3

## Starter motor - Troubleshooting

<b>Problem</b>	<b>Possible Cause</b>	<b>Correction</b>
<b>The starter motor does not run.</b>	Too low specific density and battery level.	Inspect the battery.
	Poor ignition switch circuit connection or contact.	Replace the wiring harness and the ignition switch or starter motor runs too slowly.
	Malfunction of the coil or of the magnetic switch pull-in cylinder.	Replace the magnetic switch.
<b>The starter motor running cannot crank the engine.</b>	The pinion gear does not engage with the ring gear.	Repair or replace the clutch and the control lever.
	Sliding clutch.	Replace the clutch.
<b>Anomalous noise.</b>	Anomalous bushing wear.	Replace starter.
	Wear on pinion gear or ring gear tooth tips.	For ring gear damage contact dealer.
	Poor pinion gear sliding.	Replace starter.
<b>The pinion gear springs.</b>	Poor ignition switch return.	Replace the ignition switch.
<b>Field coil loss. Magnetic switch coil burnt, etc.</b>	Pinion gear disengagement fault caused by a coil short circuit in the magnetic switch.	Replace the magnetic switch.

## Loader attachment - Troubleshooting

<b>Problem</b>	<b>Possible Cause</b>	<b>Correction</b>
<b>The lifting circuit fails to operate, is slow or loses power.</b>	Valve spool leaking.	Inspect the spool and check it for wear or scratches.
	Cylinder seals leaking or cylinder barrel damaged.	Inspect and reseal the cylinder.
<b>The bucket fails to operate, is slow or loses power.</b>	The relief valves are stuck open, set to a too low value or there is a leak in the seat.	Check the bucket circuit relief valve.
	Valve spool leaking.	Inspect the spool and check it for wear or scratches.
	Cylinder seals leaking or cylinder barrel damaged.	Inspect and reseal the cylinder.
<b>Cylinder leak (spools in neutral).</b>	Damaged cylinder barrel.	Inspect and reseal the cylinder.
	Internal valve leak.	Inspect the spool and check it for wear or scratches.
<b>Hesitation in the raising movement of the loader attachment or of the bucket cylinders when the control is initially actuated.</b>	Load check valve between control valve sections damaged.	Disassemble and inspect.

## 9 - SPECIFICATIONS

### Capacities - B95C and B95C TC

#### Engine crank case

Specification: **NEW HOLLAND AMBRA UNITEK MASTERGOLD SBL CJ-4 SAE 10W-40( API CJ-4)**

Capacity:  
With filter change **8.0 L (8.5 US qt)**

#### Fuel tank

Specification: **ASTM D975 GRADE No. 2-D S15 (No. 2 diesel)**

Capacity: **131.0 L (34.6 US gal)**

#### Diesel Exhaust Fluid (DEF)/AdBlue® tank

Specification: **DEF/AdBLUE®**

Capacity: **13.2 L (3.5 US gal)**

#### Cooling system

Specification: **NEW HOLLAND AMBRA ACTIFULL™ OT EXTENDED LIFE COOLANT ( 50 % concentrate and 50 % distilled water)**

With or without heater **24.0 L (25.4 US qt)**

#### Hydraulic system

Specification: **NEW HOLLAND AMBRA MULTI G™ HYDRAULIC TRANSMISSION OIL or NEW HOLLAND AMBRA HYDROSYSTEM 46 BIO-S**

Capacity:  
Total system **110.8 L (117.1 US qt)**

Reservoir refill to sight glass line **50.8 L (53.7 US qt)**

#### Transmission

Specification: **NEW HOLLAND AMBRA MULTI G™ HYDRAULIC TRANSMISSION OIL**

Capacity: Manual (powershuttle)	Two wheel drive	Four wheel drive
Total system	<b>18.5 L (19.5 US qt)</b>	<b>20.8 L (22.0 US qt)</b>
Refill (with or without filter change)	<b>11.9 L (12.6 US qt)</b>	<b>14.4 L (15.2 US qt)</b>

Powershift	Four wheel drive (only)
Total system	<b>18.0 L (19.0 US qt)</b>
Refill (with or without filter change)	<b>11.4 L (12.0 US qt)</b>

**NOTE:** The master brake cylinder receives fluid from the transmission.

#### Front drive axle - Four-Wheel drive (4WD)

Specification: **TUTELA TRANSAXLE FLUID SAE 80W-140**

Capacity:  
Differential **6.5 L (6.9 US qt)**  
Each planetary hub **0.7 L (0.7 US qt)**

## Noise and vibration levels

### Noise level

Internal noise level (LpA)	<b>77 dB</b>
External noise level (LwA) (B95C - B95CTC - B95BLR)	<b>102 dB</b>
External noise level (LwA) (B110C)	<b>103 dB</b>

### Vibration level inside the cab

Upper limbs	level lower than <b>2.5 m/s<sup>2</sup> (8.20 ft/s<sup>2</sup>)</b>
Abdomen	level lower than <b>0.5 m/s<sup>2</sup> (1.64 ft/s<sup>2</sup>)</b>

## Backhoe attachment performance

### B95C and B110C (with short standard dipper)

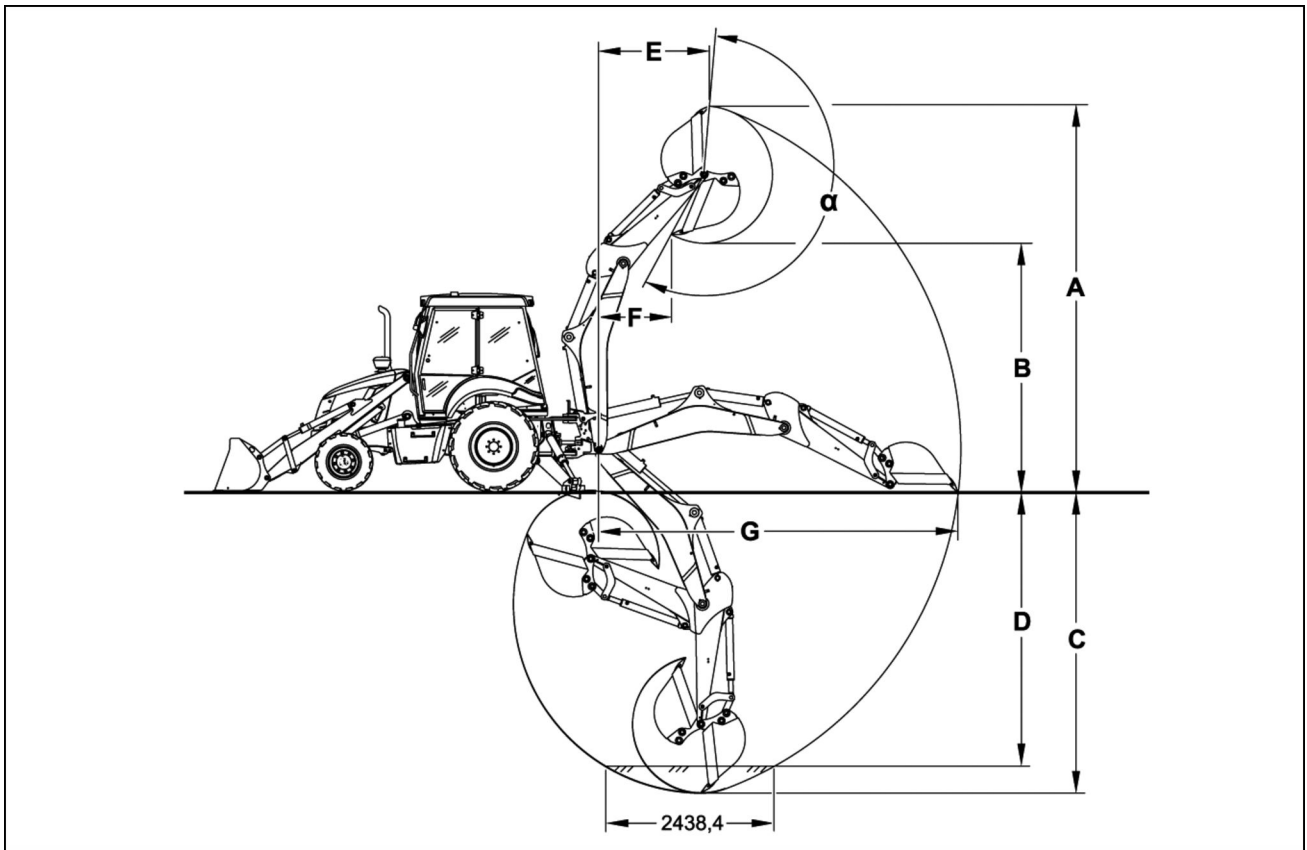

LEEN12T0745FA\_1 1

- A. Maximum digging height
- B. Maximum height at full load
- C. Maximum digging depth
- D. Digging depth [L = **2438.4 mm (96.00 in)**]
- E. Digging reach at maximum height
- F. Maximum reach when loaded
- G. Maximum digging reach with lowered bucket
- α. Bucket digging angle

Front tires	11L-16F3
Rear tires	17.5L-24
A	<b>5441 mm (214.2 in)</b>
B	<b>3585 mm (141.1 in)</b>
C	<b>4426 mm (174.3 in)</b>
D	<b>4034 mm (158.8 in)</b>
E	<b>1556 mm (61.3 in)</b>
F	<b>1160 mm (45.7 in)</b>
G	<b>5186 mm (204.2 in)</b>
α	204.6°

4. Rotate the bucket out and lower to the ground.
5. Rotate the quick coupler out of the bucket.
6. Pick up the next bucket and raise the boom.

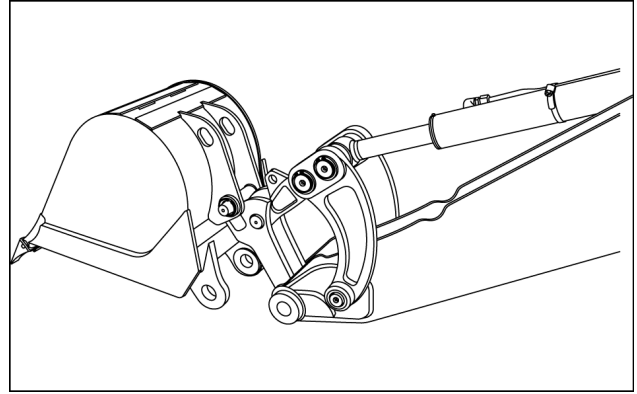

RCPH10TLB397AAF 3

7. Suspend the bucket off the ground, retract the bucket cylinder until the bucket starts to rotate out.
8. Install the bucket pin, the steel washer, and the snap ring.

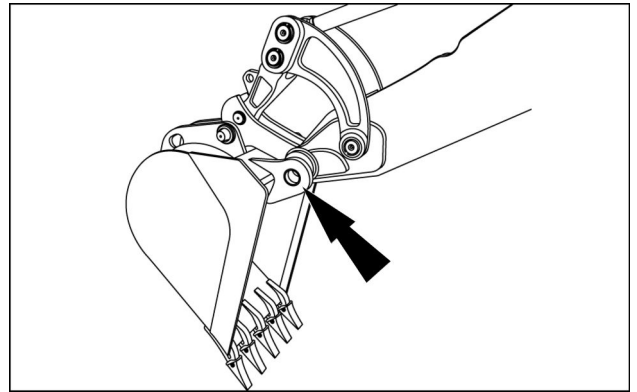

RCPH10TLB398AAF 4

CLICK HERE TO **DOWNLOAD** THE COMPLETE MANUAL

- Thank you very much for reading the preview of the manual.
- You can download the complete manual from: [www.heydownloads.com](http://www.heydownloads.com) by clicking the link below



- Please note: If there is no response to CLICKING the link, please download this PDF first and then click on it.

CLICK HERE TO **DOWNLOAD** THE COMPLETE MANUAL