

Operator's Manual

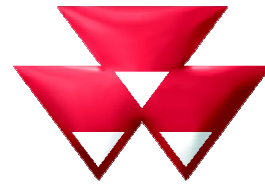

MASSEY FERGUSON

MF 7700 S - Maintenance

MF 7720 S

MF 7722 S

MF 7724 S

MF 7726 S



Dyna-6

Beauvais

**AGCO S.A.S. - 41 avenue Blaise Pascal - 60000
Beauvais - France - RC B562 104 539**

© AGCO 2017

Original Operator's Manual

November 2017

ACT0032400

EAME

English

CLICK HERE TO **DOWNLOAD** THE COMPLETE MANUAL

- Thank you very much for reading the preview of the manual.
- You can download the complete manual from: www.heydownloads.com by clicking the link below





- Please note: If there is no response to CLICKING the link, please download this PDF first and then click on it.

CLICK HERE TO **DOWNLOAD** THE COMPLETE MANUAL

1. Safety instructions and safety points - Warranty

1.1 Introduction	13
1.1.1 Introduction - Safety instructions	13
1.2 Safety — Symbols and terms	15
1.2.1 Safety — Symbols and terms	15
1.3 Safety decals and instructions	16
1.3.1 Checking and replacing the safety decals and instructions	16
1.3.2 Presentation and location of the safety decals and instructions	17
1.4 General safety instructions	22
1.4.1 Awareness of the safety instructions and symbols	22
1.4.2 Operator familiarity in the use of the tractor	22
1.4.3 Filling the fuel tank	23
1.4.4 Mounting and dismounting the operator's seat	23
1.4.5 Risk of burns	24
1.4.6 Prevention of accidents caused by lightning	24
1.4.7 Mandatory procedure before dismounting the tractor	24
1.5 Special instructions	26
1.5.1 Specific recommendations for agricultural and forestry tractors	26
1.6 Special safety instructions for preparing the tractor for use	28
1.6.1 Protective clothing	28
1.6.2 Activated carbon filter information	28
1.6.3 Safety devices and items	31
1.6.4 Checking the tractor	31
1.7 Specific safety instructions for starting the tractor	33
1.7.1 Protection of persons other than the operator	33
1.7.2 Start up safely	33
1.7.3 Starting the tractor with jump start cables	34
1.7.4 Checks to be carried out after start-up	35
1.8 Specific safety instructions for using the tractor	36
1.8.1 General instructions	36
1.8.2 Protection of persons other than the operator	37
1.8.3 Overturning	37
1.8.4 Tractor towing	40
1.8.5 Regulatory data on maximum permitted trailed weights	40
1.8.5.1 Drawbars and towing equipment	42
1.8.6 Road use	46
1.8.7 Instructions and Legislation for the Towing of Implements	47
1.8.8 Power take-off	49
1.8.9 Implements	50
1.8.10 Front-end loader	52
1.9 Specific safety instructions for servicing the tractor	54
1.9.1 Pollution warning to observe when servicing the tractor	54
1.9.2 General instructions	54
1.9.3 Handling instructions	55
1.9.4 Special instructions for cleaning the tractor	57
1.10 Protective structures	61
1.10.1 Protective structures - Use and accreditation	61
1.10.2 Cab	61

	<ul style="list-style-type: none"> • 4354351M1(X) • WARNING: Risk of fire <p>Read the safety instructions in the Operator's Manual.</p>
	<ul style="list-style-type: none"> • 4296944M1(Y) • WARNING: Entanglement hazard in belt drives <p>Keep hands clear of rotating parts and belts while engine is running.</p> <p>Switch off the ignition and remove the key before working on the tractor.</p>
	<ul style="list-style-type: none"> • 4296971M1(Z) • WARNING: Shearing hazard – engine fan. <p>Keep your hands away from the fan and the belts when the engine is running.</p> <p>Shut off engine and remove key before performing maintenance or repair work.</p>

1.6.3 Safety devices and items

Ensure that all safety devices and items are fitted as required and are in good condition.



WARNING:

The location of all these safety devices and items must be known and their use mastered. Never take off, remove or disconnect any of them.

Standard safety devices and items according to country regulations

- ROPS (Roll Over Protective Structure)
- Seat belt
- Power take-off guard
- SMV warning triangle
- Signaling lights
- Safety signs
- Fire extinguisher
- First aid kit



WARNING:

Also make sure you know the emergency numbers.



Fig. 6

Additional devices and items

Depending on the work to be carried out, other safety devices and items may be required; for example, guards or additional lights and signs.

1.6.4 Checking the tractor

Check the tractor and ensure that all systems are in good operational condition before beginning the working day. Pay particular attention to the points mentioned below.

- Check for loose, broken, missing or damaged parts. Ensure that everything has been properly repaired.
- Check that the seat belt is in good condition. If it is not, replace it.
- Check that implements are correctly installed.
- Check that the PTO output speed is in keeping with the implement PTO input speed.
- Ensure that all PTO shaft locking devices are engaged.
- Ensure that the tractor PTO guard and the shaft guards are in place and operating correctly.
- Check to ensure that the tractor is correctly balanced.



WARNING:

An unbalanced tractor could overturn and cause serious injury or death. Ensure that front frame counterweights, wheel weights and wheel ballasts are used as recommended by the manufacturer. Do not add extra counterweights to compensate for an overloaded tractor; the load must be reduced instead.

- Check the condition and pressure of tires (absence of cuts and bulges). Replace worn or damaged tires.
- Check the correct operation of the brake pedals and the parking brake. Adjust if necessary.
- Check the hydraulic system for the tractor and the implement as well as the tractor fuel system: Correct tightening of all the unions; no damage to the lines, pipes and hoses; hydraulic systems do not cross one another.

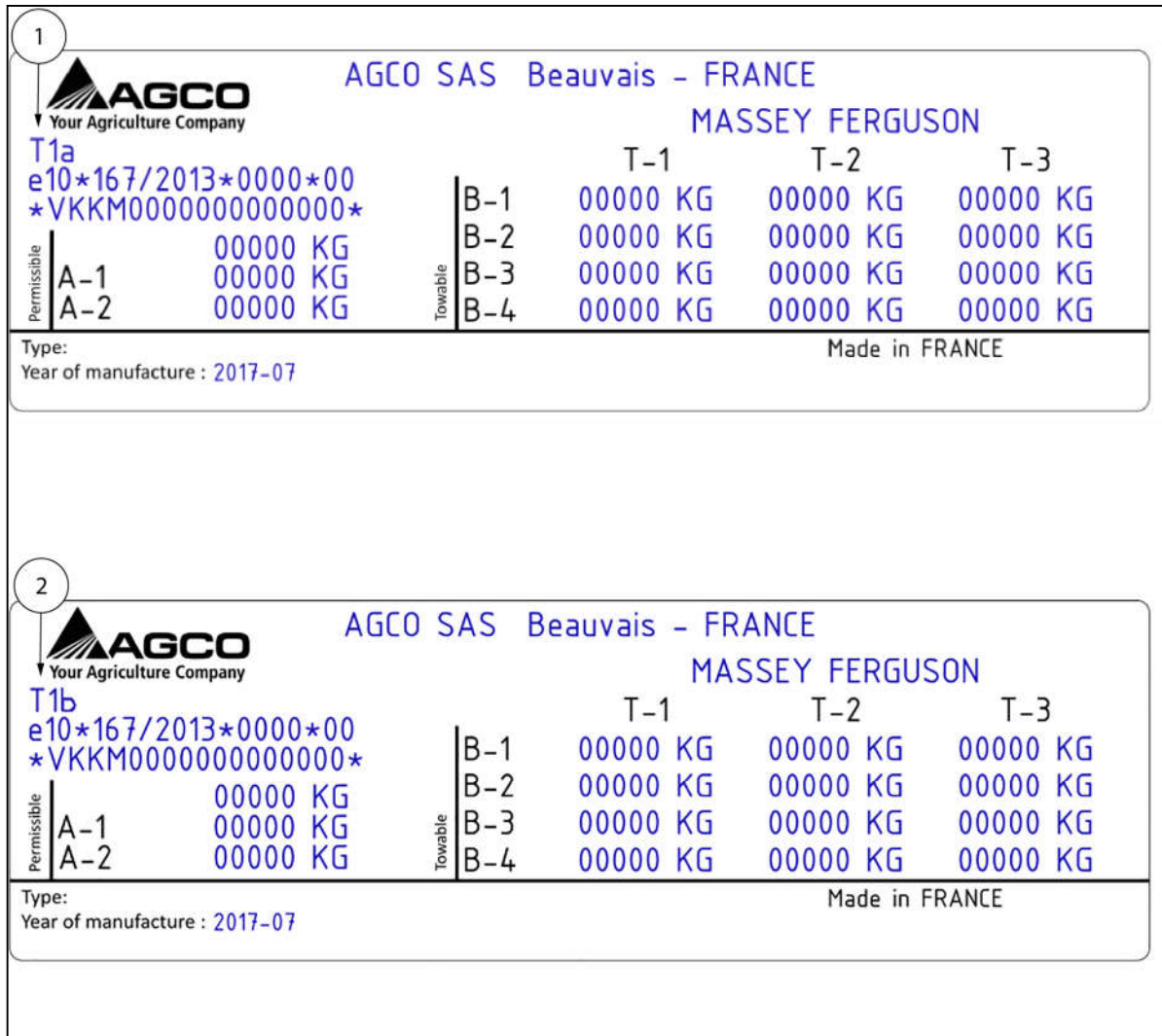

Fig. 14

There are two different types of plate:

- Type T1a manufacturer plates (1), these are for tractors which can travel at a speed of less than or equal to 40 km/h
- Type T1b manufacturer plates (2), these are for tractors which can travel at speeds greater than 40 km/h

The plates are divided into two main categories:

- On the left, maximum technically permissible weights per axle:
 - A-1 relates to the front axle
 - A-2 relates to the rear axle

- All trailed implements and trailers should be connected to the tractor by a safety chain (1) .

Should a trailed implement accidentally become separated from the drawbar during transport, this safety chain will help to retain the trailed implement. Using the appropriate adapter parts, attach the chain to the tractor's drawbar anchor or any other specified anchor point. Leave only enough slack in the chain to allow for maneuvering.

The safety chain must have a strength equal or greater than the weight of the trailed implement: Contact your Massey Ferguson dealer to obtain a suitable chain.

- Only tow using the drawbar. Attaching the trailed implement to another location could cause the tractor to overturn.

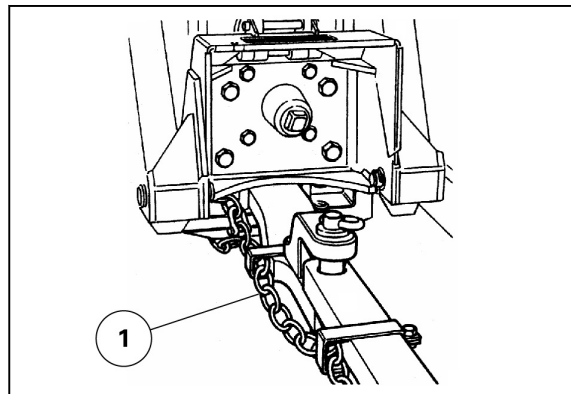

Fig. 20

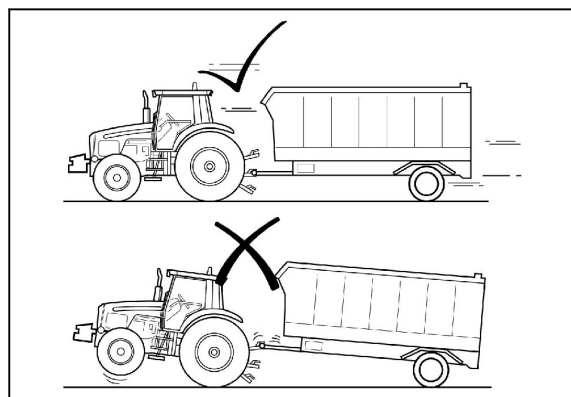

Fig. 21

Towing: permissible load and speed



WARNING: The stopping distance increases with the speed and weight of the trailed implements, and also on a slope.

Whether they are fitted with a brake system or not, trailed implements that are too heavy for the tractor or that are towed at too high a speed may lead to a loss of control.

Take account of the total weight of the trailed implement (including the load).

The maximum permitted trailed weights are indicated on the name plate. In particular, comply with the following loads:

- Trailed weight without brakes: 3000 kg
- Trailed weight with independent brake system: 6000 kg
- Inertia braked trailed weight: 16000 kg
- Trailed weight with braking assistance (hydraulic or pneumatic): 32000 kg

Never tow an implement:

- at a speed exceeding the speed limit in force in the relevant country and
- if the true weight of the tractor/implement assembly is greater than the tractor total permissible loaded weight indicated on the name plate.

Towed equipment without brakes:

Do not tow equipment that does not have brakes:

- at speeds of more than 32 km/h; or
- at speeds above those recommended by the manufacturer; or

1.10 Protective structures

1.10.1 Protective structures - Use and accreditation

The protective structures (ROPS, seat belts) limit injuries as far as possible in case of an accident or if the tractor overturns.

They comply with all the regulations in force for agricultural tractors.

1.10.2 Cab

- The cab has been designed to be suitable for this tractor series and meet all the legal requirements in terms of safety
- Never weld parts onto the cab
- Never bend or straighten the cab
- Never drill or modify the cab to fit accessories or implements.

If other controls or displays have to be fitted in the operator's area of maneuver, contact your dealer to find out what to do

- Do not attach chains or ropes to the cab in order to pull or tow anything
- If the cab has been removed, refit it and tighten the fixings to the specified torque before using the tractor again



WARNING:

A cab damaged as a result of an accident, overturning or other incident must be replaced before using the tractor again.

1.10.3 Seat belt

- Wearing the seat belt is an important part of this protection.
- Always wear the seat belt adjusted correctly.



WARNING: A damaged seat belt must be replaced before using the tractor again.

The seat belt approval number is visible after the seat belt has been completely unraveled.

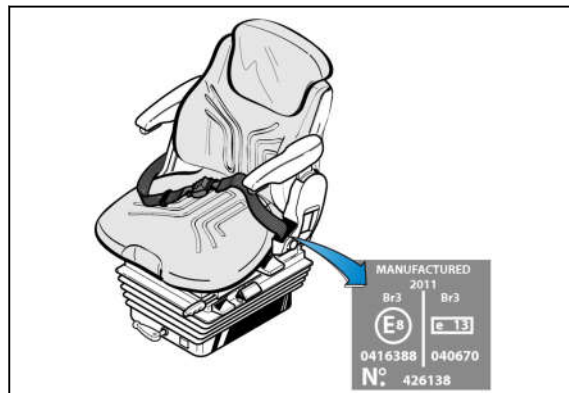

Fig. 39



Frequency	50 hrs	600 hrs ¹	1200 hrs ¹	1800 hrs ²	2400 hrs ²	Every day
Check the clutch pedal and transmission for correct operation.	∞	°				
Check the condition and the brake pipes/ compressed air tank.	∞			°		
Bleed the brakes.				°		
Check the operation of the hand brake.	∞	°				
Replace the 25-micron filter of the high-pressure braking system.	∞	°				
Check the trailer brake valve for correct operation.	∞		°			
Check the regulator filter (pneumatic trailer braking option)		°				
Check the level of WABCOTHYL fluid in the compressed air system.						°
Bleed the air from the pneumatic accumulators of the trailer brake system (if fitted).						°
Front axle and steering						
Check the oil level in the front axle and the front axle final drives.	∞	200 hrs				
Change the oil in the front axle and final drives.	∞		°			
Check the front wheel hubs/steering pivots.		°				
Lubricate the non-suspended front axle.	°7	200 hrs				
Lubricate the front axle drive shaft.	°					
Check the steering and wheel alignment (including tire wear and damage).				°		
Calibrate the suspended front axle.				°		
Power take-off						
Check the PTO for correct operation.	∞	°				
Change the ZUIDBERG front PTO oil.	∞	°4				
Clean the "ZUIDBERG" front PTO strainer.	∞	°				
Check/clean the front PTO cooler.		100 hrs ⁴				
Hitch/linkage						
Check the auto-hitch for correct operation (if fitted).	∞			°		
Check/lubricate the auto-hitch (if fitted).						Once a week
Lubricate the front and rear linkages/hitches.						Once a week
Electrical equipment						
Check the condition of the battery and the electrolyte level.	∞	°				
Check the tightness of the battery connections and battery safety.	∞	°				

IMPORTANT: If the Diesel Exhaust Fluid (DEF) is modified or replaced by another fluid, which does not comply with standards ISO 22241-1 or DIN 70070, there is a risk that it will not provide the intended result and it may damage the SCR Technology.

Fuel storage



WARNING:

Diesel Exhaust Fluid (DEF) fluid must be stored at a temperature below 30°C and away from direct sunlight.

2.3.5 6-cylinder SisuDiesel engine

- (1) Engine oil filter
- (2) Oil filler plug
- (3) Engine oil dipstick
- (4) Fuel prefilter
- (5) Fuel filter

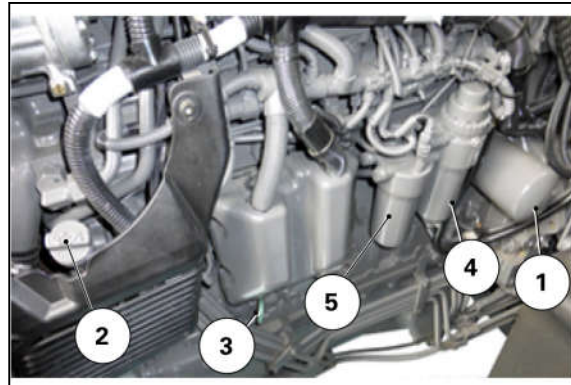

Fig. 8

- (6) Engine oil drain plugs

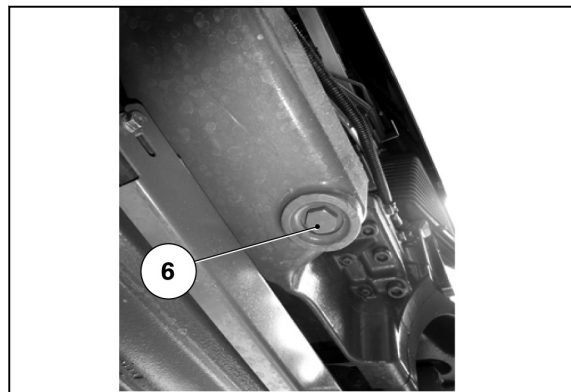

Fig. 9

2.3.6 Engine oil level check

Frequency

Check the engine oil level daily.

AGCO Power engine dipstick

- (1) Minimum
- (2) Maximum

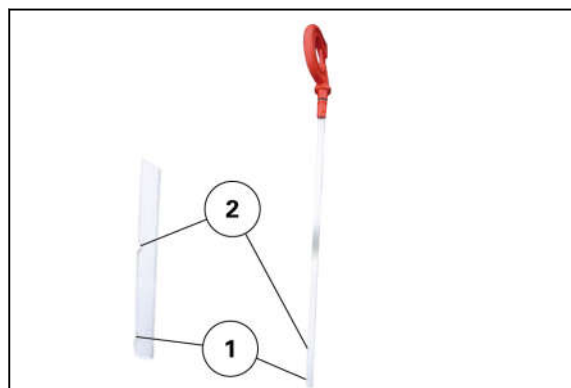

Fig. 10

Procedure

1. Place a container under the prefilter to collect the fuel
2. Undo the bleed screw (1) and fit a transparent pipe onto the port
3. Operate the pump (2) until the liquid flows through the bleed screw without any air
4. Retighten the bleed screw
5. Start the engine and allow it to run at idle for several minutes to completely bleed the system

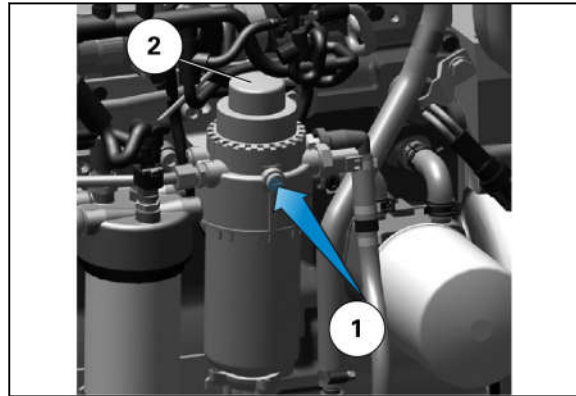

Fig. 30

NOTE:

Never activate the starter for more than 30 seconds in one go to avoid overheating the starter and discharging the battery.

6. Check that there are no leaks
7. Repeat the operation if required.

2.3.16 Fuel system: Injector pump, regulator and injectors

The injection pump, regulator and injectors must be checked and adjusted by the dealer or agent (in accordance with the service guide).

2.3.17 Fuel system: 3rd generation T4F SCR engine injection

The injection system must be checked and adjusted by the dealer or agent (in accordance with the service guide).

2.3.18 Air filter

Cleaning and replacement: Frequency

Main filter

- Only clean the main filter if the blockage indicator light comes on
- Replace the main filter (2) after the blockage indicator light has lit up five times, or once a year.

Secondary filter:

- Only clean the secondary filter if the blockage indicator light comes on
- Replace the secondary filter (3) once for every two main filter changes, or every two years.

**CAUTION:**

Do not use tractor exhaust fumes to blow the main filter or secondary filter out. Never put oil in the main filter or secondary filter. Never use petrol, paraffin or solvents to clean the main filter or secondary filter.

Before installing the main or secondary filter, visually check that there are no cuts, tears or damage on the surface of the seals; do not install the filter if such damage is visible.

2.3.18.1 Cleaning and replacement of the main filter: Procedure

IMPORTANT: Stop the engine before starting work on the filter system.

NOTE: Although the model shown may not fully correspond to your model, the procedure is identical.

Procedure

1. Unscrew the strainer and discard it.
2. Lightly oil the rubber seal of the new strainer; screw on the new strainer until the seal just comes into contact. Tighten a further half-turn. Do not overtighten.

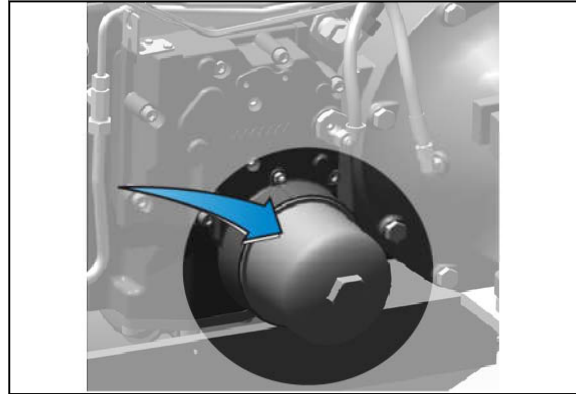

Fig. 49

2.4.4.2 Replacing the 15-micron filter — closed center: Procedure**Procedure**

1. Unscrew the bowl, remove the filter (5), drain it well and discard it.
2. Replace the seal every 1200 hours or as necessary.

NOTE:

Wait 6 minutes for the seal to retract before refitting the bowl.

3. Slide the new filter (5) into the filter head.

NOTE:

To avoid contamination of the new filter by foreign material (mud etc.), do not completely remove the protective plastic until the filter element is in place.

4. Refit the bowl and screw hand-tight until it locks.

2.4.5 Transmission breather

The breather is located behind the hydraulic spool valves on the transmission.

Replace the breather every 1800 hours.

Regularly check that the breather hole is not obstructed.

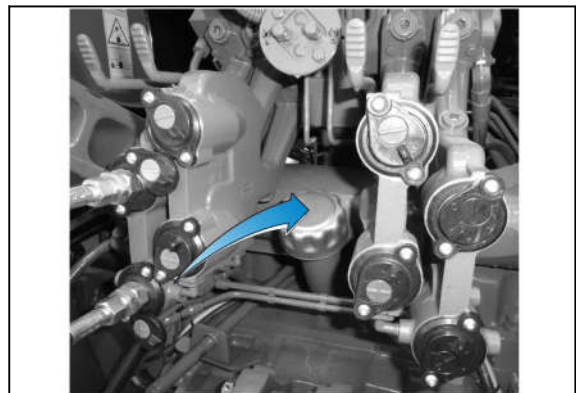

Fig. 50

2.4.6 Checking the level of the rear final drives (depending on model)**Frequency**

Check the oil level in the rear final drive units every 600 hours.

CLICK HERE TO **DOWNLOAD** THE COMPLETE MANUAL

- Thank you very much for reading the preview of the manual.
- You can download the complete manual from: www.heydownloads.com by clicking the link below



- Please note: If there is no response to CLICKING the link, please download this PDF first and then click on it.

CLICK HERE TO **DOWNLOAD** THE COMPLETE MANUAL

2.7 Front axle and steering

2.7.1 Recommended products

IMPORTANT:

The warranty remains valid only as long as the lubricants used comply with the following classifications, and no other products are used.

Front axle

Oil for DANA front axle: Final drives: API GL5; SAE 85W90

Assembled center housing: API GL5; SAE 85W90

Grease

Grease: AGCO M.1105 or lithium multi-purpose grease in accordance with the N.L.G.I. indices :

- N.L.G.I. No. 1: Temperature often drops below 7 °C
- N.L.G.I. No. 2: Temperature often ranges between 7 °C and 27 °C
- N.L.G.I. No. 3: Temperature often exceeds 27 °C

2.7.2 4-wheel drive front axle: Checking the front axle beam oil level

Frequency

Check the front axle beam oil level every 200 hours.

2.7.2.1 Procedure**Procedure**

1. Stand the front axle on level ground.
2. Unscrew the plug (1) and check the level. The oil should be level with the lower rim of the filler plug port. Top up if necessary.

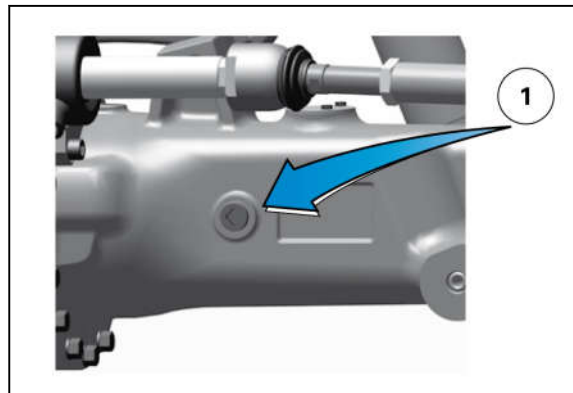

Fig. 69

2.7.3 4-wheel drive front axle: Draining the front axle beam oil

Frequency

Change the front axle beam oil every 1200 hours.

2.7.3.1 Procedure**IMPORTANT:**

Do not dispose of the oil in the environment. Always store oil in suitable containers so that it can be collected and processed by specialist organizations.

Lubrication points

(1) Guides



Fig. 88

(2) Tie rods

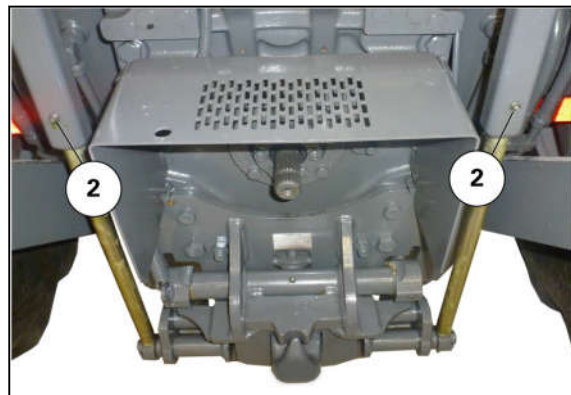

Fig. 89

(3) Rear joints

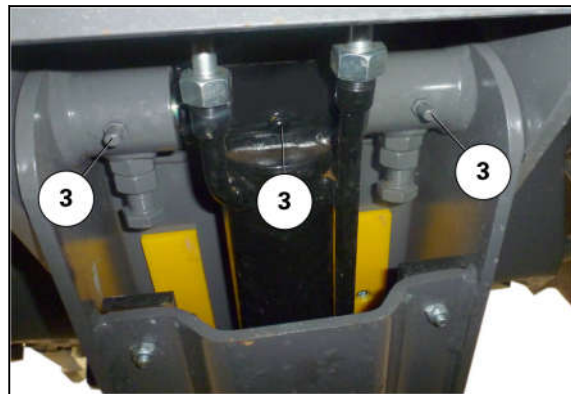

Fig. 90

Number	Amperage	Size	Protected function
F37	10 A	Small	+ BAT <ul style="list-style-type: none"> • X92 - Rear left-hand side light, brake light and direction indicator • X220 - Trailer connection (left-hand side light) • X257 - Side light and direction indicator on hand rail (right and left) • X644 - Left-hand marker lights • X712 - Number plate lights • X819 - Triflash relay control circuit (only on panoramic cabs) • Right-hand console light
F38	3 A	Small	K33 relay control circuit + APC
F39	3 A	Small	K32 relay control circuit + APC
F40	3 A	Small	Not used
F41	5 A	Small	X953 - Cut-off relay for engine controller +APC control and power circuit
F42	10 A	Small	+ APC <ul style="list-style-type: none"> • X58 - Windscreen wiper and direction indicator control unit • X74 - Audible alarm power supply (+12 V APC)
F43	10 A	Small	+ APC <ul style="list-style-type: none"> • X55 - Instrument panel • X717 - Power lift and PTO keypad on pillar
F44	5 A	Small	+ APC <ul style="list-style-type: none"> • X345 - Power supply for additional terminal (Mitron unit) • Aerial Auto-Guide™
F45	5 A	Small	Not used
F46	15 A	Small	K24 relay power circuit supplying the + APC to the brake lights
F47	20 A	Average	Not used
F48	30 A	Average	+ BAT <ul style="list-style-type: none"> • X58 - Windscreen wiper and direction indicator control unit • X250 - In-cab power socket(on the front right-hand wheel arch)
F49	30 A	Average	+ BAT <ul style="list-style-type: none"> • Trailer connector (NA) • X815 - Panoramic cab + APC relay power circuit

Number	Amperage	Size	Protected function
1 - F106 (X340)	200 A	Specific	Cab power supply + BAT
2 - F107 (X196)	175 A	Specific	+BAT X192 - B + alternator 1
3 - F110 (X940)	225 A	Specific	+BAT X241 - AGCO Power engine preheating supply (Grid Heater)
4 - F109 (X251)	175 A	Specific	+BAT X193 - B + alternator 2
5		Specific	BUSBAR +BAT or not used
6 - F104	25 A	Average	+BAT X185 - Engine controller AGCO Power
7 - F105	70 A	Large	K106 relay power circuit
8 - F111	10 A	Average	Not used
9 - F112	10 A	Average	Turbocharger wastegate power supply
10 - F113	10 A	Average	+BAT supply <ul style="list-style-type: none"> • X581 - NOx sensor – downstream • X582 - NOx sensor – upstream • X616 - Diesel Exhaust Fluid (DEF) tank gage with quality sensor (Only for North America)
11 - F114	3 A	Average	X185 - Engine controller earth protectionAGCO Power
12 - F115	25 A	Average	K107 relay power circuit
K106			Starter relay
K107			Supply relay <ul style="list-style-type: none"> • X289 - Diesel Exhaust Fluid (DEF) supply module • X577 - Diesel Exhaust Fluid (DEF) pressure lines heater
K108			X185 - Engine controller earth relayAGCO Power
K109			Supply relay for fuses F111, F112 and F113

Additional fuses/relays

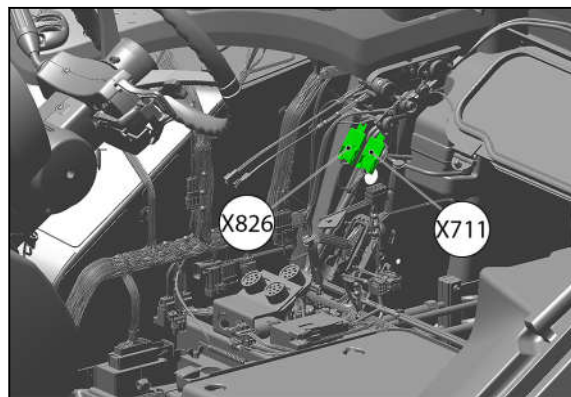





Fig. 105

Filter blocked	Change the filter element.
Transmission oil polluted	Check the quality of the oil.
High-pressure transmission oil filter blockage switch faulty (error code T4150)	Check the blockage switch.

 Differential lock indicator light	
Activating condition(s) <ul style="list-style-type: none"> • Indicator light permanently on = differential lock engaged • Indicator light flashing quickly = differential lock error 	
Cause(s)	Solution(s)
Error in one of the components	Contact the dealer.

 Rear PTO engaged indicator light	
Activating condition(s) <ul style="list-style-type: none"> • Indicator light flashing slowly = rear PTO pre-engaged • Indicator light permanently on = rear PTO engaged • Indicator light flashing quickly = rear PTO error 	
Cause(s)	Solution(s)
Error in one of the components	Contact the dealer.

 Brake pressure indicator light (ParkLock) and air brakes	
Activating condition(s) <ul style="list-style-type: none"> • Indicator light permanently on = pressure in pneumatic or hydraulic brake system too low 	
Cause(s)	Solution(s)
Air brake pressure system below 4 bar	Check the condition of the air connection couplers with the implement, the implement braking system and the pneumatic braking system.
Pressure in ParkLock brake system lower than 70 bar, the ParkLock does not disengage.	Check the hydraulic brake system, and disengage the ParkLock mechanically in order to move the tractor.
Braking pressure sensor faulty	Contact the dealer.

Function

A number is assigned to each of the tractor functions:

Function number	Function
0	Instrument panel
3	Armrest
4	Transmission
5	Front axle and differential lock
6	Rear power take-off (PTO)
7	Front power take-off
8	Rear linkage
9	Front linkage
A	Hydraulic spool valve
10	Automatic air conditioning
13	ParkLock (depending on model)
14	High-pressure braking
1B	Keypad in the pillar

Severity

3 severity levels change the way the alert is raised in the cab.

Severity	Alert in cab
0	Display on the instrument panel and audible alert
1	Display on the instrument panel
2	No display (but display possible via the Setup and Information Screen)

Severity level

IMPORTANT:

When an error code for a hydraulic spool valve is displayed, the severity level is preceded by a number. This figure corresponds to the number of the hydraulic spool valve that is faulty.

Fault code

The fault code indicates the fault and the faulty component.

2.14.5 Instrument panel error codes Dyna-4/Dyna-6

No.	Components concerned	Causes
0.X.30		Alternator regulator voltage too high or too low (filtered battery signal).
0.X.31	X197 - Diesel fuel gauge	Electrical signal too high or too low.
0.X.32		Battery voltage too high or too low (non-filtered battery signal)

No.	FMI	Components concerned	Causes	Stand ard modes	modes
3509	31	EEM4 controller	5 V DC supply 1 out of range		
3510	31	EEM4 controller	5 V DC supply 2 out of range		
3511	31	EEM4 controller	5 V DC supply 3 out of range		
3512	3	EEM4 controller	12 V supply 1 above normal		
3512	4	EEM4 controller	12 V supply 1 below normal		
3515	3	Diesel Exhaust Fluid (DEF) tank temperature sensor	Open circuit		
3515	4	Diesel Exhaust Fluid (DEF) tank temperature sensor	Short circuit		
3515	11	Diesel Exhaust Fluid (DEF) tank temperature sensor	General error		
3515	15	Diesel Exhaust Fluid (DEF) tank temperature sensor	Error		
3515	(17)	Diesel Exhaust Fluid (DEF) tank temperature sensor	Error		
3516	2	quality sensor	Diesel Exhaust Fluid (DEF) concentration error		
3516	11	quality sensor	General error		
3516	15	quality sensor	Incorrect concentration		
3516	(17)	quality sensor	Incorrect concentration		
3516	19	quality sensor	Loss of the CAN message from the quality sensor		
3519	3	Diesel Exhaust Fluid (DEF) tank temperature sensor	Sensor in open circuit		
3519	4	Diesel Exhaust Fluid (DEF) tank temperature sensor	Sensor short-circuited		
3521	14	quality sensor	Unknown liquid		
3521	16	quality sensor	Concentration of Diesel Exhaust Fluid (DEF) too high		
3521	18	quality sensor	Concentration of Diesel Exhaust Fluid (DEF) too low		
3521	31	quality sensor	Presence of fuel in the Diesel Exhaust Fluid (DEF) tank		
3532	3	tank gage	Open circuit		
3532	4	tank gage	Short circuit		
3562	14	Boost pressure sensor 2	Boost pressure inconsistent	2	
3562	31	Boost pressure sensor 2	Boost pressure inconsistent	2	
3573	3	Air dosing unit 2	Voltage above normal	1	
3573	4	Air dosing unit 2	Voltage below normal	1	
3573	13	Air dosing unit 2	Calibration error	1	

No.	Components concerned	Causes
13.X.44	X672 - ParkLock solenoid valve when stationary	Open circuit
13.X.45	X672 - ParkLock solenoid valve when stationary	Short circuit to +12 V
13.X.46	X671 - ParkLock solenoid valve in road mode	Short circuit to +12 V
13.X.47	X674 - ParkLock status switch	Locked in open position
13.X.48	X674 - ParkLock status switch	Locked in closed position
13.X.49	X673 - ParkLock wear switch	Locked in closed position
13.X.4A	X72 - ParkLock switch on Power Control lever	Locked in closed position

2.14.9 Front axle error codes for Dyna-4/Dyna-6

No.	Components concerned	Causes
5.X.80	X104 - TECU controller	Absence of calibration
5.X.81	X166 - Suspended front axle position sensor	The signal is too high
5.X.82	X166 - Suspended front axle position sensor	The signal is too low
5.X.83	X166 - Suspended front axle position sensor	Incorrect values during calibration
5.X.84	X166 - Suspended front axle position sensor	Values too high during calibration

2.14.10 Power take-off error codes Dyna-4/Dyna-6

No.	Components concerned	Causes
6.X.04	X7 - Rear PTO solenoid valve	Short circuit to +12 V
6.X.06	X7 - Rear PTO solenoid valve	Shortcut to Ground
6.X.07	X7 - Rear PTO solenoid valve	Open circuit
6.X.08		Excessive drop in engine speed when engaging the power take-off
6.X.09		PTO switch is activated but the PTO is not activated
6.X.4A		The PTO speed engaged does not match the selected speed
6.X.E2		Engine speed too high (> 1780 rpm) in economy power take-off mode
6.X.E7		Checksum error for the operating temperatures and the clutch times of the rear power take-off

3. Technical specifications

3.1 General specifications	193
3.1.1 Model MF 7720 S Dyna-6	193
3.1.2 Model MF 7722 S Dyna-6	194
3.1.3 Model MF 7724 S Dyna-6	195
3.1.4 Model MF 7726 S Dyna-6	196
3.2 Operator environment	198
3.2.1 Noise levels (dB(A))	198
3.2.2 Level of vibration felt through the seat	198
3.3 Engine	199
3.3.1 Engine specifications	199
3.3.2 Fuel system and air filter	200
3.3.3 Cooling	200
3.3.4 Tightening torques	200
3.4 Transmission	201
3.4.1 Forward speed at maximum speed with Dyna-6 40 kph transmission: and 20.8R42 tires	201
3.4.2 Forward speed at maximum speed with Dyna-6 50 kph transmission: and 20.8R42 tires	202
3.4.3 Forward speed with Dyna-6 transmission, 40 kph and 50 kph with creeper speed option and 20.8R42 tires	204
3.4.4 Forward speed with Dyna-6 transmission, 40 kph and 50 kph, creeper speed option and 650/85R38 tires	206
3.4.5 Gearbox	206
3.4.6 Final drives	207
3.4.7 Rear differential lock	207
3.5 Brakes	208
3.5.1 Brake system technical specifications	208
3.6 Front axle and steering	209
3.6.1 Four-wheel drive front axle	209
3.6.2 Steering	209
3.7 Power take-off	210
3.7.1 Specifications	210
3.7.2 Tightening torques	211
3.8 Linkage	212
3.8.1 Front linkage	212
3.8.2 Rear linkage	212
3.9 Auxiliary hydraulics	213
3.9.1 Hydraulic system	213
3.10 Electrical equipment	214
3.10.1 Electrical equipment technical specifications	214
3.10.2 Layout of components	214
3.11 Wheels and tires	216
3.11.1 Rims	216
3.11.2 Tires	216
3.11.3 Tires, front/rear compatibility	216
3.11.4 Tightening torques	216
3.12 Capacities and dimensions	218
3.12.1 Capacities for models with a Tier 4F/Stage IV SCR Technology engine	218
3.12.2 Dimensions and weights	219
3.12.3 Attachment points: Dyna-6 models without front linkage	226
3.12.4 Attachment points: Dyna-6 models with 4 t front linkage (Imperial: 4.4 US ton)	227

3.4 Transmission

3.4.1 Forward speed at maximum speed with Dyna-6 40 kph transmission: and 20.8R42 tires

Forward and reverse travel, Dyna-6 transmission

Range	Ratio	GTA 1541 - /MF 7720 S	GTA 1542 - MF 7722 S
1	A	1,69 km/h	1,67 km/h
1	B	2,04 km/h	2,01 km/h
1	C	2,39 km/h	2,36 km/h
1	D	2,88 km/h	2,83 km/h
1	E	3,38 km/h	3,33 km/h
1	F	4,07 km/h	4,01 km/h
2	A	4,58 km/h	4,51 km/h
2	B	5,50 km/h	5,43 km/h
2	C	6,46 km/h	6,37 km/h
2	D	7,77 km/h	7,66 km/h
2	E	9,14 km/h	9,01 km/h
2	F	11,00 km/h	10,84 km/h
3	A	8,77 km/h	8,64 km/h
3	B	10,54 km/h	10,39 km/h
3	C	12,37 km/h	12,19 km/h
3	D	14,89 km/h	14,67 km/h
3	E	17,51 km/h	17,26 km/h
3	F	21,07 km/h	20,76 km/h
4	A	24,33 km/h	23,99 km/h
4	B	29,26 km/h	28,84 km/h
4	C	29,00 km/h	33,85 km/h
4	D	41,32 km/h ^[1]	40,73 km/h ^[1]
4	E	-	-
4	F	-	-

[1] The speed limit is governed by the engine's electronic management system.

Forward and reverse travel, Dyna-6 transmission

Rear power take-off	
Engine speed for 540E power take-off	1524 rpm
Engine speed for 1000 power take-off	/MF 7720 S /MF 7722 S >2000 rpm MF 7724 S/MF 7726 S >1930 rpm
Engine speed for 1000E power take-off	1595 rpm

3.7.2 Tightening torques

Rear PTO shaft retaining screw	69 Nm
--------------------------------	-------

Reference	Measured specification	Dimension/weight	
		Rear Axle	Front axle
			Dana 750/755
(H)	Center-to-center distance between studs - flanged shaft - straight shaft	275 mm 335 mm	335 mm
(I)	Centring diameter - flanged shaft - straight shaft	221 mm 281 mm	280 mm
(J)	Stud length - flanged shaft - straight shaft	41 mm to 66 mm 53 mm to 71 mm	50 mm
(K)	Stud diameter	M22x1.5	M22x1.5
(L)	Number of studs (per side) - flanged shaft - straight shaft	8 10	10

MF 7700 S Dyna-6

Weights and tires, point 2.2.3.1 front axle beam								
Tire designations	Load index	Index radius (mm)	Speed index	Tire load capacity (ETRTO)		Maximum weight technically permissible depending on tire fittings		
				By tire	By axle beam	/MF 7720 S/ MF 7722 S/MF 7724 S/ MF 7726 S	MF 7722 S/MF 7724 S	MF 7724 S/MF 7726 S
						S	S	S
14.9R28	128	650	A8	1800	3600	3600	3600	3600
230/95R36	130	650	A8	1900	3800	3800	3800	3800
380/85R28	133	650	A8	2060	4120	4120	4120	4120
380/85R28	133	650	A8	2060	4120	4120	4120	4120
400/80R28	146	650	A8	3000	6000	6000	6000	6000
420/70R28	133	650	A8	2060	4120	4120	4120	4120
420/85R26	138	650	A8	2360	4720	4720	4720	4720
480/65R28	139	650	A8	2430	4860	4860	4860	4860
520/60R28	134	650	A8	2120	4240	4240	4240	4240
520/60R28	138	650	B	2360	4720	4720	4720	4720

CLICK HERE TO **DOWNLOAD** THE COMPLETE MANUAL

- Thank you very much for reading the preview of the manual.
- You can download the complete manual from: www.heydownloads.com by clicking the link below



- Please note: If there is no response to CLICKING the link, please download this PDF first and then click on it.

CLICK HERE TO **DOWNLOAD** THE COMPLETE MANUAL