



CLICK HERE TO **DOWNLOAD** THE COMPLETE MANUAL

- Thank you very much for reading the preview of the manual.
- You can download the complete manual from: [www.heydownloads.com](http://www.heydownloads.com) by clicking the link below



- Please note: If there is no response to CLICKING the link, please download this PDF first and then click on it.

CLICK HERE TO **DOWNLOAD** THE COMPLETE MANUAL

# Safety

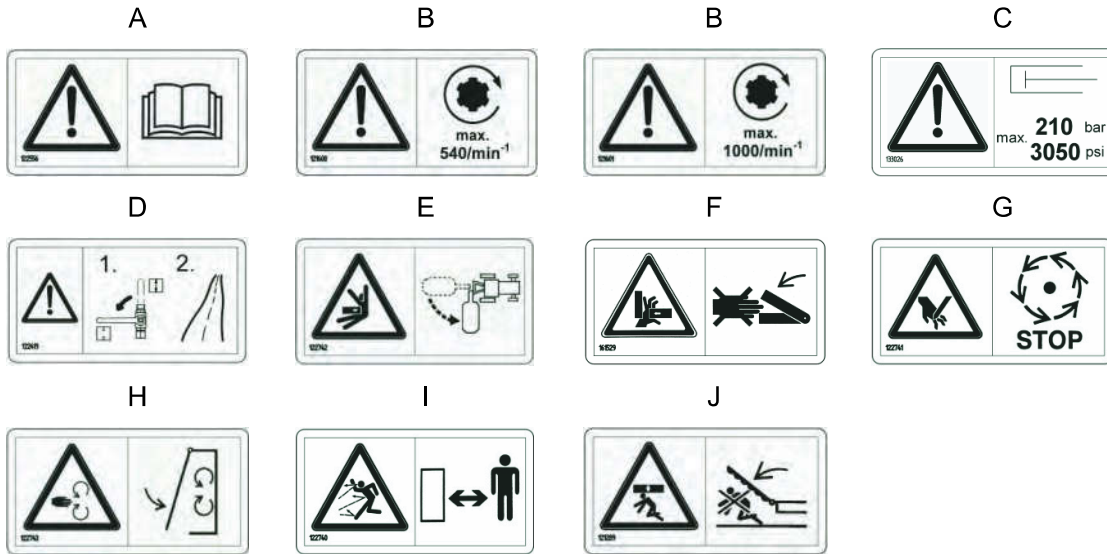

Fig. 6 Operating instructions

Before using the machine for the first time, **read** the operating instructions and safety instructions. Always **observe** the operating instructions and safety instructions while using the equipment.



Fig. 7 Drive speed

**Do not exceed** the maximum permitted drive speed of 540 rpm or 1000 rpm.



Fig. 8 Hydraulic pressure

**Do not exceed** the maximum permitted hydraulic pressure of 210 bar/3050 psi.

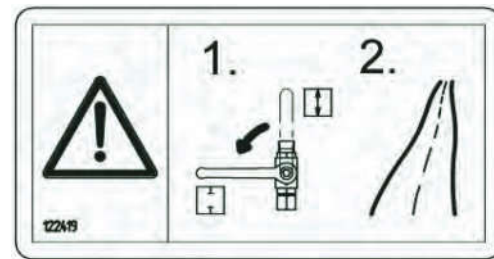

Fig. 9 Shut off the hydraulic line

Use the stop valve to **lock** the **hydraulic line** before travelling on the roads.

## 5 Before initial operation

### 5.1 Assembling the machine

The machine is partially assembled when it is delivered from the factory. Your dealer will receive a set of assembly instructions with the machine and is responsible for making sure the machine is assembled correctly.



#### Warning!

#### Risk of injury as a result of incorrect assembly

Improper assembly may lead to malfunctions and damage to the machine, which could result in injury to persons.

- ➔ The machine must only be assembled by trained personnel or specialist workshops in accordance with the assembly instructions.
- ➔ Contact your dealer if the machine needs to be assembled or disassembled.

### 5.2 Adjusting the PTO shaft



#### Warning!

#### Risk of injury as a result of incorrect installation

Incorrect installation of the PTO shaft may cause personal injury and material damage.

- ➔ Only PTO shafts which have been approved by the manufacturer may be used for this machine.
- ➔ Follow the PTO shaft manufacturer's operating instructions.
- ➔ Before each use, check that the PTO shaft is fitted and functioning correctly and that the protection devices are complete.



#### Important!

#### Risk of material damage as a result of damage to the PTO shaft

The PTO shaft may be damaged if:

- The PTO shaft is too long or too short,
  - The curved barrel cover is too small,
  - The drive speed is too high, or
  - It has been inadequately maintained.
- ➔ Check the length and barrel cover of the PTO shaft.
  - ➔ Always take the maximum permissible drive speed into account.
  - ➔ Follow the PTO shaft manufacturer's operating instructions.

As supplied, the PTO shaft is the maximum length. It is therefore possible to adjust the PTO shaft on different tractors.

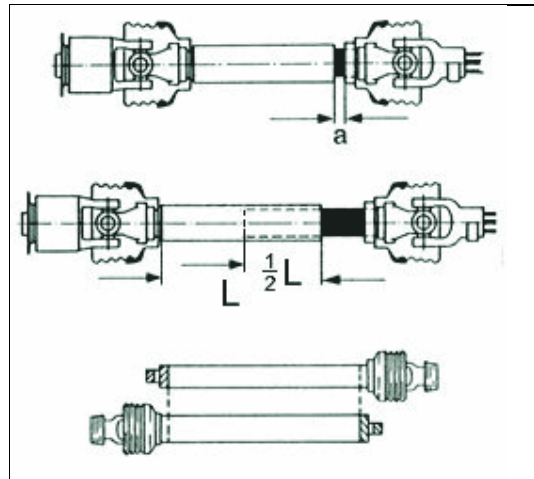

Fig. 27 PTO shaft minimum measurements

The length of the PTO shaft must be adjusted so that:

- The profile tubes overlap by at least half their length  $L$  in the longest operating state.
- In the shortest operating state, the safety distance to the yoke end of the universal joint is still  $a = 25 \text{ mm}$ .

## Settings

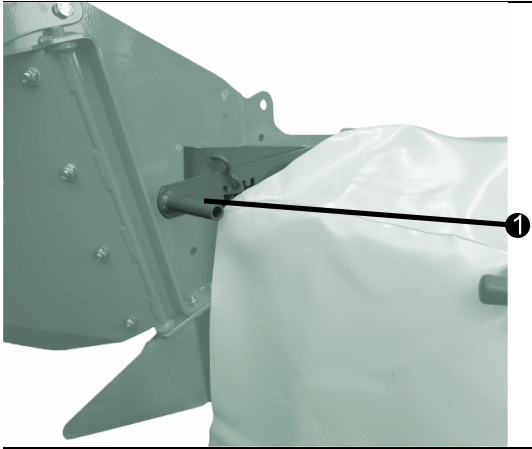
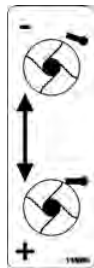

Fig. 43 KC adjusting bar

→ Move the adjusting bar (1) to adjust the conditioner intensity.

- Backwards → Reduced intensity

+ Forwards → Greater intensity



### 9.3.2 Adjusting the swath guiding assembly

You can set the swath width using the swath boards. It is infinitely variable.

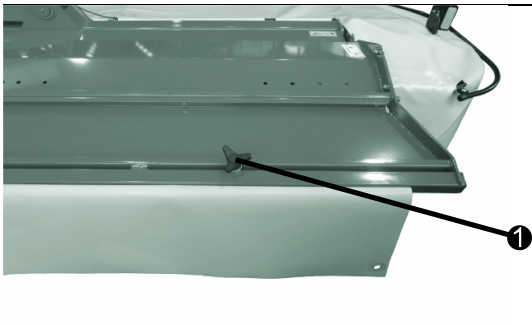

Fig. 44 KC swath guiding assembly

→ Undo the three-arm knob(1).

→ Slide the three-arm knob (1) and the swath board to the required width, and lock in position using the three-arm knob.

## 9.4 Adjusting conditioners with rubber rollers (RC)

### 9.4.1 Adjusting the conditioner intensity

The clearance between both rubber rollers determines the intensity of the conditioner – infeed and ejection of the crop. It can be adjusted using the two adjustment screws on the left- and right-hand side of the roller conditioner.



Fig. 45 Clearance between rollers

The clearance between the rubber rollers is measured between the profile on the one roller and the groove on the other. The clearance should be between 5 and 7 mm.

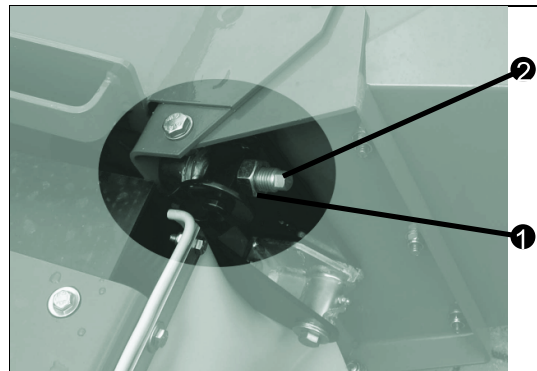

Fig. 46 Adjusting the RC conditioner intensity, left

### Installation

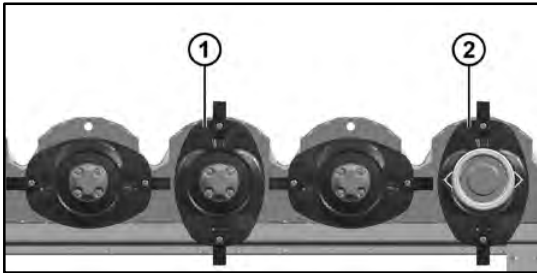

Fig. 70 Mower discs aligned

- Align mower disc (1) parallel to mower disc (2).



Fig. 71 Insert new driveGUARD element

- Insert a new driveGUARD element (1).

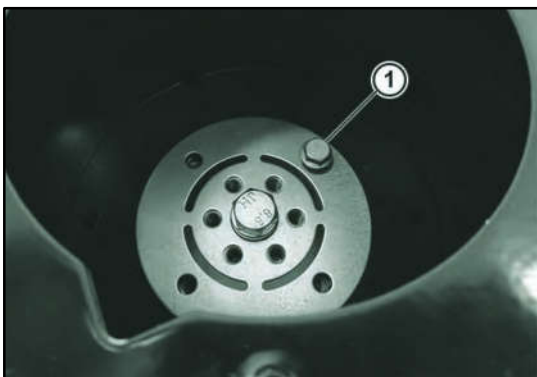

Fig. 72 Position of the new driveGUARD element

- Position the new driveGUARD element as shown.
- Make sure that all fastening holes of the driveGUARD element line up with the bolt holes of the mower disc.

- Insert the stop pin back into the respective mower disc.
- Insert a bolt (1) into the outer bolt circle to prevent the element from turning.

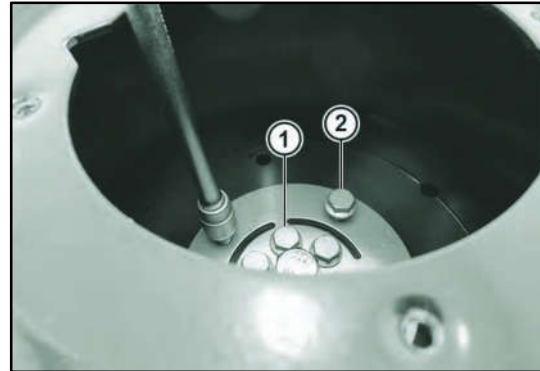

Fig. 73 Tighten bolts

- Tighten the 6 inner bolts (1) in a crosswise sequence. Observe the tightening torque of 110 Nm.



### Important!

#### Risk of material damage from incorrect tightening sequence!

An incorrect tightening sequence of the inner bolts can bend the driveGUARD element out of shape or destroy it.

- Always tighten the inner bolts in a crosswise sequence.

- Tighten the 4 outer bolts (2). Observe the tightening torque of 110 Nm.



Fig. 74 Bolt down cover

- Place the cover (1) on the feed drum.
- Tighten the 4 bolts (2).
- Remove the stop pin.

## Servicing



### Note

A key is provided for the quick-change blade system.

- ➔ Use the key provided for replacing the cutter blades.
- ➔ Remove any dirt from around the cutter-blade attachment.

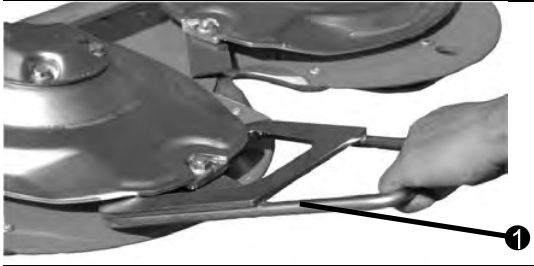

Fig. 91 Inserting the key

- ➔ Insert the key (1).



Fig. 92 Removing the cutter blades

- ➔ Turn the key (1) upwards.
- ➔ Remove the used cutter blade (2).

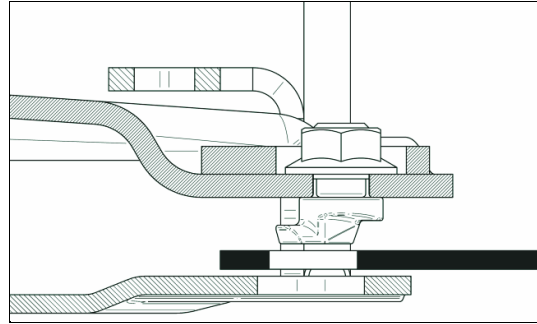

Fig. 93 Cutter blade on the blade retaining bolt

- ➔ Slide the new cutter blade over the blade retaining bolt.

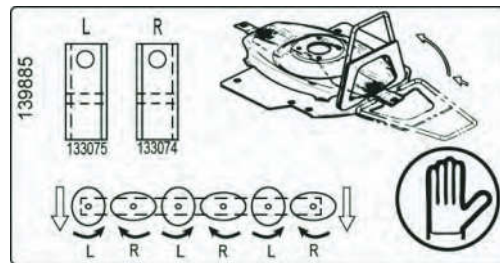

Fig. 94 Direction of rotation of the cutter discs

- ➔ Observe the direction of rotation of the mower disc.
- ➔ Turn the key downwards and remove it.

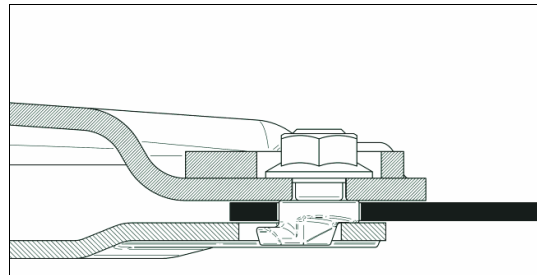

Fig. 95 Checking the cutter blade seating

- ➔ Check whether the cutter blade is correctly positioned on the blade retaining bolt.

CLICK HERE TO **DOWNLOAD** THE COMPLETE MANUAL

- Thank you very much for reading the preview of the manual.
- You can download the complete manual from: [www.heydownloads.com](http://www.heydownloads.com) by clicking the link below



- Please note: If there is no response to CLICKING the link, please download this PDF first and then click on it.

CLICK HERE TO **DOWNLOAD** THE COMPLETE MANUAL