

# 350 X2 HYDRAULIC EXCAVATOR OPERATOR'S MANUAL

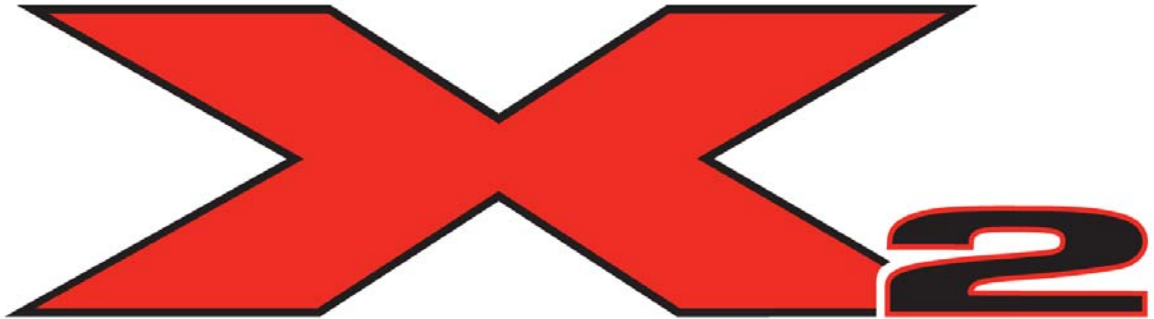

## **LINK-BELT TECHNICAL MANUALS**

Manuals are available from the Dealer for the operation, service, and repair of the excavator. For prompt convenient service, contact the Dealer for assistance in obtaining the manuals for the excavator.

The Dealer can expedite orders for Operator's Manuals, Parts Manuals, Service Manuals, and Maintenance records.

Always give the model number, excavator serial number, and manufacturer's number of your excavator so your Dealer can provide the correct manuals for your excavator.

**Book Number 2108**

**NOTE:** *LBX COMPANY LLC reserves the right to make improvements in design or changes in specifications at any time without incurring any obligation to install them on units previously sold.*

CLICK HERE TO **DOWNLOAD** THE COMPLETE MANUAL

- Thank you very much for reading the preview of the manual.
- You can download the complete manual from: [www.heydownloads.com](http://www.heydownloads.com) by clicking the link below



- Please note: If there is no response to CLICKING the link, please download this PDF first and then click on it.

CLICK HERE TO **DOWNLOAD** THE COMPLETE MANUAL

## IDENTIFICATION NUMBERS

### TYPE, SERIAL NUMBER AND YEAR OF MANUFACTURE

When ordering parts, obtaining information or assistance, always supply your LBX Link-Belt dealer with the type and serial number of your excavator or accessories.

Write the following in the spaces below: The model number, serial number, and manufacturer's number of your excavator, and the make/model and serial numbers of the engine.

### Excavator Identification Locations



### EXCAVATOR SERIAL NUMBER AND ENGINE SERIAL NUMBER

|                           |  |
|---------------------------|--|
| A - Model Number          |  |
| A - Serial Number         |  |
| A - Manufacturer's Number |  |
| B - Engine Make and Model |  |
| B - Engine Serial Number  |  |

**IMPORTANT:** If the excavator serial number plate is missing or unreadable the manufacturer's number is stamped on the frame (C) of the machine.

## SEAT BELT PRECAUTIONS



LBX002

Figure 4

1. RIGHT BELT STRAP
2. LATCH MECHANISM
3. RELEASE LEVER

1. To latch the seat belt, pull the right belt strap to the latch mechanism.
2. Insert the metal end into the latch mechanism on the left side of the seat.
3. To unlatch the seat belt, press the release lever on the right belt strap.
4. The seat belt will come apart.



**WARNING:** Before starting the engine ensure seat belts are securely fastened. The seat belt can help ensure your safety if it is used and properly maintained. Never wear a seat belt loosely or with slack in the belt system. Never wear the belt in a twisted condition or pinched between the seat structural members.

M422A

## QUICK COUPLER PRECAUTIONS

- Always follow the safety procedures of the quick coupler manufacturer if you have one on your machine. See Quick Coupler Operation.

## ENGINE PRECAUTIONS

- The fuel system on the engine is under heavy PSI. Do Not open the high pressure fuel lines with the engine running.

## SPECIFIC PRECAUTIONS TO THIS EXCAVATOR

- Keep the load or tool as low as possible while moving the excavator around the jobsite.
- Never smoke while refueling.

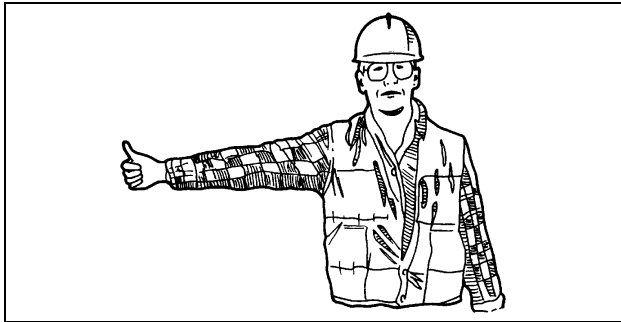

PDE0010A

Figure 44

**RAISE TOOL**

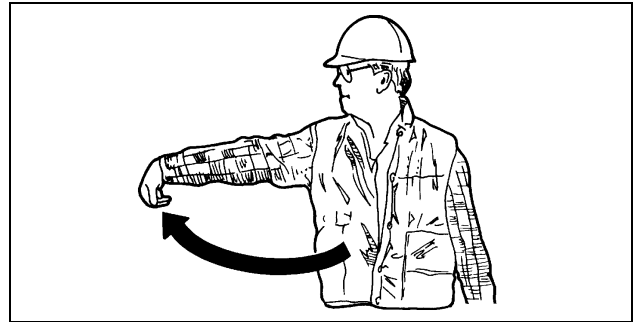

PDE0011

Figure 47

**EXTEND ARM**

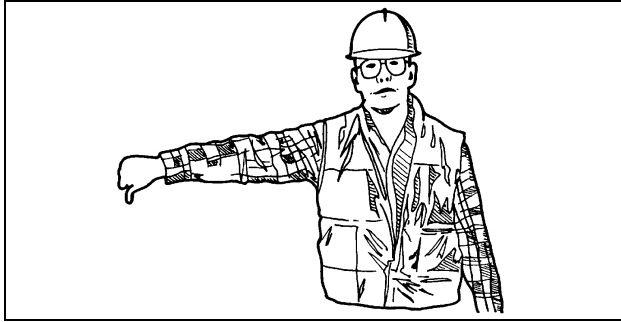

PDE0010

Figure 45

**LOWER TOOL**

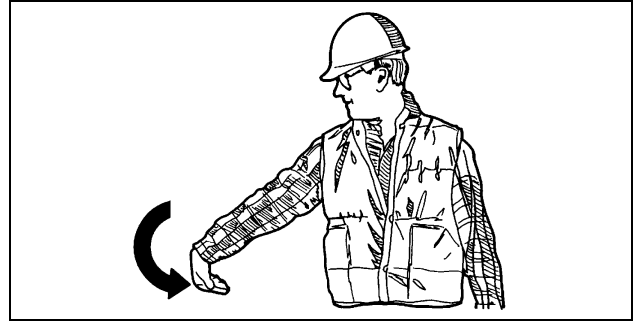

PDE0012A

Figure 48

**FILL TOOL**

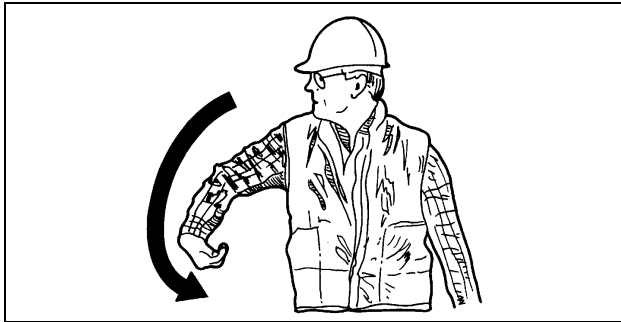

PDE0011A

Figure 46

**RETRACT ARM**

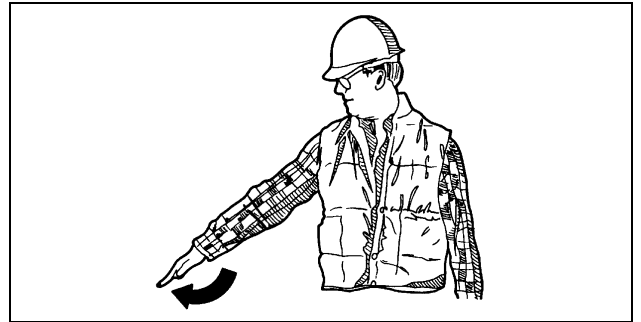

PDE0012

Figure 49

**EMPTY TOOL**

## INSTRUMENT PANEL

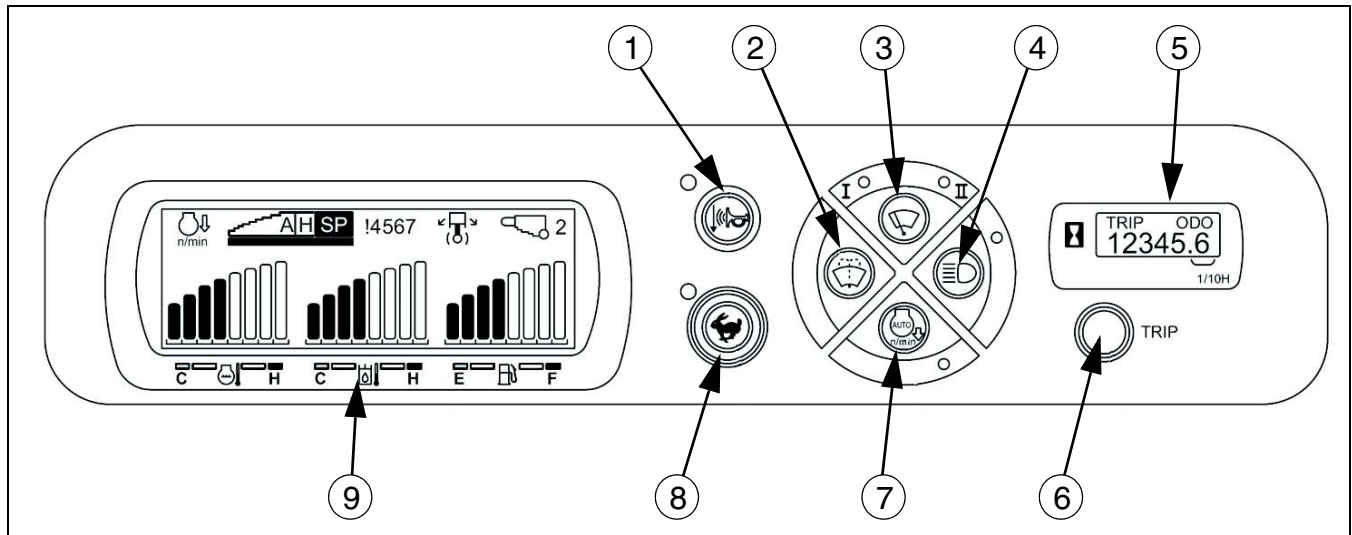

Figure 10



**WARNING:** The role of the instrument panel is to indicate the state of the excavator and quickly warn the operator in case of any malfunction, through alarms.

The instrument panel is not waterproof. Make sure that it does not get wet

#### 1. HORN VOLUME CONTROL

This button controls the volume of the horn. When you press the button a beep will occur and the light will illuminate. If the green light is on then horn is in low, if the light is not illuminated then it is normal volume.

The horn volume will remain the same after the engine is shut down.

#### 2. WINDOW WASHER CONTROL

When pressed this button applies washer fluid to the windshield and turns the wipers on.

**WARNING:** Do not use the window washer if the reservoir is empty. It can cause damage to the window washer pump.

#### 3. WINDOW WIPERS CONTROL

This button controls the window wipers. There are three settings:

**I** - Intermittent wipers

**II** - Continuous wipers

No lights - wipers are off.

**IMPORTANT:** Do not run the window wipers on a dry window for it can cause damage to the wipers and window.

#### 4. WORKING LIGHT CONTROL

This button controls the working lights on the machine. When the light is on the working lights are on.

#### 5. HOURMETER

This display shows the total elapsed operating time of the engine.

#### 6. TRIP CONTROL

The TRIP button when pressed will show the trip hours for one minute, then return to the hour meter. To reset the trip, hold the button down for two seconds.

#### 7. AUTOMATIC AUTO-IDLE SWITCH

When the button is pressed a beep will sound and the light will illuminate and it will be in auto-idle mode. The machine will run at idle when the controls are in the neutral position for 5 seconds. When the controls are re-engaged, the engine rpms will return to the previous setting. The machine will stay in the same mode when the engine is turned off.

#### 8. TRAVEL MODE CONTROL

This button toggles between Low speed travel and High speed travel. When the light is off it is in Low speed when the light is on it is in High speed travel. When the engine is shut down it resets to Low speed.

**IMPORTANT:** It is best to change travel speeds while the machine is not moving, changing speeds while traveling may cause erratic movement of the machine.

#### 9. DISPLAY MONITOR

For more details see Computer Monitor Display on the next page.

### ARM AND UPPERSTRUCTURE SWING LEFT-HAND CONTROL LEVER IN PATTERN C

The speed of movement of the arm or the upperstructure swing depends on the control lever tilt angle. In the intermediate position both movements can be obtained simultaneously.

1. The boom lowers.
2. The boom raises.
3. The upperstructure turns towards the left.
4. The upperstructure turns towards the right.

**NOTE:** The movements of the excavator are shown in the Control functions decal. See Decals.

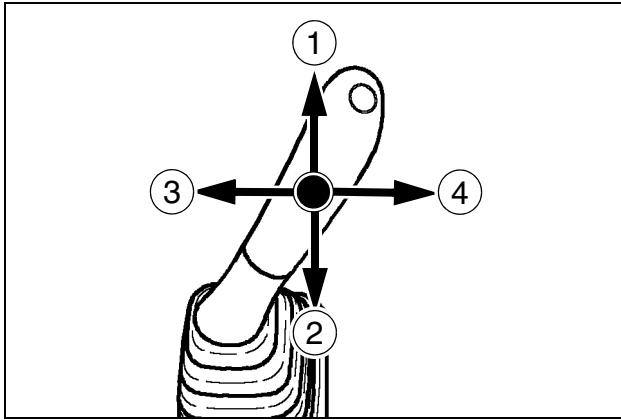

CT02C039

Figure 23

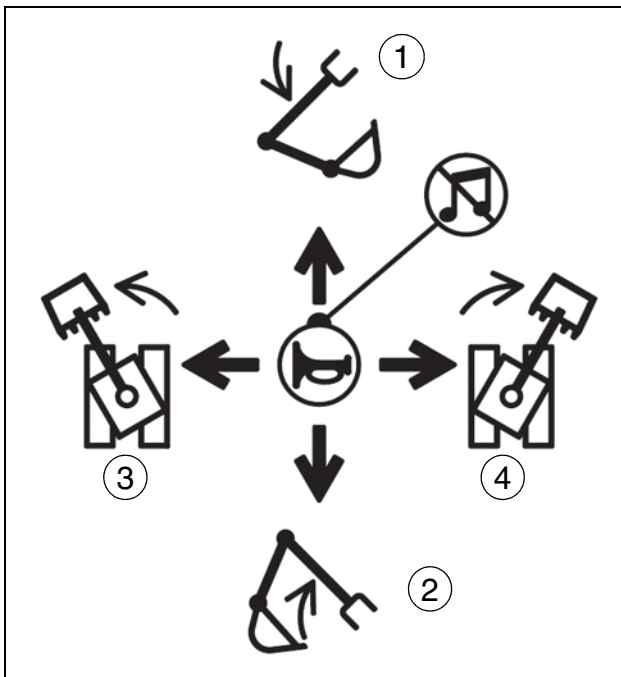

CS98M554

Figure 24

### BOOM AND BUCKET RIGHT-HAND CONTROL LEVER IN PATTERN C

The speed of movement of the boom or the tool depends on the control lever tilt angle. In the intermediate position both movements can be obtained simultaneously.

5. The arm extends
6. The arm retracts.
7. The bucket retracts (filling).
8. The bucket extends (dumping).

**NOTE:** The movements of the excavator are shown in the Control functions decal. See Decals.

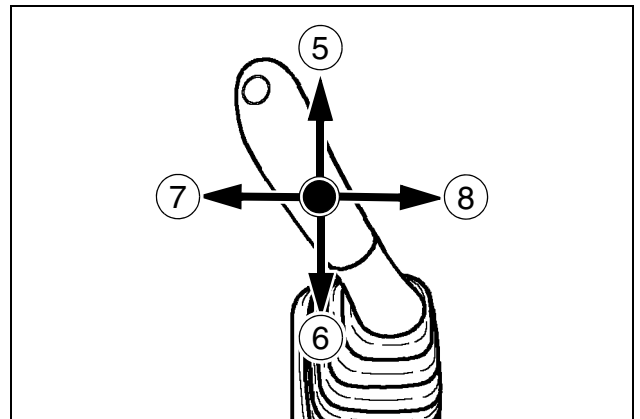

CT02C040

Figure 25

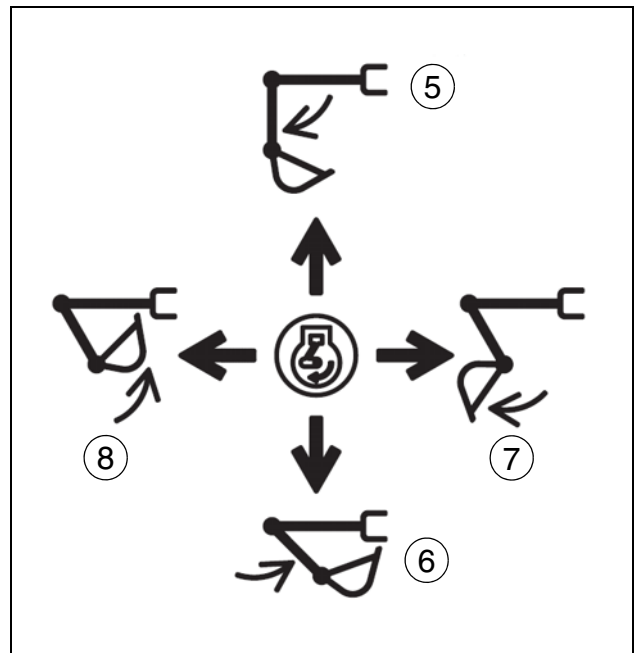

CS98M554

## REAR VIEW MIRRORS

**IMPORTANT:** Before any travel operation, make sure that the rear view mirrors are correctly adjusted.

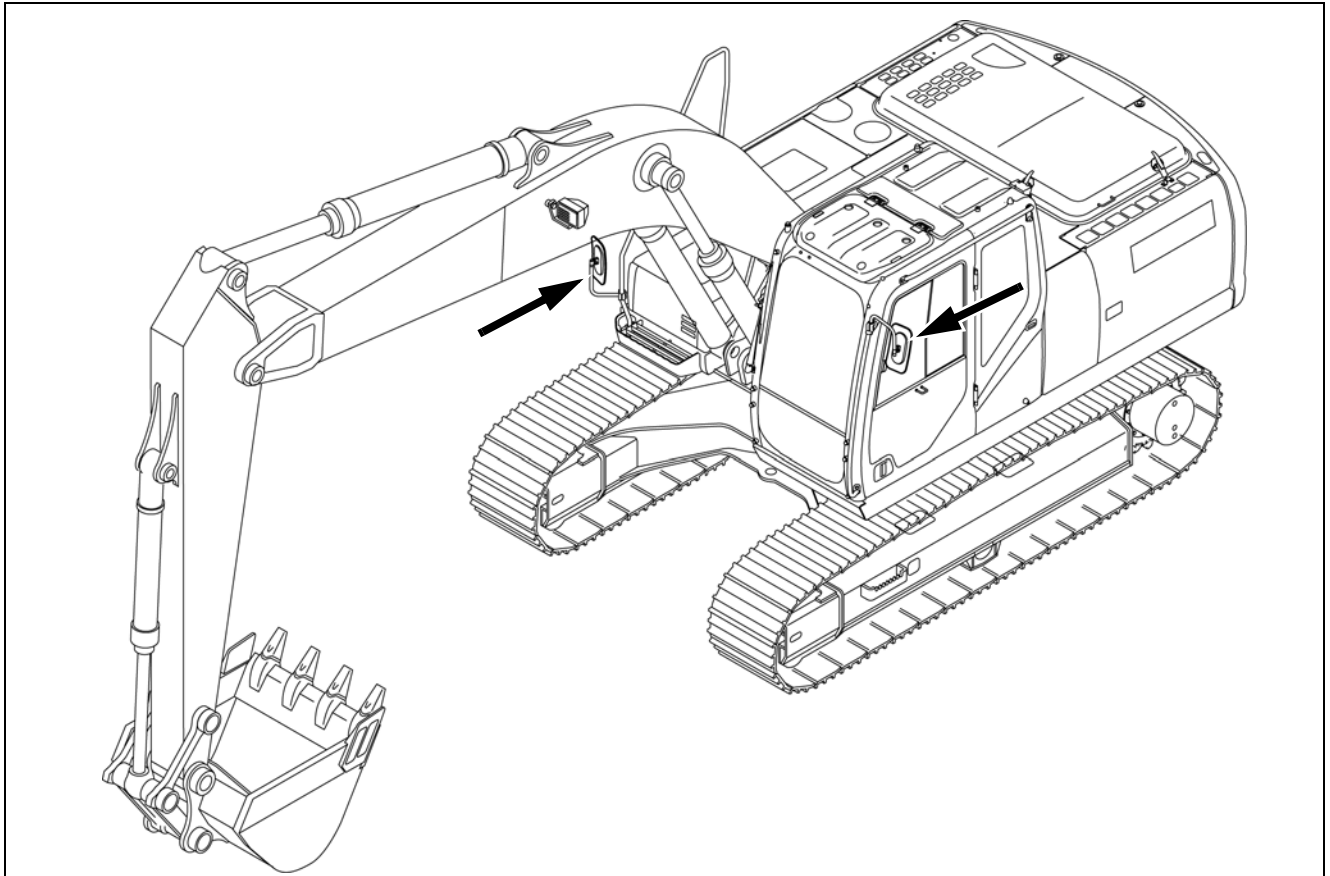

1-0080

Figure 53

### TO INSTALL THE MIRRORS

1. Install the rear view mirror stay (1) to the right front access handle (2) with the two bolts (3).

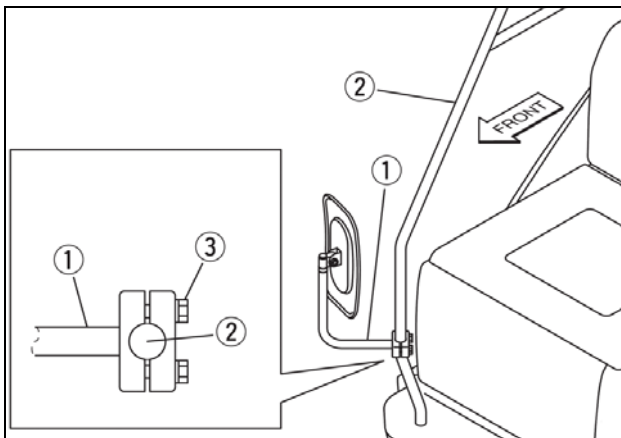

1-0022

Figure 54

2. Loosen the bolt (4) and attach the mirror to the stay(1).

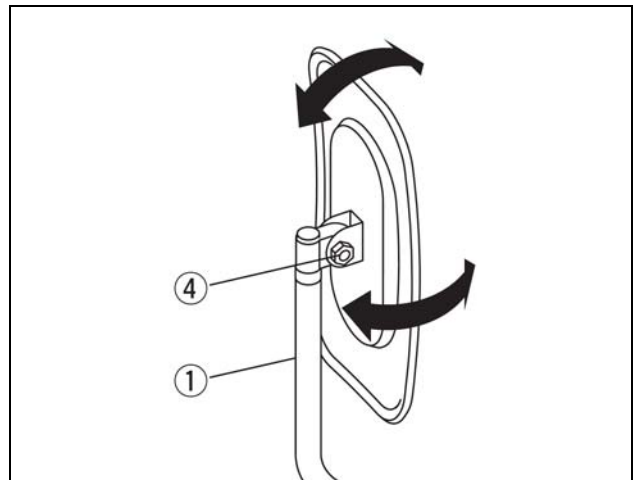

1-0023

Figure 55

**WARNING:** When transporting the machine make sure the mirrors are not protruding from the machine. Fold the mirrors inward to avoid an accident.

## STOPPING THE ENGINE

1. Park the excavator on flat, solid ground and lower the attachment to the ground
2. Turn the engine throttle button to low idle position and let the engine run for 5 minutes.

**IMPORTANT:** *Always let the engine run at idle before switching off completely, except in emergency situations.*



CT02C194

Figure 6

3. Turn the starter switch key to the OFF position then remove it.

**IMPORTANT:** *When the engine is to be shut down for a considerable length of time, see [Parking the Excavator](#) section.*

## IN THE EVENT OF AN EMERGENCY

This switch, located on the left hand control arm, enables the engine to be shut down in case of an emergency or when it is not possible to shut it down using the starter switch key. When the button is pressed the engine shuts down, the audible alarm device sounds, ENGINE STOP is displayed in the monitor, and the button lights up.

To restart the engine, push the button and turn the starter switch key.

**IMPORTANT:** *This switch should only be used in case of an emergency. Do not use it on a day-to-day basis.*



CT02C052

Figure 7

CLICK HERE TO **DOWNLOAD** THE COMPLETE MANUAL

- Thank you very much for reading the preview of the manual.
- You can download the complete manual from: [www.heydownloads.com](http://www.heydownloads.com) by clicking the link below



- Please note: If there is no response to CLICKING the link, please download this PDF first and then click on it.

CLICK HERE TO **DOWNLOAD** THE COMPLETE MANUAL

**TO SELECT AUXILIARY FLOW RATES**

For each of the three auxiliary hydraulic systems available on X2 excavators, a pre-programmed pump setting can be selected to match the output of the attachment. At the upper right hand position of the monitor, an icon will appear to inform the operator which mode and flow setting has been selected - see Figure 29. If no icon appears on the monitor, the auxiliary pump setting is not activated and the machine will default to a low pump output to protect the attachment. To select a pump output setting, repeatedly press the switch of the indicated mode (breaker or crusher) until the desired flow setting appears on the monitor. Repeatedly pressing the switch will advance through the settings and eventually turn the system ON/OFF.

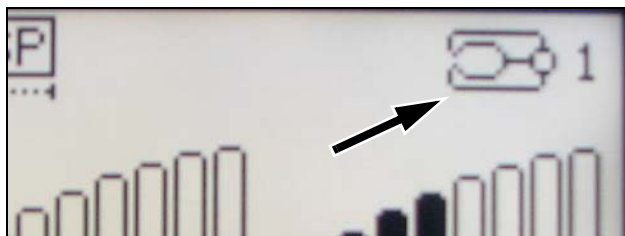

LBX069 Figure 29

When auxiliary hydraulics are activated, an icon appears on the monitor. In Figure 29, Crusher Mode and the #1 pump setting are displayed.

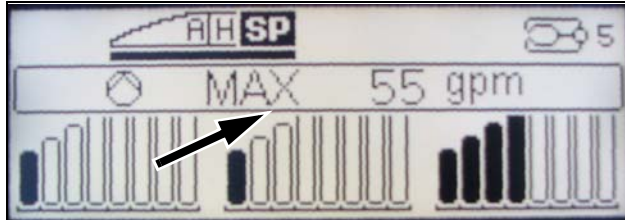
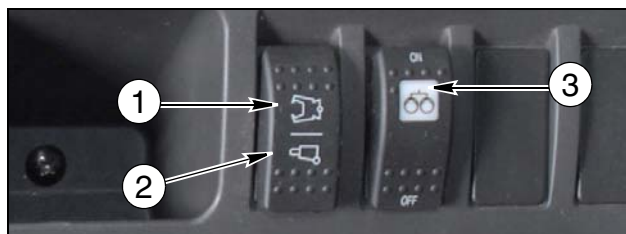

Figure 30

In Figure 30, Crusher Mode and the #5 pump setting are activated - 1-pump flow at 55 gpm is also shown.

Maximum auxiliary pump output achieved in SP mode at full engine RPM. Lowering engine RPMs will affect pump output.



LBX008 Figure 31

Selecting Crusher Mode (1) in Figure 31, sets double-acting flow for open/close; Breaker Mode (2) sets single-acting flow. Repeatedly pressing either of the icons on this switch changes the pump output setting.

Selecting 2-Pump Flow (3) in Figure 31, ON/OFF enables 1-pump or 2-pump flow. Five pump settings for each mode (breaker or crusher) at 1-pump/2-pump flow provides a total of 10 pre-programmed pump settings.

If breaker mode (2) is selected and 2-pump flow is activated, a warning message "SWITCH TO 1-PUMP" will be displayed on the monitor.

If excavator is equipped with Single-Acting Hydraulics, the machine will not come equipped with a 2-pump switch (3) in Figure 31.

## Chapter 5 LUBRICATION, FILTERS, AND FLUIDS

### TABLE OF CONTENTS

|   |      |
|---|------|
| Service Instructions .....                              | 5-3  |
| Daily Inspections .....                                 | 5-4  |
| Hourmeter .....   | 5-4  |
| Lubrication Chart .....                                 | 5-5  |
| Fluids and Lubricants .....                             | 5-6  |
| Engine Oil .....  | 5-6  |
| Fuel .....  | 5-6  |
| Coolant Solution .....                                  | 5-7  |
| Environment .....                                       | 5-7  |
| Fluid and Lubricant Capacities and Specifications ..... | 5-8  |
| Lubrication Points .....                                | 5-9  |
| Boom / Arm / Bucket Lubrication .....                   | 5-9  |
| Excavator Lubrication Points .....                      | 5-10 |
| Greasing the Swing Reduction Gear .....                 | 5-11 |
| Greasing the Turntable Teeth .....                      | 5-11 |
| Fluid Levels .....                                      | 5-12 |
| Engines .....   | 5-13 |
| Service Specifications .....                            | 5-13 |
| Level .....   | 5-13 |
| Draining, Replacing the Oil Filter, and Filling .....   | 5-13 |
| Cooling System .....                                    | 5-15 |
| Service Specifications .....                            | 5-15 |
| Coolant Solution .....                                  | 5-15 |
| Level .....   | 5-15 |
| Draining .....  | 5-15 |
| Rinsing .....   | 5-16 |
| Filling .....   | 5-16 |
| Fuel System .....                                       | 5-17 |
| Service Specifications .....                            | 5-17 |
| Fuel System Components .....                            | 5-17 |
| Fuel System Air Bleed .....                             | 5-17 |
| Draining the Fuel Tank .....                            | 5-18 |
| Fuel Pre-filter Components .....                        | 5-19 |
| Draining Water From the Fuel Pre-filter .....           | 5-19 |
| Replacing the Fuel Pre-filter .....                     | 5-19 |
| Fuel Main Filter Components .....                       | 5-20 |
| Draining Water From the Fuel Main Filter .....          | 5-20 |
| Replacing the Fuel Main Filter .....                    | 5-20 |
| Filling the Fuel Tank .....                             | 5-21 |
| Electronic Fuel Transfer Pump Components .....          | 5-21 |
| Cleaning the Electronic Fuel Transfer Pump .....        | 5-21 |
| Releasing Pressure in the Hydraulic System .....        | 5-22 |
| Hydraulic System .....                                  | 5-23 |
| Service Specifications .....                            | 5-23 |
| Level in the Reservoir .....                            | 5-24 |
| Filling the Hydraulic Reservoir .....                   | 5-24 |
| Pilot Filter Replacement .....                          | 5-25 |
| Replacing the Reservoir Breather .....                  | 5-25 |
| Return Filter Replacement .....                         | 5-26 |
| Cleaning and Replacement of the Suction Filter .....    | 5-26 |
| Replacing the Hydraulic Fluid .....                     | 5-27 |
| Bleeding Air from the Hydraulic Components .....        | 5-28 |

### GREASING THE SWING REDUCTION GEAR

Every 5000 hours, loosen the air bleed plug (1) and insert grease into the grease fitting (2) until the grease comes out of the air bleed plug (1).

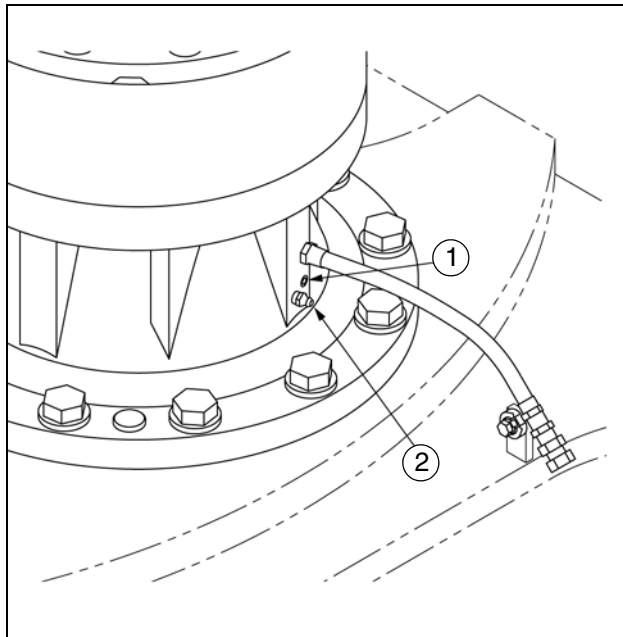

### GREASING THE TURNTABLE TEETH

Every 500 hours, remove the bolts (1) that hold the tool box to the frame (2), remove the second plate (3) and the 2 screws (4), check for damage on the gear teeth and also the general condition of the gear teeth.

If the gear surface is not well greased, add grease.

If the grease is white due to moisture content, etc. replace it with new grease.

If water accumulation is found:

1. Remove the protective panel from the lower central area.
2. Remove the plug.
3. Discharge the water or contaminated grease.
4. Install the plug.
5. Insert new grease through the port, then install the plate (3) and tool box (2).

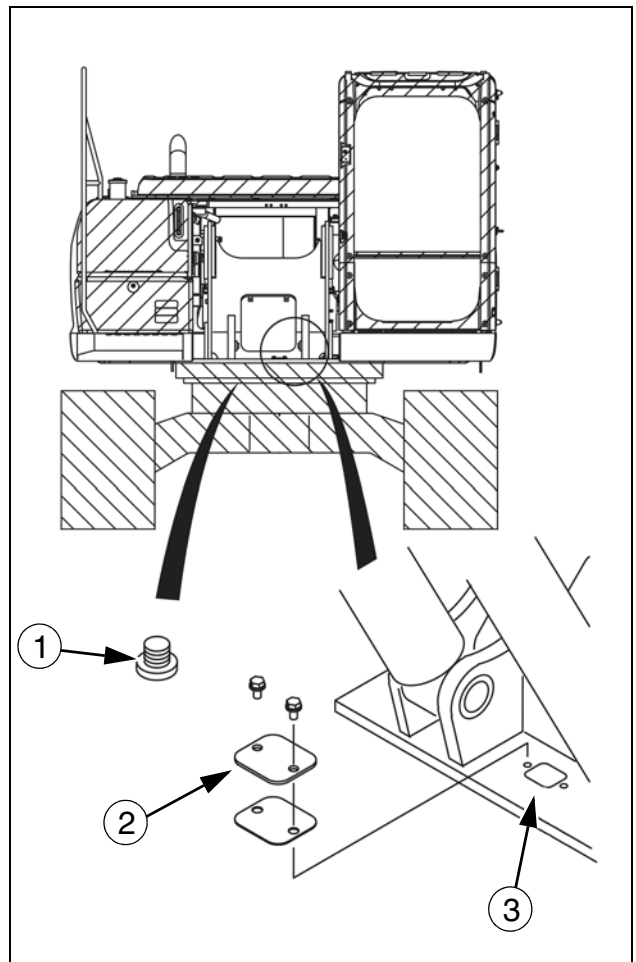

Figure 10

**FILLING THE FUEL TANK**

1. Clean carefully around the filling cap (1). Remove the cap.
2. Fill the tank, make sure that no water or dust enters the tank.

**IMPORTANT:** *Never remove the tank strainer (2) for filling.*

**WARNING:** *Never refuel when the engine is running. Never smoke when refueling.*

**IMPORTANT:** *In cold weather, use fuel corresponding to the ambient temperature. See Lubrication and Fluids section. Fill the fuel tank after each working day to prevent the formation of condensation.*

3. Install the filler cap.

**IMPORTANT:** *Make sure that the cap is correctly locked.*

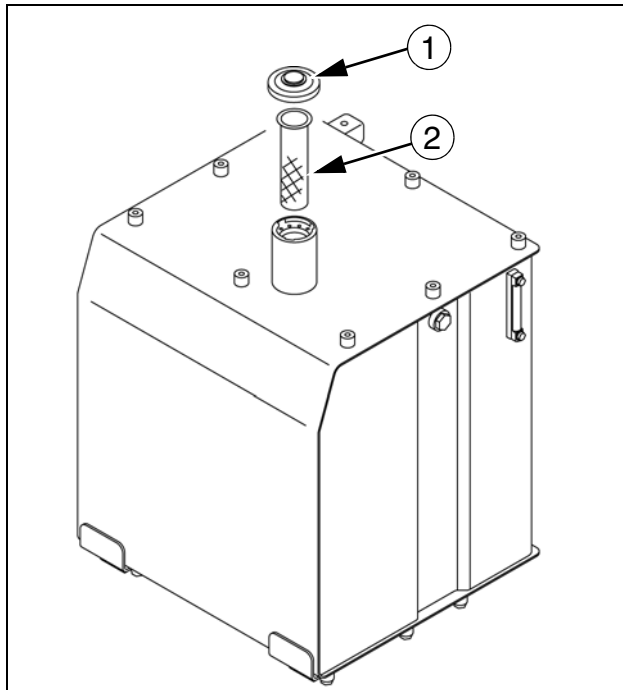

3-0012

Figure 34

**ELECTRONIC FUEL TRANSFER PUMP COMPONENTS**

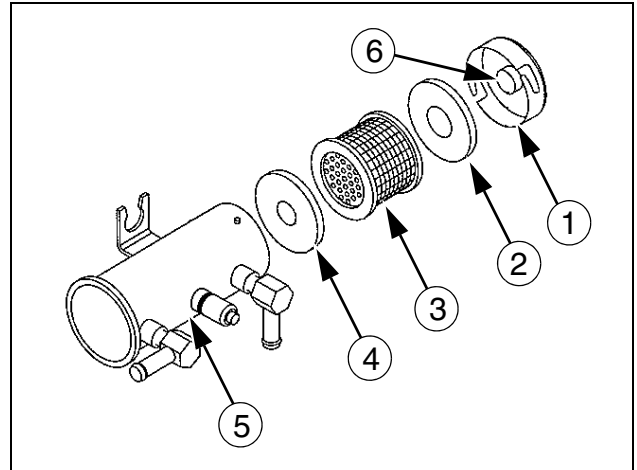

Figure 35

1. Cover
2. Gasket
3. Filter
4. Gasket
5. Body
6. Magnet

The electronic fuel transfer pump has a metal screen to catch any impurities in the fuel. Proper care of the electronic fuel transfer pump improves performance of the excavator.

**CLEANING THE ELECTRONIC FUEL TRANSFER PUMP**

1. Turn the cover (1) counterclockwise.
2. Remove the larger gasket (2), filter (3) and smaller gasket (4).
3. Inspect the filter for any damage to the mesh. If it is damaged replace the filter. To clean it use clean diesel fuel or compressed air.
4. Clean the cover (1), magnet (6), and the body (5).
5. Replace the gaskets (2 + 4),
6. Instal the small gasket (4) in the body (5), then the filter (3), and lastly the large gasket (2).
7. Install the cover (6) clockwise.

2. Remove the outer element.



LBX086

Figure 51

3. Remove the inner element if it needs replacing.

**IMPORTANT:** *The inner element must be replaced, not cleaned.*



LBX085

Figure 52

4. Insert the new inner element. Wipe down the sides of the air cleaner

**IMPORTANT:** *Do not let any dust or debris get in the air line when you replace the inner element.*

5. Install the outer element.

6. Install the cover with the dust port at the bottom.

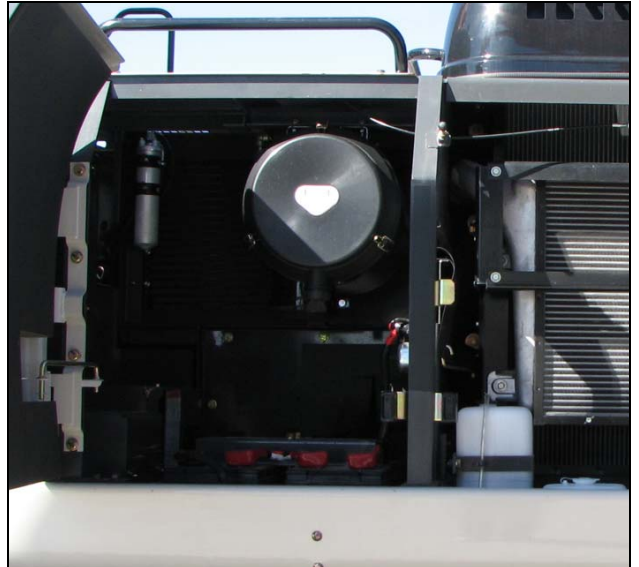

Figure 53

7. Check the dust port to make sure it is not clogged up and working properly.

## FAN AND ALTERNATOR DRIVE BELT

### MAINTENANCE SPECIFICATIONS

Visual check ..... Every 10 hours or every day  
 Check belt tension ..... Every 250 hours

### CHECKING THE TENSION

Use your finger to exert pressure of around 20 lbs on the center of the drive belt. The tension slack should be between about 1/2".

**NOTE:** Check if there are any signs of wear damage to the pulleys or the belt. Check carefully to ensure that the belt is correctly positioned in the pulley grooves. If the belt is stretched, cracked or frayed, it must be replaced.

**IMPORTANT:** If the engine runs with the belt slack, the belt can slip in its housing and cause the engine to overheat or the battery to receive insufficient charge.

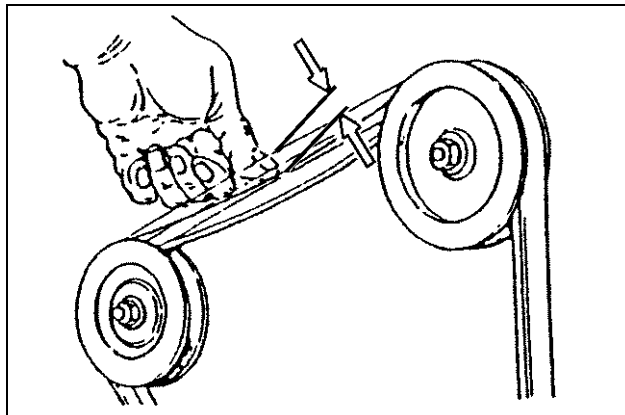

CS98M560

Figure 10

### ADJUSTING THE TENSION

Loosen the upper and lower bolts (1). Use the adjustment screws (2) to move the alternator outwards until belt tension is correct. Tighten the alternator mounting bolts (1).

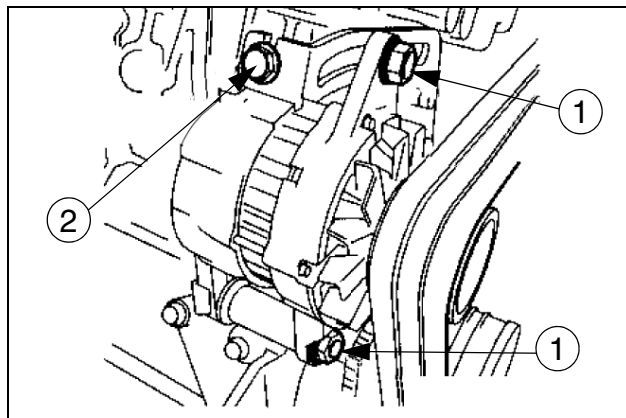

Figure 11

### REPLACING THE BELT

If a belt breaks, the battery load indicator lights up on the instrument panel. Shut down the engine, remove the starter switch key and change the belt.

1. Remove the mounting bolts (1). Use the adjustment screw (2) to push the alternator inward.
2. Remove the belt that is worn out.
3. Install the new belt.
4. Adjust the belt using the screw (2).
5. Tighten the mounting bolts (1).
6. Run the engine for about an hour and then check the belt tension again.

## FUSES

**IMPORTANT:** Before changing fuses or relays, turn the starter key switch to the Shut down position.

**IMPORTANT:** Never replace a fuse with a fuse of a different amperage.

The fuse box is located in the operator's compartment at the back on the left-hand side.

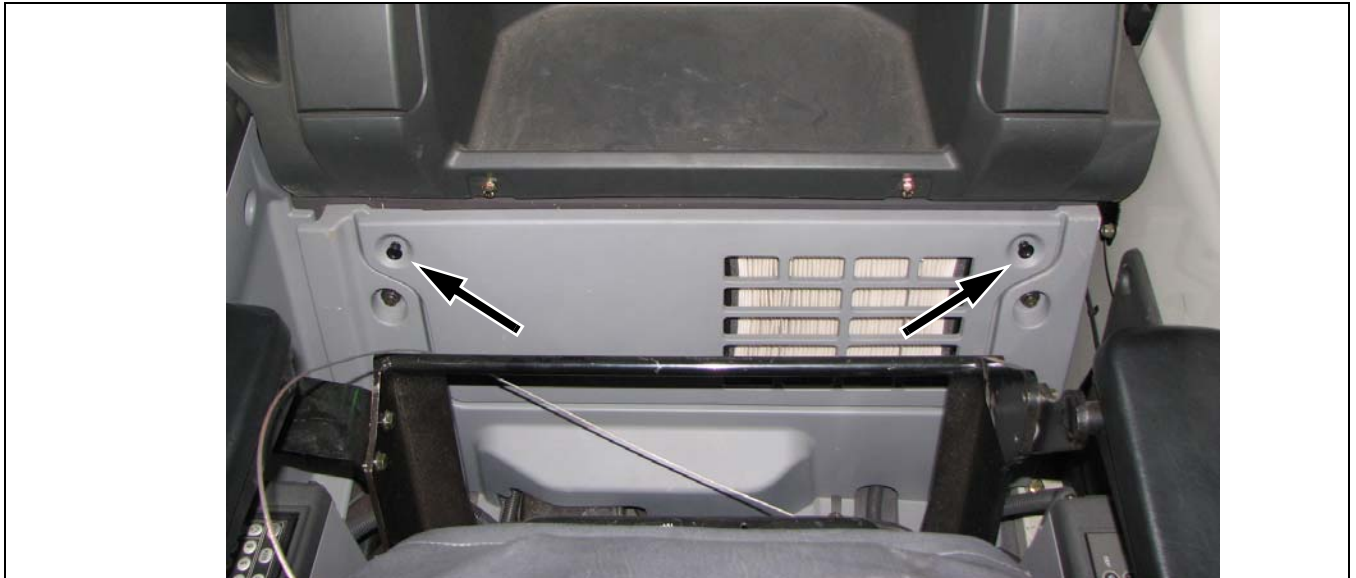

Figure 1

To access the fuses, remove the cover of the box.

A notice on the cover gives the function and amperage of each fuse.

**NOTE:** To remove and install a fuse, use the plastic pliers located inside the box.

**NOTE:** Two spare fuses (10 amp and 20 amp) are to be found on the inside of the cover.

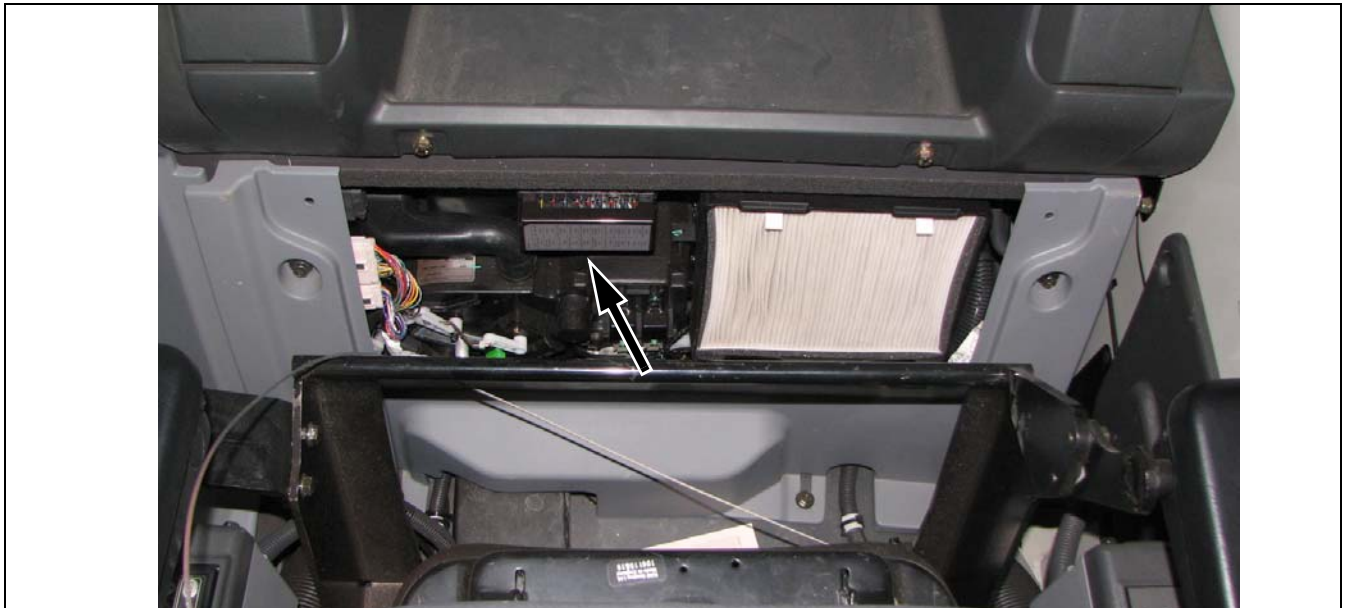

Figure 2

**EXCAVATOR OVERALL DIMENSIONS**

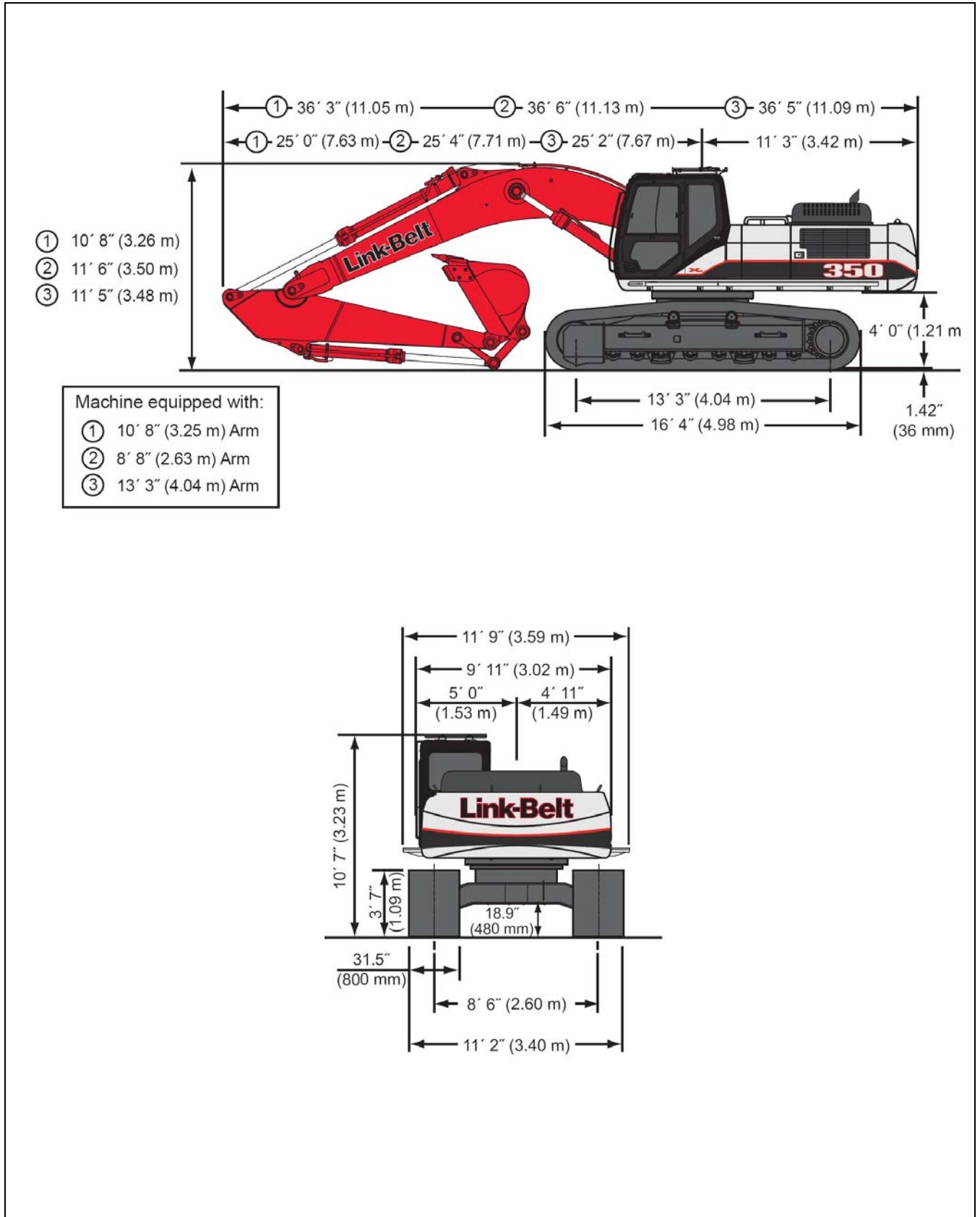

Figure 1

CLICK HERE TO **DOWNLOAD** THE COMPLETE MANUAL

- Thank you very much for reading the preview of the manual.
- You can download the complete manual from: [www.heydownloads.com](http://www.heydownloads.com) by clicking the link below



- Please note: If there is no response to CLICKING the link, please download this PDF first and then click on it.

CLICK HERE TO **DOWNLOAD** THE COMPLETE MANUAL