

en

Operator's manual

Hydraulic excavator

Document ID

	ORIGINAL OPERATOR'S MANUAL
Order number:	11821224
Issued:	2019-06-20
Version:	01
Author:	LFR / Technical Documentation Department

Product ID

Manufacturer:	Liebherr-France SAS
Type:	R 956
Type no.:	1476, 1728 (USA / CAN)
From Serial no.:	39634

Contact

Liebherr-France SAS
2 avenue Joseph Rey, B.P. 90287
F – 68005 Colmar Cedex

CLICK HERE TO **DOWNLOAD** THE COMPLETE MANUAL

- Thank you very much for reading the preview of the manual.
- You can download the complete manual from: www.heydownloads.com by clicking the link below



- Please note: If there is no response to CLICKING the link, please download this PDF first and then click on it.

CLICK HERE TO **DOWNLOAD** THE COMPLETE MANUAL

3.3.12	Sun blind	122
3.3.13	Side windows	123
3.3.14	Viewing devices	124
3.3.15	Lighting	131
3.3.16	Cab lighting system	132
3.3.17	Windscreen wipers	133
3.3.18	Auxiliary heater (option)	133
3.4	Operation	135
3.4.1	Inspection tour before putting into service	135
3.4.2	Refuelling	136
3.4.3	Refuelling with the electric refuelling pump (option)	137
3.4.4	Refuelling diesel exhaust fluid	139
3.4.5	Immobiliser (option)	140
3.4.6	Preparing machine for dust intensive application	141
3.4.7	Preparing machine for use in biologically sensitive areas	141
3.4.8	Starting diesel engine	142
3.4.9	Bringing machine to operating temperature	143
3.4.10	Engine speed and operating mode	143
3.4.11	After starting	144
3.4.12	Sensor-controlled low idle automatic	145
3.4.13	Automatic engine shut-off after idling (option)	147
3.4.14	Shutting off diesel engine	147
3.4.15	Travelling and braking	149
3.4.16	Travel alarm (option)	152
3.4.17	Controlling working attachment	152
3.4.18	Turning and braking uppercarriage	155
3.4.19	Turning alarm (option)	157
3.4.20	Float position of bottom dump shovel attachment	158
3.4.21	Hoist cylinder protection (option)	161
3.4.22	Stick cylinder protection	163
3.4.23	Controlling special working attachment without mini-joystick (option)	164
3.4.24	Controlling special working attachment with mini-joystick (option)	167
3.4.25	Control changeover (option)	170
3.4.26	Changing over control of right mini-joystick (option)	172
3.4.27	Changing over control of left double pedal (option)	174

1.2 Technical data

1.2.1 Vibration emission

Description	Unit	Value
Hand/arm vibrations	m/s ²	≤ 2.5
Whole-body vibrations	m/s ²	≤ 0.5

Tab. 1: Vibration emission

Operator's seat

- The operator's seat built into this machine by the manufacturer conforms to ISO 7096:2000, EM 6.

Hand/arm vibrations

- If the machine is operated as intended, the weighted (frequency-weighted) effective value of the hand/arm vibrations in accordance with ISO 5349- 1:2001 is less than 8.2 ft/s².

Whole-body vibrations

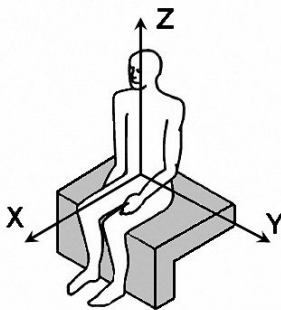

- This value conforms to the details of technical report ISO/TR 25398:2006.
- The measuring inaccuracy is defined in standard EN 12096:1997.
- As the specified values are individual effective values for specific typical application areas, only a limited assessment of the load imposed on the operator by whole-body vibrations is possible.
- In order to accurately assess the daily exposure of an operator in the course of an 8-hour working day, use the Liebherr brochure concerning whole-body vibrations as well as the specially written software.
- Both documents are available from Liebherr dealers and are provided with every new machine on a documentation CD (Liebherr-Parts).

1.2.2 Sound level

The guaranteed sound power level (L_{WA}) is measured according to Directive 2000/14/EC.

The sound pressure level (L_{pA}) is measured according to standard ISO 6396. The measuring inaccuracy is defined in this standard.

Designation	Unit	Value
Sound power level (L_{WA}) outside	dB(A)	106
Sound pressure level (L_{pA}) in operator's cab	dB(A)	72

Tab. 2: Sound level



Operator's Cab

Cab	Work headlights integrated in the ceiling, a door with a sliding window (can be opened on both sides), large storing box and several stowing possibilities, shock-absorbing suspension, sounddamping insulating, tinted laminated safety glass, separate window shades for the sunroof window and windscreen, cigarette lighter and 12 V plug, storage bins, lunchbox, cup holder
Operator's seat	Liebherr-Comfort seat, airsprung with automatic weight adjustment, vertical and longitudinal seat damping including consoles and joysticks. Seat and armrests adjustable separately and in combination, seat heating as standard
Control system	Arm consoles, swinging with the seat
Operation and displays	Large high-resolution color display with intuitive operation via touchscreen, video, versatile adjusting, control and monitoring facilities, e.g. climate control, implement and attachment parameters
Air-conditioning	Standard automatic air-conditioning fully controlled on the display, ambient air function, fast de-icing and demisting at the press of a button, air vents can be operated via a menu. Ambient air and fresh air filters can be easily replaced and are accessible from outside and standing on the ground. Heating-cooling unit, designed for extreme outside temperatures, sensors for solar radiation, inside and outside temperatures



Undercarriage

Versions	
LC-V	Gauge 2,890 mm / 9'6"
HD	Gauge 2,900 mm / 9'6"
Drive	Liebherr swashplate motor with integrated brake valve
Transmission	Liebherr compact planetary reduction gear
Maximum travel speed	Low range 2.6 km/h / 1.6 mph High range 3.7 km/h / 2.3 mph
Net drawbar pull on crawler	446 kN / 100,265 lbf
Track components	D8L, maintenance-free
Track rollers/Carrier rollers	LC-V: 10/3 HD: 9/2
Tracks	Sealed and greased
Track pads	Triple grouser
Holding brake	Wet multi-disc (spring applied, pressure released)
Brake valves	Integrated into travel motor
Lashing eyes	Integrated



Equipment

Type	Combination of resistant steel plates and cast steel components
Hydraulic cylinders	Liebherr cylinders with seal and guidance systems
Bearings	Sealed, low maintenance
Lubrication	Automatic central lubrication system (except link and tilt geometry)
Hydraulic connections	Pipes and hoses equipped with SAE split-flange connections
Buckets	Standard equipped with Liebherr tooth system

Buckets Machine stability per ISO 10567* (75% of tipping capacity)

				LC-V-Undercarriage (with track pads 600 mm/24")		
	Cutting width	Capacity ISO 7451	Weight	Stick length (m/ft in)		
				2.90 9'6"	3.80 12'6"	5.00 16'5"
with counterweight 11.0 t/24,250 lb						
STD ¹⁾	1,350 53"	1.65 2.16	2,100 4,630	▲	▲	-
	1,550 61"	2.00 2.62	2,250 4,960	■	■	-
	1,750 69"	2.35 3.07	2,450 5,400	■	△	-
	1,950 77"	2.70 3.53	2,650 5,840	△	-	-
STD ²⁾	1,200 47"	1.25 1.63	1,300 2,870	-	-	▲
	1,350 53"	1.50 1.96	1,400 3,090	-	-	▲
	1,500 59"	1.75 2.29	1,500 3,310	-	-	■
	1,650 65"	2.00 2.62	1,600 3,530	-	-	■
with counterweight 12.0 t/26,460 lb						
STD ¹⁾	1,350 53"	1.65 2.16	2,100 4,630	▲	▲	-
	1,550 61"	2.00 2.62	2,250 4,960	▲	▲	-
	1,750 69"	2.35 3.07	2,450 5,400	▲	△	-
	1,950 77"	2.70 3.53	2,650 5,840	△	△	-
	1,950 77"	3.00 3.92	2,750 6,060	△	-	-
STD ²⁾	1,200 47"	1.25 1.63	1,300 2,870	-	-	▲
	1,350 53"	1.50 1.96	1,400 3,090	-	-	▲
	1,500 59"	1.75 2.29	1,500 3,310	-	-	■
	1,650 65"	2.00 2.62	1,600 3,530	-	-	■

* Indicated loads are based on ISO 10567, at maximum reach, and may be swung 360° on firm and even ground

¹⁾ Standard bucket with Liebherr teeth Z 70 (appropriate for materials up to classification 5, according to VOB, Section C, DIN 18300)

²⁾ Standard bucket from R 946 Litronic[®] with Liebherr teeth Z 50 (appropriate for materials up to classification 5, according to VOB, Section C, DIN 18300)

Other buckets available upon request

Max. material weight ▲ = ≤ 2.0 t/m³/3,400 lb/yd³, ■ = ≤ 1.8 t/m³/3,000 lb/yd³, ▲ = ≤ 1.65 t/m³/2,800 lb/yd³, ■ = ≤ 1.5 t/m³/2,500 lb/yd³, △ = ≤ 1.2 t/m³/2,000 lb/yd³, - = not authorized

Lift Capacities

with Mono Boom Straight 8.00 m / 26'3", Removable Counterweight 12.0 t / 26,460 lb and Track Pads 750 mm / 30"

Stick 2.35 m / 7'9"

Under-carriage	↕	4.5 m 15 ft		6.0 m 20 ft		7.5 m 25 ft		9.0 m 30 ft		10.5 m 35 ft		12.0 m 40 ft		m ft in
		↕	↕	↕	↕	↕	↕	↕	↕	↕	↕	↕	↕	
12.0 m t														
40 ft lb														
10.5 m t			15.0*	15.0*								11.9*	11.9*	6.6
35 ft lb			33,2*	33,2*								27,0*	27,0*	20'10"
9.0 m t			14.7*	14.7*	12.8*	12.8*						10.2*	10.2*	8.2
30 ft lb			32,1*	32,1*	28,0*	28,0*						22,7*	22,7*	26'6"
7.5 m t	20.0*	20.0*	15.4*	15.4*	12.9*	12.9*	10.0	11.3*				9.4*	9.4*	9.3
25 ft lb	42,9*	42,9*	33,4*	33,4*	28,0*	28,0*	21,4	24,8*				20,8*	20,8*	30'2"
6.0 m t			16.7*	16.7*	12.9	13.4*	9.8	11.4*				8.2	9.0*	10.0
20 ft lb			35,9*	35,9*	27,8	29,0*	21,1	24,7*				18,3	19,8*	32'8"
4.5 m t					12.2	13.9*	9.5	11.5*				7.6	8.8*	10.5
15 ft lb					35,3	38,7*	26,4	30,1*	20,5	25,0*		16,7	19,5*	34'4"
3.0 m t					11.6	14.1*	9.1	11.6*				7.2	8.9*	10.7
10 ft lb					25,1	30,6*	19,8	25,1*	16,0	20,5*		16,0	19,6*	35'
1.5 m t					11.3	13.8*	8.9	11.3*	7.3	9.2*		7.2	8.8*	10.7
5 ft lb					24,3	30,0*	19,2	24,5*	15,8	19,5*		15,8	19,5*	35'
0 m t					11.1	12.9*	8.8	10.6*				7.4	8.2*	10.5
0 ft lb			29,4*	29,4*	24,0	27,9*	19,0	22,9*				16,2	18,0*	34'4"
-1.5 m t					12.5*	12.5*	11.2	11.3*	8.8	9.3*		7.3*	7.3*	10.0
-5 ft lb					27,5*	27,5*	24,1	24,5*	19,1	19,9*		16,0*	16,0*	32'8"
-3.0 m t					9.9*	9.9*	9.0*	9.0*	6.7*	6.7*		5.9*	5.9*	9.2
-10 ft lb					21,5*	21,5*	19,3*	19,3*	13,5*	13,5*		13,0*	13,0*	30'2"
-4.5 m t														
-15 ft lb														

Stick 2.90 m / 9'6"

Under-carriage	↕	4.5 m 15 ft		6.0 m 20 ft		7.5 m 25 ft		9.0 m 30 ft		10.5 m 35 ft		12.0 m 40 ft		m ft in
		↕	↕	↕	↕	↕	↕	↕	↕	↕	↕	↕	↕	
12.0 m t														
40 ft lb														
10.5 m t			31.0*	31.0*										11.7*
35 ft lb			70,3*	70,3*										27,3*
9.0 m t					14.0*	14.0*								8.9*
30 ft lb					30,8*	30,8*								20,1*
7.5 m t	15.3*	15.3*	14.7*	14.7*	12.4*	12.4*	10.1	10.9*						7.8*
25 ft lb	32,7*	32,7*	31,8*	31,8*	26,9*	26,9*	21,7	23,7*						17,4*
6.0 m t			16.0*	16.0*	12.9*	12.9*	9.9	11.0*	7.7	8.6*				17,4*
20 ft lb			34,5*	34,5*	28,0*	28,0*	21,3	24,0*						17,4*
4.5 m t			16.7	17.4*	12.3	13.6*	9.5	11.3*	7.5	9.7*				7.8*
15 ft lb			36,2	37,5*	26,7	29,4*	20,5	24,5*	16,2	21,0*				15,1*
3.0 m t					11.7	14.0*	9.1	11.4*	7.4	9.6*				15,1*
10 ft lb					33,8	37,7*	25,3	30,3*	19,8	24,8*	15,9	20,8*		14,7
1.5 m t					11.3	13.9*	8.9	11.3*	7.2	9.4*				15,2*
5 ft lb					28,1*	28,1*	24,3	30,1*	19,1	24,5*	15,6	20,1*		14,6
0 m t			15.0	15.4*	11.0	13.2*	8.7	10.8*	7.1	8.7*				14,6
0 ft lb			32,4	34,5*	23,9	28,6*	18,8	23,4*	15,4	18,5*				14,9
-1.5 m t					13.8*	13.8*	11.0	11.9*	8.7	9.7*	7.2*			7,0*
-5 ft lb					30,2*	30,2*	23,8	25,7*	18,8	20,9*				15,4*
-3.0 m t					11.2*	11.2*	9.8*	9.8*	7.8*	7.8*				15,4*
-10 ft lb					24,5*	24,5*	21,2*	21,2*	16,5*	16,5*				12,9*
-4.5 m t					7.8*	7.8*	6.7*	6.7*						12,9*
-15 ft lb														11,5*

Stick 3.80 m / 12'6"

Under-carriage	↕	4.5 m 15 ft		6.0 m 20 ft		7.5 m 25 ft		9.0 m 30 ft		10.5 m 35 ft		12.0 m 40 ft		m ft in
		↕	↕	↕	↕	↕	↕	↕	↕	↕	↕	↕	↕	
12.0 m t														
40 ft lb														
10.5 m t														
35 ft lb														
9.0 m t														
30 ft lb														
7.5 m t														
25 ft lb														
6.0 m t	18.0*	18.0*	14.7*	14.7*	12.2*	12.2*	10.1	10.5*	7.8	9.3*				
20 ft lb	35,3*	35,3*	31,1*	31,1*	26,4*	26,4*	21,7	22,8*	16,8	20,2*				
4.5 m t			16.4*	16.4*	12.7	13.0*	9.7	10.9*	7.6	9.4*				
15 ft lb			35,5*	35,5*	27,3	28,1*	20,8	23,6*	16,4	20,4*				
3.0 m t			16.2	17.7*	12.0	13.6*	9.3	11.2*	7.4	9.5*	6.0	6.3*		
10 ft lb			35,0	38,2*	25,8	29,5*	20,0	24,3*	15,9	20,6*	10,7*	10,7*	39'8"	
1.5 m t			15.3	17.9*	11.4	13.9*	8.9	11.3*	7.2	9.4*	5.9	6.4*		
5 ft lb			33,1	38,7*	24,6	30,1*	19,2	24,5*	15,5	20,4*	11,5*	11,5*	39'	
0 m t			15.0	17.0*	11.1	13.6*	8.7	11.0*	7.0	9.1*				
0 ft lb			32,3	37,0*	23,9	29,4*	18,7	23,9*	15,2	19,6*				
-1.5 m t	9.9*	9.9*	14.9	15.5*	10.9	12.7*	8.6	10.3*	7.0	8.3*				
-5 ft lb	22,9*	22,9*	32,2	33,6*	23,6	27,4*	18,5	22,3*	15,1	17,7*				
-3.0 m t	14.8*	14.8*	13.2*	13.2*	11.0	11.1*	8.6	9.0*	6.7*	6.7*				
-10 ft lb	32,3*	32,3*	28,7*	28,7*	23,7	23,9*	18,6	19,2*	13,6*	13,6*				
-4.5 m t	10.9*	10.9*	10.2*	10.2*	8.6*	8.6*	6.6*	6.6*						
-15 ft lb	23,6*	23,6*	21,9*	21,9*	18,4*	18,4*	13,8*	13,8*						

↕ Height ↕ Can be slewed through 360° ↕ In longitudinal position of undercarriage Max. reach * Limited by hydr. capacity

The load values are quoted in tons (t) / lb x 1,000 at stick end (without bucket), and may be swung 360° on firm and even ground. Adjacent values are valid for the undercarriage when in the longitudinal position. Capacities are valid for 750 mm / 30" wide track pads. Indicated loads are based on ISO 10567 standard and do not exceed 75% of tipping or 87% of hydraulic capacity (indicated via *). Without bucket cylinder, link and lever the lift capacities will increase by 825 kg / 1,820 lb. Lifting capacity of the excavator is limited by machine stability and hydraulic capacity.

- Exclusively mount and use special working attachments with approval and as per stipulations of manufacturer of basic machine.

**Note**

- ▶ Any other use or use beyond the stated use is improper use.

2.2.3 Foreseeable misuse

Do not use machine in following cases:

- Transport of persons without mounted and functioning safety equipment
- Lifting of persons without mounted and functioning safety equipment
- Work in explosive environment without corresponding and necessary equipment
- Work in contaminated environment without corresponding and necessary equipment
- Sweeping on side (with working attachment)
- Stamping
- Striking
- Lifting loads without suitable means
- Pulling and pushing of vehicles or objects without suitable towing attachments and brakes on machine

**Note**

- ▶ The manufacturer is not liable for damage caused by improper use.

2.2.4 Operating conditions

- Operate machine in an ambient temperature of -4 °F to 104 °F.
- In case of divergent ambient temperatures, contact Liebherr customer service.
- In case of deployments at below 14 °F, adhere to diesel fuel quality .
- In case of deployments at below 14 °F, use preheatings or arctic diesel (for more information on arctic diesel qualities, see table 1 and DIN EN 590).
- Adhere to operating temperatures of diesel fuels.







Permitted diesel fuels as per DIN EN 590	Cloud point	Ambient temperature
Standard winter diesel	19 °F	NaN-50 °F
Arctic class 0	14 °F	NaN-55 °F
Arctic class 1	3 °F	NaN-68 °F

Tab. 6: Operating temperatures of diesel fuels

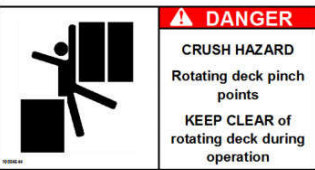
Danger to life

Operation during thunderstorms or storms

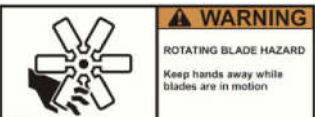
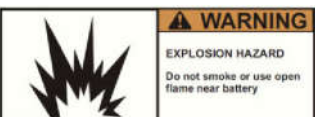
- If possible stop operation before a thunderstorm or storm.
- Put working attachment on the ground in flattest position possible.
- Secure machine correctly.
- Close window.
- Shut off diesel engine.
- Set ignition key to 0.
- Make sure there are no persons in area around machine.

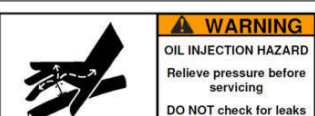
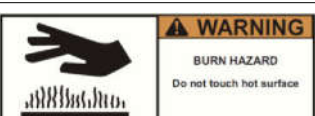
	Sign	Description
1		<p>Danger!</p> <p>Danger of crushing in the slewing area of the uppercarriage. Remaining in danger area is prohibited.</p>
2		<p>Danger!</p> <p>Danger of impact and danger of impaling during machine operation. Remaining in the working area of the machine is prohibited.</p>
3		<p>Lifting prohibited</p> <p>Displayed lifting point is unsuitable for lifting entire machine. Do not lift machine by this lifting point. Adhere to instructions in operator's manual on lifting machine.</p>
4		<p>Prohibited zone</p> <p>Danger of falling. Remaining in the indicated areas is prohibited.</p>
5		<p>Engine shut-off</p> <p>Risk of injury. Exclusively open hood with diesel engine shut off.</p>
6		<p>Risk of explosion</p> <p>Do not smoke. Avoid flames in indicated areas, particularly areas with charging batteries.</p>
7		<p>Risk of electric shock</p> <p>Adhere to a distance of at least 49' 3" ft-in between all parts of working attachment and high voltage cables.</p>
8		<p>Risk of injury</p> <p>Risk of injury from fluids emerging under high pressure.</p>
9		<p>Risk of burns</p> <p>Risk of burns from contact, particularly in area of exhaust silencer.</p>

LFR/11821224/01/2019-06-20/en

- Make sure that everyone is able to operate the fire extinguishers.
- Make sure that everyone knows the local fire alarm possibilities.
- Make sure that everyone knows the local fire-fighting possibilities.
- Before starting machine, unlock all locks of hoods and doors of machine.
- Make sure that check and inspection are performed on time.

2.6.3 Emergency command devices of machine

Depending on equipment, machine has following emergency command devices:

- Emergency stop device
- Emergency cut-off device
- Emergency brake

Danger to life

Defective emergency command devices

- Make sure that all emergency command devices are functioning correctly.
- Regularly check all emergency command devices for function.
- Have defective emergency command devices repaired immediately.

Damage to machine

Incorrect use of emergency command devices

- Exclusively use emergency command devices if there is immediate danger.

2.6.4 Emergency stop function of machine

Damage to diesel engine

Incorrect use of emergency stop equipment

- Exclusively use emergency stop equipment if there is immediate danger.
- If emergency stop equipment has been activated: Let diesel engine run in idle mode for a few minutes after next start.

2.7 Safe operation

2.7.1 Intoxicants

Danger to life

Physical and mental impairment

- Make sure that no persons working on or with the machine are under the influence of drugs.
- Make sure that no persons working on or with the machine are under the influence of alcohol.

2.9 Safe maintenance

2.9.1 Spare parts

Danger to life

Incorrect spare parts

- Use original spare parts.
- Make sure that the spare parts meet the technical requirements specified by the manufacturer.
- After replacing parts, tighten loosened screw connections with prescribed tightening torque.
- Find prescribed tightening torque in supplied documentation.
- If the tightening torque is not prescribed by the supplied documentation: Find prescribed tightening torque in Liebherr factory standard.
- If the tightening torque is not prescribed by the Liebherr factory standard: Find tightening torque in valid DIN standard, EN standard or ISO standard.

2.9.2 Heavy parts

Danger to life

Incorrect handling

- Exclusively use machine for load-lifting with sufficient loading capacity.
- Exclusively use suitable and functioning lifting accessories with sufficient loading capacity.
- Make sure there are no persons underneath raised loads.
- Exclusively task qualified and experienced persons with the attaching of loads.
- Exclusively task qualified and experienced persons with the directing of operators.
- Make sure that the spotter can be seen by the operator.
- Make sure that spotter and operator are in voice contact if necessary.

Injury

Incorrect protective equipment



- Put on gloves when handling wire ropes.

2.9.3 Regular checks

Danger to life











Incorrect performance of checks

- Make sure that safety checks are performed regularly on the machine.
- Make sure that all checks are performed by suitable, competent and authorised persons.
- Adhere to national regulations.

Symbol	Meaning
	Control valve block bleeding completed
	Machine movements locked

Tab. 10: General status symbols

Working attachment and working tools

Symbol	Meaning
	Overload warning
	Overload warning system not available
	Control changeover activated
	Control changeover activated
	Boom adjustment active
	Lateral boom adjustment active
	Hoist cylinder protection bypassed
	Stick cylinder protection bypassed
	Stick cylinder shut-off active
	Hoist cylinder shut-off active

LFR/11821224/01/2019-06-20/en

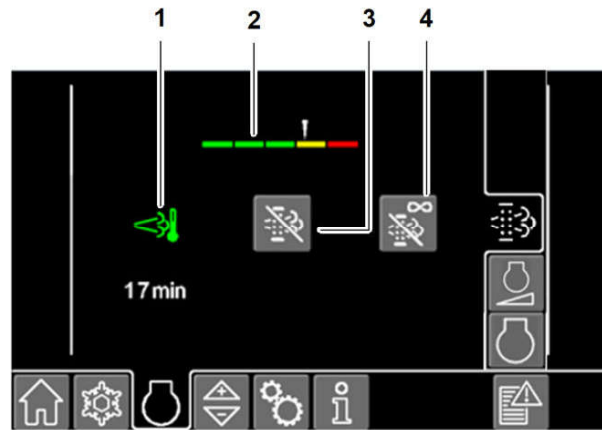

Fig. 153: Diesel particulate filter submenu

- | | | | |
|---|--------------------------------|---|--|
| 1 | Activating regeneration button | 3 | Blocking regeneration button |
| 2 | Contamination level | 4 | Blocking regeneration permanently button |

The regeneration can be activated or blocked depending on contamination level of the diesel particulate filter.

3.2.8 Sensor-controlled low idle automatic and automatic engine stop submenu (option)

Menu call: > > n/min or > > STOP AUTO or >

Access path and display of this submenu vary depending on machine configuration:

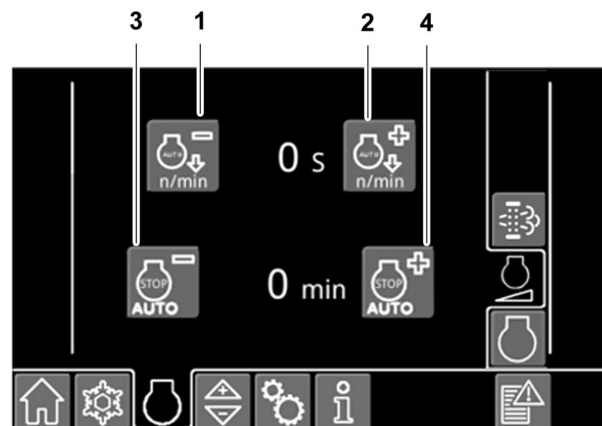

Fig. 154: Sensor-controlled low idle automatic and automatic engine stop submenu

- | | | | |
|---|--|---|---|
| 1 | Reducing activation time for sensor-controlled low idle automatic button | 3 | Reducing idling time until automatic engine stop button |
| 2 | Increasing activation time for sensor-controlled low idle automatic button | 4 | Increasing idling time until automatic engine stop button |

The change of language only takes effect after the system data are stored.

- ▶ Set ignition key to 0.
- ▶ Wait 40 seconds.
- ▶ Set ignition key to 1.
 - ▷ Change of language takes effect.

3.2.21 *Test system* submenu

Menu call:  >  > 

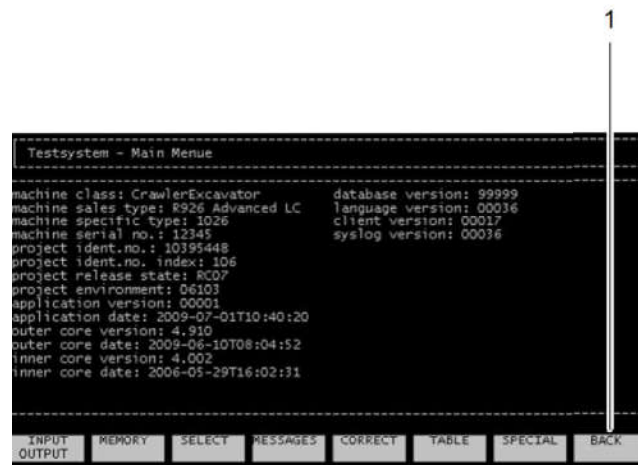

Fig. 184: *Test system* submenu

1 Back button

Various data can be displayed in the *test system* submenu, for example:

- Type and serial number of the machine
- Versions of the various software components
- ▶ Exit *test system* submenu: Press *back* button 1.

3.2.22 *Brightness of LED headlights* submenu (option)

Menu call:  > 

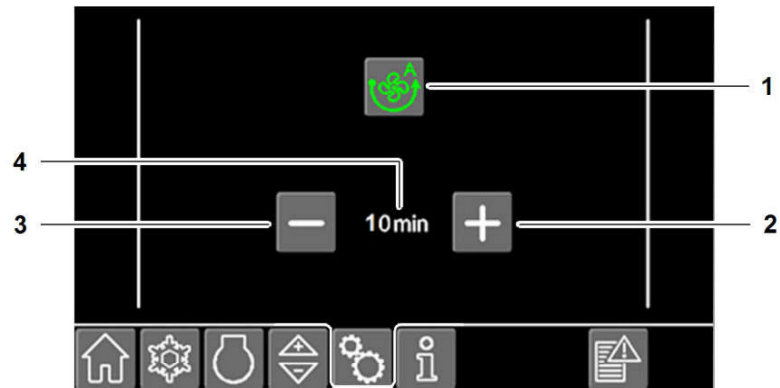

Fig. 223: Automatic reversible fan drive submenu

- | | | | |
|---|---|---|---|
| 1 | Fan button | 3 | Reducing operating interval of fan button |
| 2 | Increasing operating interval of fan button | 4 | Time interval |

► Activate automatic reversible fan drive: (For more information see: [3.4.29 Reversing fan drive for radiator cleaning \(option\), page 176](#))

3.2.31 Priority between lifting boom and turning uppercarriage submenu

Menu call:  > 

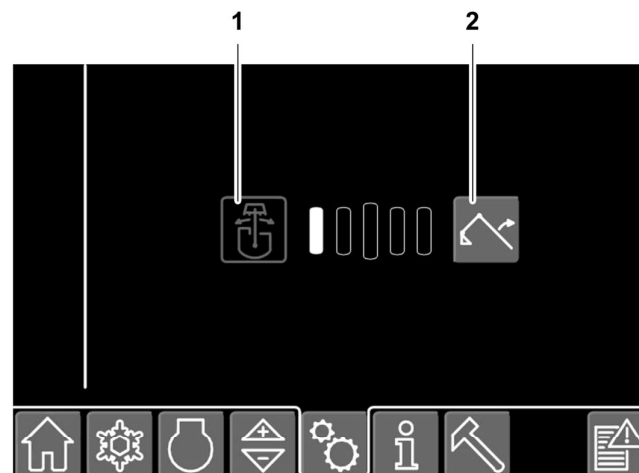

Fig. 224: Priority between lifting boom and turning uppercarriage submenu

- | | | | |
|---|--|---|---|
| 1 | Increasing priority for turning uppercarriage button | 2 | Increasing priority for lifting boom button |
|---|--|---|---|

3.2.32 Information menu

Menu call: 

3.3.4 Fire extinguisher (option)

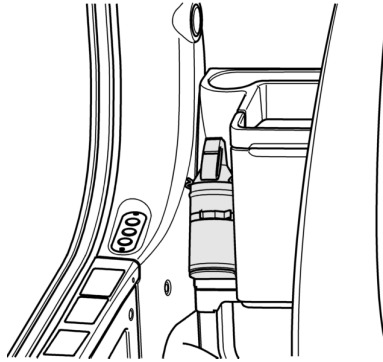

Fig. 257: Fire extinguisher

The fire extinguisher is in the operator's cab.

- ▶ Have fire extinguisher inspected according to the regulations in force where the machine is used.
- ▶ Observe operating instructions on fire extinguisher.



Note

The operator is responsible for installing the fire extinguisher.

- ▶ Observe regulations in force where machine is used.
- ▶ Estimate requirement in relation to operational conditions.
- ▶ Order fire extinguisher and holder: Contact Liebherr customer service.

3.3.5 Safety lever

The safety lever:

- interrupts all hydraulic functions,
- makes it possible to avoid all unintentional movements of the machine.

The engine can only be started when the safety lever is in the upper position.

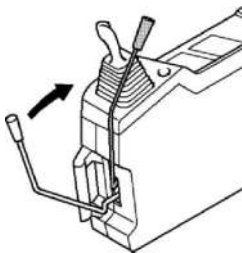

Before starting work:

- ▶ Sit in the operator seat.
- ▶ Start the engine.
- ▶ Move the safety lever to the down position.
 - ▷ The joysticks and the pedals are working.
 - ▷ The slewing gear break returns to its previous state.

Before you stand up:

- ▶ Move the safety lever to the upper position.
 - ▷ The joysticks and the pedals are not working any more.
 - ▷ The slewing gear brake is activated and locked.

3.3.9 Horn

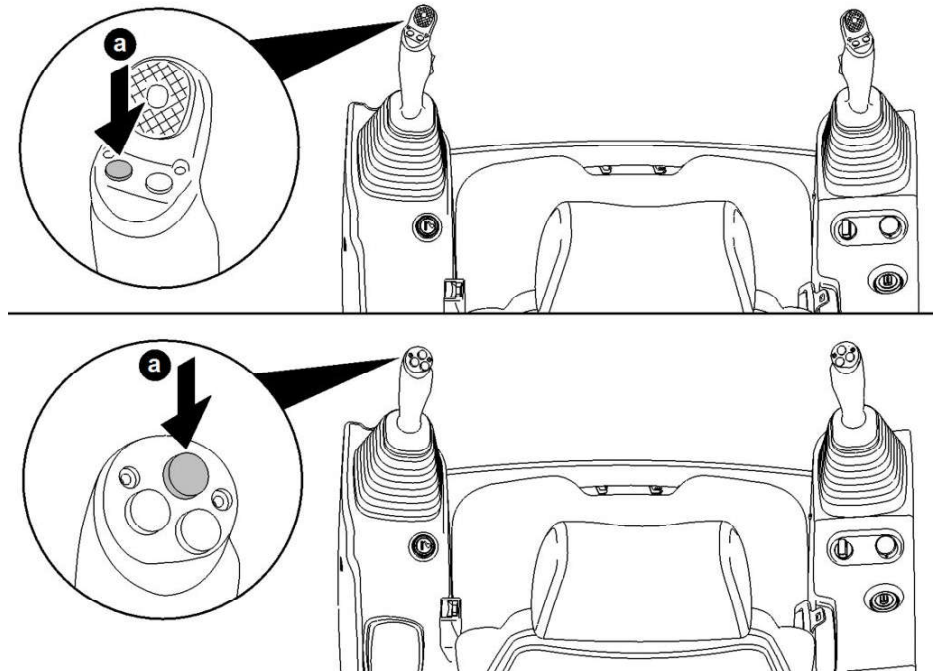

Fig. 277: Horn

Activating horn

- ▶ Press and hold button a.

Deactivating horn

- ▶ Release button a.

3.3.10 Tilting operator's cab (option)

The operator's cab can be tilted stagelessly to 30°.



DANGER

Unapproved presence in danger zone!
Danger to life.

- ▶ Make sure there are no persons in the danger zone under the operator's cab.
- ▶ While operator's cab is tilting, keep away from moving parts.



WARNING

Falling from operator's cab!
Injuries.

If operator's cab is tilted:

- ▶ Remain in operator's cab.
- ▶ Keep wearing safety belt.

Adjusting side area camera

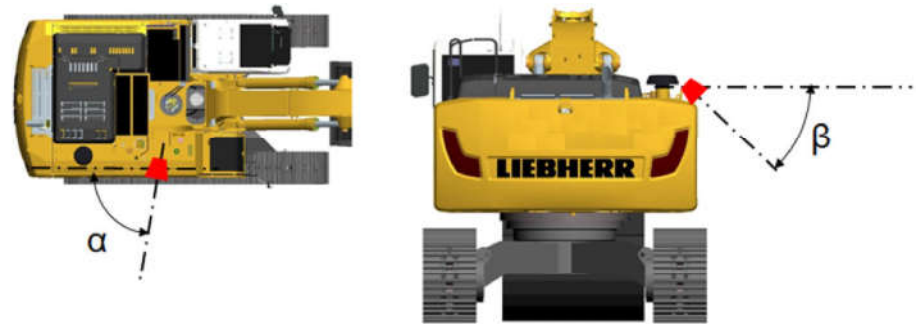

Fig. 294: Adjusting side area camera

Adjusting angle α

- ▶ Contact Liebherr customer service.

Adjusting angle β

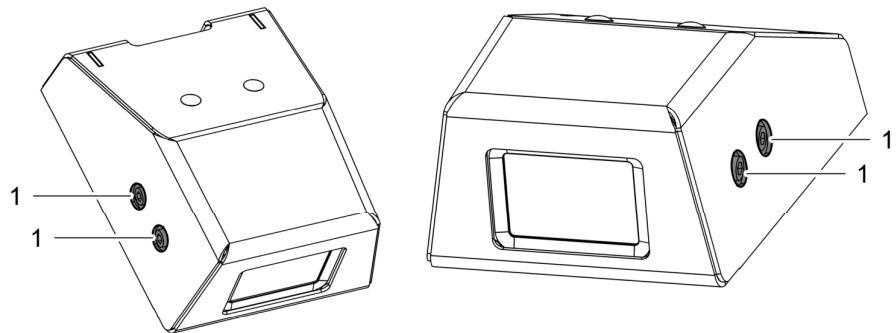

Fig. 295: Adjusting angle β

1 Adjusting screw

- ▶ Loosen adjusting screws 1.
- ▶ Align camera so that angle β is 33° . (see: fig. 294, page 129)
- ▶ Tighten adjusting screws 1.

3.4.4 Refuelling diesel exhaust fluid

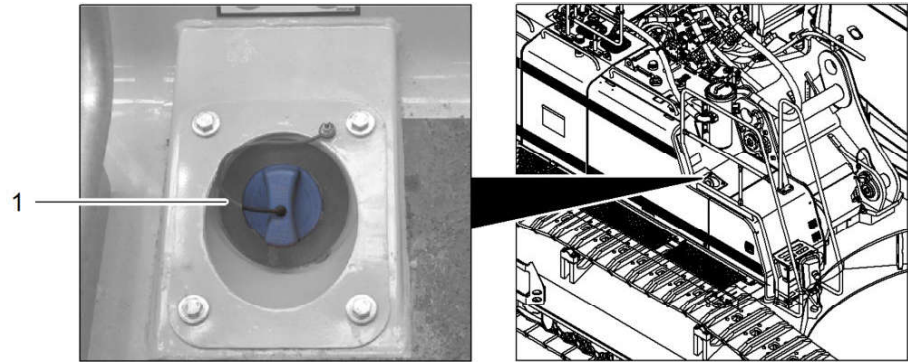

Fig. 316: Refuelling diesel exhaust fluid

1 Plug



CAUTION

Corrosive diesel exhaust fluid!
Injuries.

▶ Do not inhale vapours.

If skin comes into contact with diesel exhaust fluid:

▶ Clean affected areas with plenty of water and soap.

If eyes come into contact with diesel exhaust fluid:

▶ Rinse eyes under running water for at least 15 minutes.

▶ Consult a doctor if irritation persists.

If diesel exhaust fluid was swallowed:

▶ Do not vomit.

▶ Rinse mouth and drink plenty of water.

▶ Consult a doctor immediately.

▶ Adhere to safety data sheet of diesel exhaust fluid.

NOTICE

Corrosive diesel exhaust fluid!
Damage to machine.

▶ After contact with diesel exhaust fluid clean affected areas with plenty of water and soap.

▶ Adhere to safety data sheet of diesel exhaust fluid.

Refuelling

Make sure the following preconditions are met:

Strainer of diesel exhaust fluid tank is clean and in good condition.
 Diesel exhaust fluid used is approved. (For more information see: [5.3.2 Diesel exhaust fluids, page 268](#))

▶ Unscrew and remove plug 1.

▶ Fill diesel exhaust fluid tank.

▶ Screw in and tighten plug 1.

Releasing emergency stop button

- ▶ Press emergency stop button and turn clockwise.
- ▶ Set ignition key to 0.
- ▶ Set ignition key to I.

3.4.15 Travelling and braking

To ensure good visibility as per standard ISO 5006, the machine must be put in a precise travelling position.

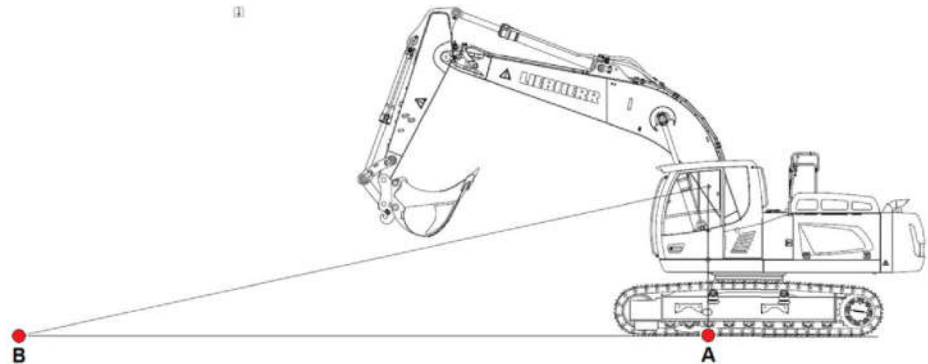

Fig. 339: Travelling position

Make sure the following preconditions are met:

- Uppercarriage is aligned parallel to undercarriage.
- Sprocket wheels are at back of the machine.
- Stick is as vertical as possible.
- Working tool is above operator's field of vision so that operator can see point B, which is 39' 4" ft-in away from point A. (see: fig. 339, page 149)

Travelling in straight line

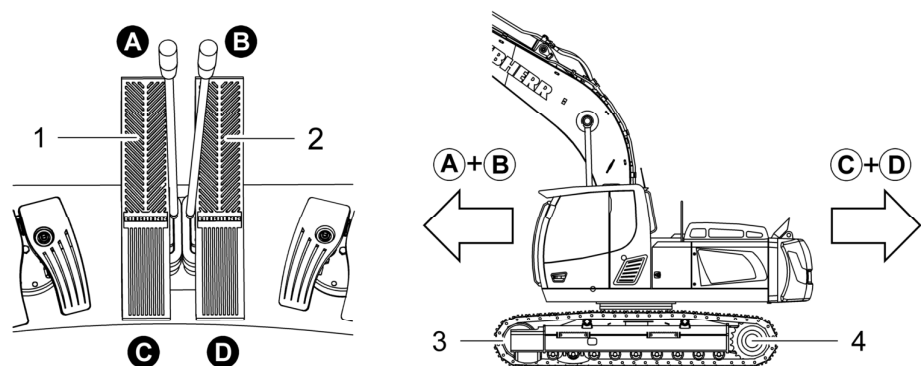

Fig. 340: Travelling in straight line

- | | | | |
|---|-------------------------|---|----------------|
| 1 | Left accelerator pedal | 3 | Idler-wheel |
| 2 | Right accelerator pedal | 4 | Sprocket wheel |

Make sure the following preconditions are met:

- Idler-wheel 3 is on front of machine.

CLICK HERE TO **DOWNLOAD** THE COMPLETE MANUAL

- Thank you very much for reading the preview of the manual.
- You can download the complete manual from: www.heydownloads.com by clicking the link below



- Please note: If there is no response to CLICKING the link, please download this PDF first and then click on it.

CLICK HERE TO **DOWNLOAD** THE COMPLETE MANUAL

Selecting operating mode

Key	Status of LEDs	Meaning
	○ ○ ○	OFF operating mode: Float position of bottom dump shovel attachment is deactivated.
	○ ○ ●	Continuous mode: Float position of bottom dump shovel attachment is active in continuous mode and is selectively deactivated with button a of right joystick. (For more information see: Selectively deactivating function for continuous mode, page 160)
	○ ● ○	Manual mode: Float position of bottom dump shovel attachment is active as long as a button of right joystick is pressed. (For more information see: Manually activating function for manual mode, page 160)

Tab. 34: Selecting operating mode



Note

Selected operating mode is saved and is activated the next time machine is started.

- ▶ Make sure that selected operating mode is adapted to work type and tool of machine.

Make sure the following preconditions are met:

- Bottom dump shovel attachment is down.
- ▶ Select operating mode: Press and hold *float position of bottom dump shovel attachment* key until required operating mode is selected.



Controlling flap of the bottom dump shovel

- ▶ Close flap of bottom dump shovel 4: Move right mini-joystick in direction a.
- ▶ Open flap of bottom dump shovel 4: Move right mini-joystick in direction b.

Controlling special working attachment with left mini-joystick

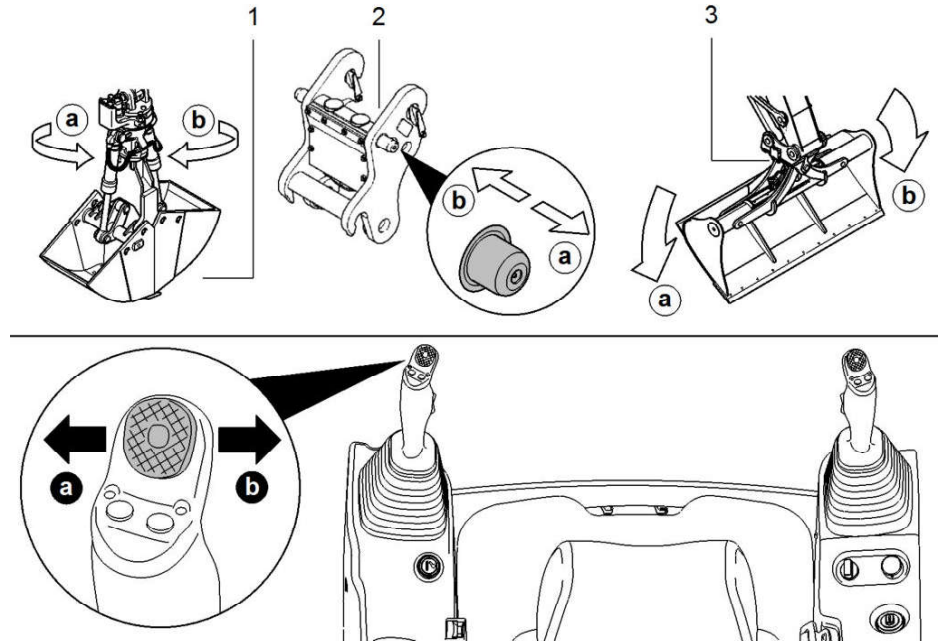

Fig. 388: Controlling special working attachment with left mini-joystick

- | | | | |
|---|------------------------------|---|----------------------------------|
| 1 | Grapple with rotary actuator | 3 | Swivelling ditch-cleaning-bucket |
| 2 | Hydraulic quick coupler | | |

Turning special working attachment

- ▶ Turn special working attachment to left a: Move left mini-joystick in direction a and hold in position.
- ▶ Turn special working attachment to right b: Move left mini-joystick in direction b and hold in position.

Controlling locking pins of the hydraulic quick coupler

- ▶ Extend locking pin of hydraulic quick coupler 2: Move left mini-joystick in direction a and hold in position.
- ▶ Retract locking pin of hydraulic quick coupler 2: Move left mini-joystick in direction b and hold in position.

► Position attachment into desired position for shut-off.

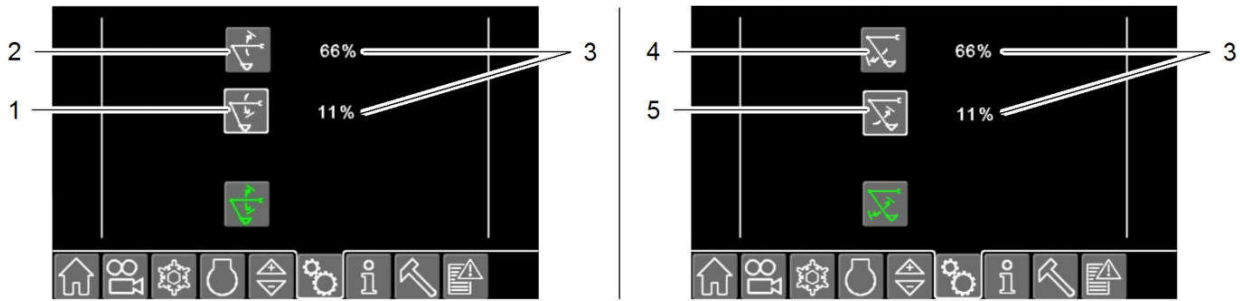

Fig. 424: Setting buttons and percentages of full stroke

- | | | |
|--|--|---|
| <p>1 Shut-off when lowering boom button</p> <p>2 Shut-off when lifting boom button</p> | <p>3 Percentage of full stroke</p> <p>4 Shut-off when extending stick button</p> | <p>5 Shut-off when retracting stick button</p> |
|--|--|---|

- Press corresponding setting button.
 - ▷ Selected setting button is yellow.
- Press confirmation button.
 - ▷ Selected setting button is white.
 - ▷ Percentages of full stroke **3** correspond to percentages of full stroke between the two mechanical stops.



Deactivating shut-off



DANGER
Deactivation of shut-off!
Danger to life.

- Proceed carefully when the shut-off is deactivated. Operator is responsible for potential accidents.

Deactivating shut-off selectively



- Press *deactivating stick cylinder shut-off key* or *deactivating hoist cylinder shut-off key*.
 - ▷ First LED of corresponding key flashes.
- Press confirmation button.
 - ▷ First LED of corresponding key lights up.

LFR/11821224/01/2019-06-20/en

- ▶ Align the teeth of the backhoe bucket so that the teeth can penetrate the ground at an angle of about 90°.
- ▶ Slowly and steadily retract the stick, and at the same time tilt the backhoe bucket inward.

If the stick is at right angles to the ground:

- ▶ Slowly and steadily raise the boom, and at the same time retract the stick and backhoe bucket.

If the backhoe bucket is full or the stick can no longer be retracted:

- ▶ Raise the boom and tilt the backhoe bucket in until the filling surface is parallel to the ground.

Dumping the material

- ▶ Position the working attachment at the dumping point.
- ▶ Slowly tilt the backhoe bucket outwards.

If material is left behind in the backhoe bucket:

- ▶ Tilt the backhoe bucket inwards and outwards.

3.6.7 Ground surface grading

A backhoe bucket or a dozer blade can be used for grading the ground surface.

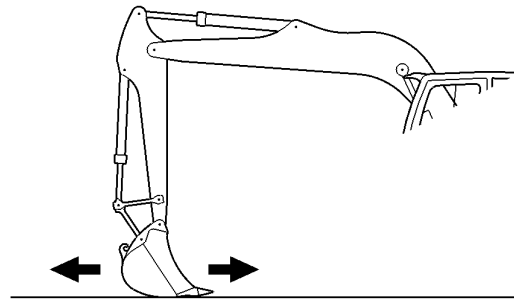

Fig. 445: Ground surface grading

NOTICE

Moving the machine with a working tool anchored in the ground!
Damage to the machine.

- ▶ Do not move the machine if a working tool is anchored in the ground.
-

Make sure that the following preconditions are met:

- Machine is in working position. (For more information see: [3.6.2 Putting machine in working position, page 185](#))

Grading with a backhoe bucket

- ▶ Lay the backhoe bucket flat on the ground.
- ▶ Compensate for the vertical movement of the stick: slowly retract or extend the stick and progressively raise or lower the boom.

3.7 Installing and removing working attachment

3.7.1 Installing and removing working attachment pins

Introduction

- ▶ Never align bores in working attachment with bare hands.

Removing working attachment pins

- ▶ Remove working attachment pins: Use hydraulic pin press.

If no hydraulic pin press is available:

- ▶ Use sledgehammer and mandrel held firmly by helper.

Installing working attachment pins

- ▶ Screw drive head supplied in tool box into threaded bore of pin of working attachment.
- ▶ Insert working attachment pin in bore of working attachment.
- ▶ Insert working attachment pins to the stop: Exclusively strike driver head.
- ▶ Screw in knurled nut until there is contact.
- ▶ Tighten knurled nut until roll pin can be inserted.

3.7.2 Installing and removing bucket

The affected working tools are:

- Backhoe bucket
- Ditch-cleaning bucket
- Ripper teeth

3.9 Installing and removing the counterweight

3.9.1 Installing and removing counterweight

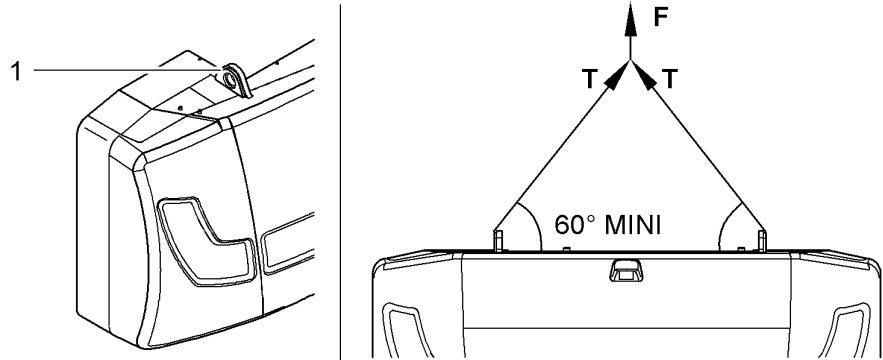

Fig. 461: Lifting counterweight

1 Lifting eye

The following table contains the values to be taken into account when selecting lifting accessories for a standard counterweight.

Weight of counterweight	Force F	Force T
19,841 lb	20,230 lb _r	11,690 lb _r
24,250 lb	24,730 lb _r	14,280 lb _r
27,557 lb	27,430 lb _r	15,850 lb _r

Tab. 42: Technical data

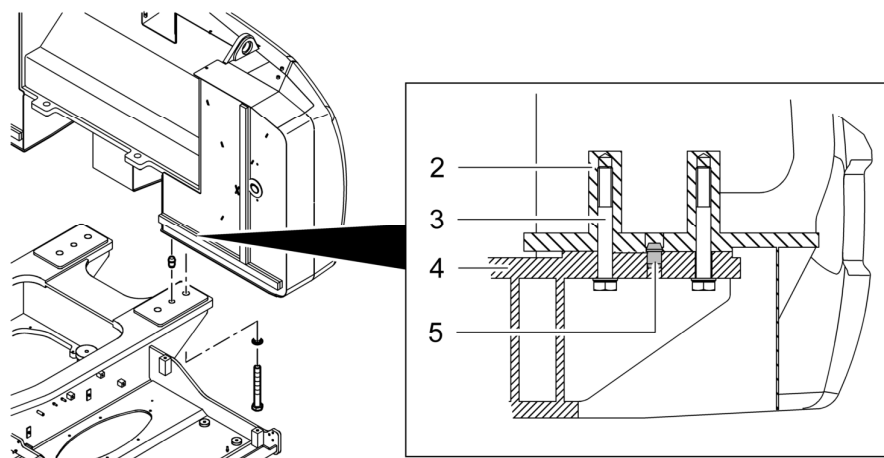

Fig. 462: Installing and removing counterweight

2 Counterweight
 3 Mounting bolts
 4 Uppercarriage
 5 Centring piece

LFR/11821224/01/2019-06-20/en

3.10.3 Driving machine onto low-loader (machine transporter)

Positioning machine on low-loader

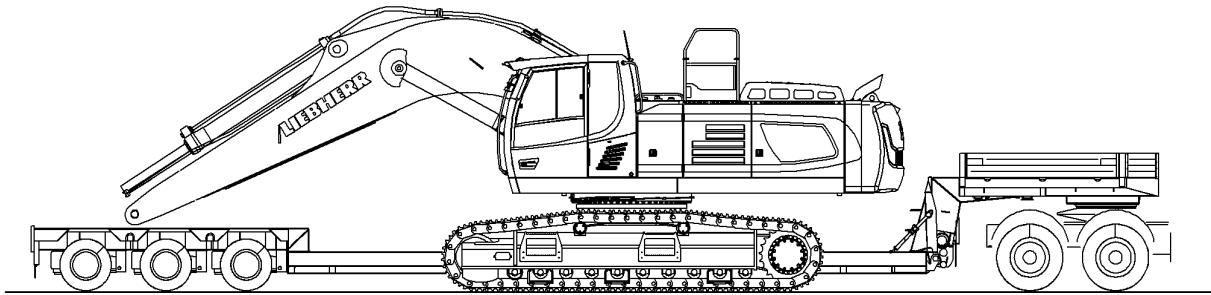

Fig. 479: Positioning machine on low-loader

Make sure the following preconditions are met:

- Travel gear is clean, free from snow and free from ice.
- Loading surface of low-loader is clean, free from snow and free from ice.
- Spotter is in eye contact with operator or speaking contact with operator is possible.
- The loading zone of the machine contains no persons.

Positioning undercarriage and uppercarriage

- ▶ Align undercarriage of machine with low-loader.
- ▶ Slightly lift working attachment.
- ▶ Align uppercarriage so that working attachment is in rear area of low-loader.

If machine is equipped with undercarriage with adjustable width:

- ▶ Retract side frames. (For more information see: [Retracting side frames, page 214](#))
- ▶ Unhitch low-loader from towing machine and position machine on low-loader platform.
- ▶ Place on tear-resistant, non-slip straps with a friction coefficient μ over 0.6 in accordance with standard EN 12195-1 between low-loader platform and centre part of machine undercarriage.
- ▶ Hitch low-loader to tractor truck and slowly raise low-loader platform to required transport height.

Positioning standard attachment

- ▶ Lower attachment to low-loader platform.
- ▶ Retract stick to maximum: Deactivate stick cylinder protection. (For more information see: [3.4.22 Stick cylinder protection, page 163](#))

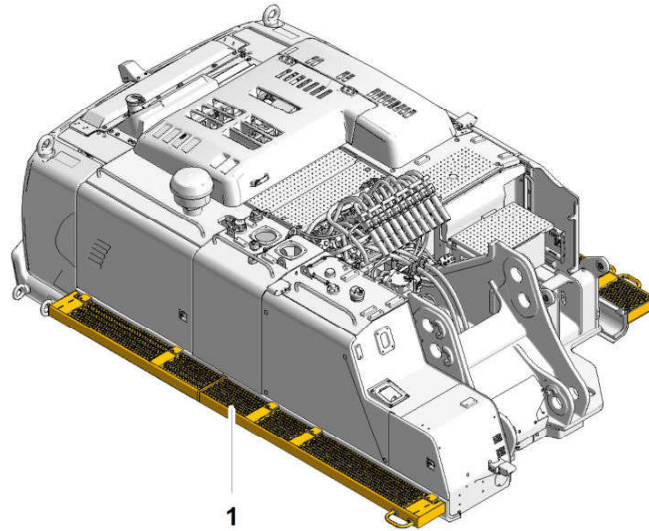













Fig. 492: Putting folding walkways into working position

1 Folding walkway

- ▶ Unscrew fasteners of folding walkways **1**.
- ▶ Put folding walkways **1** into working position.
- ▶ Secure folding walkways **1**.

Symbol	Meaning	Effect	Remedy
	Coolant level too low	Damage to diesel engine	Shut off diesel engine. Fill with coolant. If symbol is still displayed, contact Liebherr customer service.
	Warning threshold: Coolant temperature too high	Damage to diesel engine; automatic reduction of diesel engine power	Shut off diesel engine. Reduce load. Fill with coolant. Clean radiator. If symbol is still displayed, contact Liebherr customer service.
	Safety threshold: Coolant temperature too high		
	Air filter contaminated; dust collecting tank full	Damage to diesel engine; automatic reduction of diesel engine power	Empty dust collecting tank. Replace main filter cartridge of air filter.
	Warning threshold: Charge air temperature too high	Damage to diesel engine; automatic reduction of diesel engine power	Clean radiator. If symbol is still displayed, contact Liebherr customer service.
	Safety threshold: Charge air temperature too high		
	Warning threshold: Engine speed too high	Damage to diesel engine	Shut off diesel engine. Contact Liebherr customer service.
	Safety threshold: Engine speed too high	Automatic shut-off of diesel engine	Contact Liebherr customer service.
	Warning threshold: Oil pressure of diesel engine too low	Damage to diesel engine	Shut off diesel engine. Fill with diesel engine oil. If symbol is still displayed, contact Liebherr customer service.
	Safety threshold: Oil pressure of diesel engine too low		
	Warning threshold: Oil pressure of diesel engine too high	Damage to diesel engine	Shut off diesel engine. Correct oil level of diesel engine. Press <i>engine oil level</i> button in <i>measurement display</i> submenu. If symbol is still displayed, contact Liebherr customer service.
	Safety threshold: Oil level of diesel engine too low		

LFR/11821224/01/2019-06-20/en

4.3 Problem remedy

4.3.1 Fuses and relays

Resetting or replacing fuses

**DANGER**

Components under voltage!
Danger to life.

- ▶ Before working on electrical system, switch off battery main switch.
 - ▶ Before working on the electrical system, disconnect batteries from electric circuit.
-

**DANGER**

Bypassed fuses!
Danger to life.

- ▶ Exclusively use genuine fuses.
 - ▶ Do not bypass defective fuses.
-

- ▶ Identify cause of power failure.
- ▶ Repair or replace defective electrical components.
- ▶ Check condition and connection of fuse.

If fuse can be reset and is in good condition:

- ▶ Reset fuse.

or

If fuse is defective:

Replace fuse with original fuse of prescribed current value.

Electric cabinet E50

The electric cabinet E50 is on the partition behind the side door at the front left.

5 Maintenance

5.1 Inspection and maintenance schedule

General information

Abbreviations used in this section: h = operating hours

Shorten maintenance intervals according to operating conditions, for example:

- Dust intensive application
- Oil quality
- Fuel quality

Make sure lubricants, fluids and replaced parts are disposed of safely and in eco-friendly manner. Adhere to country-specific directives applicable in country of use and to relevant applicable laws.

The service packages in the spare parts catalogue contain the spare parts required for maintenance tasks.

Symbols	Affected employees
Filled-in symbols	Machine owner or their maintenance staff that perform maintenance tasks independently
Empty symbols	Trained staff authorised by Liebherr

Tab. 55: Meaning of symbols

5.3.3 Engine oils

Liebherr recommendation for stage IV / Tier 4f and stage V diesel engines

Description
Liebherr Motoroil 5W-30
Liebherr Motoroil 5W-30 low ash ²¹⁾

Tab. 62: Liebherr recommendation

Other approved engine oils²²⁾

Description
Liebherr Motoroil 10W-40
Liebherr Motoroil 10W-40 low ash ²¹⁾

Tab. 63: Other approved engine oils

Minimum quality requirements

Specification
LH-00-ENG3A LA ²¹⁾
ACEA E6, ACEA E9, API CJ-4

Tab. 64: Minimum quality requirements

If engine oils from other manufacturers are used, information on change intervals must be obtained from respective manufacturer or supplier.

Liebherr recommendation for other emission stages

Diesel engine power	Performance category
NaN KW	Power band I as per Regulation ECE-R.96 (stage 3A, TIER III, CHINA III equivalent)
NaN KW	Power band H as per Regulation ECE-R.96 (stage 3A, TIER III, CHINA III equivalent)

Tab. 65: Liebherr recommendation for other emission stages

Description
Liebherr Motoroil 10W-40

Tab. 66: Liebherr recommendation

²¹⁾ For machines with diesel particulate filter use low ash engine oil.

²²⁾ Adhere to change interval.

5.4.3 Access points on undercarriage

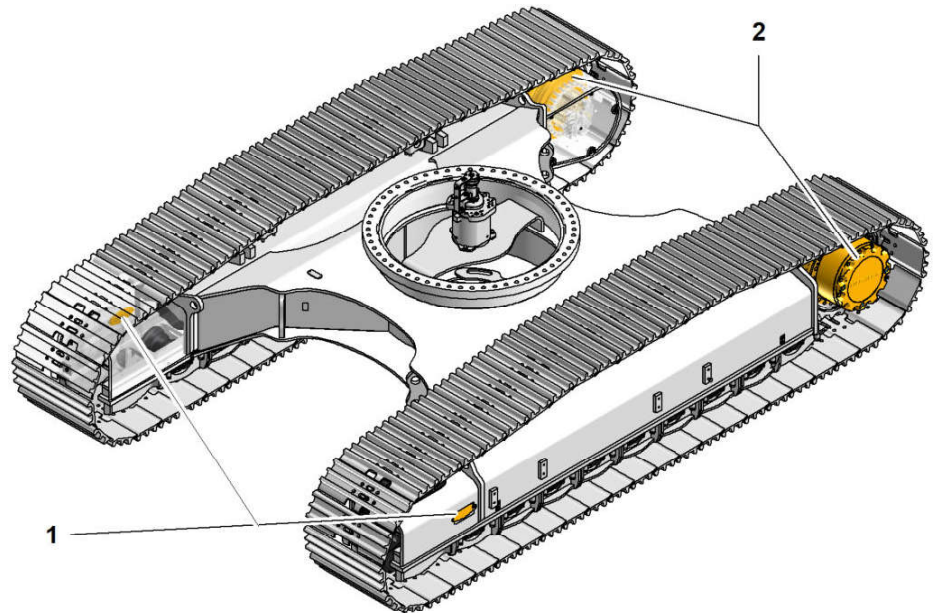

Fig. 588: Travel gear access points

1 Track tensioner

2 Travel gearbox

Different climatic conditions



Fig. 594: Icy climate



Fig. 595: Polar climate

LFR/11821224/01/2019-06-20/en

5.7 Complete machine

5.7.1 Checking machine for proper condition and tightness

Make sure the following precondition is met:

- Machine is in maintenance position.

5.7.2 Visual inspection before putting into service

NOTICE

Incorrect inspection tour!
Damage to machine.

- ▶ Perform visual inspections as per maintenance and inspection schedule.
- ▶ Check machine for proper condition.
- ▶ Check machine for tightness.
- ▶ Check machine for damage.

-
- ▶ Before putting machine into service, always perform inspection tour.
 - ▶ Perform maintenance tasks as per maintenance and inspection schedule every 8-10 h and 50 h.

5.7.3 Lubricating bearings on machine and working attachment

Lubricating bearings through central lubrication system

The following lubricating points are connected to central lubrication system:

- Lubricating points on basic boom
- Lubricating points on boom
- Lubricating points on stick

The lubricant quantity depends on the following factors:

- Viscosity of grease
- Connected components

NOTICE

Too little lubrication!
Damage to bearings.

- ▶ Make sure that grease emerges at all lubricating points.

If no grease emerges:

- ▶ Change lubrication mode.
 - ▶ Check lubrication lines.
-

- ▶ Remove plug of oil filling hole 1 (see: fig. 609, page 308) .
- ▶ Fill with oil via oil filling hole 1 (see: fig. 609, page 308) until oil level is between *MIN* mark and *MAX* mark.
- ▶ Clean plug of oil filling hole 1 (see: fig. 609, page 308) .
- ▶ Insert plug of oil filling hole 1 (see: fig. 609, page 308) .

5.8.3 Diesel engine: Checking condition, tightness and cleanliness

- ▶ Make a visual inspection to check diesel engine for leaks.
- ▶ Check fittings, motor head, oil pan, housing and diesel engine mounts for damage.
- ▶ Perform visual check of fittings, sealing points on engine head, oil pan, housing, etc. for oil leaks.
- ▶ Check whole diesel engine for excessive contamination.
- ▶ Make a visual inspection to check lines and hoses for leaks.
- ▶ Check lines and hoses for damage and that they are laid in an abrasion-free manner and they are mounted in accordance with regulations.

5.8.4 Fuel pre-filter: Draining water

The fuel pre-filter is on the radiator side under the engine bonnet.

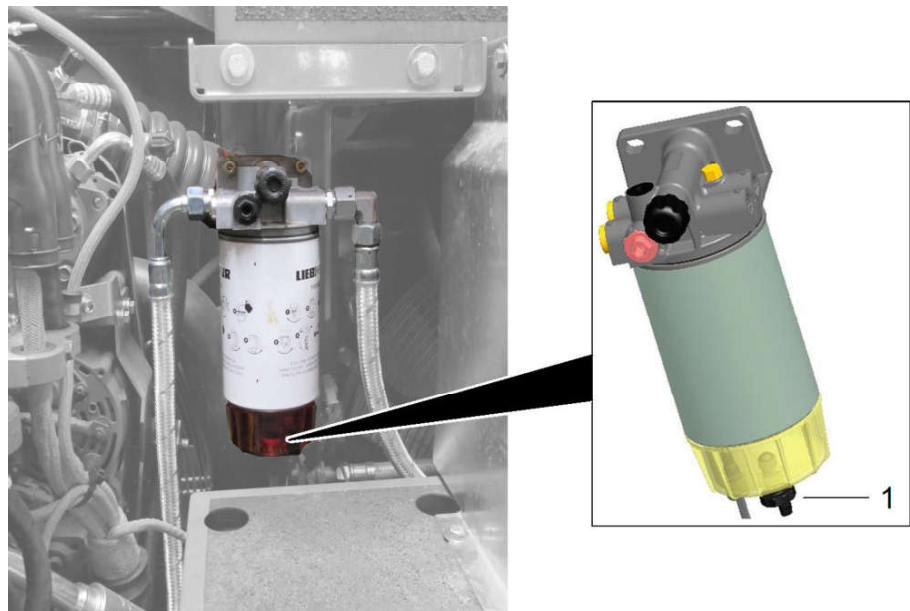

Fig. 610: Fuel pre-filter: Draining water

- 1 Water drain tap

**CAUTION**

Corrosive coolant!
Allergic reactions.

- ▶ Wear protective gloves and safety glasses.
- ▶ Avoid skin contact with coolant.
- ▶ Rinse thoroughly with water in case of direct skin contact.

Make sure the following preconditions are met:

- Coolant used is approved. (For more information see: [5.3.5 Coolant, page 271](#))
- ▶ Depressurise coolant container 2: Unscrew filler cap 4 by half a turn.
- ▶ Slowly and completely unscrew filler cap 4.
- ▶ Fill coolant to end of filler pipe at maximum 2.11 gal/min into coolant container 2.
- ▶ Check condition of sealing ring. Replace if necessary.
- ▶ Screw in filler cap 4.
- ▶ Regulate heating temperature of operator's cab to full.
- ▶ Let diesel engine run at idle speed for 5 minutes.
- ▶ Check coolant level. (For more information see: [Checking coolant level, page 318](#))

5.9.2 Coolant: Checking concentration

Checking concentration of anti-freeze and corrosion protection agent in coolant

Checking temperature of anti-freeze and corrosion protection agent

- ▶ Take coolant sample.
- ▶ Use suitable method to test whether temperature of anti-freeze and corrosion protection agent is -35°F .

If temperature of anti-freeze and corrosion protection agent is higher than -35°F :

- ▶ Correct concentration of anti-freeze and corrosion protection agent. (For more information see: [Correcting concentration of anti-freeze and corrosion protection agent, page 320](#))

5.11 Electrical system

5.11.1 General information

Preparatory work

Before any intervention in electrical system:

- ▶ Wear safety glasses and protective gloves.
- ▶ Switch off battery main switch.
- ▶ Disconnect batteries: Disconnect negative pole (-) first and reconnect it last.

General maintenance work

- ▶ Regularly check flawless condition of the electrical system.
- ▶ Remedy malfunctions immediately.

Malfunctions could be, for example:

- Loose connections
- Damaged cables
- Inadequately attached clamps

If fuse or bulb is damaged:

- ▶ Remedy cause.
- ▶ Replace damaged fuse or bulb immediately.

5.15 Lubrication system

5.15.1 Lubrication system (option): Topping up grease

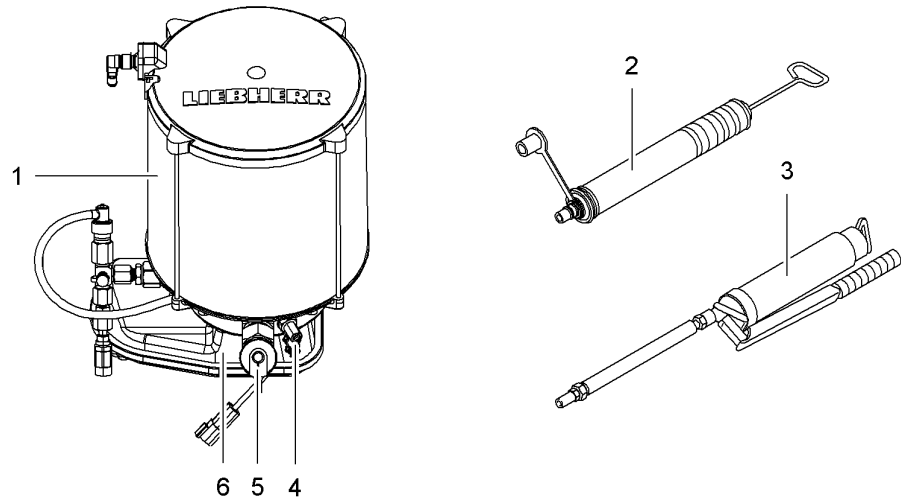

Fig. 653: Lubrication system: Topping up grease

- | | | | |
|---|------------------|---|----------------------|
| 1 | Grease container | 4 | Grease fitting |
| 2 | Filling pump | 5 | Filling pump adapter |
| 3 | Grease gun | 6 | Lubricating pump |

NOTICE

Incorrect filling of grease!
Damage.

- ▶ Regularly check fill level of grease container.
- ▶ Exclusively fill with grease via filling pump adapter or grease fitting.

Grease used is approved. (For more information see: [5.3.9 Greases, page 276](#))

- ▶ Insert grease cartridge in filling pump 2.
- ▶ Connect filling pump 2 to filling pump adapter 5.
- ▶ Press content of grease cartridge into grease container 1.

If no filling pump 2 is available:

- ▶ Fill in grease with grease gun 3 via grease fitting 4.

5.15.2 Checking lubrication of bearings (grease collar)

- ▶ Check all connected lubricating points for sufficient lubricant distribution.

CLICK HERE TO **DOWNLOAD** THE COMPLETE MANUAL

- Thank you very much for reading the preview of the manual.
- You can download the complete manual from: www.heydownloads.com by clicking the link below



- Please note: If there is no response to CLICKING the link, please download this PDF first and then click on it.

CLICK HERE TO **DOWNLOAD** THE COMPLETE MANUAL