

en

Operator's manual

Hydraulic excavator

Document ID

	ORIGINAL OPERATOR'S MANUAL
Order number:	11827505
Issued:	2018-08-31
Version:	01
Author:	LFR / Technical Documentation Department

Product ID

Manufacturer:	Liebherr-France SAS
Type:	R 946
Type no.:	1491 (USA / CAN)
From Serial no.:	40137

Contact

Liebherr-France SAS
2 avenue Joseph Rey, B.P. 90287
F – 68005 Colmar Cedex

CLICK HERE TO **DOWNLOAD** THE COMPLETE MANUAL

- Thank you very much for reading the preview of the manual.
- You can download the complete manual from: www.heydownloads.com by clicking the link below



- Please note: If there is no response to CLICKING the link, please download this PDF first and then click on it.

CLICK HERE TO **DOWNLOAD** THE COMPLETE MANUAL

3.3.14	Viewing devices	121
3.3.15	Lighting	128
3.3.16	Cab lighting system	129
3.3.17	Windscreen wipers	130
3.3.18	Auxiliary heater (option)	130
3.4	Operation	132
3.4.1	Inspection tour before putting into service	132
3.4.2	Refuelling	133
3.4.3	Refuelling with the electric refuelling pump (option)	134
3.4.4	Filling with diesel exhaust fluid	136
3.4.5	Immobiliser (option)	136
3.4.6	Preparing machine for dust intensive application	138
3.4.7	Preparing machine for use in biologically sensitive areas	138
3.4.8	Starting diesel engine	138
3.4.9	Bringing machine to operating temperature	139
3.4.10	Engine speed and operating mode	140
3.4.11	After starting	141
3.4.12	Sensor-controlled low idle automatic	142
3.4.13	Automatic engine shut-off after idling (option)	143
3.4.14	Shutting off diesel engine	143
3.4.15	Travelling and braking	145
3.4.16	Travel alarm (option)	149
3.4.17	Controlling the working attachment	149
3.4.18	Turning and braking uppercarriage	151
3.4.19	Turning alarm (option)	153
3.4.20	Hoist cylinder protection (option)	154
3.4.21	Stick cylinder protection	156
3.4.22	Controlling special working attachment without mini-joystick (option)	157
3.4.23	Controlling special working attachment with mini-joystick (option)	160
3.4.24	Tiltrotator (option)	162
3.4.25	Control changeover (option)	163
3.4.26	Changing over control of right mini-joystick (option)	165
3.4.27	Changing over control of left double pedal (option)	167
3.4.28	Changing over control of joystick control (option)	169
3.4.29	Grapple priority (option)	169

1.2.3 Specifications

The specifications for this machine are contained in the following technical description.

Less fuel

The new 6-cylinder Liebherr engine, pursuant to the Final 4 Tier/Stage IV emission standards, comprises a diesel exhaust fluid injection device (SCR) for the after-treatment of exhaust gases, with no need for a particle filter. Associated with the latest technological advances in hydraulics, this engine consumes less fuel, both in terms of hours of operation and in terms of tons of material moved.

Increased productivity

Clearly enhanced performance and lower consumption, all in a comfortable and ergonomic work environment, lead to remarkable gains in productivity in all operating configurations.

Simplified and lower-cost maintenance

Non-slip platforms and ergonomic handles allow fast and easy access to all maintenance points not accessible from the ground. The absence of a particle filter reduces maintenance time, the cost of spare parts and filter regeneration operations.

Electronic power control

This control system allows the engine power to be effectively and optimally converted, from an energetic point of view, into hydraulic power. This is as a result of greater forces, a faster working speed and a lower fuel consumption.



Liebherr Lubricants

- Liebherr lubricants are specially developed for application in Liebherr earth moving and material handling machines and guarantee a long working life whilst simultaneously delivering the highest possible performance
- Being designed especially for your Liebherr machines, Liebherr lubricants contribute significantly to lowering your operating and maintenance costs.

Liebherr tools

- Wide range of tools suitable for every type of application
- Tools designed for maximum productivity and durability
- Shape of buckets designed to assist the filling and stability of bulky materials during the transport stages
- Hydraulic quick coupler system

Modular quick-change system made by Liebherr

- Likufix – connects all hydraulically mounted tools without having to leave the operator's cab, maximum productivity due to tool change being performed in a matter of seconds
- The suitable digging tool for every application. Your machine is a multifunctional tool carrier and will pay for itself very quickly indeed
- Mechanic and hydraulic Liebherr quick-change adapter



Operator's Cab

Cab	ROPS safety cab structure with individual windscreens or featuring a slide-in subpart under the ceiling, work headlights integrated in the ceiling, a door with a sliding window (can be opened on both sides), large stowing and depositing possibilities, shock-absorbing suspension, sounddamping insulating, tinted laminated safety glass, separate window shades for the sunroof window and windscreen, cigarette lighter and 12 V plug, storage bins, lunchbox, cup holder
Operator's seat	Liebherr-Comfort seat, airsprung with automatic weight adjustment, vertical and longitudinal seat damping including consoles and joysticks. Seat and armrests adjustable separately and in combination, seat heating as standard
Control system	arm consoles, swinging with the seat
Operation and displays	large high-resolution color display with selfexplanatory operation via touchscreen, video, versatile adjusting, control and monitoring facilities, e.g. climate control, implement and tool parameters
Air-conditioning	standard automatic air-conditioning fully controlled on the display, ambient air function, fast de-icing and demisting at the press of a button, air vents can be operated via a menu. Ambient air and fresh air filters can be easily replaced and are accessible from outside and standing on the ground. Heating-cooling unit, designed for extreme outside temperatures, sensors for solar radiation, inside and outside temperatures
Noise emission	
ISO 6396	L_{pA} (inside cab) = 72 dB(A)
2000/14/EC	L_{WA} (surround noise) = 106 dB(A)



Undercarriage

Versions	
NLC	gauge 7'10"
LC	gauge 8'6"
LC-V	gauge 7'10" (transport position) gauge 9'6" (work position)
Drive	Liebherr swashplate motors with integrated brake valves on both sides
Transmission	Liebherr planetary reduction gears
Travel speed	NLC/LC: low range – 2.0 mph high range – 3.7 mph LC-V: low range – 1.9 mph high range – 2.9 mph
Net drawbar pull on crawler	NLC/LC: 67,668 lbf LC-V: 81,606 lbf
Track components	NLC/LC: D7, maintenance-free LC-V: D7G, maintenance-free
Track rollers / Carrier rollers	9/2
Tracks	sealed and greased
Track pads	triple grouser
Holding brake	wet multi-discs (spring applied, pressure released)
Brake valves	integrated into travel motor
Lashing eyes	integrated



Attachment

Type	combination of resistant steel plates and cast steels components
Hydraulic cylinders	Liebherr cylinders with special seal-system, shock protection
Bearings	sealed, low maintenance
Lubrication	automatic central lubrication system (except link and tilt geometry)
Hydraulic connections	pipes and hoses equipped with SAE splitflange connections
Bucket	standard equipped with Liebherr tooth system

Lift Capacities

with Mono Boom 21'2" and Counterweight 19,840 lb

Stick 6'11"

ft	Under-carriage	10 ft		15 ft		20 ft		25 ft		30 ft		35 ft		ft in
		LC	LC-V	LC	LC-V	LC	LC-V	LC	LC-V	LC	LC-V	LC	LC-V	
35	NLC LC LC-V													
30	NLC LC LC-V													
25	NLC LC LC-V					24.5'	24.5'					21.2'	21.2'	21'7"
20	NLC LC LC-V					24.0'	25.3'	16.9'	21.1'			16.8'	19.9'	25'1"
15	NLC LC LC-V			34.0'	37.2'	22.8'	28.1'	16.5'	24.0'			14.5'	19.7'	27'2"
10	NLC LC LC-V			38.0'	38.0'	28.3'	28.3'	22.2'	24.1'			13.4'	20.3'	28'4"
5	NLC LC LC-V					20.0'	33.3'	15.3'	26.0'			13.0'	21.6'	28'5"
0	NLC LC LC-V			29.8'	36.2'	20.0'	33.6'	15.1'	25.6'			13.4'	22.5'	27'7"
-5	NLC LC LC-V	27.4'	27.4'	30.1'	40.6'	20.0'	31.8'	15.1'	24.6'			14.7'	23.4'	25'8"
-10	NLC LC LC-V	40.3'	40.3'	30.7'	34.7'	20.5'	27.2'					17.7'	22.6'	22'7"
-15	NLC LC LC-V	39.5'	39.5'	33.9'	33.9'	26.5'	26.5'					22.5'	22.5'	16'7"

Stick 8'6"

ft	Under-carriage	10 ft		15 ft		20 ft		25 ft		30 ft		35 ft		ft in
		LC	LC-V	LC	LC-V	LC	LC-V	LC	LC-V	LC	LC-V	LC	LC-V	
35	NLC LC LC-V													
30	NLC LC LC-V													
25	NLC LC LC-V													16.6" 16.6" 16.6" 16.6" 23' 7" 16.5" 16.5"
20	NLC LC LC-V							23.7" 23.7"	17.2 21.9'					15.2 15.7" 15.7 15.7" 26'10" 15.6" 15.6"
15	NLC LC LC-V			34.4" 34.4"	34.4" 34.4"	25.0 26.6"	18.0 22.9"	23.9" 23.9"	21.9' 21.9'					13.3 15.6" 14.4 15.6" 28'10" 15.6" 15.6"
10	NLC LC LC-V			31.7 42.2'	21.7 30.0"	16.0 24.5'		34.8 42.2'	23.6 30.0"	17.3 24.5'				12.4 16.0" 13.4 16.0" 29'10" 16.0" 16.0"
5	NLC LC LC-V			29.9 31.6"	20.5 32.6"	15.3 25.8"		31.6" 31.6"	22.4 32.6"	16.7 25.8"				12.1 16.9" 13.1 16.9" 29'11" 16.5 17.0"
0	NLC LC LC-V			29.5 42.1"	19.9 33.5"	15.0 25.5"		31.9" 31.9"	28.3 32.8"	21.0 25.9"				12.3 18.7" 13.4 18.7" 29' 1" 17.0 18.9"
-5	NLC LC LC-V	30.7" 30.7"	30.7" 30.7"	29.6 42.5"	19.8 32.5"	14.9 25.4"		32.9" 32.9"	27.7 33.5"	20.6 25.4"				13.3 21.8" 14.5 21.8" 27' 5" 18.5 22.2"
-10	NLC LC LC-V	47.0" 47.0"	47.0" 47.0"	30.2 37.4"	20.1 29.0"			47.0" 47.0"	33.2 37.4"	22.0 29.0"				15.6 21.9" 17.0 21.9" 24' 6" 21.8" 21.8"
-15	NLC LC LC-V	46.2" 46.2"	46.2" 46.2"	36.7" 36.7"	28.0 28.5"			28.1" 28.1"	28.1" 28.1"	20.0" 20.0"				20.0" 20.0" 20" 19.6" 19.6"

Stick 9'6"

ft	Under-carriage	10 ft		15 ft		20 ft		25 ft		30 ft		35 ft		ft in
		LC	LC-V	LC	LC-V	LC	LC-V	LC	LC-V	LC	LC-V	LC	LC-V	
35	NLC LC LC-V													
30	NLC LC LC-V													
25	NLC LC LC-V													16.0" 16.0"
20	NLC LC LC-V													14.4" 14.4" 14.4" 14.4" 24' 8" 14.3" 14.3"
15	NLC LC LC-V													17.2 20.9" 18.6 20.9" 21.0" 21.0"
10	NLC LC LC-V													12.8 20.2" 13.6" 13.6" 27'10" 13.6" 13.6"
5	NLC LC LC-V													12.6 13.5" 13.5" 13.5" 28'10" 13.5" 13.5"
0	NLC LC LC-V													11.7 13.8" 11.7 13.8" 30' 8" 13.9" 13.9"
-5	NLC LC LC-V	30.0" 30.0"	30.0" 30.0"	29.5 43.4"	19.6 32.7"	14.7 25.2"								11.4 14.6" 12.4 14.6" 30'10" 14.7" 14.7"
-10	NLC LC LC-V	50.6" 50.6"	29.9 38.7"	19.9 29.7"	15.0 22.4"									11.6 16.1" 12.6 16.1" 30' 1" 16.1 16.3"
-15	NLC LC LC-V	30.0" 30.0"	32.5 43.4"	21.5 32.7"	16.0 25.3"									12.5 18.6" 13.6 18.6" 28' 5" 17.5 19.9"

Stick 10'10"

ft	Under-carriage	10 ft		15 ft		20 ft		25 ft		30 ft		35 ft		ft in
		LC	LC-V	LC	LC-V	LC	LC-V	LC	LC-V	LC	LC-V	LC	LC-V	
35	NLC LC LC-V													
30	NLC LC LC-V													13.6" 13.6" 13.6" 13.6" 21'10" 13.5" 13.5"
25	NLC LC LC-V													17.6" 17.6" 17.6" 17.6" 26' 4" 18.4" 18.4"
20	NLC LC LC-V													17.4 19.8" 18.7 19.8" 19.8" 19.8"
15	NLC LC LC-V													23.5 24.2" 24.2" 24.2" 24.5" 24.5"
10	NLC LC LC-V													16.8 21.1" 16.0 23.0" 17.0 18.1"
5	NLC LC LC-V													12.5 17.5" 11.5" 11.5" 31" 11.5" 11.5"
0	NLC LC LC-V													32.8 38.3" 36.0 38.3" 39.0" 39.0"
-5	NLC LC LC-V													22.0 28.0" 23.9 28.0" 28.3" 28.3"
-10	NLC LC LC-V													16.0 23.0" 17.3 23.0" 13.2 20.2"
-15	NLC LC LC-V													16.6 20.3" 16.6 20.3" 32' 11.8 11.8" 32' 11.8" 11.8"

Height Can be slewed though 360° In longitudinal position of undercarriage Max. reach * Limited by hydr. capacity

The load values are quoted in lb x 1,000 at stick end (without bucket), and may be swung 360° on firm and even ground. Adjacent values are valid for the undercarriage when in the longitudinal position. Capacities are valid for 30" wide track pads. Indicated loads are based on ISO 10567 standard and do not exceed 75% of tipping or 87% of hydraulic capacity (indicated via *). Without bucket cylinder, link and lever the lift capacities will increase by 1,380 lb. Lifting capacity of the excavator is limited by machine stability and hydraulic capacity.

- Collect and store fuels, operating fluids and lubricants in suitable containers before disposal.
- Adhere to instructions of relevant manufacturer when disposing of fuels, operating fluids and lubricants.
- Have fuels, operating fluids and lubricants disposed of by old oil recycling point.
- Have metal parts disposed of by metal recycling point.
- Have plastic parts disposed of by plastic recycling point.
- Have rubber parts disposed of by rubber recycling point.
- Have electronic components disposed of by electronics recycling point.

2.3 Description of staff

2.3.1 Personal protective equipment

Operators, assistants and maintenance staff are responsible for the following:

- Wearing personal protective equipment
- Regular cleaning and care of protective equipment
- Immediate replacement of damaged parts of protective equipment

The protective equipment consists of following elements:

- Protective helmet
- Safety glasses
- Hearing protection
- Breathing equipment
- Protective gloves
- Warning clothing (reflective, in signal colour)
- Safety boots
- Special protective clothing
 - To prevent burns
 - To prevent freezing
 - To prevent acid burns
 - To prevent stabbing and cutting injuries

2.3.2 Requirements for staff

- Make sure that exclusively authorised and trained persons operate, maintain or repair the machine.
- Make sure that all persons operating, maintaining or repairing the machine have the specified minimum age.
- Make sure that staff training involves theoretical information (technology and safety) and practical training on the machine.
- Make sure that the staff have read and understood the operator's manual and supplied documentation.
- Make sure that staff undergoing training, education, instruction, or a general apprenticeship exclusively work on the machine under constant supervision by an experienced person.
- Regularly check safety-aware and danger-aware working of staff.
- Clearly specify staff responsibility for operation, set-up, maintenance and repair work.



DANGER

Failure to adhere to information signs!
 Danger to life.

- ▶ Regularly check condition of information signs.
- ▶ Immediately replace any incomplete, illegible or missing information signs.
- ▶ Adhere to information signs.

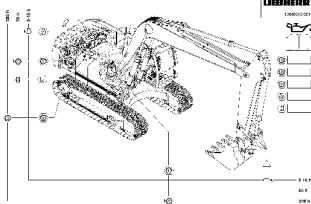
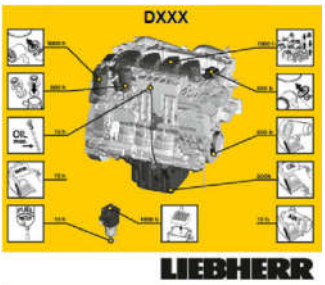
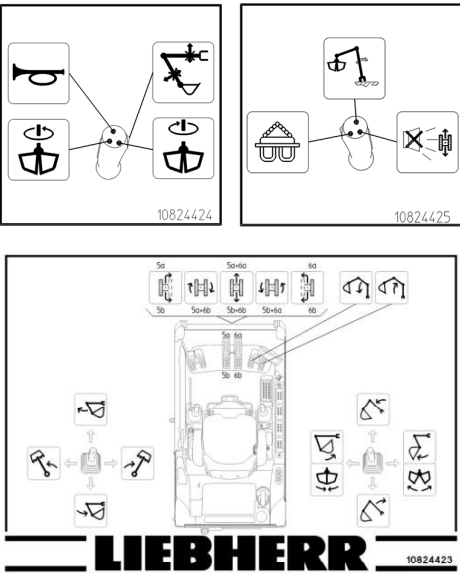
Sign	Description	
30		<p>Lubrication chart Shows lubrication tasks.</p>
31		<p>Engine lubrication chart Shows maintenance tasks on the diesel engine.</p>
32		<p>Description of the control elements Displays function allocation for pedals and joysticks.</p>

LFR/11827505/01/2018-05-31/en

- Keep your face towards machine during entry and exit.
- Make sure you always have two hands and a foot or two feet and one hand in contact with the access system.
- After entering the operator's cab, find out about emergency exit.

If the machine has an operator's cab elevation:

- Climb until the door is reached.
- When you reach door handle with your free hand: Open door.
- Continue climbing.

Adhere to safety instructions on entry and exit in operator's manual of complete machine:

- If the uppercarriage is mounted on a support.
- If the machine is part of a system.
- If the uppercarriage is mounted on a pontoon or rail guide system.

2.7.5 Machine danger zone

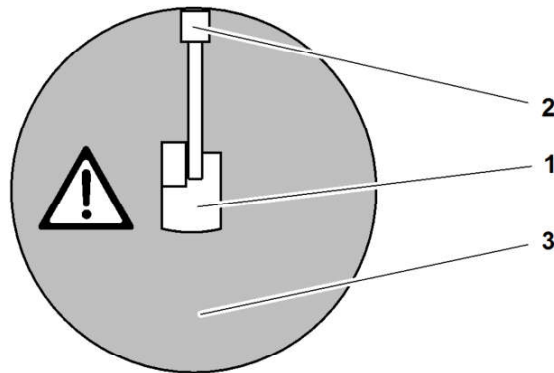

Fig. 58: Machine danger zone (view from above)

- | | | | |
|---|-----------------------------|---|-------------|
| 1 | Machine | 3 | Danger zone |
| 2 | Reach of working attachment | | |

Danger to life

Unapproved presence in danger zone

- Make sure there are no persons in danger zone.

2.7.6 Visibility













Danger to life

Insufficient visibility





- Make sure that persons approach machine from the front and within operator's field of vision.
- Make sure that persons contact the operator before approaching the machine.
- Make sure that no obstacles impair visibility in the working area.
- Use viewing devices to observe environment of machine if necessary.
- Use viewing devices if necessary to observe areas around the machine that cannot be seen directly.

- | | | | |
|-----------|---|-----------|-------------------------------------|
| 4a | Joystick | 14 | Engine speed controller |
| 4b | Joystick with mini-joystick ¹⁾ | 15 | Control unit C ¹⁾ |
| 5 | Left double pedal ¹⁾ | 16 | Starting switch |
| 6 | Travelling pedals | 17 | Emergency stop button ¹⁾ |
| 7 | Travel lever | 18 | Control unit D ¹⁾ |
| 8 | Right double pedal ¹⁾ | 19 | Control unit E ¹⁾ |
| 9 | Display | | |

¹⁾ Option

Symbol	Meaning
	Unlocking of quick coupler 2 in progress
	Locking of quick coupler in progress
	Locking of quick coupler 2 in progress
	Quick coupler unlocked
	Quick coupler 2 unlocked
	No working tool in locking position
	Quick coupler at boom end active
	Quick coupler at boom end active
	Unlocking of quick coupler at boom end in progress
	Locking of quick coupler at boom end in progress
	Quick coupler at basic boom end unlocked
	No working attachment in locking position

Tab. 16: Status of quick coupler

Menu buttons	Designation
	Preferences and diagnosis (For more information see: 3.2.17 <i>Unit selection</i> submenu, page 83) (For more information see: 3.2.18 <i>Time zone</i> submenu, page 84) (For more information see: 3.2.19 <i>Time format and date format</i> submenu, page 84) (For more information see: 3.2.20 <i>Language selection</i> submenu, page 84) (For more information see: 3.2.21 <i>Test system</i> submenu, page 85) (For more information see: 3.2.23 <i>Electrical outputs</i> submenu, page 86) (For more information see: 3.2.24 <i>Electrical inputs</i> submenu, page 87)
	Unlocking with PIN code
	Electrical outputs (For more information see: 3.2.23 <i>Electrical outputs</i> submenu, page 86)
	Electrical inputs (For more information see: 3.2.24 <i>Electrical inputs</i> submenu, page 87)

Tab. 18: System settings menu

3.2.11 Operating hour meter submenu

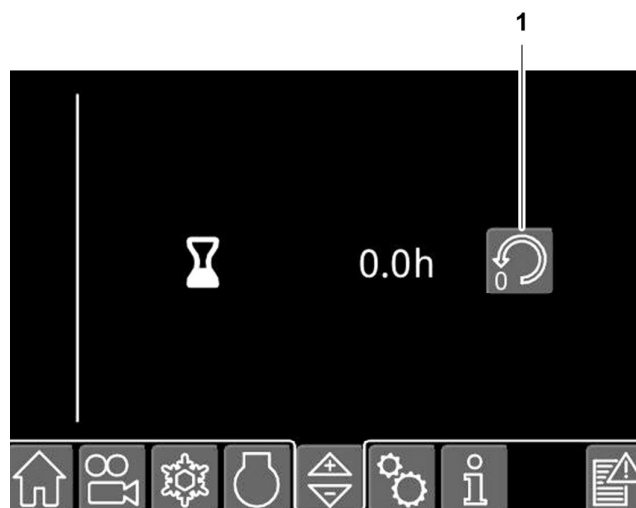









Fig. 172: Operating hour meter submenu

- 1 Resetting daily operating hour meter button

Menu buttons	Designation
	Automatic reversing fan drive (For more information see: 3.2.30 <i>Automatic reversible fan drive</i> submenu (option), page 95)
	Bleeding engine oil circuit Bleeding oil filter
	Bleeding control valve block
	Priority between lifting boom and turning uppercarriage (For more information see: 3.2.31 <i>Priority between lifting boom and turning uppercarriage</i> submenu, page 95)
	Priority between lifting boom and controlling working attachment
	Stick priority (For more information see: 3.2.32 <i>Stick priority</i> submenu (option), page 96)
	Extended access

Tab. 19: Function settings menu

3.2.26 Central lubrication system submenu

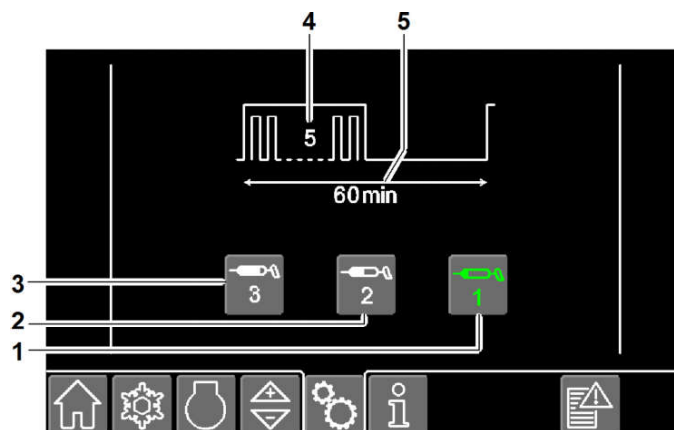

Fig. 202: Central lubrication system submenu

- | | | | |
|---|---------------|---|---------------------------|
| 1 | Mode 1 button | 4 | Cycle rate of lubrication |
| 2 | Mode 2 button | 5 | Time period |
| 3 | Mode 3 button | | |

If the central lubrication system is equipped with two lubricating pumps, the menu is shown in two columns.

3.2.36 CodingKey submenu



Fig. 231: CodingKey submenu

- | | | | |
|---|---------------------------------|---|----------------------------------|
| 1 | CodingKey of machine | 3 | Number of installed working tool |
| 2 | CodingKey of working attachment | | |

3.2.37 Tool Control menu

In *Tool Control* menu a special working attachment can be selected and the corresponding parameters can be activated.

Multiple special working attachments can be programmed. For setting and saving parameters for special working attachments contact Liebherr customer service.

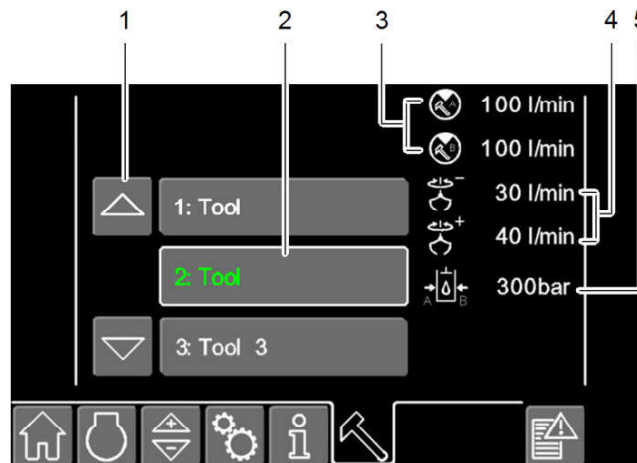

Fig. 232: Tool Control menu

- | | | | |
|---|---|---|---|
| 1 | Scroll button | 4 | Maximum flow rate in medium pressure circuit of special working attachment during operation |
| 2 | Selected special working attachment button | 5 | Maximum pressure of special working attachment in operation |
| 3 | Maximum flow rate in high pressure circuit of special working attachment during operation | | |

**DANGER**

Unexpected machine movement!
Danger to life.

- ▶ Exclusively adjust operator's seat when safety lever or folding console is in upper position.

Adjusting seat position

Fig. 260: Adjusting seat position

A Adjusting seat position without armrests

B Adjusting seat position with armrests

Adjusting armrests

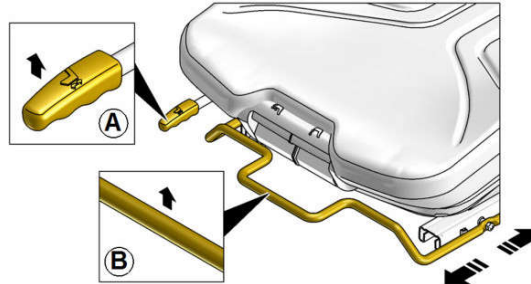
Fig. 261: Adjusting armrest angle

3.3.12 Sun blind

Sun blind on windscreen

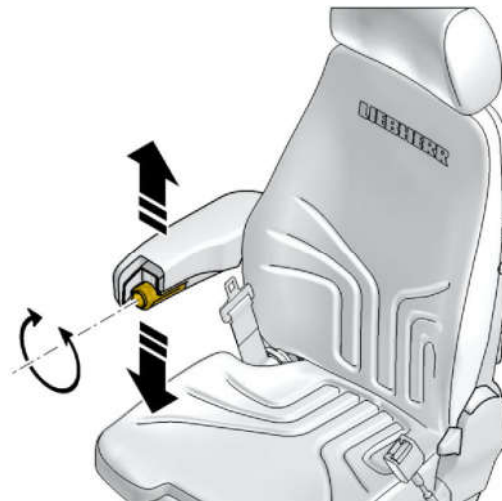
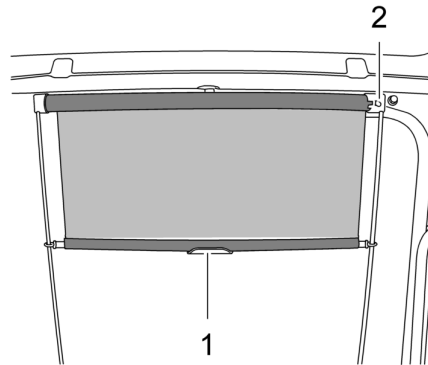

Fig. 278: Sun blind on windscreen

1 Tab

2 Roll up button

Rolling out sun blind on the windscreen

- ▶ Pull sun blind on windscreen down to desired position using tab 1.

Rolling up sun blind on the windscreen

- ▶ Push roll up button 2 upwards.

Sun blind on the roof glass panel

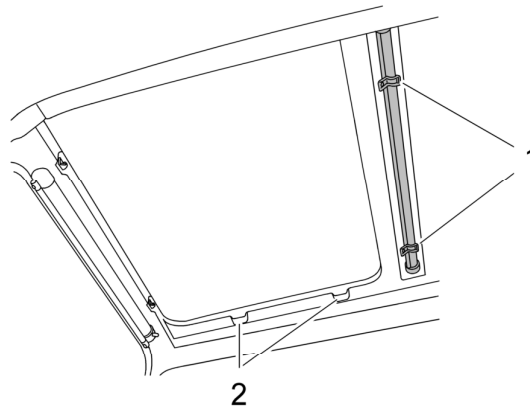

Fig. 279: Sun blind on the roof glass panel

1 Handle

2 Groove

Rolling out sun blind on the roof glass panel

- ▶ Pull sun blind forward on the roof glass panel using handles 1.
- ▶ Clip sun blind into grooves 2 on the roof glass panel.

3.3.16 Cab lighting system

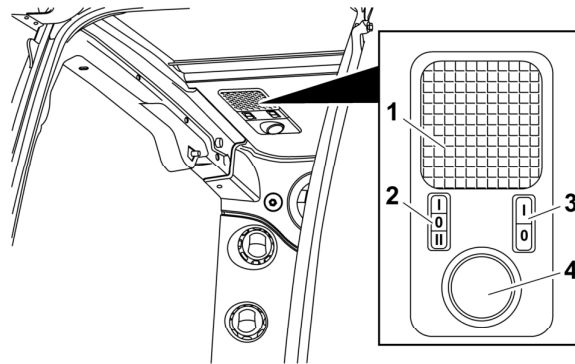

Fig. 300: Cab lighting system

- | | | | |
|---|--------------------------------|---|-------------------------|
| 1 | Cab lighting system | 3 | Switch for reading lamp |
| 2 | Switch for cab lighting system | 4 | Reading lamp |



Note

Discharged battery.

- ▶ Make sure that cab lighting system and reading lamp are switched off when exiting machine.

Cab lighting system

- ▶ Make sure that ignition key is set to 1.
- ▶ Switch on cab lighting system: Set switch for cab lighting system 2 to I.
- ▶ Switch off cab lighting system: Set switch for cab lighting system 2 to 0.



Cab lighting system for entry and exit

The cab lighting system for entry and exit is independent of the position of the ignition key.

- ▶ Switch on cab lighting system: Set switch for cab lighting system 2 to II.
 - ▷ Cab lighting system switches on automatically when cab door is opened.
 - ▷ Cab lighting system switches off automatically when cab door is closed.
- ▶ Switch off cab lighting system: Set switch for cab lighting system 2 to 0.

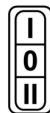

Reading lamp

- ▶ Make sure that ignition key is set to 1.
- ▶ Switch on reading lamp: Set switch for reading lamp 3 to I.
- ▶ Switch off reading lamp: Set switch for reading lamp 3 to 0.



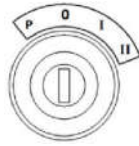

- ▶ Warn bystanders before starting machine: Activate horn. (For more information see: [3.3.9 Horn, page 115](#))
- ▶ Set ignition key to I.
 - ▷ Autocheck begins.
 - ▷ All LEDs briefly light up.
- ▶ During autocheck, check that the LEDs are functioning correctly.

If LEDs are defective:

- ▶ Have LEDs replaced.
- ▶ Press *START STOP* key for about half a second.
 - ▷ During starting of diesel engine, LEDs in *START STOP* key flash.
 - ▷ LEDs in *START STOP* key light up as soon as diesel engine has started.



Troubleshooting

Diesel engine does not start?

Starting the diesel engine ends automatically after 30 seconds. Starting can be extended beyond 30 seconds by pressing and holding *START STOP* key while starting. If two attempts to start fail, there is probably a malfunction of the diesel engine.

- ▶ Wait for at least 1 minute before the next attempt to start the diesel engine.
 - ▶ Press *START STOP* key and keep it pressed continuously while starting.
 - ▶ If there are two unsuccessful attempts to start the diesel engine, establish the cause of the fault and eliminate it.
-

Starting at low temperatures

At low outside temperatures, preglowing of the diesel engine is activated.



Engine preglowing activated status symbol appears on the display during preglowing of diesel engine.

When preglowing of the diesel engine is in progress:

- ▶ Do not start diesel engine.

When preglowing of diesel engine has finished:

- ▶ Start diesel engine.

Starting at temperatures below - °F

- ▶ Equip machine with one or more starting aids optionally available from Liebherr.

3.4.9 Bringing machine to operating temperature

Make sure the following preconditions are met:

- Hydraulic oil is approved for ambient temperature range. (For more information see: [5.3.8 Hydraulic oils, page 259](#))
- ▶ Move safety lever up.
- ▶ Start diesel engine and run at idle speed for 15 seconds.
- ▶ Move safety lever down.
- ▶ Set engine speed no higher than half the maximum engine speed.

CLICK HERE TO **DOWNLOAD** THE COMPLETE MANUAL

- Thank you very much for reading the preview of the manual.
- You can download the complete manual from: www.heydownloads.com by clicking the link below



- Please note: If there is no response to CLICKING the link, please download this PDF first and then click on it.

CLICK HERE TO **DOWNLOAD** THE COMPLETE MANUAL

3.4.16 Travel alarm (option)

The travel alarm is an acoustic warning signal. It sounds outside the machine.

Activating travel alarm

The travel alarm is activated automatically at the start of travel.

- ▶ Check whether travel alarm functions: Slightly depress one travelling pedal before driving.

Adjusting period for deactivating travel alarm

- ▶ Set period for deactivating travel alarm to between 5 seconds and 20 seconds: Contact Liebherr customer service.

Deactivating travel alarm

Depending on machine confirmation travel alarm can be deactivated.

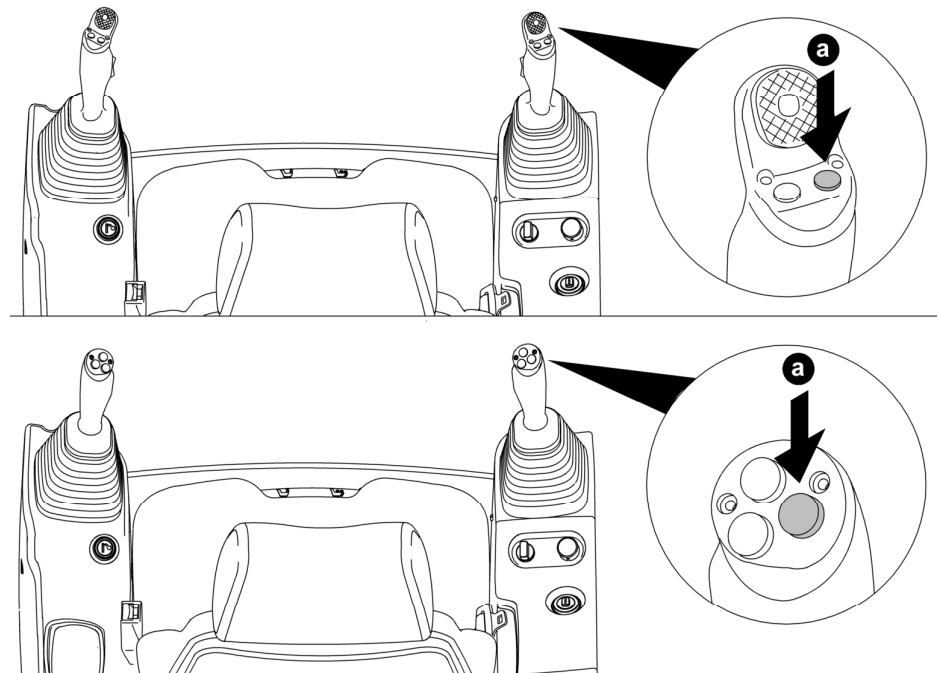

Fig. 346: Deactivating travel alarm

- ▶ Wait 10 seconds after activation of the travel alarm.
- ▶ Press the right button of the right joystick.

3.4.17 Controlling the working attachment

An information sticker on the side window of the operator's cab explains the operating principle of the controls.

The controls described below meet the **ISO standard for controllers** and are part of the standard equipment of the machine.

Retracting cylinder of the special working attachment

- ▶ Press pedal a.
- or

When first special working attachment is available on machine:
Press pedal c.

Extending cylinder of special working attachment

- ▶ Press pedal b.
- or

When first special working attachment is available on machine:
Press pedal d.

Controlling hydraulic hammer

- ▶ Press pedal a.
- or

When first special working attachment is available on machine:
Press pedal d.

Controlling flap of the bottom dump shovel

- ▶ Close flap of the bottom dump shovel: Press pedal c.
- ▶ Open flap of the bottom dump shovel: Press pedal d.

Controlling special working attachment with left joystick

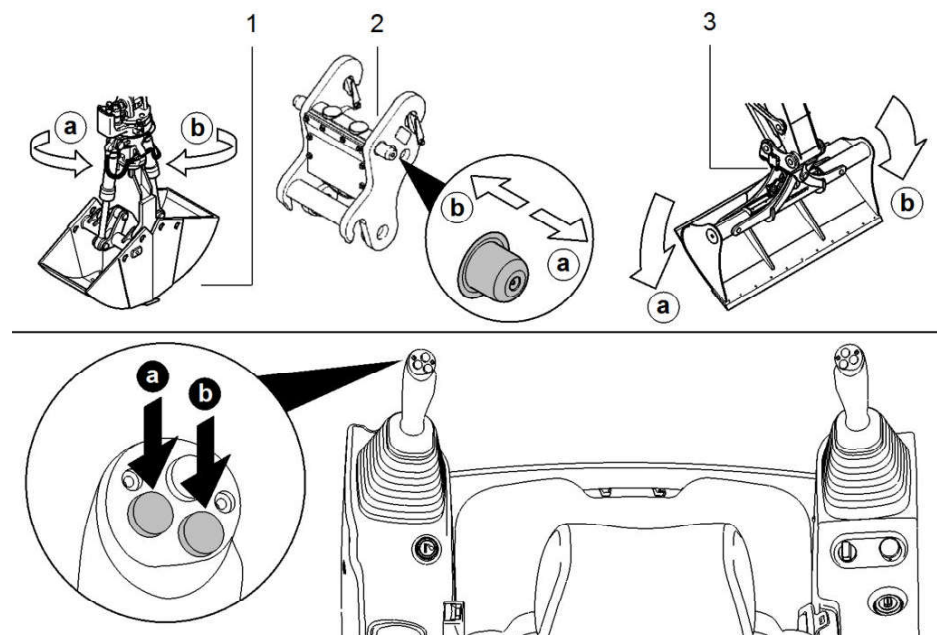

Fig. 376: Controlling special working attachment with left joystick

- | | | | |
|---|------------------------------|---|----------------------------------|
| 1 | Grapple with rotary actuator | 3 | Swivelling ditch-cleaning-bucket |
| 2 | Hydraulic quick coupler | | |

3.4.28 Changing over control of joystick control (option)

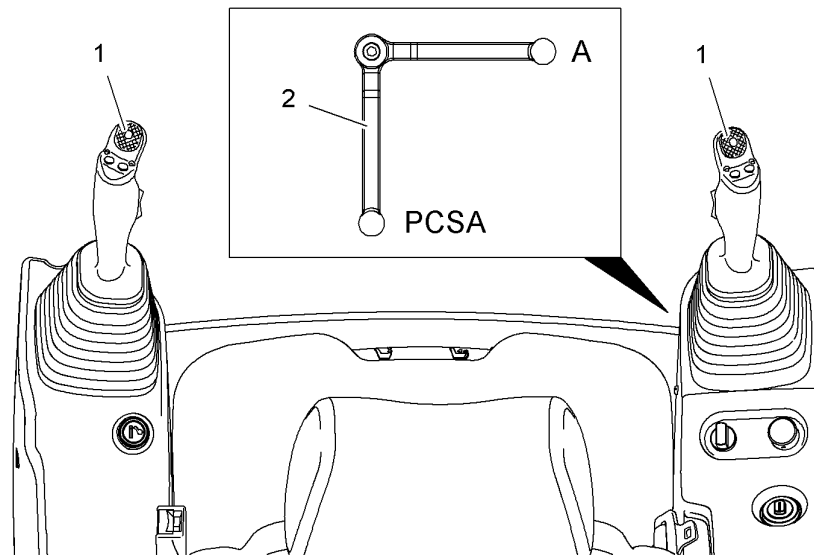

Fig. 407: Control changeover

1 Joystick

2 Changeover lever

The changeover lever 2 is on floor of operator's cab.



DANGER

Use of incorrect control!
Danger to life.

- ▶ Before working with machine, check function of controls.

Make sure the following preconditions are met:

- Joysticks are not actuated.
- ▶ Activate control changeover: Move changeover lever 2 to position A.
 - ▷ Function of joysticks 1 corresponds to *SPECIAL CONTROL* information sign. Information sign is affixed on side window of operator's cab.
- ▶ Deactivate control changeover: Move changeover lever 2 to position PCSA.

3.4.29 Grapple priority (option)

If the grapple is supplied via the high pressure circuit (for example, a grapple with Likufix hydraulic coupling system), three different priority modes can be set for supplying the grapple.

These modes are suitable for jobs where an object has to be picked up and the grapple is held at the stop while, at the same time, the working attachment is operated or travelling movements are completed.

3.6.2 Putting machine in working position

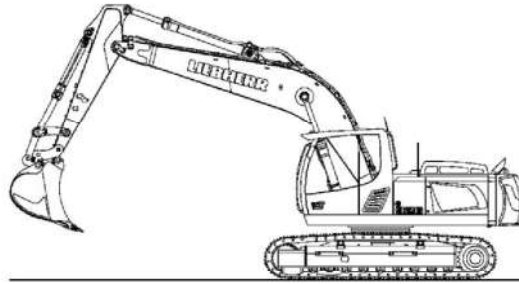

Fig. 439: Putting machine in working position

- ▶ Position machine on level and firm ground.
- ▶ Position working attachment above idler-wheel.

3.6.3 Travelling on slopes

Maximum inclination angle when travelling is 35°.

Maximum inclination angle when travelling applies exclusively if all the following conditions are met:

- Machine moves in a straight line to the slope.
- Uppercarriage is aligned parallel to undercarriage.
- Ground has suitable grip and strength.
- Machine is standard version with standard working attachment.
- Sprocket wheels are at back of the machine.

During travel on slope, travel position of working attachment does not match the position described in "travelling" chapter and working tool can block the view.



DANGER

Machine tipping over!
Danger to life.

- ▶ Adhere to maximum inclination angle during travel.

Make sure the following preconditions are met:

- Automatic uppercarriage locking is activated. (For more information see: [Automatic locking, page 152](#))

- ▶ Make sure that rigger leaves the danger zone after attaching and releasing of load.
- ▶ Exclusively raise and lower loads vertically.
- ▶ Move loads close to the ground.

3.6.14 Lifting loads with quick coupler

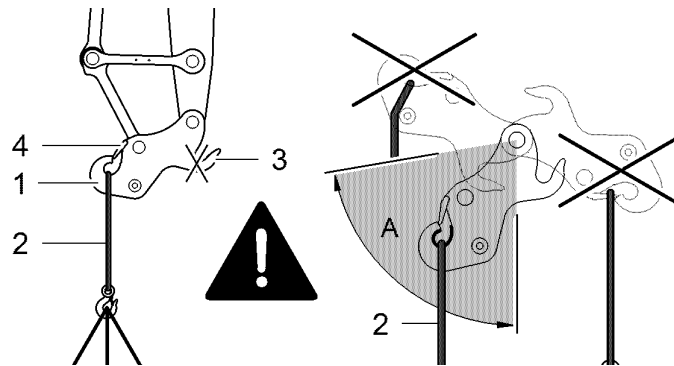

Fig. 449: Lifting loads with quick coupler

- | | | | |
|---|-------------------------------|---|-------------------------|
| 1 | Load hook | 4 | Safety flap |
| 2 | Lifting accessory | A | Permitted slewing range |
| 3 | Pick-up hook for working tool | | |

The quick coupler has two load lift hooks **1** for load-lifting work.

The maximum load capacity value of each load lift hook **1** is specified on the quick coupler.

Preparing load-lifting work

- ▶ Remove working tool from quick coupler and secure it.
- ▶ Fully retract locking pin.
- ▶ Align opening of the load lift hooks **1** upward.
- ▶ Check function of the safety flaps **4**.

Lifting loads



DANGER

Machine tipping over or falling loads!
Danger to life.

- ▶ Make sure that no-one is in danger zone.
- ▶ Have load-lifting work carried out exclusively by trained personnel.
- ▶ Exclusively move quick coupler within the permitted slewing range **A**.

- ▶ Exclusively attach loads to load lift hooks **1**.
- ▶ Do not put load on safety flaps **4**.
- ▶ Observe maximum load lift of the load lift hooks **1**.
- ▶ Observe load lift chart in the operator's cab.
- ▶ Lift loads safely. (For more information see: [3.6.13 Lifting loads, page 188](#))

3.8 Parking machine

**DANGER**

Machine tipping over!
Danger to life.

- ▶ Make sure that ground has suitable grip and firmness.

**Note**

Battery discharges during longer downtime.

- ▶ Check charging state of battery.

**Note**

- ▶ Exclusively park machine on slope as an exception.

3.8.1 Parking machine on level ground

If ambient temperature is below 32 °F:

- ▶ Avoid freezing onto the ground: Park machine on boards.
- ▶ Turn operator's cab over idler-wheels.
- ▶ Align uppercarriage parallel to undercarriage.
- ▶ Lock slewing brake.
- ▶ Lower working attachment to the ground.
- ▶ Shut off diesel engine.
- ▶ Make sure that ignition key is set to I.
- ▶ Make sure that safety lever or folding console is moved down.
- ▶ Depressurise hydraulic system: Operate joysticks and pedals carefully in all directions.
- ▶ Move safety lever or folding console up.
- ▶ Pull out ignition key.
- ▶ Lock all doors and flaps and remove key.

If machine will not be used for a long time:

- ▶ Set battery main switch to 0.

Positioning machine on low-loader

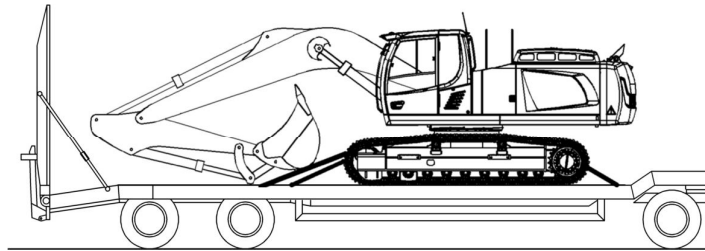

Fig. 473: Positioning machine on low-loader

Positioning uppercarriage

- ▶ Turn uppercarriage 180°.

Positioning standard attachment

- ▶ Lower attachment to low-loader platform.
- ▶ Retract stick to maximum: Deactivate stick cylinder protection. (For more information see: [3.4.21 Stick cylinder protection, page 156](#))

Positioning Multi-User attachment

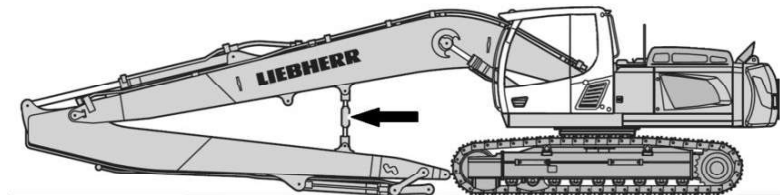

Fig. 474: Securing Multi-User attachment

- ▶ Retract Multi-User attachment without fully extending stick cylinder.
- ▶ Lower Multi-User attachment to low-loader platform.
- ▶ Secure stick with adjustable locking bars on the boom.
- ▶ Secure whole unit with cotter pins.

Preparing machine

- ▶ Depressurise hydraulic hoses. (For more information see: [5.10.1 Depressurising hydraulic system, page 304](#))
- ▶ Set ignition key to 0.
- ▶ Pull out ignition key.
- ▶ Pull up safety lever or folding console.
- ▶ Close and lock all doors, covers and hoods on the machine.
- ▶ Protect exhaust pipe of exhaust treatment system from rain and splashing water: Cover exhaust pipe.

Lowering operator's cab from operator's cab in an emergency

The emergency lowering stopcock in the operator's cab is on the ground to the right of the operator's seat.

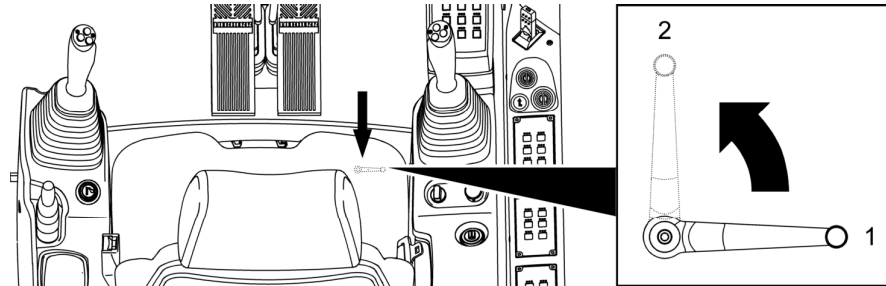

Fig. 494: Emergency lowering stopcock in operator's cab

Position of emergency lowering stopcock	Operator's cab
1	Normal operation
2	Emergency

Tab. 47: Position of emergency lowering stopcock

- ▶ Set emergency lowering stopcock to 2.
 - ▷ Operator's cab is lowered.

When operator's cab is fully lowered:

- ▶ Set emergency lowering stopcock to 1 again.
 - ▷ Operator's cab can be tilted.

Lowering operator's cab from uppercarriage in an emergency

The emergency lowering stopcock on the uppercarriage is behind the operator's cab.

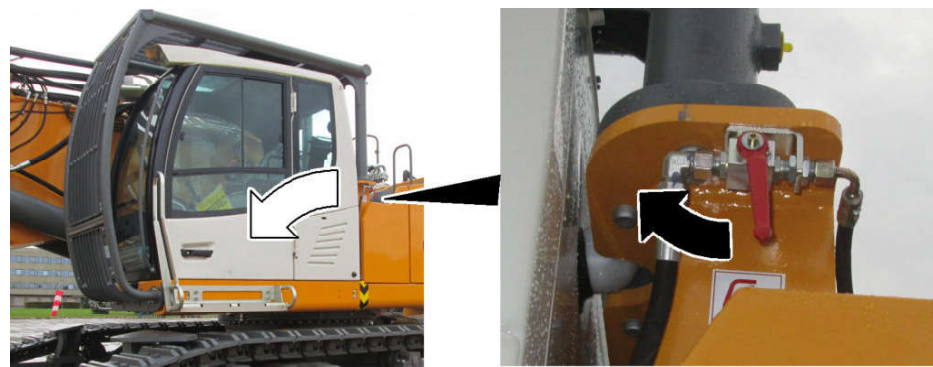

Fig. 495: Emergency lowering stopcock on uppercarriage

- ▶ Put emergency lowering stopcock in horizontal position.
 - ▷ Operator's cab is lowered.

4.2 Fault - Cause - Remedy

4.2.1 Diesel engine and fuel system

Malfunction / error	Cause	Remedy
Starter does not turn.	Main fuse defective	Replace fuse.
	Battery connections loose or corroded	Clean and secure battery connections.
	Battery voltage too low	Charge or replace the battery.
	Starter circuit discontinuity or contact corrosion	Contact Liebherr customer service.
	Starter defective	Contact Liebherr customer service.
Starter turns slowly.	Battery voltage too low	Charge or replace the battery.
	Battery connections loose or corroded	Clean and secure loose battery connections.
	Ambient temperature too low	Observe measures for winter operation.
Diesel engine does not start or stops immediately after start.	Fuel tank empty	Fill fuel tank. Bleed fuel system.
	Fuel fine filter clogged	Replace fuel fine filter.
	Fuel line, fuel pre-filter or screen plate of fuel tank clogged	Clean fuel line, fuel pre-filter or screen plate of fuel tank. Bleed fuel system.
	Fuel system or fuel fine filter leaking	Repair leaks and bleed fuel system.
	Air in fuel system	Bleed fuel system.
	Fuel not resistant to cold	Observe measures for winter operation.
	Ambient temperature too low	Comply with instructions on starting at low outside temperatures.
	Heating flange defective (at cold temperatures)	Have heater flange checked and replaced if necessary.
Diesel engine has difficulty starting.	Leak or too low pressure in low pressure fuel system	Have leak test performed.
	Diesel engine compression too low	Contact Liebherr customer service.
	Heating flange defective (at cold temperatures)	Have heater flange checked and replaced if necessary.
	Fault in electronic components	Check error memory of diesel engine control unit. Contact Liebherr customer service.

LFR/11827505/01/2018-08-31/en

	Current value [A]	Function
F39	16	Reserve
F40	8	Reserve
F41	16	Reserve
F42	16	Reserve
F43	16	Reserve
F44	8	Reserve
F45	8	Reserve
F46	8	Reserve
F47	8	Reserve
F48	8	KL30 for diesel engine
F49	16	Auxiliary heater
F51		Auxiliary headlight on boom
F52		Auxiliary headlight on counterweight
F53		Reserve
F110	50	Diesel engine control unit
Relay		
K1A	8/15	Magnetic circuit
K1B	8/15	Magnetic circuit
K2A	8/15	Auxiliary heater/water pump
K2B	8/15	Auxiliary heater
K3	10/20	Horn
K4	10/20	Fuel pre-heating
K9A1	8	Servo control pressure in emergency mode
K9B1	8	Slewing brake in emergency mode
K10A	8/15	Auxiliary headlight on boom
K10B	8/15	Auxiliary headlight on stick
K11	8/15	SCR system
K12	8/15	SCR system

Tab. 50: Fuses and relays in electric cabinet E50

Main circuit board

The main circuit board is behind the operator's seat.

Customer:..... Machine type:..... Serial no.:..... Operating hours:..... Date:.....

Maintenance / inspection after service hours							Tasks to be performed				
On handover	All 8-10 h	All 50 h	All 500 h	All 1000 h	All 2000 h	Other intervals	Additional labelling	By maintenance staff	By authorised specialist staff	Confirm tasks	See page
								■ Once-only activity ● Repeat interval † If necessary ✱ Annually before the winter Additional labelling ††† Assistance required ‡ Have this task carried out exclusively by a certified electrician	□ Once-only activity ○ Repeat interval ✧ If necessary		
						○ ✧		Bypass filter (option): Replace filter cartridge. (For more information see: 5.3.8 Hydraulic oils, page 259)			
			○	○	○			Control oil unit: Replace filter cartridge.			
			○	○	○			Supply pump: Replace filter cartridge.			
			○	○	○			Hydraulic hammer return filter (option): Check degree of contamination, replace filter cartridge if necessary.			
			○	○	○			Hydraulic components: Checking mounting.			
				○	○			Hydraulic components: Check condition and tightness.			
		●	○	○	○			Hydraulic hoses: Check condition and tightness.			309
						○4000h		Hydraulic hoses: Renewing when using synthetic esters. At least every 4 years.			
Electrical system											
□			○	○	○			Checking internal and external lighting of the machine.			
			○	○	○			Battery: Check acid density and acid level in battery cells.			
			○	○	○			Batteries: Checking and cleaning wire terminals and terminal posts.			
			○	○	○			Batteries: Check condition and correct installation of degassing hoses.			
			○	○	○			Rotary connection: Maintain slip rings.			
□			○	○				Check entire electrical system and its components.			
Travel gearbox											
□			○	○	○			Travel gearbox: Check oil level and tightness.			
			□	○				If travelling proportion of machine is less than 20 % (12 % for undercarriage SHD): Travel gearbox: Change oil (at least every 2 years).			
			□	○	○			If travelling proportion of machine is greater than 20 % (12 % for undercarriage SHD) or in dust intensive applications: Travel gearbox: Change oil (at least every 2 years).			
				○	○			Hydraulic motor and travel gearbox: Check mounting.			
				○	○			Check function of brakes.			
Travel gear											
□	●	●	○	○	○			Checking track tension, tightening if required.			311
		●	○	○	○			Track pads and sprocket wheels: Check mounting.			315

LFR/11827505/01/2018-08-31/en

If coolants from other manufacturers are used, information on change intervals must be obtained from respective manufacturer or supplier.

5.3.8 Hydraulic oils

Liebherr recommendation

Ambient temperature	Description
	Liebherr mineral oil
59 to 131 °F	Liebherr Hydraulic Basic 100
50 to 113 °F	Liebherr Hydraulic Basic 68
-4 to 104 °F	Liebherr Hydraulic HVI
	Liebherr-PAO ²²⁾ biodegradable
-13 to 113 °F	Liebherr Hydraulic Plus
-40 to 86 °F	Liebherr Hydraulic Plus Arctic

Tab. 69: Liebherr recommendation

Minimum quality requirements

See global Liebherr specifications for products "GSP 10465804".

If hydraulic oils or filters from other manufacturers are used, information on change and replacement intervals must be obtained from respective manufacturer or supplier.

Oil analysis

		Dust intensive application	Normal application
Normal application (oil analysis optional)	Liebherr mineral oil	Every 250 h, at least once a year	Every 1000 h, at least once a year
	Liebherr Hydraulic Basic 68		
	Liebherr Hydraulic Basic 100		
	Liebherr Hydraulic HVI		
Bio application (oil analysis prescribed)	Liebherr-PAO biodegradable	Upon handover, then every 250 h, at least once a year	Upon handover, then every 1000 h, at least once a year
	Liebherr Hydraulic Plus		
	Liebherr Hydraulic Plus Arctic		

Tab. 70: Oil analysis

²²⁾ PAO = poly-alpha-olefin

5.6 General maintenance

5.6.1 Welding

Welding on any main load-bearing or power-transmitting components must only be done by the manufacturer or a dealership authorised by the manufacturer. This applies irrespective of the welding process and the scope of the repair required.

NOTICE

Heating by powerful welding currents!
Bearings and sealing elements can burn.

- ▶ Attach the earth cable of the welding equipment close to the welding point.
 - ▶ Avoid electrical current flowing through electronic components and parts such as the slewing ring, joints, bearings, bushings, rubber elements or seals.
-

Before starting electric welding:

- ▶ Switch off the battery main switch.
- ▶ Disconnect the negative (-) terminal on the battery.
- ▶ Disconnect the electronic components.

After electric welding:

- ▶ Connect the electronic components.
- ▶ Connect the negative (-) terminal on the battery.
- ▶ Switch on the battery main switch.

5.6.2 Bleeding hydraulic cylinders

Cylinders must be bled in following cases:

- After maintenance work on cylinder
- After replacing cylinder
- After maintenance work on hydraulic system for supplying cylinder, for example after replacing a hose

Bleeding hydraulic cylinder with vent plugs

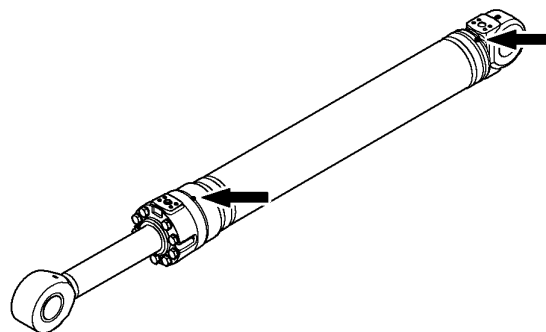

Fig. 581: Vent plugs of cylinder

Pre-treatment	Clean completely with high-pressure cleaner (with cleaning agent) and then rinse with clear water (no salt water or similar).					
	Clean and decrease with solvent (caution with seals and other sensitive synthetic components). If necessary clean with dry and oil-free compressed air. If necessary remove defective seals (acrylic sealing material) and traces of oxidation. Remove non-adherent paint. Grind oxidised surfaces with abrasive paper (grain P60-120) or mechanically with appropriate tool.					
Conservation	Product	Thickness	Product	Thickness	Product	Thickness
	WAXOYL 120.4	50 µm	DENSO TAPE	-	LPS 1	2 µm
	Colour		Colour		Colour	
	Orange		Brown		Transparent	

Tab. 86: Machine used in maritime climate, on coasts, in ports or in chemically aggressive environment

Recommended conservation products

Designation	Item code	Container	Disposal
TOP WAX 6	10218690	1.32 gal	A protective layer of TOP WAX 6 can be removed with a high-pressure cleaner and warm water or with solvent (for example: White Spirit).
Properties			Remarks
TOP WAX 6 forms a non-permanent translucent conservation layer that is easy to apply thanks to the low viscosity. The product makes the treated surfaces water-repellent and forms a temporary thin protective layer that does not change the appearance of the treated surface. The product easily penetrates gaps and displaces humidity.			TOP WAX 6 can be applied with a brush and paint-brush. It can also be applied with a cup spray gun or a manual pulveriser. The drying time is 10 to 20 minutes. Shake can thoroughly before use.
Designation	Item code	Container	Disposal
WAXOYL 120.4	8504314	1.32 gal	A protective layer of WAXOYL 120.4 can exclusively be removed with solvent (for example: White Spirit).
	8504472	Aerosol	
Properties			Remarks
WAXOYL 120.4 enables long-term conservation with a thick coat. This product contains highly effective corrosion-inhibiting substances. It is particularly suited for treating hollow spaces. In spite of its high viscosity the product spreads well and forms a homogeneous coat. The product easily penetrates gaps and displaces humidity. It forms a slightly tinted, opaque coat.			WAXOYL 120.4 can be applied with a brush, paint-brush and roller. It can be applied with airless equipment or a paint spray gun. It can be diluted with White Spirit. The drying time depends strongly on the ambient temperature. For example: dry to the touch after 2 hours at 68 °F
Designation	Item code	Container	Disposal

LFR/11827505/01/2018-08-31/en

Checking oil level on dipstick

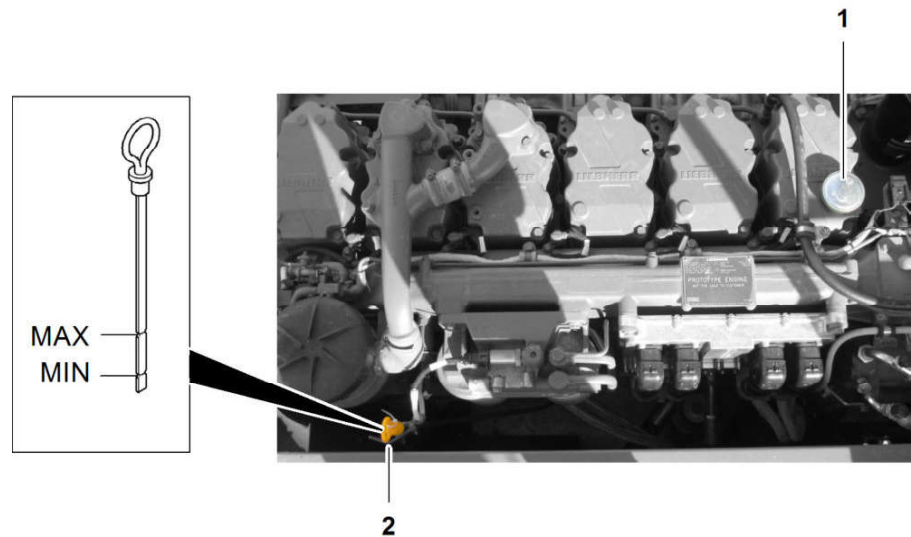

Fig. 592: Checking oil level on dipstick

1 Oil filling hole

2 Dipstick

Dipstick 2 and oil filling hole 1 are arranged differently according to diesel engine type.



WARNING

Hot engine oil!
Burns.

- ▶ Wear protective gloves.
- ▶ Avoid skin contact with hot engine oil and hot parts carrying oil.

Make sure the following preconditions are met:

- Diesel engine is in maintenance position. (For more information see: [5.8.1 Diesel engine: Putting in maintenance position, page 288](#))
- ▶ Pull out dipstick 2 and clean with clean lint-free cloth.
- ▶ Insert dipstick 2 fully.
- ▶ Pull out dipstick 2 again and check that oil level is between *MIN* mark and *MAX* mark.

If oil level is below *MIN* mark:

- ▶ Fill with oil. (For more information see: [Filling with oil, page 289](#))
- ▶ Put in dipstick 2.

Filling with oil



WARNING

Hot engine oil!
Burns.

- ▶ Wear protective gloves.
- ▶ Avoid skin contact with hot engine oil and hot parts carrying oil.

5.9 Cooling system

5.9.1 Checking coolant level

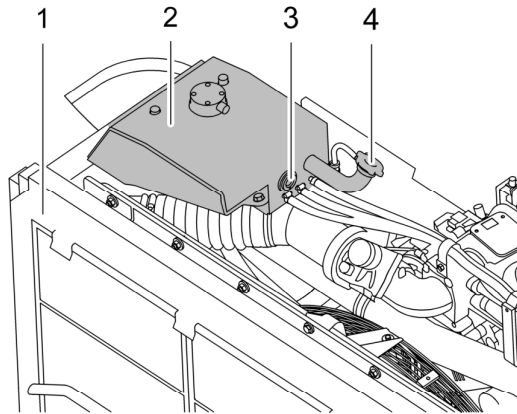

Fig. 619: Coolant container

- | | | | |
|---|-------------------|---|-------------|
| 1 | Radiator | 3 | Sight glass |
| 2 | Coolant container | 4 | Filler cap |

Checking coolant level



WARNING

Hot pressurised cooling system!
Burns.

- ▶ Let cooling system cool down.
 - ▶ Wear protective gloves and safety glasses.
 - ▶ Avoid skin contact with coolant.
 - ▶ Avoid contact with parts carrying coolant.
-
- ▶ Check whether sight glass **3** is completely filled with coolant.
- If sight glass **3** is not completely filled with coolant:
- ▶ Fill with coolant. (For more information see: [Filling with coolant, page 300](#))

Make sure the following preconditions are met:

- Diesel engine is idling.
- Hydraulic oil is at operating temperature.
- ▶ Check pressure on pressure gauge 1 of bypass filter.

If the displayed value is more than 36.26 psi:

- ▶ Have filter cartridge 4 of bypass filter replaced.

5.10.6 Hydraulic hoses: Checking condition and tightness

- ▶ Check condition and tightness of hydraulic hoses.

Damage includes:

- Cuts, cracks or abrasion points on outer layer of hydraulic hose that reach the inner layer
- Cracking caused by outer layer of hydraulic hose becoming brittle
- Deformations that do not correspond to normal shape of hydraulic hose (for example separation of layers or bubble formation)
- Deformation on hydraulic hose fitting
- Hydraulic hose slipping out of fitting
- Corrosion on hydraulic hose fitting

If hydraulic hoses are damaged or leaking:

- ▶ Have hydraulic hoses replaced by Liebherr customer service.

NOTICE

Missing or very worn teeth!
Damage to tooth adapters.

- ▶ Before working with bucket, make sure that every tooth adapter is equipped with tooth.
 - ▶ Before working, check wear of teeth.
-

Removing tooth

- ▶ Clean tooth **5** and mounting system.
- ▶ Remove protection plug **4**.
- ▶ Turn securing pin **3** with a square wrench approximately 30° towards tooth **5**.
 - ▷ Nose of securing pin **3** slips out of pin retention **2**.
- ▶ Use the hammer and punch to knock out securing pin **3**.
- ▶ Remove tooth **5**.
- ▶ Remove pin retention **2**.
- ▶ Clean tooth adapter **1**.
- ▶ Check tooth adapter **1** for wear.

If tooth adapter **1** is worn:

- ▶ Have tooth adapter **1** replaced.

Installing tooth

- ▶ Insert pin retention **2**.
- ▶ Place new tooth **5** on tooth adapter **1**.
- ▶ Push securing pin **3** all the way in.
- ▶ Turn securing pin **3** with a square wrench approximately 30° towards bucket.
 - ▷ Nose of securing pin **3** engages in pin retention **2**.
- ▶ Insert protection plug **4** onto head of securing pin **3**.

CLICK HERE TO **DOWNLOAD** THE COMPLETE MANUAL

- Thank you very much for reading the preview of the manual.
- You can download the complete manual from: www.heydownloads.com by clicking the link below



- Please note: If there is no response to CLICKING the link, please download this PDF first and then click on it.

CLICK HERE TO **DOWNLOAD** THE COMPLETE MANUAL