

en

Operator's manual

Hydraulic excavator

Document ID

	ORIGINAL OPERATOR'S MANUAL
Order number:	12201151
Issued:	2019-10-25
Version:	01
Author:	LFR / Technical Documentation Department

Product ID

Manufacturer:	Liebherr-France SAS
Type:	R 920 Compact
Type no.:	1705
From Serial no.:	43057

Contact

Liebherr-France SAS
2 avenue Joseph Rey, B.P. 90287
F – 68005 Colmar Cedex

CLICK HERE TO **DOWNLOAD** THE COMPLETE MANUAL

- Thank you very much for reading the preview of the manual.
- You can download the complete manual from: www.heydownloads.com by clicking the link below



- Please note: If there is no response to CLICKING the link, please download this PDF first and then click on it.

CLICK HERE TO **DOWNLOAD** THE COMPLETE MANUAL

3	Control and operation	59
3.1	Control and operating elements	59
3.1.1	Overview of operator's platform	59
3.1.2	Control unit A	60
3.1.3	Control unit B	61
3.1.4	Further control units	61
3.2	Display	62
3.2.1	Display	62
3.2.2	Status symbols	63
3.2.3	Start page menu	71
3.2.4	Camera menu	71
3.2.5	Automatic air conditioning	73
3.2.6	Operating status menu	77
3.2.7	Diesel particulate filter submenu (option)	77
3.2.8	Sensor-controlled low idle automatic and automatic engine stop submenu (option)	78
3.2.9	System settings menu	79
3.2.10	Operating hour meter and odometer submenu	80
3.2.11	Windscreen wiper interval submenu	80
3.2.12	Radio remote control submenu	81
3.2.13	Display settings submenu	82
3.2.14	Display brightness and display volume submenu	82
3.2.15	Camera image contrast submenu	83
3.2.16	Camera return time submenu	83
3.2.17	Regional settings and system parameters submenu	84
3.2.18	Unit selection submenu	84
3.2.19	System diagnosis submenu	85
3.2.20	Time zone submenu	85
3.2.21	Time format and date format submenu	86
3.2.22	Language selection submenu	86
3.2.23	Electrical outputs submenu	87
3.2.24	Electrical inputs submenu	88
3.2.25	Function settings menu	88
3.2.26	Central lubrication system submenu (option)	90
3.2.27	Maintenance submenu	90

1.1.3 Undercarriage

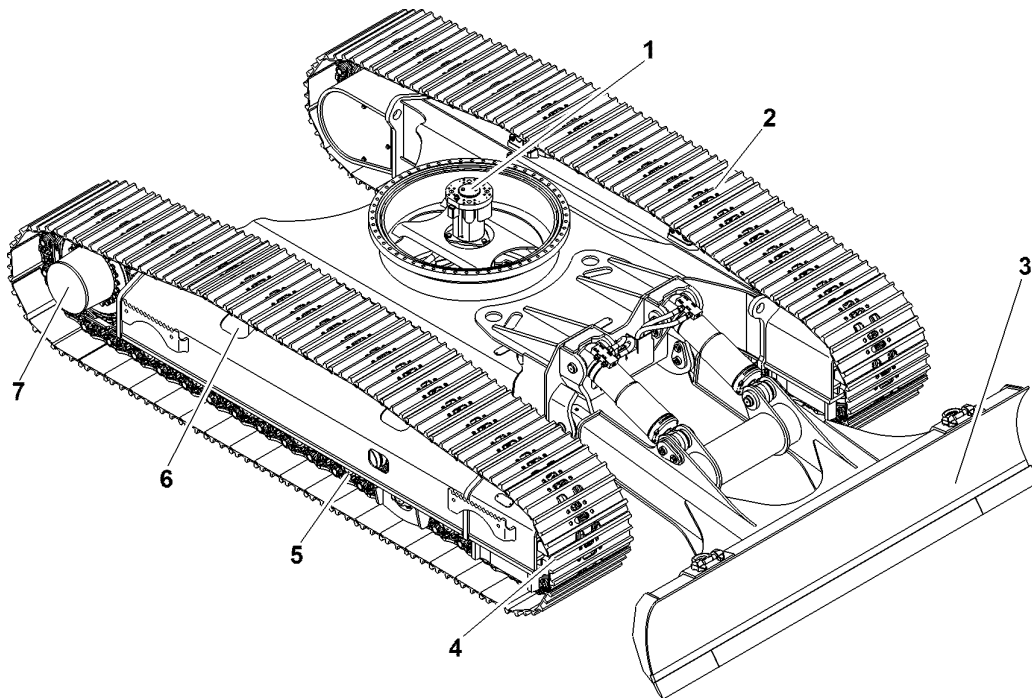

Fig. 4: Undercarriage

- | | | | | | |
|---|----------------------|---|----------------|---|------------------------------------|
| 1 | Rotary connection | 4 | Idler-wheel | 7 | Travel gearbox with sprocket wheel |
| 2 | Track | 5 | Track roller | | |
| 3 | Dozer blade (option) | 6 | Carrier roller | | |



Operator's Cab

Cab	ROPS safety cab structure (roll-over protection system) with individual windscreens or featuring a slide-in subpart under the ceiling, work headlights integrated in the ceiling, a door with a sliding window (can be opened on both sides), large stowing and depositing possibilities, shock-absorbing suspension, sound-damping insulating, tinted laminated safety glass, separate window shades for the sunroof window and windscreen, cigarette lighter and 12 V plug, storage bins, lunchbox, cup holder
Operator's seat	Liebherr-Comfort seat, airsprung with automatic weight adjustment, vertical and longitudinal seat damping including consoles and joysticks. Seat and armrests adjustable separately and in combination, seat heating as standard
Control system	joysticks with arm consoles and swivel seat
Operation and displays	large high-resolution operating unit, selfexplanatory, colour display with touchscreen, video-compatible, numerous setting, control and monitoring options, e.g. air conditioning control, fuel consumption, machine and tool parameters
Air-conditioning	automatic air-conditioning, recirculated air function, fast de-icing and demisting at the press of a button, air vents can be operated via a menu. Recirculated air and fresh air filters can be easily replaced and are accessible from the outside. Heating-cooling unit, designed for extreme outside temperatures, sensors for solar radiation, inside and outside temperatures (country-dependent) the air conditioning system contains fluorinated greenhouse gases
Refrigerant	R134a
Global warming potential	1,430
Quantity at 25 °C*	1,260 g
CO ₂ equivalent	1.80 t
Noise emission	
ISO 6396	L _{pA} (inside cab) = 68 dB(A)
2000/14/EC	L _{WA} (surround noise) = 99 dB(A)
Vibration emission	
Hand/arm vibrations	< 2,5 m/s ² , according with ISO 5349-1:2001
Whole-body vibrations	conforms to technical report ISO/TR 25398:2006
Measuring inaccuracy	according with standard EN 12096:1997

* valid for standard machine without operator's cab elevation and without height adjustable cab

Undercarriage

Versions	
NLC	gauge 2,000 mm
LC	standard gauge 2,250 mm
Drive	Liebherr swashplate motors with integrated brake valves on both sides
Transmission	Liebherr compact planetary reduction gear
Travel speed	low range – 2.6 km/h high range – 5.7 km/h
Net drawbar pull on crawler	192 kN
Track components	B60, maintenance-free
Track rollers / Carrier rollers	7/2
Tracks	sealed and greased
Track pads	triple grouser
Holding brake	wet multi-disc (spring applied, pressure released)
Brake valves	integrated into travel motor
Lashing eyes	integrated



Attachment

Hydraulic cylinders	Liebherr cylinders with special seal-system, shock protection
Bearings	sealed, low maintenance
Lubrication	Liebherr central lubrication system

Lift Capacities

with Offset Two-Piece Boom 5.00 m and Counterweight 3.9 t

Stick 2.25 m

m	Under-carriage	3.0 m		4.5 m		6.0 m		7.5 m		m		
		LC	NLC	LC	NLC	LC	NLC	LC	NLC	LC	NLC	
7.5	NLC ¹⁾									3.5*	3.5*	4.3
	NLC with blade ¹⁾									3.5*	3.5*	
	LC									3.5*	3.5*	
	LC with blade									3.5*	3.5*	
6.0	NLC ¹⁾			5.2	5.8*					2.9*	2.9*	5.8
	NLC with blade ¹⁾			5.5	5.8*					2.9*	2.9*	
	LC			5.8*	5.8*					2.9*	2.9*	
	LC with blade			5.8*	5.8*					2.9*	2.9*	
4.5	NLC ¹⁾	8.3*	8.3*	5.1	6.3*	3.1	5.3*			2.5	2.7*	6.7
	NLC with blade ¹⁾	8.3*	8.3*	5.4	6.3*	3.4	5.3*			2.7	2.7*	
	LC	8.3*	8.3*	5.8	6.3*	3.6	5.3*			2.7*	2.7*	
	LC with blade	8.3*	8.3*	6.1	6.3*	3.9	5.3*			2.7*	2.7*	
3.0	NLC ¹⁾	8.8	10.5*	5.0	7.1*	3.1	5.3			2.1	2.7*	7.2
	NLC with blade ¹⁾	9.3	10.5*	5.3	7.1*	3.4	5.3			2.3	2.7*	
	LC	10.1	10.5*	5.6	7.1*	3.6	5.3			2.5	2.7*	
	LC with blade	10.5*	10.5*	6.0	7.1*	3.9	5.3			2.7*	2.7*	
1.5	NLC ¹⁾	8.7	11.3*	4.9	7.8	3.0	5.3			2.0	2.9*	7.3
	NLC with blade ¹⁾	9.2	11.3*	5.2	7.8*	3.3	5.3			2.2	2.9*	
	LC	10.0	11.3*	5.6	7.8*	3.5	5.3			2.4	2.9*	
	LC with blade	10.6	11.3*	5.9	7.8*	3.8	5.4			2.6	2.9*	
0	NLC ¹⁾	8.7	12.4*	4.7	7.8	2.8	5.1			2.0	3.2*	7.1
	NLC with blade ¹⁾	9.4	12.4*	5.1	7.9	3.1	5.2			2.2	3.2*	
	LC	10.2	12.4*	5.5	7.9	3.3	5.2			2.4	3.2*	
	LC with blade	10.8	12.4*	6.0	7.9*	3.6	5.3			2.7	3.2*	
-1.5	NLC ¹⁾	8.3	12.7*	4.4	8.2	2.7	4.9			2.3	3.8*	6.6
	NLC with blade ¹⁾	8.9	12.7*	4.7	8.2*	2.9	5.0			2.5	3.8*	
	LC	10.0	12.7*	5.2	8.2*	3.2	5.0			2.7	3.8*	
	LC with blade	10.8	12.7*	5.6	8.2*	3.5	5.1			3.0	3.8*	
-3.0	NLC ¹⁾	8.0	12.4*	4.1	6.8*					3.0	3.8*	5.4
	NLC with blade ¹⁾	8.6	12.4*	4.5	6.8*					3.3	3.8*	
	LC	9.7	12.4*	4.9	6.8*					3.6	3.8*	
	LC with blade	10.5	12.4*	5.3	6.8*					3.8*	3.8*	

Stick 2.45 m

m	Under-carriage	3.0 m		4.5 m		6.0 m		7.5 m		m		
		LC	NLC	LC	NLC	LC	NLC	LC	NLC	LC	NLC	
7.5	NLC ¹⁾									3.6*	3.6*	4.6
	NLC with blade ¹⁾									3.6*	3.6*	
	LC									3.6*	3.6*	
	LC with blade									3.6*	3.6*	
6.0	NLC ¹⁾			5.2	5.6*					3.1	3.2*	6.1
	NLC with blade ¹⁾			5.5	5.6*	3.2*	3.2*			2.6*	2.6*	
	LC			5.6*	5.6*	3.2*	3.2*			2.6*	2.6*	
	LC with blade			5.6*	5.6*	3.2*	3.2*			2.6*	2.6*	
4.5	NLC ¹⁾	7.1*	7.1*	5.1	6.1*	3.2	5.1*			2.3	2.5*	6.9
	NLC with blade ¹⁾	7.1*	7.1*	5.4	6.1*	3.4	5.1*			2.5*	2.5*	
	LC	7.1*	7.1*	5.8	6.1*	3.7	5.1*			2.5*	2.5*	
	LC with blade	7.1*	7.1*	6.1*	6.1*	4.0	5.1*			2.5*	2.5*	
3.0	NLC ¹⁾	8.8	10.5*	5.0	7.0*	3.2	5.3			2.0	2.5*	7.4
	NLC with blade ¹⁾	9.3	10.5*	5.3	7.0*	3.4	5.3			2.2	2.5*	
	LC	10.1	10.5*	5.6	7.0*	3.7	5.3			2.4	2.5*	
	LC with blade	10.5*	10.5*	6.0	7.0*	4.0	5.4			2.5*	2.5*	
1.5	NLC ¹⁾	8.6	11.2*	4.9	7.7*	3.1	5.2	1.9	2.8*	1.9	2.6*	7.5
	NLC with blade ¹⁾	9.1	11.2*	5.2	7.7*	3.3	5.3	2.1	2.8*	2.1	2.6*	
	LC	9.9	11.2*	5.6	7.7*	3.6	5.3	2.3	2.8*	2.3	2.6*	
	LC with blade	10.5	11.2*	5.9	7.7*	3.8	5.4	2.5	2.8*	2.5	2.6*	
0	NLC ¹⁾	8.8	12.3*	4.8	7.8	2.9	5.1			1.9	2.9*	7.3
	NLC with blade ¹⁾	9.3	12.3*	5.1	7.8	3.1	5.2			2.1	2.9*	
	LC	10.1	12.3*	5.6	7.9	3.4	5.2			2.3	2.9*	
	LC with blade	10.7	12.3*	6.0	7.9*	3.7	5.3			2.5	2.9*	
-1.5	NLC ¹⁾	8.3	12.6*	4.4	8.1*	2.7	4.9			2.1	3.4*	6.8
	NLC with blade ¹⁾	8.9	12.6*	4.8	8.1*	2.9	5.0			2.3	3.4*	
	LC	10.0	12.6*	5.2	8.1*	3.2	5.0			2.5	3.4*	
	LC with blade	10.8	12.6*	5.6	8.1*	3.5	5.1			2.8	3.4*	
-3.0	NLC ¹⁾	8.0	12.8*	4.1	7.3*					2.7	3.5*	5.8
	NLC with blade ¹⁾	8.7	12.8*	4.5	7.3*					3.0	3.5*	
	LC	9.7	12.8*	4.9	7.3*					3.2	3.5*	
	LC with blade	10.5	12.8*	5.3	7.3*					3.5*	3.5*	

Stick 2.65 m

m	Under-carriage	3.0 m		4.5 m		6.0 m		7.5 m		m		
		LC	NLC	LC	NLC	LC	NLC	LC	NLC	LC	NLC	
7.5	NLC ¹⁾			4.2*	4.2*					2.8*	2.8*	4.9
	NLC with blade ¹⁾			4.2*	4.2*					2.8*	2.8*	
	LC			4.2*	4.2*					2.8*	2.8*	
	LC with blade			4.2*	4.2*					2.8*	2.8*	
6.0	NLC ¹⁾			5.2	5.4*	3.1	3.8*			2.4*	2.4*	6.3
	NLC with blade ¹⁾			5.4*	5.4*	3.4	3.8*			2.4*	2.4*	
	LC			5.4*	5.4*	3.6	3.8*			2.4*	2.4*	
	LC with blade			5.4*	5.4*	3.8*	3.8*			2.4*	2.4*	
4.5	NLC ¹⁾	6.0*	6.0*	5.1	5.9*	3.2	5.0*			2.2	2.3*	7.1
	NLC with blade ¹⁾	6.0*	6.0*	5.4	5.9*	3.5	5.0*			2.3*	2.3*	
	LC	6.0*	6.0*	5.8	5.9*	3.7	5.0*			2.3*	2.3*	
	LC with blade	6.0*	6.0*	5.9*	5.9*	4.0	5.0*			2.3*	2.3*	
3.0	NLC ¹⁾	8.9	10.3*	5.0	6.8*	3.2	5.2	2.0	2.9*	1.9	2.2*	7.6
	NLC with blade ¹⁾	9.4	10.3*	5.3	6.8*	3.5	5.3	2.2	2.9*	2.1	2.2*	
	LC	10.2	10.3*	5.6	6.8*	3.7	5.3	2.3	2.9*	2.2*	2.2*	
	LC with blade	10.3*	10.3*	6.0	6.8*	4.0	5.3*	2.6	2.9*	2.2*	2.2*	
1.5	NLC ¹⁾	8.6	11.2*	4.9	7.6*	3.1	5.2	1.9	3.5	1.8	2.3*	7.7
	NLC with blade ¹⁾	9.1	11.2*	5.2	7.6*	3.3	5.3	2.1	3.6	2.0	2.3*	
	LC	9.9	11.2*	5.5	7.6*	3.6	5.3	2.3	3.6	2.2	2.3*	
	LC with blade	10.5	11.2*	5.9	7.6*	3.9	5.3	2.5	3.7	2.3*	2.3*	
0	NLC ¹⁾	8.7	12.1*	4.8	7.7	2.9	5.1	1.8	2.9*	1.8	2.6*	7.5
	NLC with blade ¹⁾	9.2	12.1*	5.1	7.8	3.2	5.2	2.0	2.9*	2.0	2.6*	
	LC	10.0	12.1*	5.6	7.8	3.4	5.2	2.2	2.9*	2.2	2.6*	
	LC with blade	10.6	12.1*	6.0	7.8*	3.7	5.3	2.4	2.9*	2.4	2.6*	
-1.5	NLC ¹⁾	8.3	12.5*	4.5	8.0	2.7	4.9			2.0	3.0*	7.0
	NLC with blade ¹⁾	8.9	12.5*	4.9	8.0	2.9	5.0			2.2	3.0*	
	LC	10.0	12.5*	5.3	8.0	3.2	5.0			2.4	3.0*	
	LC with blade	10.8	12.5*	5.7	8.0*	3.5	5.1			2.7	3.0*	
-3.0	NLC ¹⁾	8.1	13.1*	4.1	7.7*	2.6	3.7*			2.5	3.4*	6.1
	NLC with blade ¹⁾	8.7	13.1*	4.5	7.7*	2.8	3.7*			2.8	3.4*	
	LC	9.8	13.1*	4.9	7.7*	3.1	3.7*			3.0	3.4*	
	LC with blade	10.6	13.1*	5.3	7.7*	3.4	3.7*			3.3	3.4*	

 Height
  Can be slewed though 360°
  In longitudinal position of undercarriage
  Max. reach
 * Limited by hydr. capacity

The load values are quoted in tons (t) at stick end (without bucket), and may be swung 360° on firm and even ground. Adjacent values are valid for the undercarriage when in the longitudinal position. Capacities are valid for 600 mm wide track pads with adjusting cylinder in optimal position. Indicated loads are based on ISO 10567 standard and do not exceed 75% of tipping or 87% of hydraulic capacity (indicated via *). Without bucket cylinder, link and lever the lift capacities will increase by 230 kg. Lifting capacity of the excavator is limited by machine stability and hydraulic capacity.

According to European Standard, EN 474-5: In the European Union excavators have to be equipped with an overload warning device, a load diagram and automatic safety check valves on hoist cylinders and stick cylinder(s), when they are used for lifting operations which require the use of lifting accessories.

¹⁾ Values are calculated with 500 mm wide track pads for the NLC-Undercarriage



Operator's Cab

Cab	ROPS safety cab structure (roll-over protection system according to ISO 12117-2:2008) with windscreen, totally or partially retractable (only upper part), under cab roof, work headlights integrated in the ceiling, a door with a sliding window (can be opened on both sides), large storing box and several stowing possibilities, shock-absorbing suspension, laminated right hand side and roof windows, all windows tinted, separate extensible window shades for the sun-roof window and windscreen, cigarette lighter and 24 V plug, 12 V plug, cup holder
Operator's seat	Liebherr-Comfort seat, airsprung with automatic weight adjustment, vertical and longitudinal seat damping including consoles and joysticks. Seat and armrests adjustable separately and in combination (adjustable in width, height and inclination), seat heating as standard
Arm consoles	Oscillating consoles with seat, tiltable console left
Operation and displays	Large high-resolution operating unit, intuitive, colour display with touchscreen, video-compatible, numerous setting, control and monitoring options, e.g. air conditioning control, fuel consumption, machine and attachment parameters
Air-conditioning	Automatic air-conditioning, recirculated air function, fast de-icing and demisting at the press of a button, air vents can be operated via a menu. Recirculated air and fresh air filters can be easily replaced and are accessible from the outside. Heating-cooling unit, designed for extreme outside temperatures, sensors for solar radiation, inside and outside temperatures The air conditioning system contains fluorinated greenhouse gases
Refrigerant	R134a
Global warming potential	1,430
Quantity at 25 °C*	1,260 g
CO ₂ equivalent	1.80 t
Vibration emission**	
Hand/arm vibrations	< 2.5 m/s ² , according with ISO 5349-1:2001
Whole-body vibrations	< 0.5 m/s ²
Measuring inaccuracy	According with standard EN 12096:1997
Noise emission	
ISO 6396	L _{PA} (inside cab) = 68 dB(A)
2000/14/EC	L _{WA} (surround noise) = 102 dB(A)

Undercarriage

Versions	
NLC	Gauge 2,000 mm
LC	Standard gauge 2,250 mm
Drive	Liebherr swashplate motor with brake valves on both sides
Transmission	Liebherr compact planetary reduction gear
Maximum travel speed	Low range 2.6 km/h High range 5.7 km/h
Drawbar pull on crawler	192 kN
Track components	B60, maintenance-free
Track rollers/Carrier rollers	7/2
Tracks	Sealed and greased
Track pads	Triple grouser
Holding brake	Wet multi-disc (spring applied, pressure released)
Brake valves	Integrated into travel motor
Lashing eyes	Integrated



Equipment

Hydraulic cylinders	Liebherr cylinders with seal and guidance systems and shock protection
Bearings	Sealed, low maintenance
Lubrication	Liebherr central lubrication system

* Valid for standard machine without operator's cab elevation and without height adjustable cab

** For the risk assessment according to 2002/44/EC see ISO/TR 25398:2006

Buckets Machine stability per ISO 10567* (75% of tipping capacity)

	Cutting width mm	Capacity ISO 7451 m ³	Weight ³⁾ kg	NLC-Undercarriage (with track pads 500 mm)						NLC-Undercarriage with blade (with track pads 500 mm)						LC-Undercarriage (with track pads 600 mm)						LC-Undercarriage with blade (with track pads 600 mm)					
				Stick length (m)						Stick length (m)						Stick length (m)						Stick length (m)					
				without quick coupler			with quick coupler			without quick coupler			with quick coupler			without quick coupler			with quick coupler			without quick coupler			with quick coupler		
	2.25	2.45	2.65	2.25	2.45	2.65	2.25	2.45	2.65	2.25	2.45	2.65	2.25	2.45	2.65	2.25	2.45	2.65	2.25	2.45	2.65	2.25	2.45	2.65			
STD ¹⁾	500	0.30	290	▲	▲	▲	▲	▲	▲	▲	▲	▲	▲	▲	▲	▲	▲	▲	▲	▲	▲	▲	▲	▲	▲		
	650	0.42	350	▲	▲	▲	▲	▲	▲	▲	▲	▲	▲	▲	▲	▲	▲	▲	▲	▲	▲	▲	▲	▲	▲		
	850	0.60	400	▲	▲	▲	▲	▲	▲	▲	▲	▲	▲	▲	▲	▲	▲	▲	▲	▲	▲	▲	▲	▲	▲		
	1,050	0.80	480	▲	▲	■	▲	▲	■	▲	▲	▲	▲	▲	▲	▲	▲	▲	▲	▲	▲	▲	▲	▲	▲		
	1,250	0.95	525	■	▲	■	▲	▲	■	▲	■	■	▲	■	▲	▲	▲	▲	▲	■	▲	▲	▲	▲	▲		
HD ²⁾	500	0.30	320	▲	▲	▲	▲	▲	▲	▲	▲	▲	▲	▲	▲	▲	▲	▲	▲	▲	▲	▲	▲	▲	▲		
	650	0.42	390	▲	▲	▲	▲	▲	▲	▲	▲	▲	▲	▲	▲	▲	▲	▲	▲	▲	▲	▲	▲	▲	▲		
	850	0.60	450	▲	▲	▲	▲	▲	▲	▲	▲	▲	▲	▲	▲	▲	▲	▲	▲	▲	▲	▲	▲	▲	▲		
	1,050	0.80	540	▲	▲	■	▲	■	■	▲	▲	▲	▲	▲	▲	▲	▲	▲	▲	▲	▲	▲	▲	▲	▲		
	1,250	0.95	595	▲	▲	■	▲	■	■	▲	■	■	▲	■	■	▲	▲	▲	■	▲	▲	▲	▲	▲	▲		

* Indicated loads are based on ISO 10567, at maximum reach, and may be swung 360° on firm and even ground

¹⁾ Standard bucket with teeth Uni 35-3

²⁾ HD bucket with teeth Uni 35-3

³⁾ Bucket for direct mounting or mounting to quick coupler

Other buckets available upon request

Max. material weight ▲ = ≤ 2.0 t/m³, ■ = ≤ 1.8 t/m³, ▲ = ≤ 1.65 t/m³, ■ = ≤ 1.5 t/m³

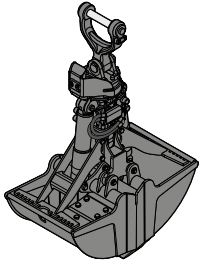

Clamshells

GMZ 22, earthmoving shell, for mounting to quick coupler SWA 33

Cutting width	mm	600	800	1,000
Capacity	m ³	0.30	0.42	0.54
Weight	kg	860	930	1,000

GMZ 24, earthmoving shell, for mounting to quick coupler SWA 48

Cutting width	mm	600	800	1,000
Capacity	m ³	0.34	0.46	0.60
Weight	kg	890	970	1,040

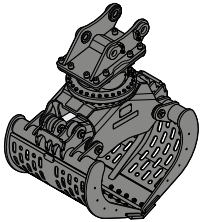

Sorting Grab

ribbed

perforated

closed

stone tong

SG 20B, for mounting to quick coupler SWA 33

Cutting width	mm				800	1,000	1,200	800	1,000	1,200	
Capacity	m ³				0.40	0.50	0.60	0.40	0.50	0.60	
Weight	kg				750	795	840	765	810	850	

SG 20B, for mounting to quick coupler SWA 48

Cutting width	mm				800	1,000	1,200	800	1,000	1,200	
Capacity	m ³				0.40	0.50	0.60	0.40	0.50	0.60	
Weight	kg				750	795	840	765	810	850	

SG 25, for mounting to quick coupler SWA 33

Cutting width	mm	800	1,000	1,200	800	1,000	1,200	800	1,000	1,200	800
Capacity	m ³	0.50	0.65	0.80	0.55	0.75	0.90	0.55	0.75	0.90	0.55
Weight	kg	1,225	1,310	1,400	1,180	1,245	1,310	1,200	1,270	1,340	1,365

SG 25, for mounting to quick coupler SWA 48

Cutting width	mm	800	1,000	1,200	800	1,000	1,200	800	1,000	1,200	800
Capacity	m ³	0.50	0.65	0.80	0.55	0.75	0.90	0.55	0.75	0.90	0.55
Weight	kg	1,225	1,310	1,400	1,180	1,245	1,310	1,200	1,270	1,340	1,365

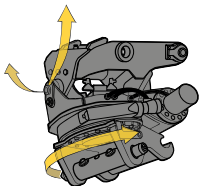

Tiltrotator

LH-TR 20, for mounting to quick coupler SWA 33

Weight	kg	470
Rotation		360°
Tilt		2 x 50°

- Adhere to safety regulations at place of use.
- Report all changes to machine that affect safety to operating company.
- If it is no longer possible to work safely: Immediately stop operating machine.
- Exclusively perform retrofittings of machine after consultation with manufacturer.
- Use original Liebherr spare parts wherever possible.

Requirement

The operator has following qualification and skills:

- Has completed the legally specified minimum age.
- Is physically and mentally capable of operating the machine safely.
 - Satisfactory eyesight
 - Satisfactory hearing ability
 - Quick reactions
 - Is able to estimate distance, height and gaps.
- Has the necessary authorisation for operation of machine.
- The operator has the necessary education (theoretical and practical) for the following:
 - Handling the machine type
 - Attaching
 - Spotting
 - Handling fire extinguishing equipment
- Knows all means of escape in an emergency.
- Is not under any physical or mental impairment that limits one of the prescribed requirements.
- Is not under the influence of alcohol.
- Is not under the influence of drugs.

2.3.5 Maintenance staff

Responsibility



The maintenance staff are responsible for the following:

- Read operator's manual.
- Read supplied documentation.
 - Operator's manuals for components
 - Operator's manuals from third party manufacturers
 - Additional instructions
- Maintain machine for safe and reliable function.
- Execute all maintenance tasks specified for maintenance staff in the maintenance and inspection schedule.
- Wear personal protective equipment.
- Adhere to safety regulations at place of use.
- Report all changes to machine that affect safety to operating company.
- Exclusively perform retrofittings of machine after consultation with manufacturer.
- Use original Liebherr spare parts wherever possible.

Requirement

The maintenance staff has following qualification and skills:

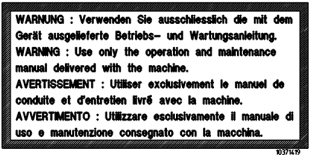
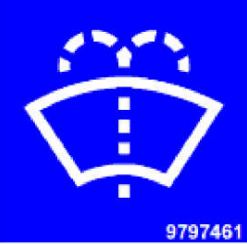
- Has completed the legally specified minimum age.
- Is physically and mentally capable of maintaining the machine.
 - Satisfactory eyesight
 - Satisfactory hearing ability
 - Quick reactions
 - Is able to estimate distance, height and gaps.

	Sign	Description
40		<p>Roll over protective structure (ROPS)</p> <p>Indicates that modifications or repairs on the roll over protective structure (ROPS) are strictly prohibited. For more information see operator's manual.</p>
41		<p>Operator's manual</p> <p>Exclusively use operator's manual supplied with machine.</p>
42		<p>Windscreen washer tank</p> <p>Shows position of the windscreen washer tank.</p>
43		<p>Diesel exhaust fluid tank</p> <p>Fill diesel exhaust fluid tank exclusively with diesel exhaust fluid in line with ISO 22241. For more information on filling diesel exhaust fluid tank with diesel exhaust fluid, see operator's manual.</p>
44		<p>Coolant</p> <p>Shows that the cooling system is filled with Liebherr Antifreeze OS coolant. For more information see operator's manual.</p>

LFR/1220115/01/2019-10-25/en

2.7.8 Operation of machine

Danger to life

Incorrect place of use

- Make sure that load capacity value of ground is sufficient.
- Do not exceed maximum inclination angle of machine while working.
- Do not exceed maximum inclination angle of machine when driving on ramps (side inclination).
- Make sure that ground offers sufficient grip.
- Adhere to safety gap from live overhead cables.

Incorrect use

- When working in following areas, adhere to the laws, regulations and rules applicable at the place of use.
 - Explosive area
 - Flammable area
 - Areas with underground lines (gas, electricity)
- Make sure that machine is equipped with components for exhaust gas reduction when in closed spaces (for example tunnel, hall) in non-explosive environment.
- Clean machine regularly to remove flammable residues (for example dust, wood scraps).

Incorrect handling of electrical system

- Make sure there are no persons with a pacemaker in the vicinity of the running diesel engine.
- Before working on electrical system, make sure that affected parts are voltage-free.
- Before working on electrical system, make sure that neighbouring parts are isolated.
- Have work on electrical systems performed exclusively by a qualified electrician.

Injuries

Incorrect protection

- If there is a risk of falling objects (particularly during log clamp operation): Exclusively use machines with suitable protective structures.
- If there is a risk of objects penetrating the operator's cab (particularly during log clamp operation): Exclusively use machines with suitable protective structures.
- If machine is used in toxic environment: Insert filters approved for the use in air conditioning.
- If machine is used in dust-intensive environment: Insert filters approved for the use in air conditioning.

Incorrect refuelling

- Do not touch fuels with your skin.
- Do not inhale fuel vapours.

Selecting menu via menu bar

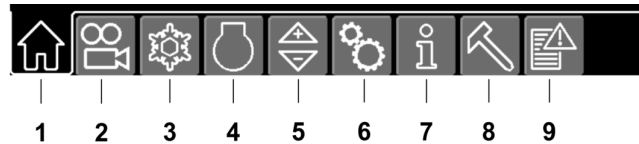

Fig. 51: Menu bar

- | | | | |
|---|--|---|-------------------------------|
| 1 | Start page menu button | 6 | Function settings menu button |
| 2 | Camera menu button ²⁾ | 7 | Information menu button |
| 3 | Automatic heating, automatic ventilation and automatic air conditioning system menu button | 8 | Tool Control menu button |
| 4 | Operating status menu button | 9 | Service codes menu button |
| 5 | System settings menu button | | |

- ▶ Press menu button in menu bar.
 - ▷ Symbol of selected menu has a black background.

Selecting menu via programmable keys

Programming key

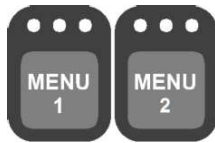

- ▶ Select menu: Press menu button in menu bar.
- ▶ Press *MENU 1* key or *MENU 2* key until middle and right LEDs light up.
- ▶ Release key/button.
 - ▷ Left LED lights up.
 - ▷ Menu is saved to key.

Selecting menu via key

- ▶ Press *MENU 1* key or *MENU 2* key.
 - ▷ Menu appears on the display.

3.2.2 Status symbols

The symbols in the status bar indicate the operating status. The displayed symbols depend on model and equipment of machine.

General symbols

Symbol	Meaning
	Confirmation required; press confirmation button.
	Confirmation error; press confirmation button.

²⁾ not valid for Rail machines.

Checking layout of camera images

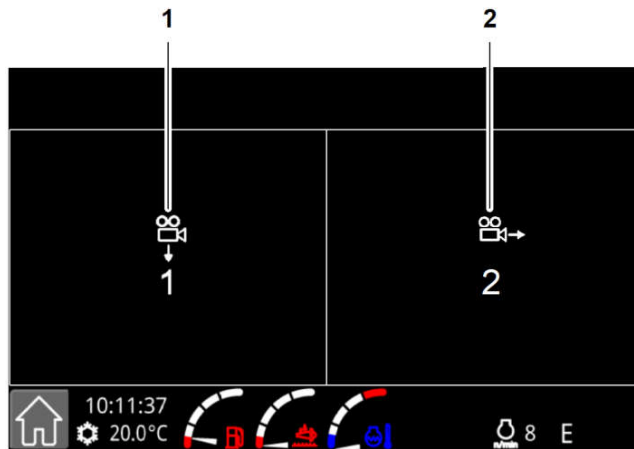



Fig. 141: Checking layout of camera images

- 1 Rear area camera symbol
- 2 Side area camera symbol

► Touch camera image on display.

3.2.5 Automatic air conditioning

Menu call: 

The cooling function is guaranteed exclusively when the diesel engine is running. When the cooling function is switched on, the humidity in the operator's cab is reduced at the same time.



The ventilation blows fresh air into the operator's cab.

It is possible to set the temperature in a range of 16 °C to 28 °C.

The air conditioning system functions optimally under the following conditions:

- Diesel engine is running.
- Automatic mode is switched on.
- Windows and doors are closed.
- Air outlets are opened.







The colour of buttons on the display show whether the function is active.

Representation	Meaning
	Function not active
	Function active

Tab. 20: Example representation for all buttons

LFR/1220115/01/2019-10-25/en

3.2.15 Camera image contrast submenu

Menu call:  >  >  or  >  > 

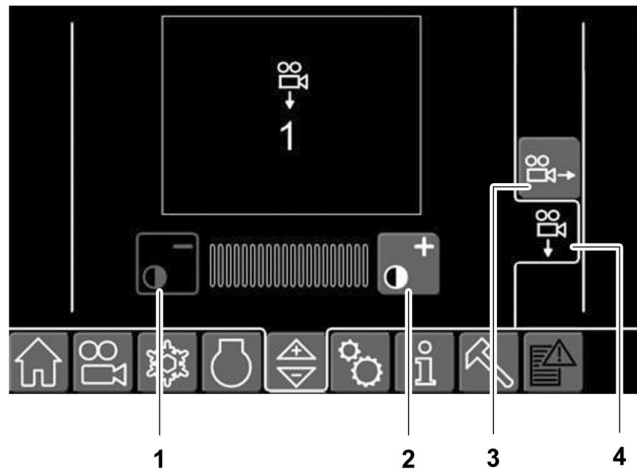

Fig. 174: Camera image contrast submenu

- | | | | |
|---|---|---|------------------------------|
| 1 | Reducing camera image contrast button | 3 | Side area camera menu button |
| 2 | Increasing camera image contrast button | 4 | Rear area camera menu button |

3.2.16 Camera return time submenu

Menu call:  >  > 

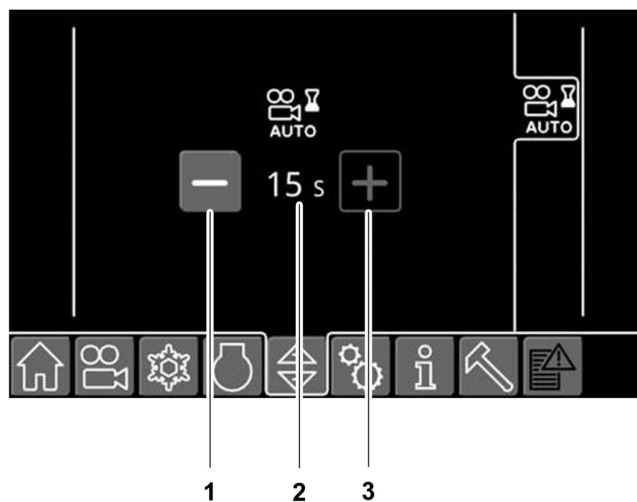

Fig. 175: Camera return time submenu

- | | | | |
|---|-----------------------------|---|-------------------------------|
| 1 | Reducing return time button | 3 | Increasing return time button |
| 2 | Return time | | |

LFR/1220115/01/2019-10-25/en

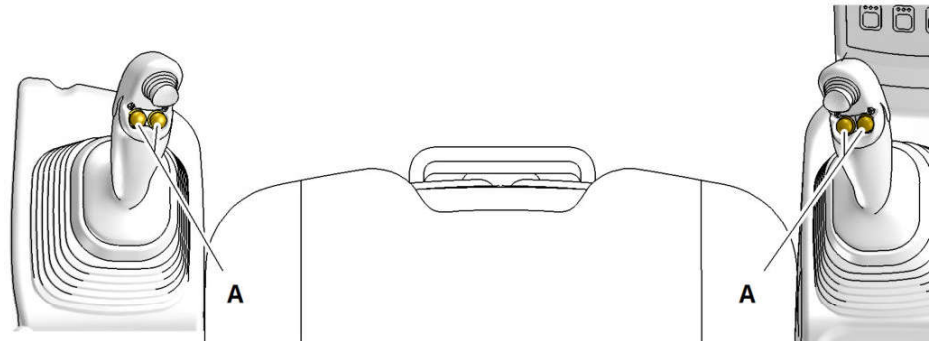

Fig. 210: Possible positions of quick-selection button

A Quick-selection button



Note

Different machine configuration!

▶ Adhere to control description sticker.

- ▶ Assign function to quick-selection button A: Press button (1, 2, 3, 6, 7).
 - ▷ Setting is saved in active user profile. (For more information see: 3.2.29 User profile submenu, page 94)
- ▶ Accept phone call: Press quick-selection button A for less than 1 second.
- ▶ End or reject phone call: Press quick-selection button A for more than 1.5 seconds.

Fine adjustment submenu

Menu call:  >  > 



User profile menu button

Individual user settings of a user profile



AutoLift fine adjustment menu button¹⁰⁾

Fine adjustment of speed of automatic lifting of boom while the grapple is closing.



Grapple fine adjustment menu button

Fine adjustment of speed and force¹¹⁾ for closing grapple and turning grapple



Servo control fine adjustment menu button¹²⁾

Fine adjustment of speed as upper limit for all SuperFinish functions



Slewing gear fine adjustment menu button

Fine adjustment of rotating speed of uppercarriage

¹⁰⁾ Applies to machines with AutoLift

¹¹⁾ Option LH 110 and LH 150

¹²⁾ Applies to machines with adjustable control pressure limitation

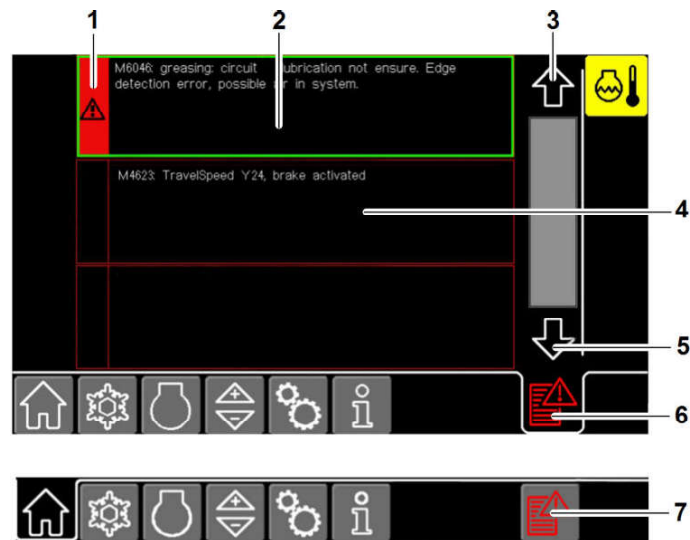

Fig. 241: Service codes menu

- | | | | |
|---|-------------------------|---|----------------------|
| 1 | New service code button | 5 | Scroll-down button |
| 2 | Text field | 6 | Service codes menu |
| 3 | Scroll-up button | 7 | Service codes button |
| 4 | Text message | | |

If exclusively a text message 4 appears in *service codes menu 6*:

- Message is not up to date.
- Message is not confirmed.



If *service codes button 7* flashes red:

- ▶ Open *service codes menu 6*: Press *service codes button 7*.
 - ▷ *New service code button 1* appears in red:



- ▶ Read message in text field 2.
- ▶ Confirm message: Press *new service code button 1*.
 - ▷ *New service code button 1* appears in white:



- ▷ *Service codes button 7* flashes white:



- ▶ Rectify fault.

If it is not possible to rectify fault:

- ▶ Contact Liebherr customer service.

Adjusting horizontal suspension (option)

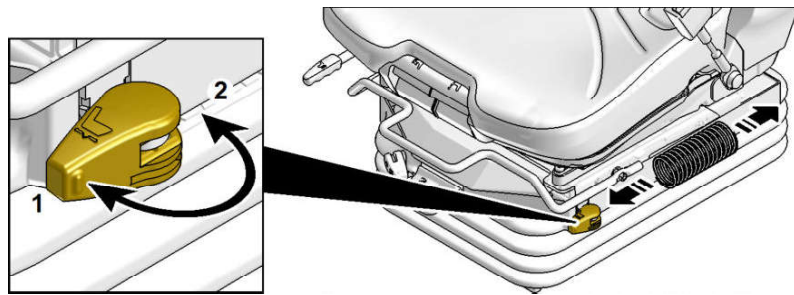

Fig. 264: Adjusting horizontal suspension

1 Horizontal suspension inactive 2 Horizontal suspension active

Adjusting seat height and adapting operator's seat to body weight

Adjusting operator's seat manually

Standard seat

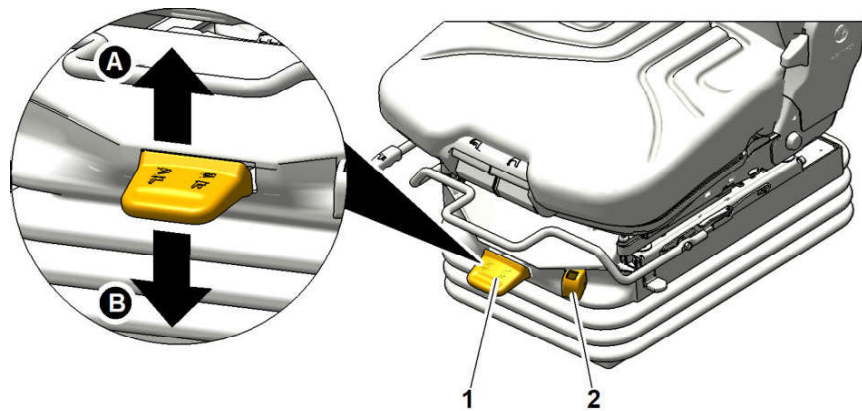

Fig. 265: Standard seat

A Increase 1 Adjustment lever
B Reduce 2 Display

- ▶ Sit on operator's seat.
- ▶ Adjust with adjustment lever 1 until display 2 is green.

Sun blind on the roof glass panel

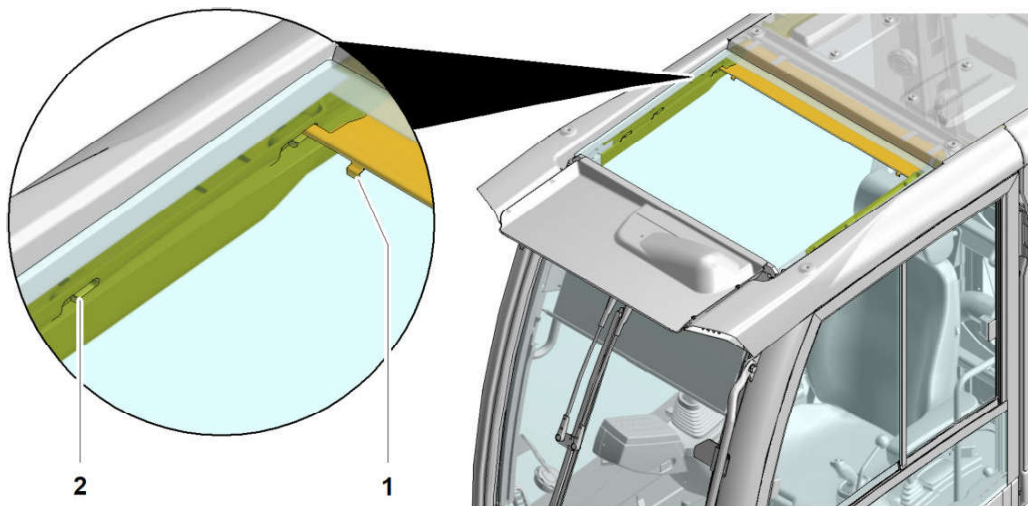

Fig. 290: Sun blind on the roof glass panel

1 Tab

2 Groove

Rolling out sun blind on the roof glass panel

- ▶ Pull sun blind forward on the roof glass panel using tabs 1.
- ▶ Clip sun blind into grooves 2 on the roof glass panel.

Rolling back sun blind on the roof glass panel

- ▶ Lift sun blind out of grooves 2 carefully and let it roll back carefully.

Sun visor in the operator's cab (option)

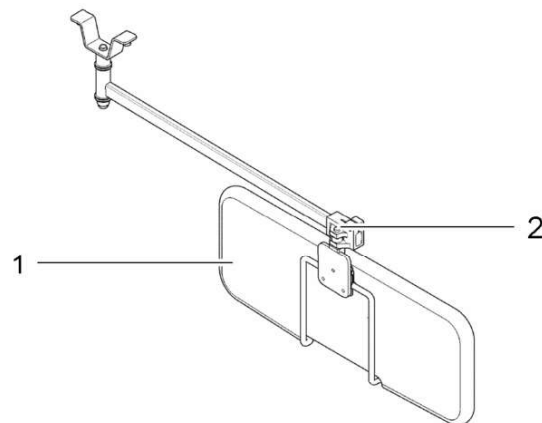
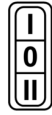

Fig. 291: Sun visor in the operator's cab

1 Sun visor

2 Knurled screw

- ▶ Adjust sun visor 1.
- ▶ Move sun visor 1: Loosen knurled screw 2.



- ▶ Switch on cab lighting system: Set switch for cab lighting system **2** to II.
 - ▷ Cab lighting system switches on automatically when cab door is opened.
 - ▷ Cab lighting system switches off automatically when cab door is closed.
- ▶ Switch off cab lighting system: Set switch for cab lighting system **2** to 0.

Reading lamp



- ▶ Make sure that ignition key is set to 1.
- ▶ Switch on reading lamp: Set switch for reading lamp **3** to I.
- ▶ Switch off reading lamp: Set switch for reading lamp **3** to 0.

3.3.16 Windshield wipers

Key		Status of LEDs	Operating mode
Windshield			Intermittent operation: Press once.
			Continuous operation: Press twice.
Roof glass panel			Intermittent operation: Press once.
			Continuous operation: Press twice.
Rear window			Intermittent operation: Press once.
			Continuous operation: Press twice.

Tab. 33: Operating mode

3.3.17 Windscreen washer system

Windscreen washer system



- ▶ Switch on the windscreen washer system: Press and hold the *windshield* key.
 - ▷ Windshield wiper is in continuous operation.
 - ▷ Windshield washer fluid is sprayed onto the windshield.

Roof glass panel washer system



- ▶ Switch on the roof glass panel washer system: Press and hold the *roof glass panel* key.
 - ▷ Windshield wiper is in continuous operation.
 - ▷ Washer fluid is sprayed onto the roof glass panel.

CLICK HERE TO **DOWNLOAD** THE COMPLETE MANUAL

- Thank you very much for reading the preview of the manual.
- You can download the complete manual from: www.heydownloads.com by clicking the link below



- Please note: If there is no response to CLICKING the link, please download this PDF first and then click on it.

CLICK HERE TO **DOWNLOAD** THE COMPLETE MANUAL

3.4.9 Bringing machine to operating temperature

Make sure the following preconditions are met:

- ❑ Hydraulic oil is approved for ambient temperature range. (For more information see: 5.3.6 Hydraulic oils, page 266)
- ▶ Move folding console up.
- ▶ Start machine and run at idle speed for 15 seconds.
- ▶ Move folding console down.
- ▶ Set engine speed no higher than half the maximum engine speed.
- ▶ Maintain speed and activated working hydraulics.
- ▶ Wait until operating temperature for hydraulic oil and coolant has been reached.
 - ▷ Machine is ready for operation.

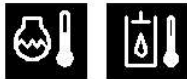

3.4.10 Engine speed and operating mode

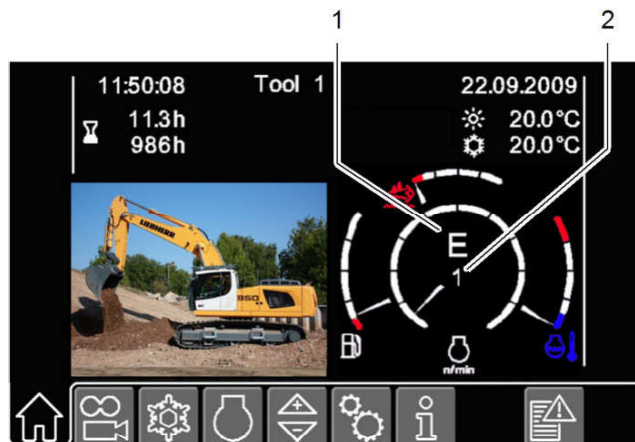

Fig. 347: Speed step and operating mode

1 Operating mode

2 Speed step

Engine speed

Ten speed steps can be selected.

- ▶ Increase speed step: Turn engine speed controller in clockwise direction.
- ▶ Reduce speed step: Turn engine speed controller in counter-clockwise direction.

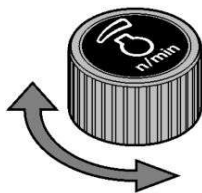

Operating mode

The four operating modes permit optimum use of the machine according to the work to be done.

Controlling dozer blade with right mini-joystick (option)

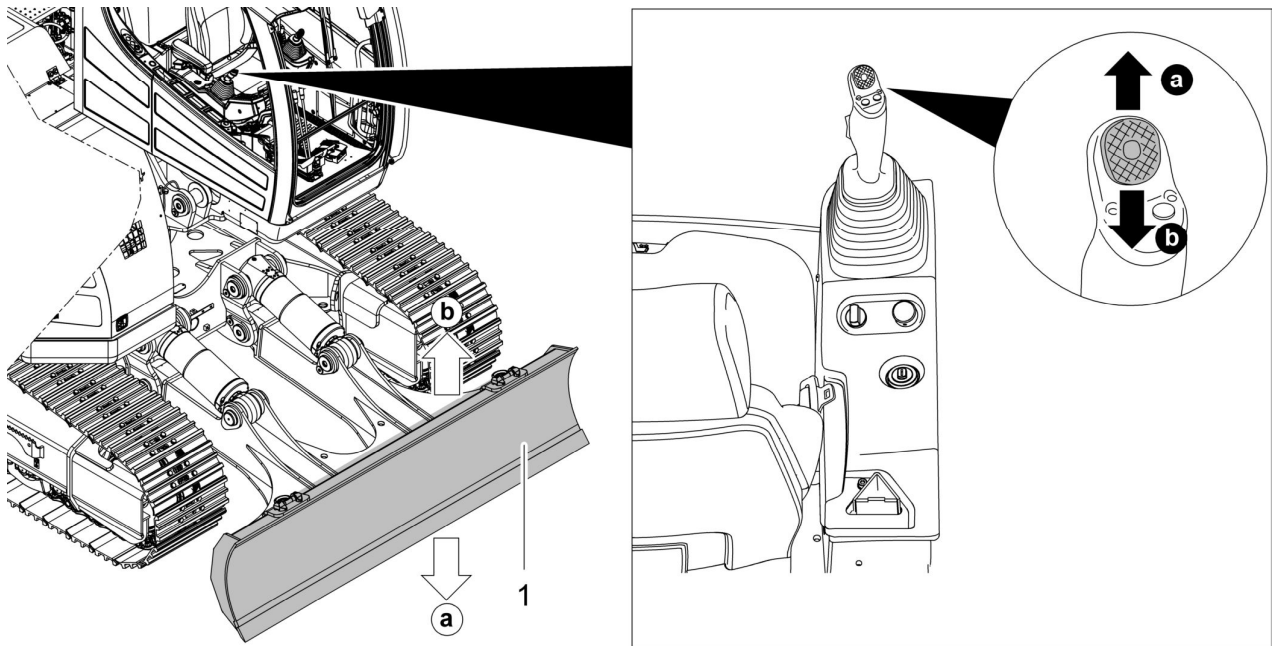

Fig. 376: Controlling dozer blade with right mini-joystick

1 Dozer blade

- ▶ Lower dozer blade 1: Move right mini-joystick in direction a.
- ▶ Raise dozer blade 1: Move right mini-joystick in direction b.



3.4.18 Controlling the working attachment

An information sticker on the side window of the operator's cab explains the operating principle of the controls.

The controls described below meet the **ISO standard for controllers** and are part of the standard equipment of the machine.

In a machine with a control variant:

- It is the operator who decides how the control variant is activated.
- Controls are specific to the options.

Key	Status of LEDs	Meaning
		Automatic mode combined with manual mode: Hoist cylinder protection is active as long as a button is pressed. (For more information see: Manually activating protection, page 162)
		Automatic mode combined with continuous mode: Hoist cylinder protection is permanently active.

Tab. 42: Combined protection modes

Make sure the following preconditions are met:

- Automatic mode is selected. (For more information see: [Selecting automatic protection mode, page 162](#))
- ▶ Combine automatic mode with required manual mode: Press and hold *hoist cylinder protection* key until required mode combination is reached.



3.4.22 Controlling special working attachment without mini-joystick (option)



Selecting special working attachment

If available:

- ▶ Select special working attachment from *Tool Control* menu on the display.

Controlling special working attachment with double pedal

The functions of the double pedals vary by machine configuration.

Key	Function
	Automatic reversible fan drive is switched off.
	Automatic reversible fan drive is switched on.

Tab. 47: Automatic reversible fan drive button

- ▶ Make sure that air intake area is free from persistent soiling (For more information see: [5.9.2 Checking cooling system and heat exchanger for contamination, page 311](#)) (For more information see: [5.9.2 Checking cooling system and heat exchanger for contamination, page 311](#)) .

If new reduced working height is higher than previously set reduced working height:

- ▶ Bypass height limitation. (For more information see: [Bypassing height limitation, page 185](#))
- ▶ Move working attachment to required reduced working height.
- ▶ Press *reduced working height* button.
- ▶ Press confirmation button.
 - ▷ Required reduced working height is saved.



Entering reduced working height

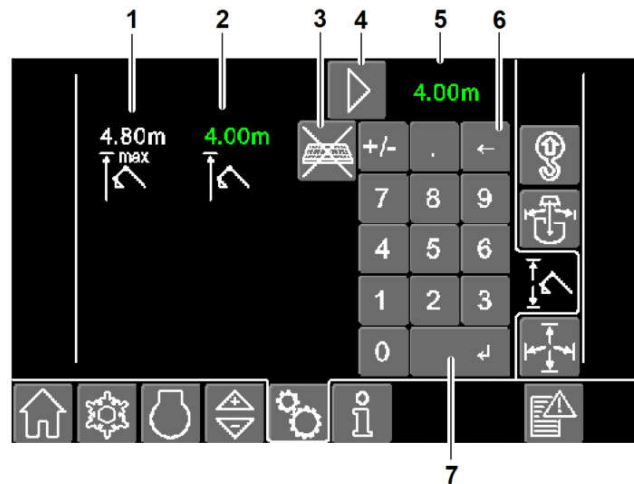

Fig. 470: Entering limit value manually menu

- | | | | |
|---|---------------------------------------|---|--------------------------|
| 1 | Limit value of maximum working height | 5 | Manually set limit value |
| 2 | Limit value of reduced working height | 6 | Delete button |
| 3 | Hiding keyboard button | 7 | Accept button |
| 4 | Changeover button | | |

Make sure the following preconditions are met:

- Height limitation is switched on.
- Machine is in working position.
- Working tool operating mode is selected.



- ▶ Press *showing keyboard* button.
 - ▷ *Entering limit value manually* menu appears on the display.

If limit value of maximum working height **1** appears green:

- ▶ Press *changeover* button **4**.
 - ▷ Limit value of reduced working height **2** appears in green.

If limit value of reduced working height **2** appears in green:

- ▶ Enter limit value of reduced working height **2**.
- ▶ Press *accept* button **7**.
- ▶ Press confirmation button.
 - ▷ Limit value of reduced working height **2** is saved.
- ▶ Press *hiding keyboard* button **3**.
 - ▷ *Height limitation* menu appears on the display.

3.6.4 Travelling under obstacles

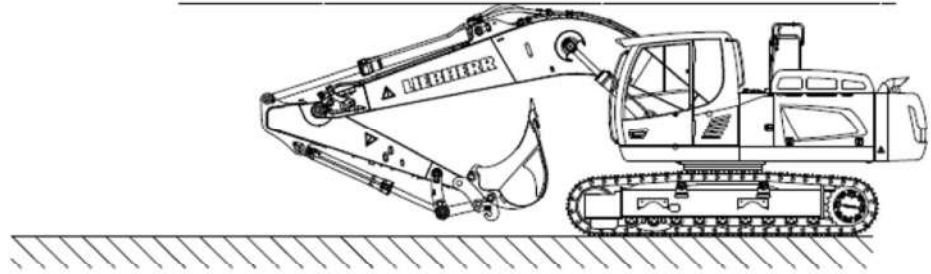

Fig. 487: Travelling under obstacles

During travel under obstacles, travel position of working attachment does not match the position described in "Travelling" chapter and working tool can block the view.

NOTICE

Impact of working tool on the ground! Impact of working attachment on the ground! Damage to working tool and working attachment.

- ▶ If possible travel on level and firm ground.
 - ▶ Travel slowly.
 - ▶ Adapt height of working attachment to ground conditions.
 - ▶ If necessary consult third person as spotter.
-

- ▶ Lower boom.
- ▶ Retract stick.
- ▶ Tilt bucket in.
- ▶ Activate creeper gear.
- ▶ Start travel.

3.6.5 Working on a slope



DANGER

Machine tipping over!
Danger to life.

- ▶ Do not exceed maximum permitted incline.
 - ▶ Make sure that slope has suitable grip and firmness.
-

The maximum permitted incline depends on the machine configuration.

- ▶ Make sure that exclusively the rigger attaches and releases loads.
- ▶ Make sure that rigger leaves the danger zone after attaching and releasing of load.
- ▶ Exclusively raise and lower loads vertically.
- ▶ Move loads close to the ground.

3.6.14 Lifting loads with quick coupler

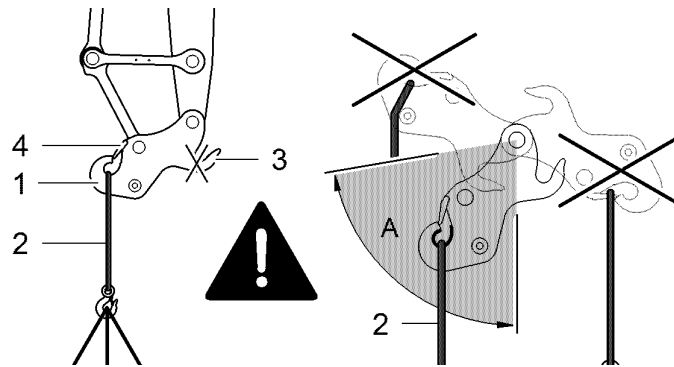

Fig. 497: Lifting loads with quick coupler

- | | | | |
|---|-------------------------------|---|-------------------------|
| 1 | Load hook | 4 | Safety flap |
| 2 | Lifting accessory | A | Permitted slewing range |
| 3 | Pick-up hook for working tool | | |

The quick coupler has two load lift hooks 1 for load-lifting work.

The maximum load capacity value of each load lift hook 1 is specified on the quick coupler.

Preparing load-lifting work

- ▶ Remove working tool from quick coupler and secure it.
- ▶ Fully retract locking pin.
- ▶ Align opening of the load lift hooks 1 upward.
- ▶ Check function of the safety flaps 4.

Lifting loads



DANGER

Machine tipping over or falling loads!
Danger to life.

- ▶ Make sure that no-one is in danger zone.
 - ▶ Have load-lifting work carried out exclusively by trained personnel.
 - ▶ Exclusively move quick coupler within the permitted slewing range A.
-
- ▶ Exclusively attach loads to load lift hooks 1.
 - ▶ Do not put load on safety flaps 4.
 - ▶ Observe maximum load lift of the load lift hooks 1.

3.8 Parking machine

**DANGER**

Machine tipping over!
Danger to life.

- ▶ Make sure that ground has suitable grip and firmness.

**Note**

Battery discharges during longer downtime.

- ▶ Check charging state of battery.

**Note**

- ▶ Exclusively park machine on slope as an exception.

3.8.1 Parking machine on level ground

If ambient temperature is below 0 °C:

- ▶ Avoid freezing onto the ground: Park machine on boards.
- ▶ Turn operator's cab over idler-wheels.
- ▶ Align uppercarriage parallel to undercarriage.
- ▶ Lock slewing brake.
- ▶ Lower working attachment to the ground.
- ▶ Shut off diesel engine.
- ▶ Make sure that ignition key is set to I.
- ▶ Make sure that folding console is folded down.
- ▶ Depressurise hydraulic system: Carefully move joysticks and pedals in all directions.
- ▶ Move folding console up.
- ▶ Pull out ignition key.
- ▶ Lock all doors and flaps and remove key.

If machine will not be used for a long time:





- ▶ Set battery main switch to 0.

3.10 Emergency operation

3.10.1 Using emergency mode

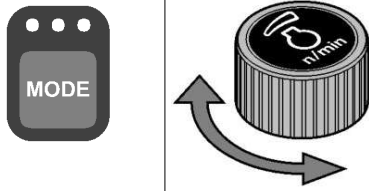
Exclusively use emergency mode to perform following measures:

- Starting diesel engine in the event of an electronic error
- Releasing slewing brake
- Forcing all machine movements

Status symbol	Inactive control element	Status
		Diesel engine at idle speed or rated speed
		Slewing brake released
		Machine movements slowed

Tab. 53: Properties of emergency mode

The main circuit board is behind the operator's seat.

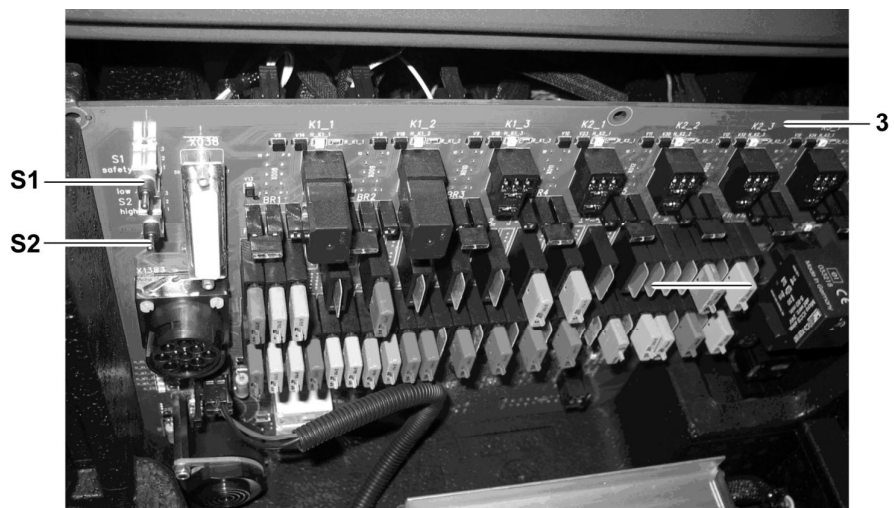











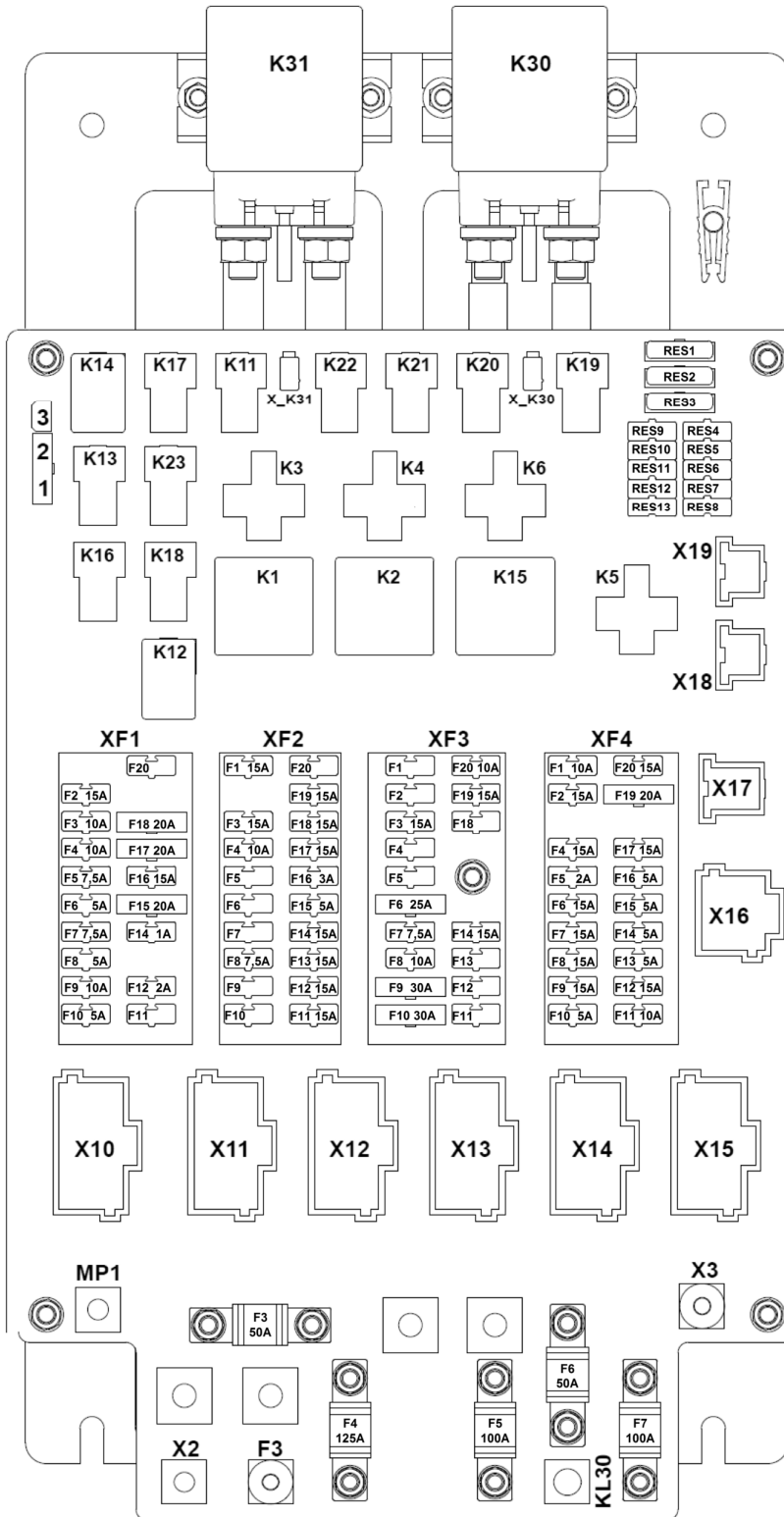

Fig. 520: Main circuit board

- S1 Switch
- S2 Switch
- 3 Main circuit board

LFR/1220115/01/2019-10-25/en

Symbol	Meaning	Effect, characteristic	Remedy
	Control circuit of hydraulic system is depressurised.	Control of working attachment and uppercarriage is not possible.	Shut off diesel engine and restart. If symbol is still displayed: Contact Liebherr customer service.
	A general control error has occurred.	Functionality is restricted. Machine is damaged.	Shut off diesel engine. Contact Liebherr customer service.
	Software parameters missing after software update.	Diesel engine does not start.	Contact Liebherr customer service.
	Machine and attachment parameters do not match.	Diesel engine output is reduced automatically.	Contact Liebherr customer service.
	Prewarning: Diesel particulate filter is heavily contaminated.		Start manual filter regeneration.
	Diesel particulate filter is excessively contaminated.	Diesel engine output is reduced automatically.	Contact Liebherr customer service.
	Prewarning: DPF: Diesel exhaust fluid level is low.		Fill with diesel exhaust fluid.
	DPF: Diesel exhaust fluid level is too low.	Diesel engine output is reduced automatically.	Fill with diesel exhaust fluid.
	SCR: Diesel exhaust fluid level is too low.	Diesel engine output is reduced automatically.	Fill with diesel exhaust fluid.
	Malfunction of oscillating axle.	Machine stability is at risk.	Shut off diesel engine. Contact Liebherr customer service.
	Oil temperature of pump distributor gear is too high.	Pump distributor gear is damaged.	Shut off diesel engine. Reduce load. Clean hydraulic oil cooler. If symbol is still displayed: Contact Liebherr customer service.



LFR/1220115/01/2019-10-25/en

Fig. 605: Electric cabinet A214

5 Maintenance

5.1 Inspection and maintenance schedule

General information

Abbreviations used in this section: h = operating hours

Shorten maintenance intervals according to operating conditions, for example:

- Dust intensive application
- Oil quality
- Fuel quality

Make sure lubricants, fluids and replaced parts are disposed of safely and in eco-friendly manner. Adhere to country-specific directives applicable in country of use and to relevant applicable laws.

The service packages in the spare parts catalogue contain the spare parts required for maintenance tasks.

Symbols	Affected employees
Filled-in symbols	Machine owner or their maintenance staff that perform maintenance tasks independently
Empty symbols	Trained staff authorised by Liebherr

Tab. 64: Meaning of symbols

5.3.3 Engine oils

Liebherr recommendation for stage IV / Tier 4f and stage V diesel engines

Description
Liebherr Motoroil 5W-30 low ash

Tab. 71: Liebherr recommendation

Other approved engine oils

Description
Liebherr Motoroil 10W-40 low ash

Tab. 72: Other approved engine oils

Minimum quality requirements

Specification
LH-00-ENG3A LA
ACEA E6, ACEA E9, API CJ-4
DQC III LA, DQC IV LA

Tab. 73: Minimum quality requirements

Liebherr recommendation for other emission stages

Diesel engine power	Performance category
Up to 129 KW	Power band I as per Regulation ECE-R.96 (stage 3A, TIER III, CHINA III equivalent)
From 130 KW	Power band H as per Regulation ECE-R.96 (stage 3A, TIER III, CHINA III equivalent)

Tab. 74: Liebherr recommendation for other emission stages

Description
Liebherr Motoroil 10W-40

Tab. 75: Liebherr recommendation

Other approved engine oils

Description
Liebherr Motoroil 5W-30

Tab. 76: Other approved engine oils

5.5 Preparing for maintenance

5.5.1 Maintenance procedures

Definition of maintenance tasks



Note

Put machine in maintenance position before beginning maintenance tasks. ([For more information see: 5.5.3 Putting machine in maintenance position, page 275](#))

Following maintenance tasks are defined:

- Lubricate complete machine.
- Check complete machine for cracks.
- Change fuels and operating fluids.
- Replace filter.
- Clean components.
- Check hydraulic system.
- Perform visual inspection for defects.

Definition of visual inspection

Symbol	Meaning
	Visual inspection Indicates places to be examined by visual inspection.

Tab. 96: Symbol of visual inspection

Visual inspection is a visual inspection process of the complete machine and individual components.

The legal basis for visual inspection is provided by DIN EN 13018 or country-specific standards, ordinances and regulations.

Visual inspection without aids

Criteria for the visual inspection without aids are:

- An uninterrupted optical path between the eyes of the inspector and the inspected surface.
- Examination of the complete machine and individual components with the naked eye.

Visual inspection with aids

Criteria for the visual inspection with aids are:

- An interrupted optical path between the eyes of the inspector and the inspected surface.
- Examination of the complete machine and individual components with suitable aids such as mirrors, magnifiers and lighting.

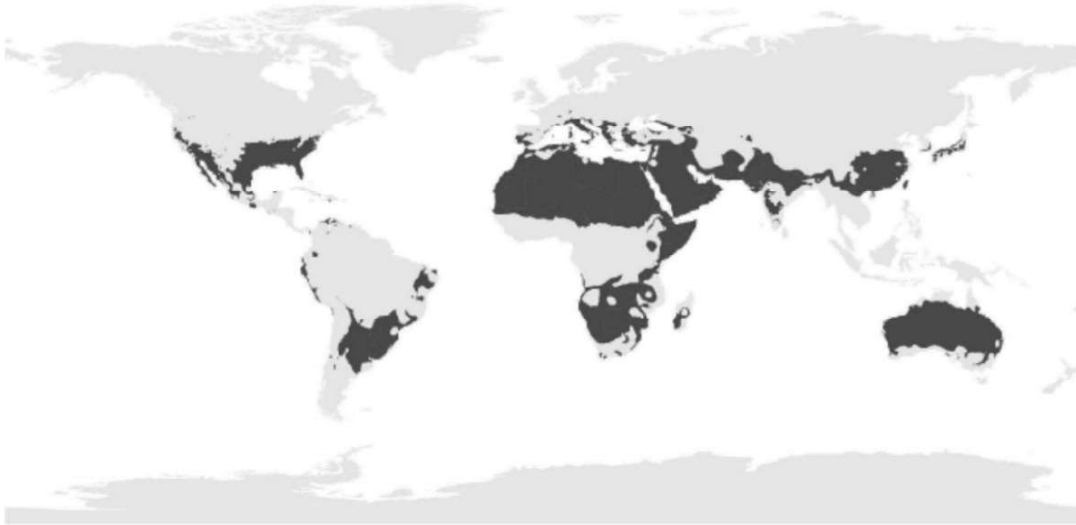

Fig. 629: Subtropical climate



Fig. 630: Tropical climate

Reference documents



Note

- ▶ Adhere to technical data sheets and safety data sheets of products.

Requirements and description

Conserving corrosion protection

The corrosion protection of the entire machine must be checked. In case of defects in the protection it must be renewed. The inspection interval must be specified according to following table.

Unprotected areas must be cleaned before treatment with protection products.

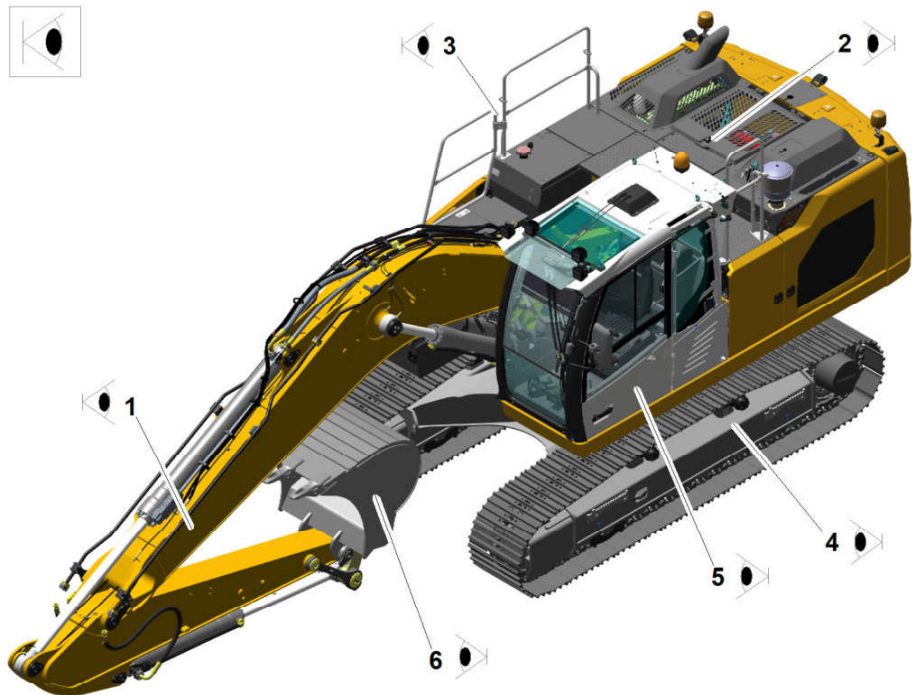

Fig. 632: Checking components for cracks

Position	Assembly	Visual inspection for defects
1	Steel frame of working attachment	Check bearing points, supports, holders, fastening elements, connections for damage, warping and cracks.
2	Steel frame of uppercarriage	
3	Steel frame of climbing aids and hand rails	
4	Steel frame of undercarriage	
5	Steel frame of operator's cab	
6	Steel frame of quick coupler and working tool	

Tab. 110: Visual inspection for defects

Visual inspection during maintenance work or inspection tour

- ▶ Perform visual inspection. (For more information see: [Definition of visual inspection, page 273](#))

If defects occur in machine:

- ▶ Record any identified defects.
- ▶ Inform operating company of defects affecting safety.
- ▶ Repair identified defects. See service manual for procedure.

LFR/1220115/10/1/2019-10-25/en

Correcting concentration of anti-freeze and corrosion protection agent

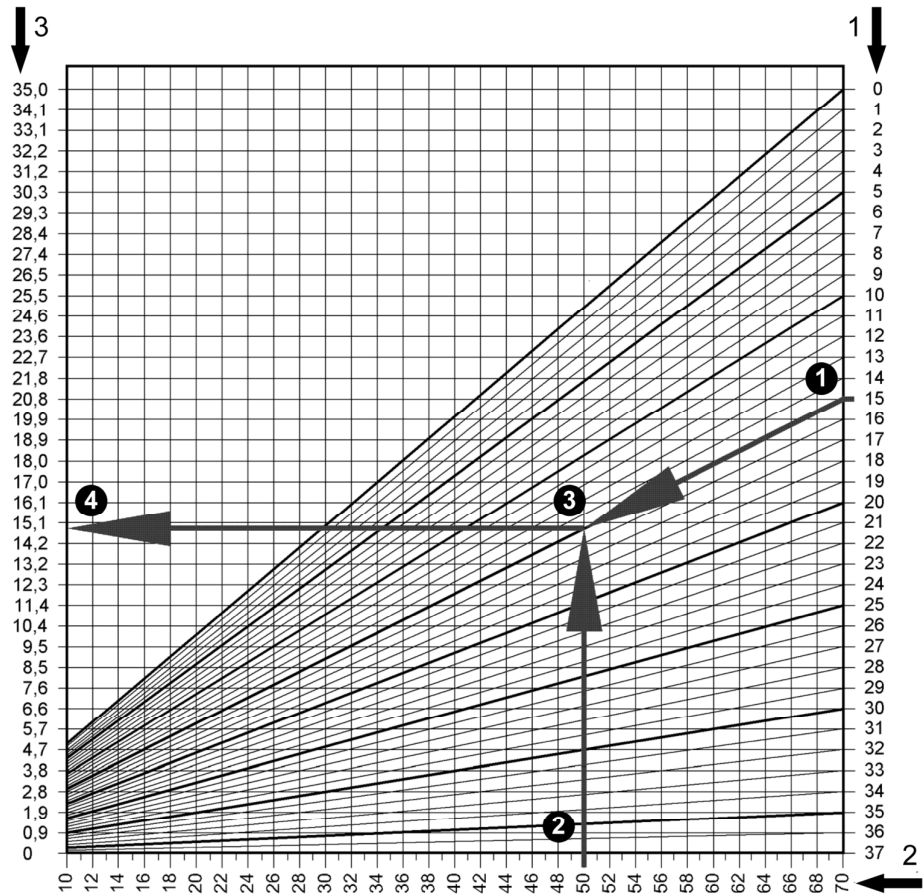

Fig. 648: Diagram

- | | |
|--|--|
| <p>1 Temperature of anti-freeze and corrosion protection agent (°C negative)</p> <p>2 Coolant quantity in cooling system (l)</p> | <p>3 Anti-freeze and corrosion protection agent quantity to be added (l)</p> |
|--|--|

NOTICE

Incorrect correction of anti-freeze and corrosion protection agent concentration!
Damage to diesel engine and cooling system.

- ▶ Use approved anti-freeze and corrosion protection agent.
- ▶ Do not top up more than 60 % of anti-freeze and corrosion protection agent.

Example on use of diagram (see: fig. 648, page 313) :

- Temperature of anti-freeze and corrosion protection agent: -15 °C
- Coolant quantity in cooling system: 50 l
- ▶ Starting at the anti-freeze and corrosion protection agent temperature of -15 °C, follow line downwards to vertical line that corresponds to a coolant quantity of 50 l.

5.12 Travel gear

5.12.1 Checking track tension

Normal wear on the travel gear causes the track tension to slacken over time. The track tension must be checked regularly and increased if necessary.

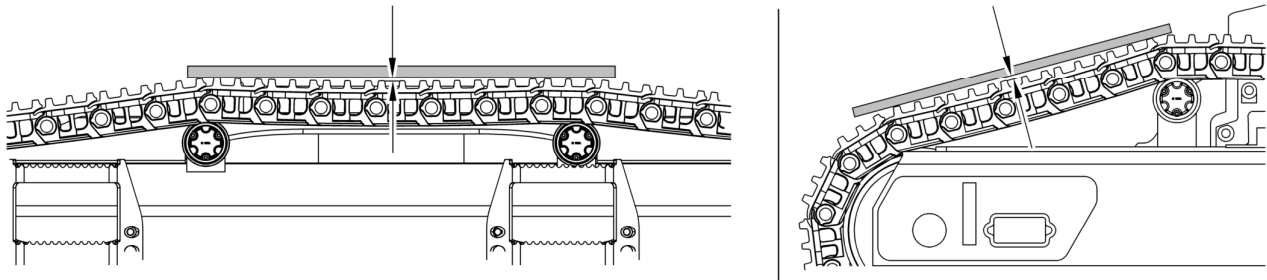

Fig. 656: Checking track tension

Make sure the following preconditions are met:

- ❑ Machine is secured to prevent it rolling.
- ▶ Move machine forwards and backwards to release tension in tracks.
- ▶ Measure centre-to-centre distance between two carrier rollers.
- ▶ Measure centre-to-centre distance between idler-wheel and the first carrier roller.
- ▶ Place measuring bar on the section of the track with the biggest centre-to-centre distance.
- ▶ Measure distance between bottom of measuring bar and top of track pad.
 - ▷ In normal conditions the track should sag by 25 ± 5 mm .
- ▶ If necessary: Tighten track. ([For more information see: 5.12.2 Tightening track, page 324](#))
- ▶ Repeat procedure for the second track.

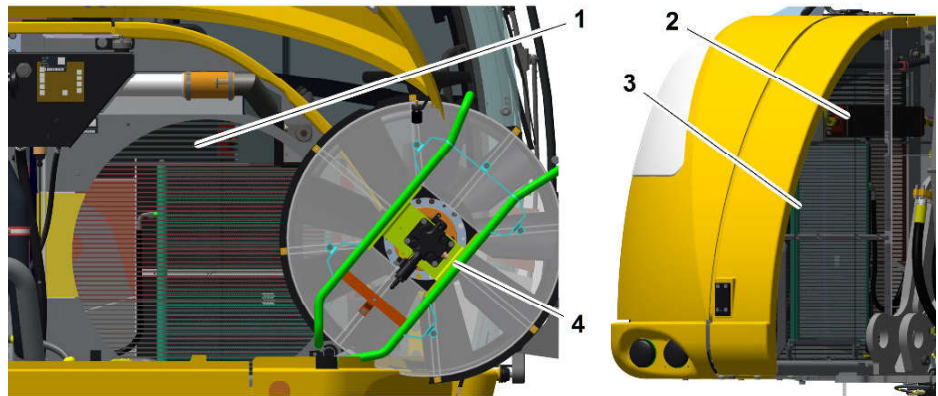

Fig. 664: Radiator and air conditioning condenser

- | | | | |
|---|--------------------------|---|----------------------------|
| 1 | Combination cooling unit | 3 | Air conditioning condenser |
| 2 | Fuel cooler | 4 | Radiator fan |

- ▶ Loosen nut on radiator fan 4.
- ▶ Move radiator fan 4 to the side.
- ▶ Check air conditioning condenser 3 for contamination and clean if necessary.
- ▶ Clean contaminated condenser fins with compressed air.
- ▶ Move radiator fan 4 back.
- ▶ Tighten nut on radiator fan 4.

5.14.5 Dust-intensive condenser unit (option)

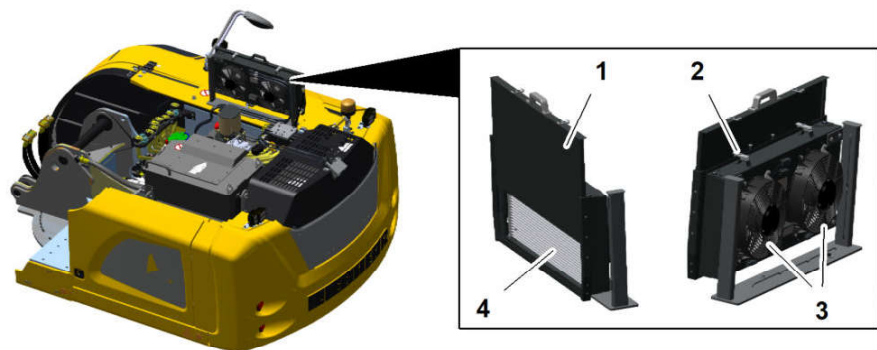

Fig. 665: Dust-intensive condenser unit

- | | | | |
|---|-----------------|---|--------------|
| 1 | Condenser cover | 3 | Radiator fan |
| 2 | Clip | 4 | Condenser |

- ▶ Open clip 2 on condenser cover 1.
- ▶ Remove condenser cover 1.
- ▶ Check condenser 4 for contamination and clean if necessary.
- ▶ Clean contaminated condenser fins with compressed air.
- ▶ Install condenser cover 1.
- ▶ Close clip 2 on condenser cover 1.

CLICK HERE TO **DOWNLOAD** THE COMPLETE MANUAL

- Thank you very much for reading the preview of the manual.
- You can download the complete manual from: www.heydownloads.com by clicking the link below



- Please note: If there is no response to CLICKING the link, please download this PDF first and then click on it.

CLICK HERE TO **DOWNLOAD** THE COMPLETE MANUAL