

en

Operator's manual

Crawler dozer

Document ID

	ORIGINAL OPERATOR'S MANUAL
Order number:	93517144
Issued:	01.11.2017
Version:	05
Author:	LWT / Technical Documentation Department

Product ID

Manufacturer:	Liebherr-Werk Telfs GmbH
Type:	PR 726
Type no.:	1329, 1330, 1331
From Serial no.:	14935

Conformity:



Contact

Liebherr-Werk Telfs GmbH
Hans Liebherr-Straße 35
A – 6410 Telfs

CLICK HERE TO **DOWNLOAD** THE COMPLETE MANUAL

- Thank you very much for reading the preview of the manual.
- You can download the complete manual from: www.heydownloads.com by clicking the link below



- Please note: If there is no response to CLICKING the link, please download this PDF first and then click on it.

CLICK HERE TO **DOWNLOAD** THE COMPLETE MANUAL

3.2.14	Electrical windscreen washer system and window washer system	143
3.2.15	Compartment for documentation	146
3.2.16	Turning on the engine compartment lighting	146
3.2.17	Back up warning device (option)	147
3.2.18	Disengageable back up warning device (option)	148
3.2.19	Fire extinguisher (Option)	149
3.2.20	Rotating beacon	150
3.2.21	LiDAT	150
3.3	Operation	151
3.3.1	Operating machine on a daily basis	151
3.3.2	Using the machine at low or high ambient temperatures	160
3.3.3	Start the diesel engine	161
3.3.4	Travel mode	166
3.3.5	Driving	172
3.3.6	Braking	174
3.3.7	Taking the machine out of service	177
3.3.8	Working in water	181
3.3.9	Working with the attachment	182
3.3.10	Working with optional attachments	190
3.3.11	Diesel particle filter (option)	198
3.4	Work methods	204
3.4.1	Grading	204
3.4.2	Fine grading	205
3.4.3	Using several machines simultaneously	206
3.4.4	Creating and banking up trenches	207
3.4.5	Land clearing	208
3.4.6	Ripping	210
3.5	Install and remove the attachment	212
3.5.1	Installation guidelines for installation and removal of attachment parts	212
3.5.2	Install the bearing shells of the attachment	212
3.5.3	Install and remove the push frame with the straight blade	214
3.6	Transport	222
3.6.1	Transporting the machine by truck or rail	222
3.6.2	Loading the machine with the crane	225
3.7	Emergency operations	228

Efficiency

Cost efficiency comes standard

Reliability

Robust design in every regard

Comfort

Ample space, ergonomics and comfort – All in one

Maintainability

Simple maintenance and an extensive service network



Cost-effective maintenance

Simple daily checks

All items that the operator checks during daily routine inspections are readily accessible on one side of the engine. The hydraulically tilted cab provides easy access to components as well. Service work can be performed quickly and efficiently.

Long maintenance intervals

Perfectly matched components and lubricants allow for exceptionally long maintenance intervals, e.g. up to 2,000 operating hours for the diesel engine. Hydraulic oil change intervals of up to 8,000 operating hours save costs and minimise downtime.

Optimal planning

Planned costs

Liebherr crawler dozers come with extensive standard warranties for the entire machine and the drive train. Customised inspection and service programs allow optimal planning of all maintenance activities.

Remanufacturing

The Liebherr remanufacturing program offers cost-effective reconditioning of components to the highest quality standards. Various reconditioning levels are available: Replacement components, general overhaul or repair. The customer receives components with original part quality at a reduced cost.

The focus is on the customer

Professional advice and service

Professional advice is given at Liebherr. Experienced specialists provide decision-guidance for your specific requirements: application-oriented sales support, service agreements, value-priced repair alternatives, original parts management, as well as LiDAT remote data transmission for machine planning and fleet management.

Continuous dialogue with users

We utilise the expert knowledge and practical experience of our customers to consistently optimise our machines and services – real solutions for real situations.



Easy access

- All service points are centrally located and easily accessible. Thanks to wide-opening access doors, routine inspection of the machine is easily performed.
- The lube point for the oscillating bar bearing is located very conveniently in the engine compartment.
- Optional lighting in the engine area makes maintenance and service work easy.

Tilt-out cooling fan

- In especially dusty applications, the swingout fan of the PR 726 simplifies the cleaning of the cooling system.
- The radiator grille requires no tools to open.

Expedited spare parts service

- 24-hour delivery: spare parts service is available for our dealers around the clock.
- Electronic spare parts catalogue: fast and reliable selection and ordering via the Liebherr online portal.
- With online tracking, the current processing status of your order can be viewed at any time.

1.3 Tightening torques

1.3.1 Preload values and tightening torques for screws with standard and fine metric thread according to DIN ISO 261

Screw connections should be mounted so that there is sufficient clamping force under operating loads to ensure that no shearing forces (FQ) act transversely to the screw axis. If the transverse forces are greater than the clamping force, this will lead to loosening and eventual failure of the connection. The respective required clamping effect is achieved during assembly by tightening the threaded parts.

Standards	Description
DIN ISO 261 (11/1999)	ISO general purpose metric screw threads - General plan (ISO 261:1998)
DIN ISO 262 (11/1999)	ISO general purpose metric screw threads - Selected sizes for screws, bolts and nuts (ISO 262:1998)
DIN ISO 965-2 (11/1999)	ISO general purpose metric screw threads - Tolerances - Part 2: Limits of sizes for general purpose external and internal screw threads - Medium quality (ISO 952-2:1998)
DIN EN ISO 4014 (06/2011)	Hexagon head screws with shank - Product grades A and B (ISO 4014:2011); German version EN ISO 4014:2011
DIN EN ISO 4016 (06/2011)	Hexagon head screws with shank - Product grade C (ISO 4016:2011); German version EN ISO 4016:2011
DIN EN ISO 4017 (05/2015)	Fasteners - Hexagon head screws with thread up to head - Product grades A and B (ISO 4017:2014) German version EN ISO 4017:2014
DIN EN ISO 4018 (07/2011)	Hexagon head screws with thread up to head - Product grade C (ISO 4018:2011); German version EN ISO 4018:2011
DIN EN ISO 4762 (06/2004)	Hexagon socket head cap screws (ISO 4762:2004) German version EN ISO 4762:2004
DIN EN 20273 (02/1992)	Fasteners; clearance holes for bolts and screws (ISO 273:1979); German version EN 20273:1991
DIN 34800 (11/2016)	Bolts and screws with external hexalobular driving feature with small flange
VDI 2230 Sheet1 (02/2003)	Systematic calculation of high stressed bolted joints - Joints with one cylindrical bolt
LH 10215295-002 (06/2015)	LN 252-8 Corrosion protection for low-value standard parts (C parts) salt spray mist test > 480 hours
LH 10021432-010 (06/2015)	Delivery specifications for steel fasteners with zinc coating (FIZn)

Tab. 2: Further applicable documentation

The Id. Numbers are noted in the spare parts list.

2.3.1 Safety signs

Non-observance of safety signs can result in severe injury or death.

Regularly check the safety signs to ensure they are complete and legible.

Replace missing or illegible safety signs immediately.

Location of safety signs

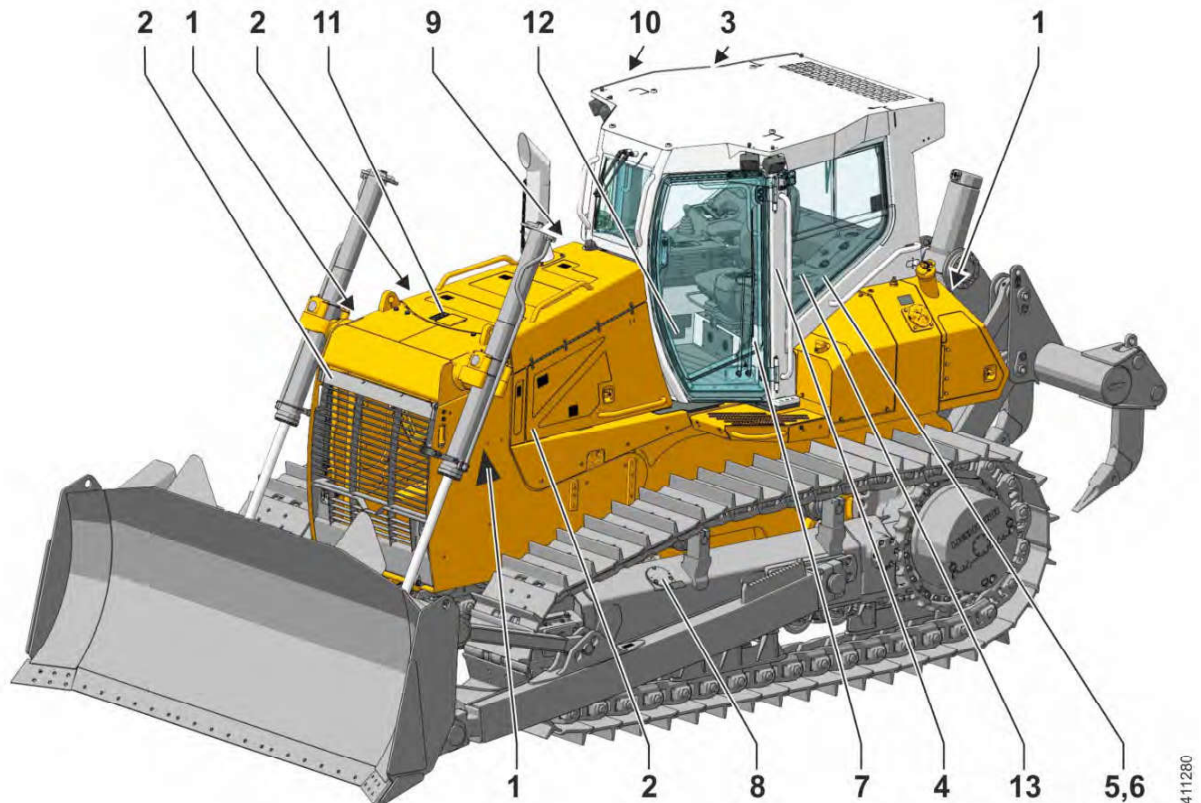

Fig. 11: Location of safety signs

- | | | | | | |
|---|-------------------------|----|----------------------------------|----|------------------------|
| 1 | Stay clear warning sign | 6 | Safety belt sign | 11 | Coolant sign |
| 2 | Engine standstill sign | 7 | Accident prevention sign | 12 | ROPS/FOPS warning sign |
| 3 | Battery sign | 8 | Track tension sign | 13 | Downhill travel sign |
| 4 | Parking switch sign | 9 | Cab tilt unit sign | | |
| 5 | LiDAT sign | 10 | Operator's platform support sign | | |

Travel hydraulics sign



Fig. 28: Travel hydraulics sign

The sign is located on the left of the operator's cab.

Shows operation of the drive lever for the drive functions of the machine.

Working hydraulics sign



Fig. 29: Working hydraulics sign

The sign is located on the right of the operator's cab.

Shows the operation of the attachment of the machine.

Sign 6-way sign (option)



Fig. 30: Sign 6-way sign

9. After entering the cab, adjust the operator's seat, the mirrors, the arm rests and the safety belt so that you can work comfortably.
10. The noise protection devices on the machine must be in protective position during operation.
11. Never operate the machine without the operator's cab or canopy.

2.4.5 Safety guidelines for start up

1. Before starting the machine, check all indicator lights and instrument for proper function. Bring all control levers into neutral position.
2. Before starting the engine, alert any nearby personnel that the machine is being started by sounding the horn.
3. Start the machine only from the operator's seat.
4. If no other instructions were issued, start the engine as outlined in the **Operating instructions**.
5. Start the engine and check all indicators, gauges, instruments and controls.
6. When operating in enclosed spaces, run the engine only if there is sufficient ventilation. If necessary, open doors and windows to ensure sufficient fresh air supply.
7. Bring the engine and the hydraulic oil to operating temperature, low oil temperatures cause the controls to be sluggish.
8. Check that the control for the attachment functions properly.
9. Move the machine carefully into an open area and check all travel functions, check travel brake, the steering function as well as the turn signals and lights.

2.4.6 Safety guidelines for working

1. Before starting to work, familiarize yourself with the peculiarities of the job site, as well as the special regulations and warning signals. Part of the surrounding area includes, for example, the obstacles in the working or traffic area, the load bearing capacity of the ground and special protection required to secure the job site from public highway traffic.
2. Always keep a safe distance to overhangs, edges, embankments and unstable ground.
3. Be particularly cautious of changing ground conditions, unfavorable visibility and changing weather.
4. Familiarize yourself with the location of power lines on the jobsite and work particularly careful in their vicinity. If necessary, inform the responsible authorities.
5. Maintain a safe distance from electrical overhead lines. When working near electrical overhead lines, do not allow the attachment too come close to the wires.
There is a **Danger to life!**
Inform yourself about required safety distances.
6. **If you do touch a high voltage power line, proceed as follows:**
 - Do not leave the machine!
 - If possible, move the machine a sufficient distance away from the danger zone.
 - Warn all personnel in the surrounding area not to come close to the machine and not to touch the machine.
 - Instruct someone to turn the electric power off.
 - Do not leave the machine until you are assured that the electric wire, which has been touched or damaged is no longer energized and the power has been turned off!
7. Before moving the machine or working with the machine, always make sure that the equipment is safely secured.

Not all areas of machine are located in the direct field of view.

The hatched areas in the figure indicate the area that cannot be seen from the operator's workstation.

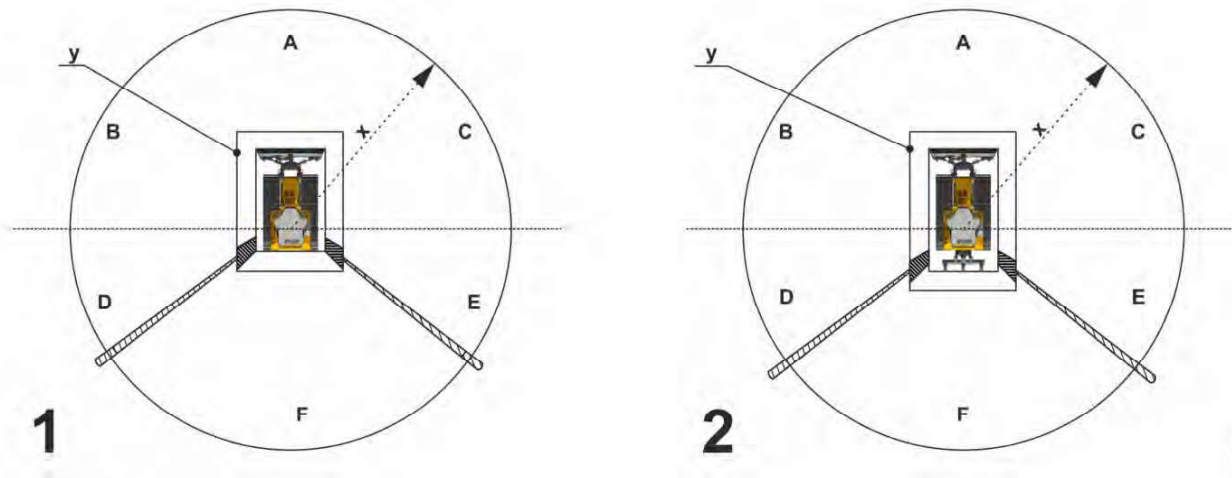

Fig. 46: Field of vision

- | | | | |
|---|--------------------------------|---|-----------------|
| 1 | Machine without rear equipment | x | Radius: 12 m |
| 2 | Machine with rear equipment | y | Near field: 1 m |

The following obscured areas cannot be seen from the operator's workstation:

Obscured view in area D and E due to C-pillars.



WARNING

Restricted field of vision!
Severe injuries, death.

- ▶ Adjust the mirror.
- ▶ When working attachments are used that limit the field of view, measures must be taken to ensure that the machine is operated safely.
- ▶ Remove any obstacles in the work area.
- ▶ Make sure that no persons are within the danger zone.

The machine operator and construction site management must take measures to ensure that the obscured field of vision does not cause a safety hazard during operation.

Measures before and during operation

1. Make sure that persons establish contact with the machine operator before they approach the machine.
2. Check visibility aids for function, cleanliness and correct adjustment.
3. Adjust visibility aids in such a way that the best possible all around visibility is ensured.
4. Clean visibility aids and windows in the operator's cab immediately if dirt affects the visibility.
5. Have defective visibility aids repaired or replaced immediately.
6. Do not use sun visors if they limit visibility.

412990

LWT093517144/05/01.11.2017/en

9 Door windscreen wipers switch



Turn on and off



Windscreen washer system

10 Rear window windscreen wiper switch



Turn on and off



Windscreen washer system

11 Operator's cab front headlight switch



Turn on and off

The headlights on the front of the operator's cab turn on or off after actuating the switch.

12 Operator's cab rear headlight switch



Turn on and off

The headlights on the rear of the operator's cab turn on or off after actuating the switch.

13 Hoist cylinder headlight switch



Turn on and off

Press the switch to turn the headlights at the front on hoist cylinders on or off.

14 Button Reversible fan control (option)



Turn on

After actuating the button, the reversible fan control is started manually.

3.1.3 Display unit

The display unit is the central information source for the operation of machine. It provides information about operating data and functions in the form of text and symbols. The machine is set, monitored and operated on the touch-sensitive Touchscreen display with graphic user interface.

2 Hydraulic oil level (option)



408338

- Display if the hydraulic oil level is too low.
If the display lights up, turn the diesel engine off and remedy the problem.
Check the hydraulic system for leaks.

3 Replenishing pressure¹¹⁾



408339

- Goes out once the diesel engine has started up.
- Display if the replenishing pressure is too low.
If the display lights up, turn the diesel engine off immediately and remedy the problem.

4 Travel gearbox - temperature monitoring¹¹⁾

Travel gearbox, left



408341

- Display if temperature is too high in the left travel gearbox.

Travel gearbox, right



408340

- Display if temperature is too high in the right travel gearbox.

Travel gearbox left and right



408342

- Display if temperature is too high in the left and right travel gearbox.

5 Diesel engine stop



408550

- Display in the case of problems with the diesel engine or the machine.
If the display lights up, turn the diesel engine off immediately and remedy the problem.

6 Diesel engine problem



408874

- Display in the case of a malfunction with the diesel engine.
If the display lights up, turn the diesel engine off immediately and remedy the problem.

¹¹⁾ Except for PR716/PR726 and LR626/LR636

Setting language

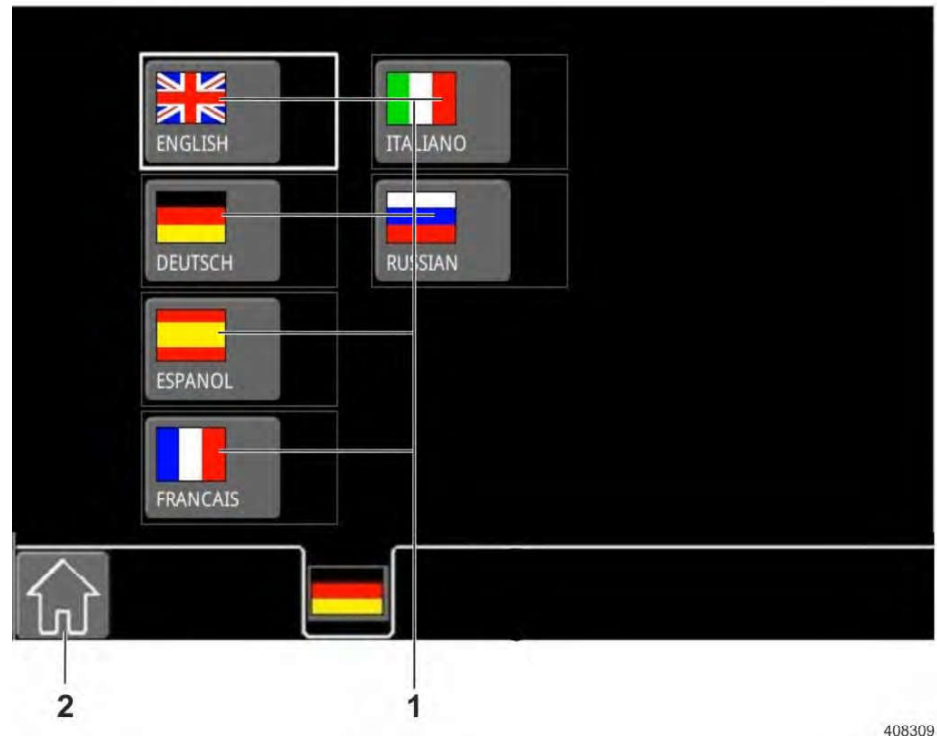
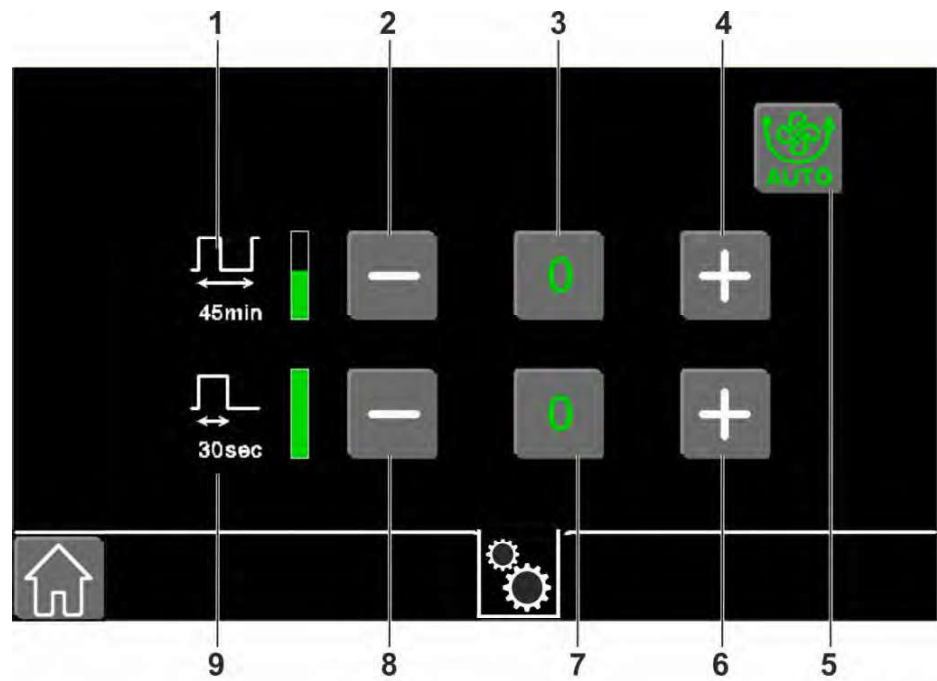

Fig. 153: Set the display language

- 1 Language selection 2 Main menu symbol
- Select the desired language via symbol 1.
 - Leave the menu via the main menu 2 symbol.

Setting reversible fan (option)



410530

Fig. 163: Setting reversible fan

- | | | | |
|---|---|---|-------------------------|
| 1 | Reverse interval | 6 | Reverse duration long |
| 2 | Reverse interval short | 7 | Reverse duration medium |
| 3 | Reverse interval medium | 8 | Reverse duration short |
| 4 | Reverse interval long | 9 | Reverse duration |
| 5 | Turn automatic reverse operating on and off | | |

The reverse interval can be shorted by 10 minutes or extended by 15 minutes.

The reverse duration can be shorted by 10 seconds or extended by 15 seconds.







– Set reverse interval and reverse duration.

By turning the reversible fan off via symbol **5**, the reversible fan and the button in the cab are deactivated.

Warning and malfunction strategies

The exhaust aftertreatment system is monitored by a diagnostics system. If the diagnostics system recognizes an error, for example the fill level or the urea tank is not OK, the urea quality is bad, malfunction of components of the exhaust aftertreatment system or a manipulation on the exhaust aftertreatment system, then a warning or malfunction strategy is activated.

The various statuses of the exhaust aftertreatment system are displayed to the operator by illumination of the respective symbols in the display unit.

Symbol	System status	Limitation
 Exhaust after-treatment off fault	Level 1:	No limitation
 Urea tank content yellow	Urea tank content < 10% or aftertreatment system fault 0 min – 60 min	
 Signal sound		
 Exhaust after-treatment yellow fault	Level 2:	Torque limitation to 80%, move machine out of danger zone
 Urea tank content yellow	Urea tank content < 5% or malfunction exhaust aftertreatment system 60 min – 180 min	
 Signal sound		

LWT093517144/05/01.11.2017/en

Adjusting the operator's seat horizontally



408365

Fig. 189: Adjusting the operator's seat horizontally

8 Operator's seat horizontal adjustment lever

- ▶ Pull the lever 8 up.
- ▶ Adjust the operator's seat horizontally.
- ▶ Release the lever 8.

Adjusting the shock absorber



408370

Fig. 190: Adjusting the shock absorber

11 Shock absorption lever

- ▶ Turn the lever 11 to the desired setting.
 - ▷ soft 1
 - ▷ medium 2
 - ▷ hard 3

Storage net

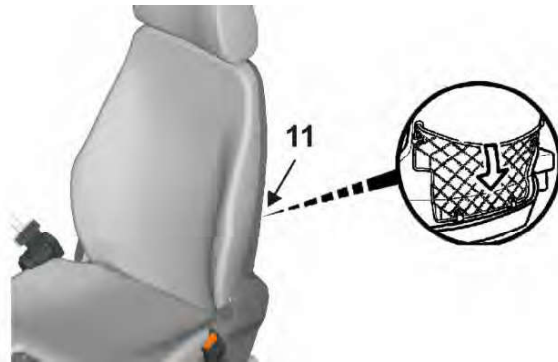

408386

Fig. 207: Storage net

11 Storage net

The storage net is installed at the top on the rear of the backrest.

- ▶ To open the storage net, pull the upper band back.

3.2.7 Premium ISRI (option) operator's seat

The ergonomically designed operator's seat provides a high level of seat comfort.

The adjustability of the seat surface, backrest, suspension and armrests allows the operator to individually adjust the seat to ensure a comfortable seat position.

Vibration damping:

- The operator's seat installed in the machine complies with ISO 7096.
- If the machine is used in accordance with regulations, the vibration values transmitted by the operator's seat are less than or equal to the tested excitation vibration for the relevant machine class in accordance with ISO 7096, Class EM3.
- The evaluated vibration acceleration " a_{zw} " values, measured in accordance with ISO 2631, Part 1 therefore comply with the requirements for protection against whole body vibration set out in EN 474-1.



Note

- ▶ When replacing a seat, only use original Liebherr operator seats with seat contact switch.

Turn the heater on:

- ▶ Set the rotary switch for blower 1 to stage 1.
 - ▷ Air is blown via vents into the operator's cab.

Turn the heater off:

- ▶ Set the rotary switch for blower 1 to stage 0.
 - ▷ The air flow is stopped.

Adjusting the temperature

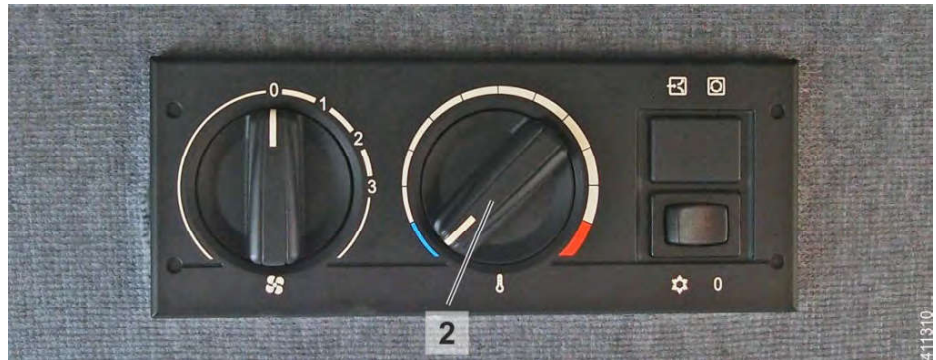

Fig. 225: Temperature control dial

Temperature regulation is continuous.

To increase the temperature:

- ▶ Turn the temperature control dial 2 in a clockwise direction.

To decrease the temperature:

- ▶ Turn the temperature control dial 2 in an anticlockwise direction.

Adjusting the blower force

The blower is turned on or off with the rotary switch blower 1.



Fig. 226: Rotary switches for blower

Blower stages:

- Stage 0 - position OFF
- Stage 1 - weak air flow
- Stage 2 - medium air flow
- Stage 3 - strong air flow

CLICK HERE TO **DOWNLOAD** THE COMPLETE MANUAL

- Thank you very much for reading the preview of the manual.
- You can download the complete manual from: www.heydownloads.com by clicking the link below



- Please note: If there is no response to CLICKING the link, please download this PDF first and then click on it.

CLICK HERE TO **DOWNLOAD** THE COMPLETE MANUAL



408429

Fig. 243: Check the back up alarm



WARNING

Risk of accident when backing up the machine!
When backing up, personnel near the machine may be overlooked.

- ▶ Always make a check personally to ensure that no one is being endangered when the machine is moved, even though a back up warning device is installed.
-
- ▶ Start the machine.
 - ▶ Switch the parking switch to travel position.
 - ▶ Deflect the travel joystick to the rear.
 - ▷ The back up alarm sounds.

3.2.19 Fire extinguisher (Option)

Mounting location of fire extinguisher

There is the option of retrofitting a fire extinguisher at the front on the right console of the operator's cab.



Fig. 244: Mounting location of fire extinguisher

- ▶ Contact Liebherr for the fire extinguisher installation kit.

LWT093517144/05/01.11.2017/en

411394

Adding diesel exhaust fluid

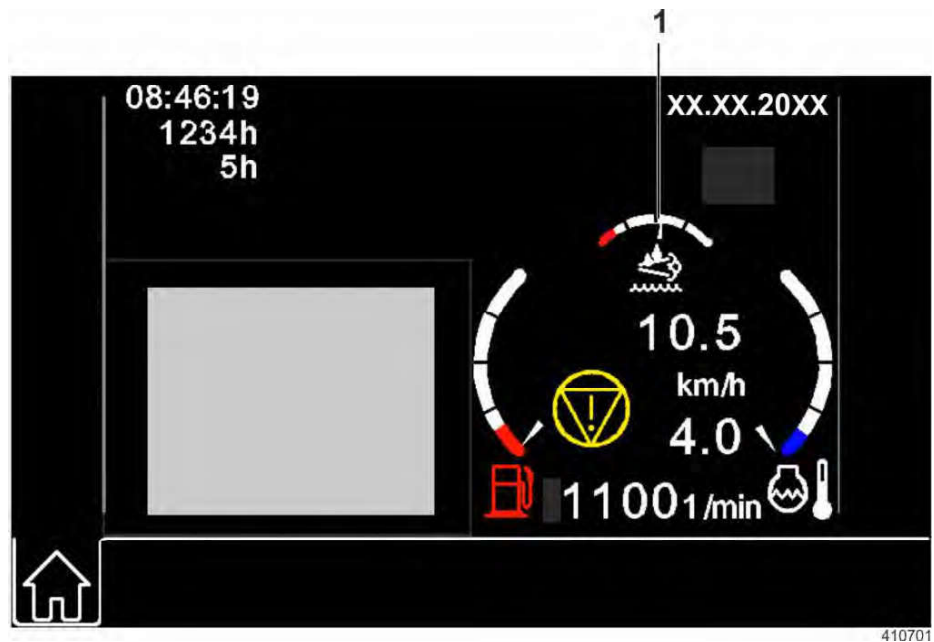

Fig. 261: Diesel exhaust fluid

- ▶ Set the starting switch to contact position.
- ▶ Check whether there is enough diesel exhaust fluid in the tank on the diesel exhaust fluid display.

NOTICE

Operation without diesel exhaust fluid!
The exhaust limit values specified by law are not adhered to.

- ▶ Operate the system **with** diesel exhaust fluid.
 - ▶ Top up diesel exhaust fluid in good time.
-



CAUTION

Diesel exhaust fluid can cause eye injuries and allergic skin reactions.

- ▶ Avoid skin contact with the diesel exhaust fluid.
 - ▶ Follow the manufacturer's instructions.
-

Preselecting the speed ranges

The machine is equipped with a rocker switch on the travel joystick for preselecting the travel speed.

By changing to position "I", the maximum achievable travel speed can be reduced. The maximum achievable travel speed is shown in the display unit.

The speed can also be selected during travel.

When shifting down from full travel speed, the machine is hydrostatically braked.



Fig. 277: Rocker switch - speed ranges

- ▶ Set the switch on the travel joystick to position "I", "II" or "III", depending on the working application.

Speed ranges - Basic setting

Full speed range

- ▶ Push the rocker switch on top - position "III"
 - ▷ Forward speed 0 km/h to 11 km/h
 - ▷ Reverse speed 0 km/h to 11 km/h

Medium speed range

- ▶ Rocker switch centre position - position "II"
 - ▷ Forward speed 0 km/h to 6 km/h
 - ▷ Reverse speed 0 km/h to 8 km/h

Low speed range

- ▶ Push the rocker switch down - position "I"
 - ▷ Forward speed 0 km/h to 4 km/h
 - ▷ Reverse speed 0 km/h to 4.5 km/h



Note

To make optimum use of machine power:

- ▶ Only carry out heavy pulling work with the machine in the low speed range - rocker switch position I as well as maximum 2 km/h.

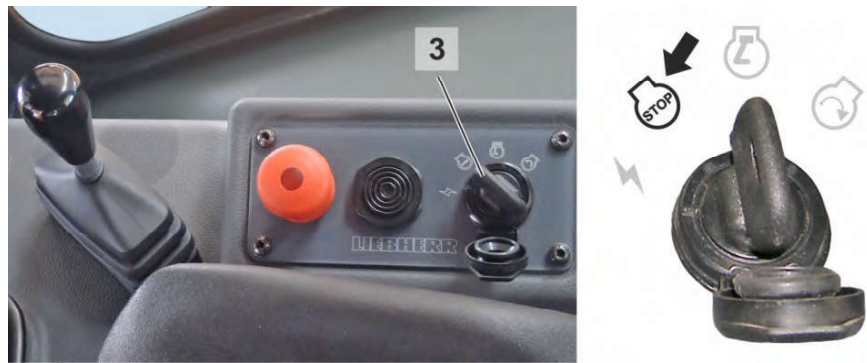

Fig. 295: Starting switch - zero position

- ▶ Turn the starting switch to zero position and pull the key off.
 - ▷ All indicator lights turn off.
 - ▷ The light on the battery main switch console lights up red.

Turning off the battery main switch

The battery main switch is on the right-hand side in the battery compartment.

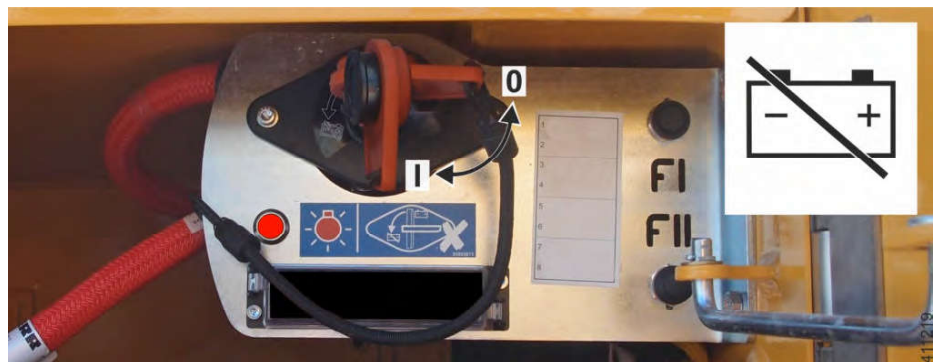

Fig. 296: Battery main switch

When the starting switch is set to zero position, the diesel exhaust fluid lines of the exhaust treatment system are automatically cleaned.

The light on the battery main switch console lights up red as long as the procedure is active.

The battery main switch may only be disconnected when the cleaning procedure is no longer active and the indicator light on the battery main switch console turns off.

NOTICE

The battery main switch is turned off during the active cleaning procedure of the exhaust treatment system!

Damage to the exhaust treatment system.

- ▶ Only turn off the battery main switch when the red indicator light on the battery main switch console turns off.

Before leaving the machine, turn the battery main switch off.

When the red indicator light turns off:

- ▶ Set the battery main switch to position "0".



Fig. 315: Removing the pin

- ▶ On the tilt cylinder, remove the retaining screw and the ring, and knock out the pin.



WARNING

Bores are aligned without tools using fingers!
Risk of crushed fingers and hands.

- ▶ Use suitable tools.

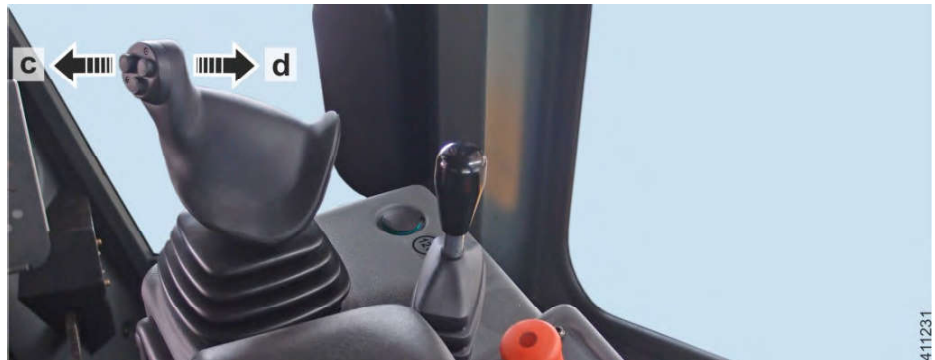

Fig. 316: Actuation of tilt cylinder

The cutting angle position must be pegged in the same position on both sides.

- ▶ Start the machine and move the tilt cylinder in the desired direction until the pin can be installed.

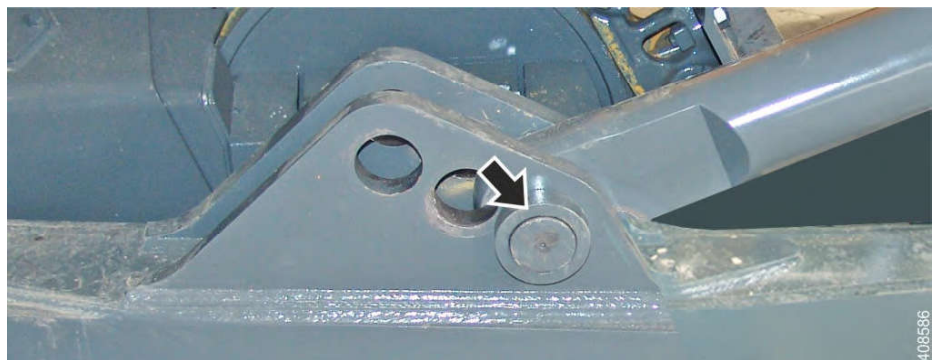

Fig. 317: Installing the pin

Regenerating diesel particle filter

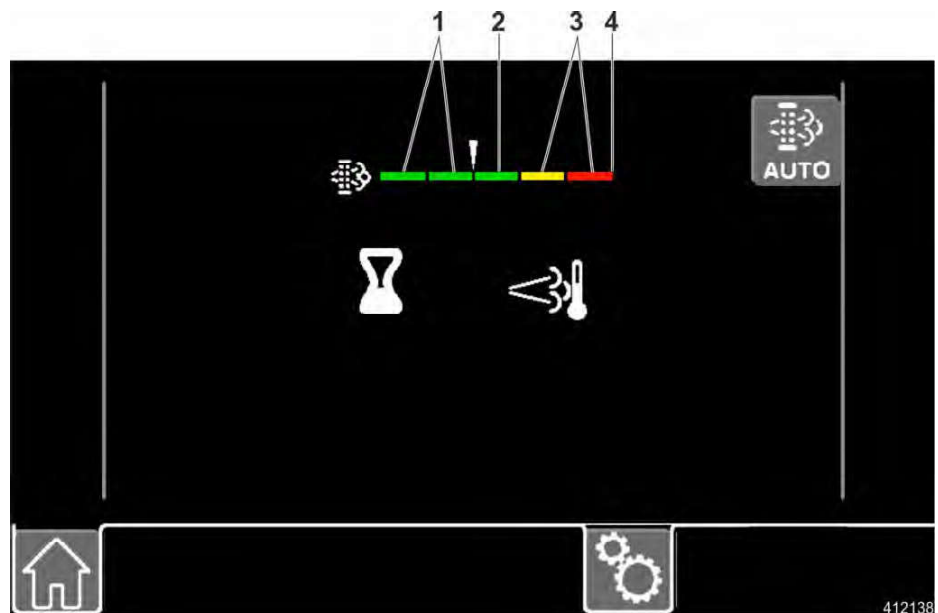







Fig. 335: Diesel particle filter load status

- | | |
|--|--|
| <p>1 Low load: regeneration not possible in automatic mode. Regeneration possible in manual mode.</p> <p>2 Medium load: regeneration possible in automatic and manual mode</p> | <p>3 High load: regeneration possible in manual mode</p> <p>4 100% load: contact Liebherr customer service</p> |
|--|--|

Symbol	Meaning	Notes
	Regeneration is performed resulting in high exhaust temperature.	If possible, do not shut down diesel engine. Automatic regeneration can be deactivated for use in areas where there is a risk of fire. Fuel saving during regeneration in normal work cycle.
	Active regeneration is deactivated. Observe load display.	For use in areas where there is a risk of fire or for work cycles with very low engine utilisation.
	Diesel particle filter is contaminated. "Manual" regeneration is to be performed within the next 2 operating hours (except PR716).	For regeneration, leave areas where there is a risk of fire.
 	Diesel particle filter is heavily contaminated. Reduced engine power is the result. "Manual" regeneration is to be performed immediately.	For regeneration, leave areas where there is a risk of fire.

LWT/93517144/05/01.11.2017/en

**DANGER**

Danger of accident due to toppling tree!

- ▶ As soon as the tree starts to fall, move back immediately.
- ▶ Do not drive on the rootstock.



Fig. 356: Felling the tree

- ▶ Slowly move toward the tree in the direction you want the tree to fall, with the blade raised.
- ▶ Move back as soon as the tree starts to fall.

Removing rootstocks

**CAUTION**

Rootstocks exceed the ground clearance of the machine!

- ▶ When driving on the terrain, pay attention to rootstocks and rock deposits which exceed the ground clearance of the machine.



Fig. 357: Removing the rootstock

- ▶ Move towards the tree stump with the blade below ground level.
- ▶ Tear it out of the ground by driving forward and simultaneously lifting the blade.

Embedding removed material

Removed material can be ripped out of the ground during dozing due to protruding parts, if the embedding depth is insufficient.

**WARNING**

The hydraulic system is under high pressure!
Disconnecting hydraulic lines and hoses which are under high pressure can cause hydraulic oil to escape at high pressure, leading to serious injuries.

- ▶ Do not disconnect lines, hoses, or adapters while the hydraulic system is under pressure.
- ▶ With the diesel engine turned off and the ignition turned on, actuate all functions again to relieve the pressure in the hydraulic lines.

- ▶ Set a suitable container under the connections.

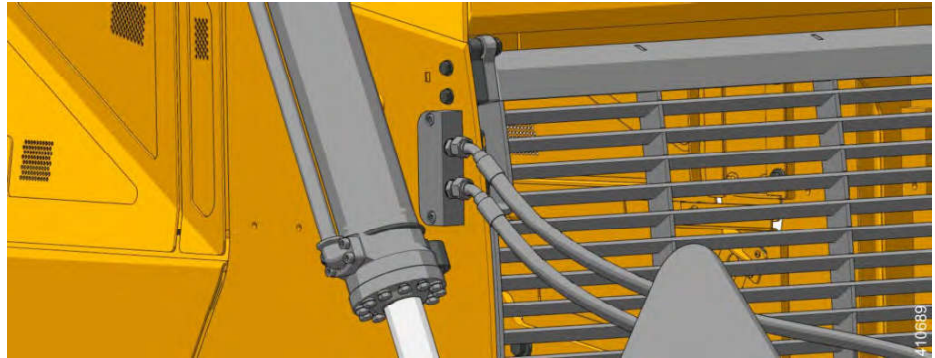

Fig. 377: Install the tilt lines

- ▶ Remove the union nut and locking cones and install the tilt lines.

**Note**

The tilt lines are mixed up at installation?
Tilting does not function as described in the Operating instructions.

- ▶ Install the tilt lines correctly.

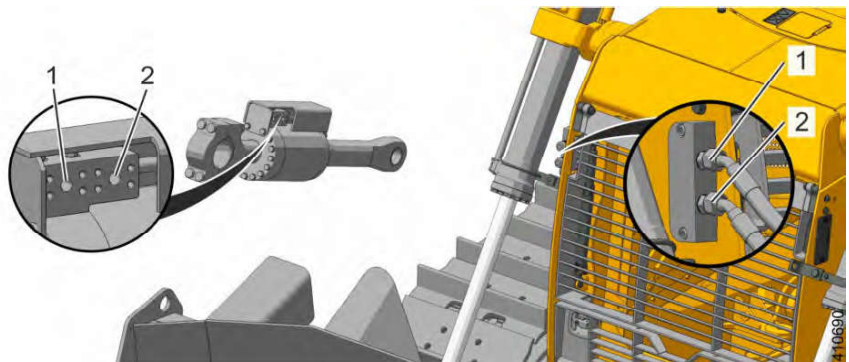

Fig. 378: Arrangement of tilt lines

1 Tilt cylinder front connection

2 Tilt cylinder rear connection

When towing, observe all specified safety regulations and the following recommendations:

- Keep the angle of the towing cable to the machine to a minimum. The maximum deviation from the machine's longitudinal axis is 30°.
- Approach and move the machine slowly and evenly. If the machine is moved unevenly, the towing cable or the rod may be overloaded and break off.
- When towing on slopes, the towing machine must be at least the same size as the one being towed. Power, weight and brake force of the towing machine must be adequate to keep both machines under control. If necessary, add a machine of the same size to the rear for braking purposes. (For more information see: 2.4.9 Safety guidelines for towing the machine, page 51)

Attachment points are provided on the front and on the rear of the machine for towing.

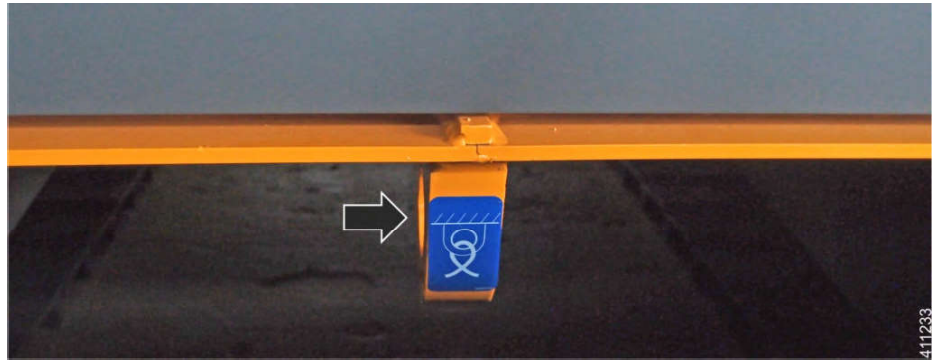

Fig. 396: Fastening point front

To tow the machine forward, use the front fastening point.

The fastening points are indicated by the information sign.

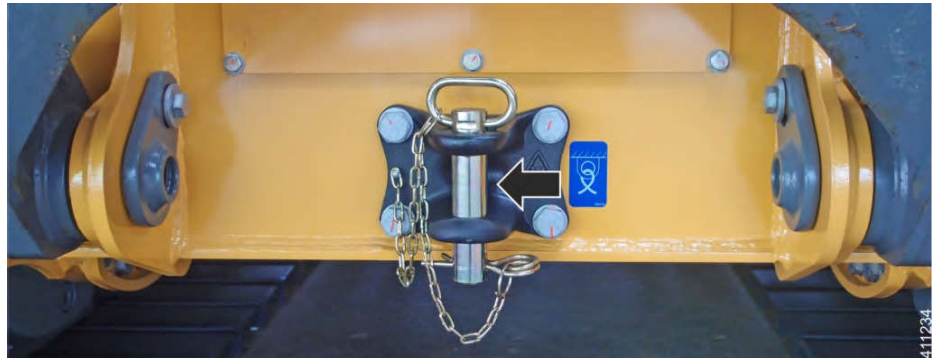

Fig. 397: Fastening point rear

The fastening point for towing the machine backward is the rear tow coupling.

- ▶ Attach the lifting tackle to the front or rear fastening point.

Towing the machine

The machine is equipped with a parking brake which is released by hydraulic pressure. The hydrostat acts as a service brake.

If the machine is disabled, the parking brake is actuated. The machine cannot be moved.

4.2 Problems - Cause - Remedy



4.2.1 Diesel engine

Malfunction / error	Cause	Remedy
The starter does not turn	Main fuse is turned off	Turn the fuse on
	Battery connections loose or corroded	Clean loose connections and tighten
	Battery voltage too low	Charge battery or replace it
	Starter current circuit interrupted or contacts corroded	Go to Liebherr Service
	Starter is defective	Go to Liebherr Service
The starter turns slowly	Battery voltage too low	Charge battery or replace it
	Battery connections loose or corroded	Clean loose connections and tighten
	Ambient temperatures too low	Observe the measures for winter operation
The Diesel engine does not start or stops right away	Fuel tank empty	Refuel, vent the fuel system
	Fuel filter plugged up	Replace the fuel filter
	Fuel line, pre-cleaner or strainer in fuel tank plugged up	Clean and vent the fuel system
	Fuel system or filter leaks	Reseal and vent
	Air in fuel system	Vent the fuel system
	Fuel not cold resistant	Clean preliminary filter, replace fuel filter; use winter fuel
	Ambient temperatures too low	Observe the measures for winter operation
	Heat flange defective (in cold temperatures)	Check heat flange and replace if necessary
Diesel engine is hard to start	Leaks or insufficient pressure in the fuel low pressure circuit	Check for leaks (visual inspection); have inspected by Liebherr Service
	Diesel engine compression too low	Go to Liebherr Service
	Heat flange defective (in cold temperatures)	Check heat flange and replace if necessary
	Problem in electronic	Read out error stack from engine control unit, go to Liebherr Service
Diesel engine turns off unintentionally	Power supply interrupted	Go to Liebherr Service
	Leaks or insufficient pressure in the fuel low pressure circuit	Check for leaks (visual inspection); have inspected by Liebherr Service
	Problem in electronic	Read out error stack from engine control unit, go to Liebherr Service

LWT93517144/05/01.11.2017/en

Fuse	Value	Unit	Name / Function
F26	1	A	Digital input module logic supply
F27	3	A	Digital input module sensor supply
F28	3	A	Reversing warning device ^{A)}
F29	5	A	PME indicating unit
F30	10	A	Master PME
F31	1	A	Master Awake-Signal
F32	3	A	Horn
F33	3	A	Travel sensor
F34	1	A	Tank sensor
F35	30	A	Operator's cab
F36	30	A	ECU power supply
F37	10	A	Air pump
F38	1	A	ECU power supply
F39	3	A	ECU power supply
F41	3	A	NOx sensor
F45	3	A	NH3 sensor
F46	15	A	Heating and air conditioning unit
F47	10	A	Machine socket 24 V
F48	3	A	Engine compartment illumination headlight
F49	3	A	Operator's cab lighting
F50	3	A	Engine diagnostics plug
F51	5	A	Transformer
F52	15	A	Fuel water separator heating ^{A)}
F54	3	A	LITU1 ^{A)}
F55	3	A	LITU1 ^{A)}
F56	10	A	Supply for options
F57	10	A	Supply for options
F58	3	A	Coolant solenoid valve
F59	1	A	DCU ^{A)}
F60	25	A	Terminal 30 ^{A)}
F61	5	A	Blade release position pressure switch
F62	2	A	Blade release position plug base bridge
F63	1	A	Blade release position
F64	3	A	Solenoid blade release position
F65	5	A	Blade release position solenoid valves
F95	3	A	Close 6-way blade solenoid valve ^{A)}
F96	3	A	Close 6-way blade solenoid valve ^{A)}

LWT093517144/05/01.11.2017/en

Name	Recommended fuel and operating fluid	Symbol	Quantity
Diesel exhaust fluid tank	Diesel exhaust fluid according to Standard ISO 22241 / DIN 70070		50 l
Windscreen washer system	Standard windscreen washer fluid or denatured alcohol		9.5 l
Air conditioning unit refrigerant	R134a		1250 g
Refrigerant oil in the air conditioning compressor			200 cm ³

Tab. 22

5.2.3 Lubrication chart

The lubrication chart serves as an overview of the location of maintenance points on the machine and their inspection intervals.

This provides detailed information regarding:

- the completion of maintenance tasks, see section “Maintenance and inspection schedule” and “Maintenance tasks.”
- the required lubricants and fuels, see section “Lubricants and fuels.”
- the required filling quantities. (For more information see: [5.2.1 Recommended lubricants, page 258](#))

If a machine is operated less than 1000 hours per year, then an oil sample must be taken once a year. Hydraulic oil with longer use in the machine should be changed at least after four years (mineral oils and fully saturated synthetic ester) as well as no later than after six years (Liebherr Plus oils).

If a machine is not in use for longer than six month without a break, then an oil analysis is required before putting the machine back into service.

Oil analysis

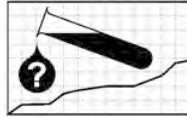

Liebherr recommends to have the oil analyzed regularly by OELCHECK and to carry out the oil change according to the lab report:

- yellow set for biodegradable hydraulic oils
- green set for mineral oils

See also Service and product information.

Reasons for regular oil analysis:

- Cost savings due to longer oil change intervals.
- Information about hydraulic system, components and media
- Environmental and resource protection

Oil sample removal / application condition	
	Oil sample removal on machines in normal application
	Oil sample removal on machines in dust intensive application
The frequency of taking the oil sample depends on the application conditions.	

Tab. 37: Legend: Oil sample removal depending on application condition

Oil grade	Oil sample removal			
	no bio use (oil analysis optional)		Bio use (oil analysis required)	
Liebherr Mineral oil	every 1000 h	every 250 h	--B)	_B)
Liebherr Hydraulic HVI				
Liebherr Hydraulic Basic 68				
Liebherr Hydraulic Basic 100				
Liebherr-PAO A)	every 1000 h	every 250 h	first at 0 h, then every 1000 h	first at 0 h, then every 250 h
Liebherr Hydraulic Plus				
Liebherr Hydraulic Plus Arctic				
Third party product - Mineral oil	first at 1000 h, then every 500 h	every 250 h	--B)	_B)
Third party product - Fully saturated synthetic ester	_B)	_B)	first at 0 h, then every 500 h	first at 0 h, then every 250 h

Tab. 38: Oil sample removal depending on application condition

LWT/93517144/05/01.11.2017/en

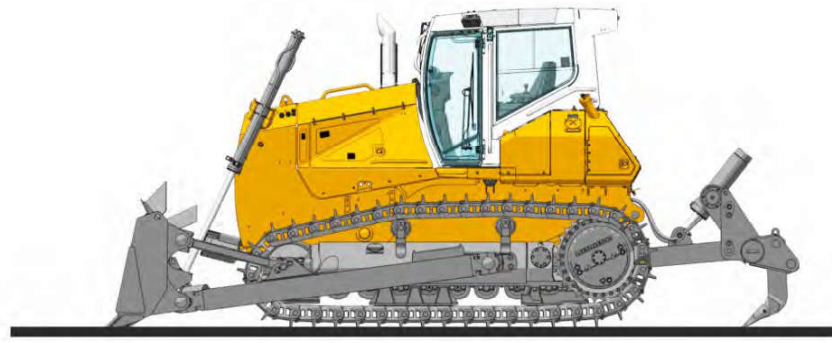

408943

Fig. 455: Maintenance position

- ▶ Set the machine down on level ground.
- ▶ Lower the working attachment to the ground.

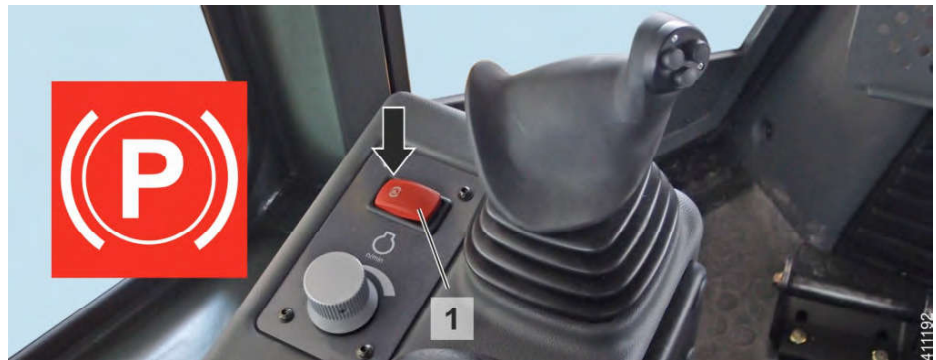

411192

Fig. 456: Park position parking switch

- ▶ Switch the parking switch 1 to park position.
- ▶ Turn diesel engine off.
- ▶ Remove the ignition key.

Turning off the battery main switch

The battery main switch is on the right-hand side in the battery compartment.



411219

Fig. 457: Battery main switch

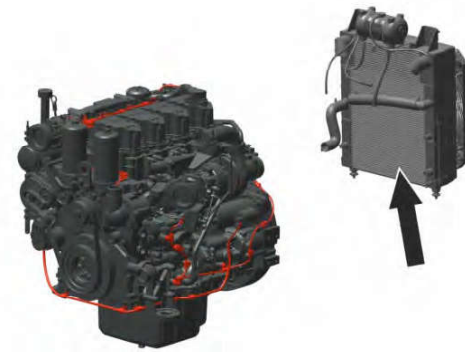

410752

Fig. 469: Cooler

- Clean the cooler units with compressed air, steam or water.

Cleaning the cooling system with swivel-mounted fan (option)

The available option of a swivel-mounted fan simplifies the cleaning and checking procedure of the cooling system and the fan.



Fig. 470: Open the snap locks

- To open the cooler guard, open the snap closures 1 at the bottom on the cooler guard.



WARNING

Falling guard due to defective gas cylinder!

- Check if the gas cylinders ensure the fully opened position.

NOTICE

Dust is drawn in via the intake line!
The diesel engine may be damaged as a result.

- ▶ Never operate the machine without an air filter.

-
- ▶ Install the safety element and the main filter element. Ensure correct seating.

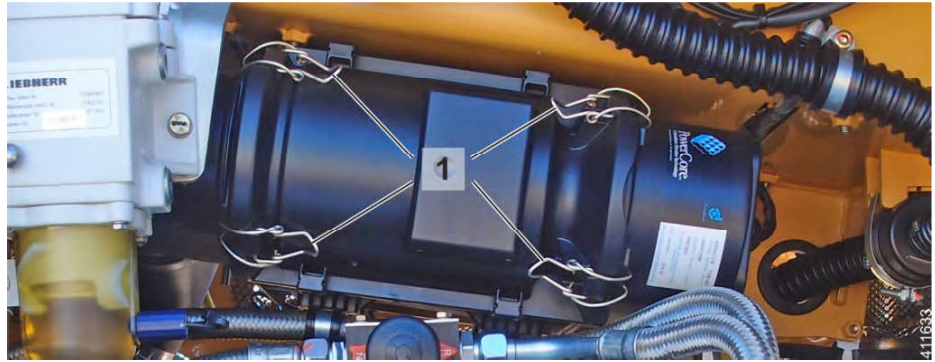

Fig. 490: Close the mounting clamps

- ▶ Clean the service cover and fit it on to the filter housing in the correct position.

The mounting clamps can only be closed without force if the service cover is touching the filter housing all around the circumference.

- ▶ Close the mounting clamps.

Troubleshooting

The filter cover cannot be locked?

The filter cover is not installed in the correct position:

- ▶ The recess on the filter cover must match the notch on the filter.
-

5.16 Track components

5.16.1 Checking the nuts and bolts of the travel gear components are firmly seated

Ensure that following requirements are met:

- A torque wrench is available.

Check the tightening torque

- ▶ Check the fastening bolts on the track pads and sprocket segments visually for looseness.



Fig. 502: Tightening torque

- ▶ Check the tightening torques.

Tightening torques for track pad bolts (re-check)

Made by BERCO	
Size	Tightening torque
3/4" - 16 UNF	630 +/- 20 Nm
7/8" - 14 UNF	850 +/- 10 Nm
M24 x 1.5	1020 +/- 30 Nm
M27 x 2	1913 +/- 49 Nm
1" - 14 UNF	1400 +/- 30 Nm

Tab. 47: Tightening torque for BERCO items

Made by INTERTRAC	
Size	Tightening torque
3/4" - 16 UNF	640 +/- 30 Nm

Tab. 48: Tightening torque for Intertrac items

- ▶ Loosen loose bolts and the surrounding bolts and retighten.

NOTICE

The pin is not seated evenly on the ring!
The retaining ring can be damaged when knocking it in.

- ▶ Before knocking the pin in, check if the pin is placed evenly on the ring.

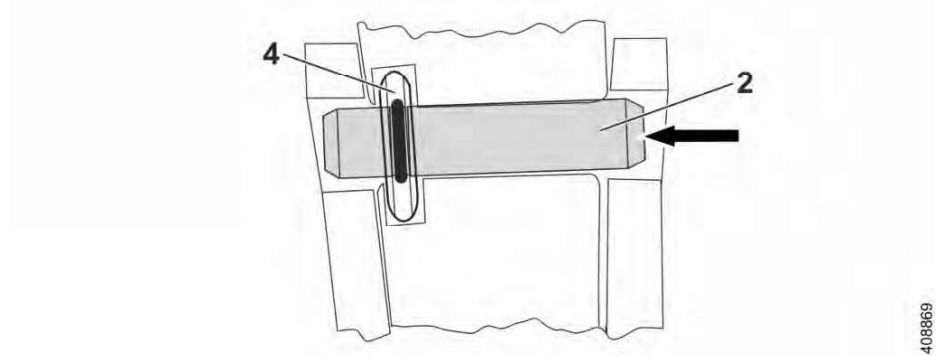

Fig. 516: Knock in the pin

- ▶ Knock the pin **2** in with a metered, not too hard blow of the hammer.
 - ▷ The pin snaps in on the ring **4**.

CLICK HERE TO **DOWNLOAD** THE COMPLETE MANUAL

- Thank you very much for reading the preview of the manual.
- You can download the complete manual from: www.heydownloads.com by clicking the link below



- Please note: If there is no response to CLICKING the link, please download this PDF first and then click on it.

CLICK HERE TO **DOWNLOAD** THE COMPLETE MANUAL