

en

Operator's manual

Material handling machine

Document ID

	ORIGINAL OPERATOR'S MANUAL
Order number:	12219536
Issued:	2020-08-27
Version:	01
Author:	LHB / Technical Documentation Department

Product ID

Manufacturer:	Liebherr-Hydraulikbagger GmbH
Type:	LH 50 M Litronic
Type no.:	1216
From Serial no.:	89799

Contact

Liebherr-Hydraulikbagger GmbH
Liebherrstraße 12
D – 88457 Kirchdorf/Iller

CLICK HERE TO **DOWNLOAD** THE COMPLETE MANUAL

- Thank you very much for reading the preview of the manual.
- You can download the complete manual from: www.heydownloads.com by clicking the link below



- Please note: If there is no response to CLICKING the link, please download this PDF first and then click on it.

CLICK HERE TO **DOWNLOAD** THE COMPLETE MANUAL

3	Control and operation	63
3.1	Control and operating elements	63
3.1.1	Overview of operator's platform	63
3.1.2	Control unit A	65
3.1.3	Control unit B	66
3.1.4	Further control units	66
3.1.5	Symbols on control description sticker	67
3.2	Display	75
3.2.1	Display	75
3.2.2	Status symbols	76
3.2.3	Start page menu	89
3.2.4	Camera menu	90
3.2.5	Air conditioning	91
3.2.6	Operating status menu	93
3.2.7	Diesel particulate filter submenu (option)	94
3.2.8	Sensor-controlled low idle automatic and automatic engine stop submenu (option)	95
3.2.9	System settings menu	96
3.2.10	Operating hour meter and odometer submenu	97
3.2.11	Windscreen wiper interval submenu	97
3.2.12	Radio remote control submenu	98
3.2.13	Display settings submenu	99
3.2.14	Display brightness and display volume submenu	99
3.2.15	Camera image contrast submenu	100
3.2.16	Camera return time submenu	100
3.2.17	Regional settings and system parameters submenu	101
3.2.18	Unit selection submenu	101
3.2.19	System diagnosis submenu	102
3.2.20	Time zone submenu	102
3.2.21	Time format and date format submenu	103
3.2.22	Language selection submenu	103
3.2.23	Electrical outputs submenu	104
3.2.24	Electrical inputs submenu	105
3.2.25	Function settings menu	105
3.2.26	Central lubrication system submenu (option)	107

Reliability

Durability and Sustainability –
Quality Down to the Last Detail

Comfort

Perfection at a Glance –
When Technology is Comfortable

Maintainability

Efficiency Bonus – Even with
Maintenance and Service



LH 40 M – Equipment GA14

Industry – Kinematic 2A

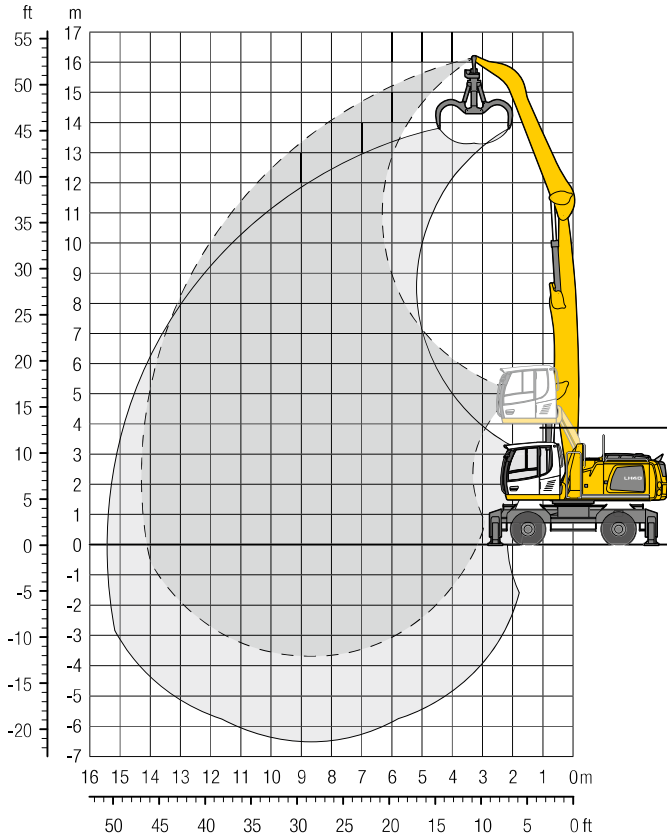

Operating Weight

The operating weight includes the basic machine with 4 point outriggers, hydr. cab elevation, 8 solid tyres plus intermediate rings, straight boom 8,60 m, angled stick 6,00 m and multi-tine grab GM 70C/0.80 m³ semi-closed tines.

Weight 38,500 kg

Dimensions

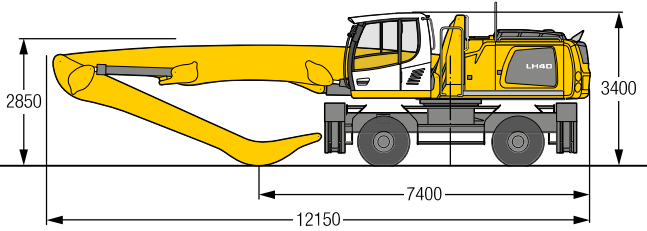

m	Undercarriage	4.5 m		6.0 m		7.5 m		9.0 m		10.5 m		12.0 m		13.5 m		15.0 m		16.5 m		18.0 m		m			
		Stabilizers raised	4 pt. outriggers down	Stabilizers raised	4 pt. outriggers down	Stabilizers raised	4 pt. outriggers down	Stabilizers raised	4 pt. outriggers down	Stabilizers raised	4 pt. outriggers down	Stabilizers raised	4 pt. outriggers down	Stabilizers raised	4 pt. outriggers down	Stabilizers raised	4 pt. outriggers down	Stabilizers raised	4 pt. outriggers down	Stabilizers raised	4 pt. outriggers down				
15.0	Stabilizers raised			8.2*	8.2*																	7.3*	7.3*	6.4	
	4 pt. outriggers down			8.2*	8.2*																		7.3*	7.3*	
13.5	Stabilizers raised			9.5	9.8*	6.5	8.3																4.8	6.1*	8.8
	4 pt. outriggers down			9.8*	9.8*	8.4*	8.4*																6.1*	6.1*	
12.0	Stabilizers raised					6.7	8.2*	4.8	6.2														3.5	4.6	10.5
	4 pt. outriggers down					8.2*	8.2*	7.3*	7.3*														5.5*	5.5*	
10.5	Stabilizers raised					6.7	8.1*	4.9	6.3	3.6	4.7												2.9	3.8	11.7
	4 pt. outriggers down					8.1*	8.1*	7.2*	7.2*	6.5*	6.5*												5.1*	5.1*	
9.0	Stabilizers raised					6.6	8.2*	4.8	6.2	3.6	4.7	2.7	3.7										2.4	3.3	12.6
	4 pt. outriggers down					8.2*	8.2*	7.2*	7.2*	6.5*	6.5*	5.8	5.8*										4.9*	4.9*	
7.5	Stabilizers raised			9.2	10.0*	6.4	8.2	4.7	6.0	3.5	4.6	2.7	3.6										2.1	2.9	13.3
	4 pt. outriggers down			10.0*	10.0*	8.5*	8.5*	7.4*	7.4*	6.5*	6.5*	5.8	5.8*										4.8	4.8*	
6.0	Stabilizers raised	12.8*	12.8*	8.5	10.6*	6.0	7.8	4.4	5.8	3.4	4.5	2.6	3.5	2.1	2.8								1.9	2.7	13.8
	4 pt. outriggers down	12.8*	12.8*	10.6*	10.6*	8.8*	8.8*	7.6*	7.6*	6.6*	6.6*	5.7	5.9*	4.6	5.2*								4.5	4.8*	
4.5	Stabilizers raised	11.8	15.0*	7.7	10.2	5.5	7.3	4.1	5.5	3.2	4.3	2.5	3.4	2.0	2.8								1.8	2.5	14.1
	4 pt. outriggers down	15.0*	15.0*	11.4*	11.4*	9.2*	9.2*	7.8*	7.8*	6.7*	6.7*	5.6	5.9*	4.6	5.1*								4.2	4.7*	
3.0	Stabilizers raised	9.9	13.9	6.8	9.2	5.0	6.7	3.8	5.1	3.0	4.1	2.4	3.3	1.9	2.7								1.7	2.5	14.3
	4 pt. outriggers down	15.0*	15.0*	12.0*	12.0*	9.6*	9.6*	8.0*	8.0*	6.6	6.8*	5.4	5.9*	4.5	5.0*								4.1	4.4*	
1.5	Stabilizers raised	5.5*	5.5*	6.0	8.4	4.5	6.2	3.5	4.8	2.8	3.9	2.3	3.2	1.9	2.6								1.7	2.4	14.3
	4 pt. outriggers down	5.5*	5.5*	12.3*	12.3*	9.7*	9.7*	8.0*	8.0*	6.4	6.8*	5.3	5.8*	4.4	4.8*								4.1	4.1*	
0	Stabilizers raised	5.0*	5.0*	5.5	7.9	4.2	5.9	3.3	4.6	2.7	3.7	2.2	3.1	1.8	2.6								1.7	2.4	14.1
	4 pt. outriggers down	5.0*	5.0*	12.0*	12.0*	9.6*	9.6*	7.8	7.8*	6.2	6.6*	5.2	5.5*	4.4*	4.4*								3.7*	3.7*	
-1.5	Stabilizers raised	5.8*	5.8*	5.3	7.6	4.0	5.6	3.1	4.4	2.6	3.6	2.1	3.0										1.8	2.6	13.4
	4 pt. outriggers down	5.8*	5.8*	10.9*	10.9*	8.9*	8.9*	7.3*	7.3*	6.1*	6.1*	4.9*	4.9*										3.7*	3.7*	
-3.0	Stabilizers raised			5.2	7.5	3.9	5.5	3.1	4.4	2.5	3.6												2.2	3.2	11.5
	4 pt. outriggers down			9.0*	9.0*	7.7*	7.7*	6.4*	6.4*	5.2*	5.2*												4.4*	4.4*	

Height Can be slewed through 360° In longitudinal position of undercarriage Max. reach * Limited by hydr. capacity

The lift capacities on the stick end without attachment are stated in metric tons (t) and are valid on a firm, level supporting surface with blocked oscillating axle. These capacities can be slewed through 360° with the undercarriage in the transverse position. Capacities in the longitudinal position of the undercarriage (+/- 15°) are specified over the steering axle with the stabilizers raised and over the rigid axle with the stabilizers down. Indicated loads based on the ISO 10567 standard and do not exceed 75% of tipping or 87% of hydraulic capacity. The lift capacity values indicated are attained at the corresponding operating temperature. This operating temperature is ensured by continuous movement of the boom. Weights of fitted attachments (grabs, load hooks, etc.) and load accommodation attachment are to be deducted from the lift capacity values. The lift capacity of the unit is limited by its stability, the lifting capability of the hydraulic elements, or the maximum permissible lifting capacity of the load hook.

In accordance with the harmonised European Standard EN 474-5, hydraulic excavators used for lifting operations must be equipped with pipe fracture safety valves, an overload warning device, a load hook and a lift capacity chart.

LH 50 M – Equipment GKG14

Industry – Kinematic 2A

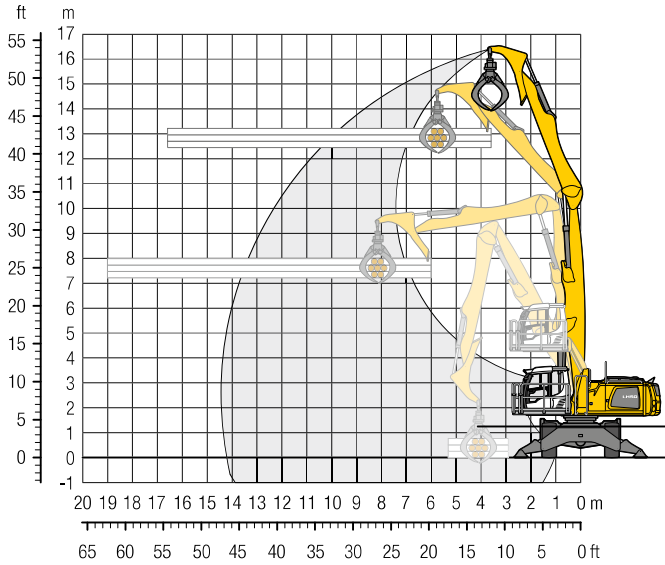

Operating Weight

The operating weight includes the basic machine with 4 point outriggers, hydr. cab elevation, 4 solid tyres, straight boom 7,60 m, slick 5,80 m with counterstay and wood grab 0,70 m².

Weight 43,400 kg

Dimensions

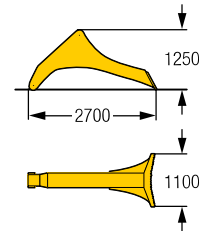
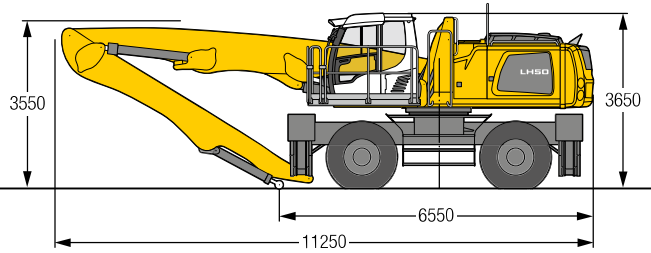

m	Undercarriage	4.5 m		6.0 m		7.5 m		9.0 m		10.5 m		12.0 m		13.5 m		15.0 m		16.5 m		18.0 m		m	
		Stabilizers raised	4 pt. outriggers down	Stabilizers raised	4 pt. outriggers down	Stabilizers raised	4 pt. outriggers down	Stabilizers raised	4 pt. outriggers down	Stabilizers raised	4 pt. outriggers down	Stabilizers raised	4 pt. outriggers down	Stabilizers raised	4 pt. outriggers down	Stabilizers raised	4 pt. outriggers down	Stabilizers raised	4 pt. outriggers down	Stabilizers raised	4 pt. outriggers down	Stabilizers raised	4 pt. outriggers down
15.0				7.6*	7.6*																5.6*	5.6*	7.3
13.5						7.3*	7.3*	5.5*	5.5*												4.6*	4.6*	9.4
12.0						7.9*	7.9*	6.0*	7.0*	4.4	5.1*										4.0	4.1*	10.9
10.5						7.7*	7.7*	6.1	7.0*	4.5	5.8	3.3	4.0*								3.3	3.8*	12.1
9.0						7.8*	7.8*	6.1	7.0*	4.5	5.8	3.4	4.5								2.8	3.6*	12.9
7.5						8.0*	8.0*	5.9	7.1*	4.4	5.8	3.4	4.5	2.6	3.5						2.5	3.5	13.6
6.0						8.0*	8.0*	7.1*	7.1*	6.5*	6.5*	5.9*	5.9*	3.8*	3.8*						3.5*	3.5*	14.0
4.5						8.4*	8.4*	5.7	7.3	4.3	5.6	3.3	4.4	2.6	3.5						2.3	3.2	14.3
3.0						10.5	10.7*	7.3	9.0*	5.4	7.0	4.1	5.4	3.2	4.3	2.5	3.4				2.2	3.0	14.4
1.5						10.7*	10.7*	9.0*	9.0*	7.7*	7.7*	6.8*	6.8*	6.1*	6.1*	5.4*	5.4*				3.5*	3.5*	14.4
0						14.9	15.4*	9.5	11.8*	6.8	8.9	5.0	6.7	3.9	5.2	3.0	4.1	2.4	3.3		2.1	3.0	14.4
-1.5						15.4*	15.4*	11.8*	11.8*	9.6*	9.6*	8.1*	8.1*	7.0*	7.0*	6.2*	6.2*	5.3*	5.3*		3.6*	3.6*	14.4
-3.0						13.0	17.4*	8.6	11.6	6.2	8.3	4.7	6.3	3.7	4.9	2.9	4.0	2.3	3.3		2.1	2.9	14.2
-4.5						17.4*	17.4*	12.8*	12.8*	10.1*	10.1*	8.4*	8.4*	7.2*	7.2*	6.2*	6.2*	5.2*	5.2*		3.7*	3.7*	14.2
						11.7	12.1*	7.8	10.8	5.7	7.8	4.4	6.0	3.5	4.7	2.8	3.9	2.3	3.2		2.1	3.0	13.5
						12.1*	12.1*	13.3*	13.3*	10.4*	10.4*	8.5*	8.5*	7.1*	7.1*	6.0*	6.0*	4.8*	4.8*		3.9*	3.9*	12.1
						9.3*	9.3*	7.3	10.2	5.4	7.4	4.2	5.7	3.3	4.6	2.7	3.8	2.3	3.2		2.2	3.2	8.4
						9.3*	9.3*	13.1*	13.1*	10.3*	10.3*	8.4*	8.4*	6.9*	6.9*	5.6*	5.6*	4.0*	4.0*		3.9*	3.9*	
						9.3*	9.3*	7.1	10.0	5.2	7.2	4.0	5.6	3.2	4.5	2.7	3.7				2.6	3.7	
						9.3*	9.3*	12.0*	12.0*	9.5*	9.5*	7.7*	7.7*	6.1*	6.1*	4.6*	4.6*				4.4	6.1	
								5.1	7.2	7.9*	7.9*										6.9*	6.9*	

Height Can be slewed through 360° In longitudinal position of undercarriage Max. reach * Limited by hydr. capacity

The lift capacities on the stick end without attachment are stated in metric tons (t) and are valid on a firm, level supporting surface with blocked oscillating axle. These capacities can be slewed through 360° with the undercarriage in the transverse position. Capacities in the longitudinal position of the undercarriage (+/- 15°) are specified over the steering axle with the stabilizers raised and over the rigid axle with the stabilizers down. Indicated loads based on the ISO 10567 standard and do not exceed 75% of tipping or 87% of hydraulic capacity. The lift capacity values indicated are attained at the corresponding operating temperature. This operating temperature is ensured by continuous movement of the boom. Weights of fitted attachments (grabs, load hooks, etc.) and load accommodation attachment are to be deducted from the lift capacity values. The lift capacity of the unit is limited by its stability, the lifting capability of the hydraulic elements, or the maximum permissible lifting capacity of the load hook.

In accordance with the harmonised European Standard EN 474-5, hydraulic excavators used for lifting operations must be equipped with pipe fracture safety valves, an overload warning device, a load hook and a lift capacity chart.

Technical Data



Diesel Engine

Rating per ISO 9249	155 kW (211 HP) at 1,800 RPM
Model	Liebherr D934
Type	4 cylinder in-line
Bore/Stroke	122/150 mm
Displacement	7.0 l
Engine operation	4-stroke diesel Common-Rail turbo-charged and after-cooled reduced emissions
Air cleaner	dry-type air cleaner with pre-cleaner, primary and safety elements sensor controlled
Engine idling	sensor controlled
Electrical system	
Voltage	24 V
Batteries	2 x 180 Ah/12 V
Alternator	three-phase current 28 V/140 A
Stage IV	
Harmful emissions values	in accordance with 97/68/EG stage IV
Emission control	Liebherr-SCR technology
Fuel tank	460 l
Urea tank	65 l
Stage IIIA	
Harmful emissions values	in accordance with 97/68/EG stage IIIA
Fuel tank	460 l



Cooling System

Diesel engine	water-cooled compact cooling system consisting cooling unit for water, hydraulic oil and charge air with stepless thermostatically controlled fan
----------------------	--



Hydraulic Controls

Power distribution	via control valves with integrated safety valves, simultaneous actuation of chassis and attachment. Swing drive in separate closed circuit
Servo circuit	
Attachment and swing	with electro-hydraulic pilot control and proportional joystick levers
Chassis	
Mobile	electroproportional via foot pedal
Crawler	with electric proportionally functioning foot pedals or adjusted with plugable levers
Additional functions	via switch or electroproportional foot pedals
Proportional control	proportionally acting transmitters on the joysticks for additional hydraulic functions



Hydraulic System

Hydraulic pump	
for attachment and travel drive	2 Liebherr axial piston variable displacement pumps (double construction) Max. flow 2 x 237 l/min. Max. pressure 350 bar
for swing drive	reversible axial piston variable displacement pump, closed-loop circuit Max. flow 144 l/min. Max. pressure 370 bar
Hydraulic pump regulation and control	2 circuit Liebherr-Synchron-Comfort-system (LSC) with electronic engine speed sensing regulation, pressure and flow compensation, automatic oil flow optimizer
Hydraulic tank	285 l
Hydraulic system	585 l
Hydraulic oil filter	1 main return filter with integrated partial micro filtration (5 µm)
MODE selection	adjustment of engine and hydraulic performance via a mode pre-selector to match application, e.g. for especially economical and environmentally friendly operation or for maximum material handling and heavy-duty jobs
S (Sensitive)	mode for precision work and lifting through very sensitive movements
E (Eco)	mode for especially economical and environmentally friendly operation
P (Power)	mode for high performance with low fuel consumption
P+ (Power-Plus)	mode for highest performance and for very heavy duty applications, suitable for continuous operation
Engine speed and performance setting	stepless alignment of engine output and hydraulic power via engine speed
Option	Tool Control: ten preadjustable pump flows and pressures for add on tools



Swing Drive

Drive	Liebherr axial piston motor in a closed system, Liebherr planetary reduction gear
Swing ring	Liebherr, sealed race ball bearing swing ring, internal teeth
Swing speed	0 – 7.5 RPM stepless 0 – 4,5 RPM stepless (High Rise)
Swing torque	84 kNm
Holding brake	wet multi-disc (spring applied, pressure released)
Option	pedal controlled positioning swing brake

LH 40 M - Attachment GA16

Industry – Kinematic 2A

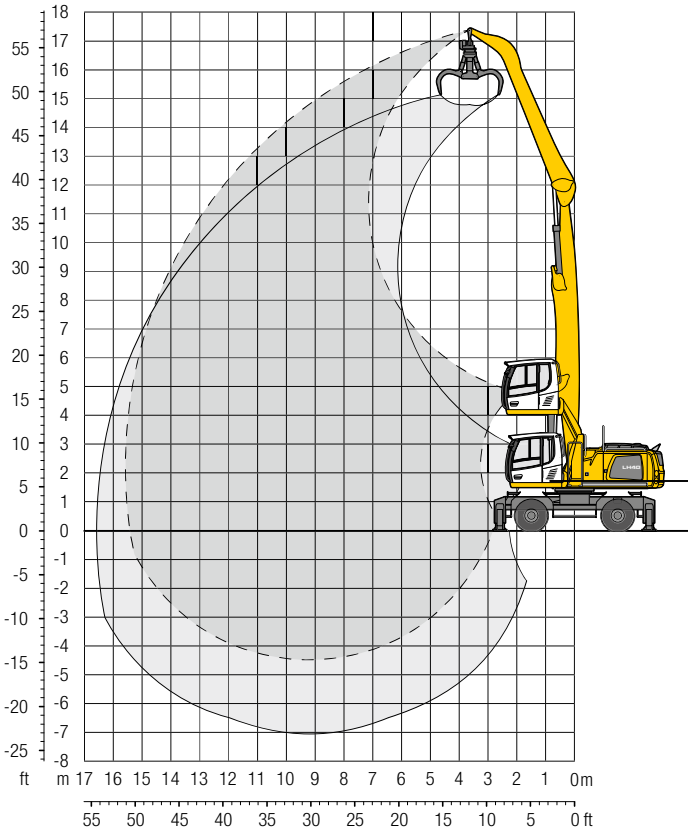

Operating Weight

The operating weight includes the basic machine with 4 point outriggers, hydr. cab elevation, 8 solid tyres plus intermediate rings, straight boom 9.10 m, angled stick 6.80 m and grab model GM 65/0.60 m³ semi-closed tines.

Weight 38,500 kg

Dimensions

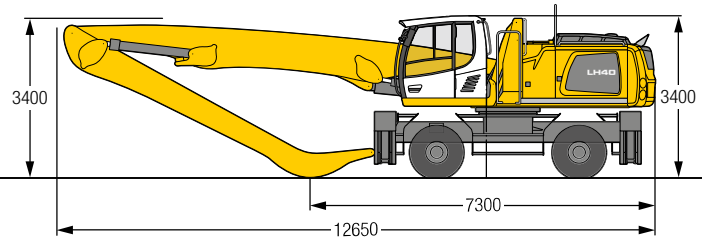

m	Undercarriage	4.5 m		6.0 m		7.5 m		9.0 m		10.5 m		12.0 m		13.5 m		15.0 m		16.5 m		18.0 m		m		
		Stabilizers raised	4 pt. outriggers down	Stabilizers raised	4 pt. outriggers down	Stabilizers raised	4 pt. outriggers down	Stabilizers raised	4 pt. outriggers down	Stabilizers raised	4 pt. outriggers down	Stabilizers raised	4 pt. outriggers down	Stabilizers raised	4 pt. outriggers down	Stabilizers raised	4 pt. outriggers down	Stabilizers raised	4 pt. outriggers down	Stabilizers raised	4 pt. outriggers down	Stabilizers raised	4 pt. outriggers down	
16.5	Stabilizers raised 4 pt. outriggers down			7.4* 7.4*	7.4* 7.4*																	7.0* 7.0*	7.0* 7.0*	6.2
15.0	Stabilizers raised 4 pt. outriggers down					6.6 7.6*	7.6* 7.6*															4.7 5.6*	5.6* 5.6*	8.9
13.5	Stabilizers raised 4 pt. outriggers down					7.0 7.9*	7.9* 7.9*	5.0 6.9*	6.4 6.9*	3.6 5.5*	4.7 5.5*											3.4 4.9*	4.4 4.9*	10.8
12.0	Stabilizers raised 4 pt. outriggers down					7.1 7.7*	7.7* 7.7*	5.1 6.8*	6.5 6.8*	3.8 6.1*	4.9 6.1*	2.8 5.0*	3.7 5.0*									2.7 4.6*	3.6 4.6*	12.2
10.5	Stabilizers raised 4 pt. outriggers down					7.0 7.7*	7.7* 7.7*	5.1 6.8*	6.5 6.8*	3.8 6.1*	4.9 6.1*	2.8 5.5*	3.8 5.5*									2.2 4.3*	3.0 4.3*	13.2
9.0	Stabilizers raised 4 pt. outriggers down					6.9 7.9*	7.9* 7.9*	5.0 6.9*	6.4 6.9*	3.7 6.1*	4.8 6.1*	2.8 5.5*	3.8 5.5*	2.1 4.7	2.9 5.0*							1.9 4.2*	2.6 4.2*	14.0
7.5	Stabilizers raised 4 pt. outriggers down			9.5 9.6*	9.6* 9.6*	6.6 8.1*	8.1* 8.1*	4.8 7.0*	6.2 7.0*	3.6 6.2*	4.7 6.2*	2.8 5.5*	3.7 5.5*	2.1 4.7	2.9 5.0*							1.7 4.0	2.4 4.1*	14.7
6.0	Stabilizers raised 4 pt. outriggers down	9.9* 9.9*	9.9* 9.9*	8.8 10.2*	10.2* 10.2*	6.1 8.4*	7.9 8.4*	4.5 7.2*	5.9 7.2*	3.4 6.3*	4.5 6.3*	2.6 5.6*	3.5 4.6	2.0 5.0*	2.8 4.6	1.6 3.8	2.2 4.3*					1.5 3.8	2.2 4.1*	15.1
4.5	Stabilizers raised 4 pt. outriggers down	12.1 14.4*	14.4* 14.4*	7.8 10.9*	10.3 10.9*	5.5 8.8*	7.3 8.8*	4.1 7.4*	5.5 7.4*	3.2 6.4*	4.3 6.4*	2.5 5.5*	3.4 5.6*	1.9 4.5	2.7 5.0*	1.5 3.8	2.2 4.3*					1.4 3.6	2.1 4.0*	15.4
3.0	Stabilizers raised 4 pt. outriggers down	10.0 15.7*	14.0 15.7*	6.8 11.6*	9.2 11.6*	4.9 9.2*	6.7 9.2*	3.7 7.6*	5.1 7.6*	2.9 6.5*	4.0 6.5*	2.3 5.3	3.2 5.6*	1.8 4.4	2.6 4.9*	1.5 3.7	2.1 4.2*					1.3 3.5	2.0 3.8*	15.6
1.5	Stabilizers raised 4 pt. outriggers down	5.0* 5.0*	5.0* 5.0*	5.8 11.9*	8.2 11.9*	4.4 9.4*	6.1 9.4*	3.4 7.7*	4.7 7.7*	2.7 6.3	3.7 6.5*	2.1 5.2	3.0 5.6*	1.7 4.3	2.5 4.8*	1.4 3.7	2.1 4.0*					1.3 3.5	2.0 3.5*	15.6
0	Stabilizers raised 4 pt. outriggers down	4.2* 4.2*	4.2* 4.2*	5.2 11.5*	7.5 11.5*	3.9 9.3*	5.6 9.3*	3.1 7.6	4.4 7.6*	2.5 6.1	3.5 6.4*	2.0 5.0	2.9 5.4*	1.6 4.2	2.4 4.6*	1.4 3.6*	2.0 3.6*					1.3 3.2*	2.0 3.2*	15.4
-1.5	Stabilizers raised 4 pt. outriggers down	4.7* 4.7*	4.7* 4.7*	4.8 9.7*	7.1 9.7*	3.6 8.8*	5.3 8.8*	2.9 7.2*	4.2 7.2*	2.3 5.9	3.4 6.1*	1.9 4.9	2.8 5.1*	1.6 4.1*	2.4 4.1*	1.4 3.6*	2.0 3.6*					1.4 3.1*	2.1 3.1*	14.8
-3.0	Stabilizers raised 4 pt. outriggers down			4.7 9.3*	7.0 9.3*	3.5 7.8*	5.1 7.8*	2.7 6.5*	4.0 6.5*	2.2 5.4*	3.3 5.4*	1.8 4.5*	2.7 4.5*									1.6 3.4*	2.3 3.4*	13.5
-4.5	Stabilizers raised 4 pt. outriggers down																							

Height Can be slewed through 360° In longitudinal position of undercarriage Max. reach * Limited by hydr. capacity

The lift capacities on the stick end without attachment are stated in metric tons (t) and are valid on a firm, level supporting surface with blocked oscillating axle. These capacities can be slewed through 360° with the undercarriage in the transverse position. Capacities in the longitudinal position of the undercarriage (+/- 15°) are specified over the steering axle with the stabilizers raised and over the rigid axle with the stabilizers down. Indicated loads based on the ISO 10567 standard and do not exceed 75% of tipping or 87% of hydraulic capacity. The lift capacity values indicated are attained at the corresponding operating temperature. This operating temperature is ensured by continuous movement of the boom. Weights of fitted working tools (grabs, load hooks, etc.) and load accommodation equipment are to be deducted from the lift capacity values. The lift capacity of the unit is limited by its stability, the lifting capability of the hydraulic elements, or the maximum permissible lifting capacity of the load hook.

In accordance with the harmonised European Standard EN 474-5, hydraulic excavators used for lifting operations must be equipped with pipe fracture safety valves, an overload warning device, a load hook and a lift capacity chart.

LH 40 C – Attachment GA14

Industry – Kinematic 2A

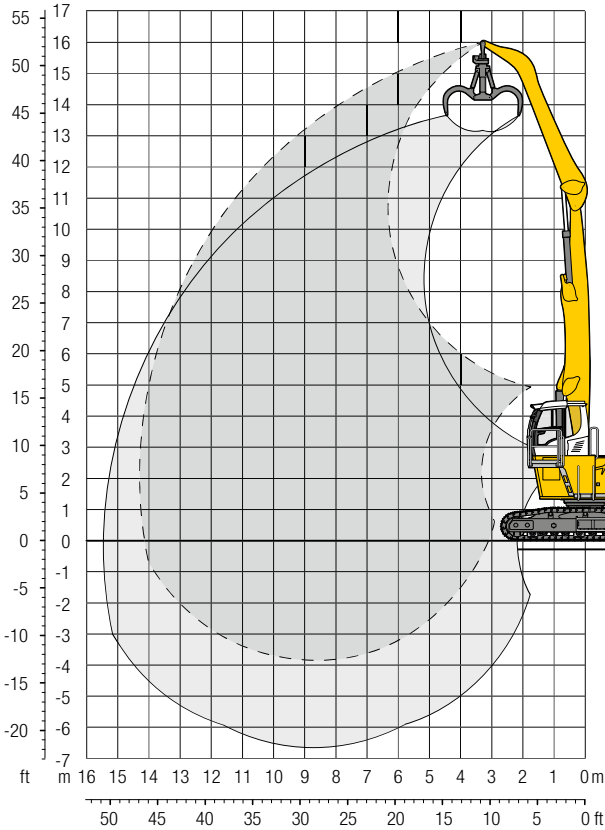

Operating Weight and Ground Pressure

The operating weight includes the basic machine with rigid cab elevation, straight boom 8.60 m, angled stick 6.00 m and grab model GM 70C/0.80 m³ semi-closed tines.

Weight	40,100 kg
Pad width	600 mm
Ground pressure	on request

Dimensions

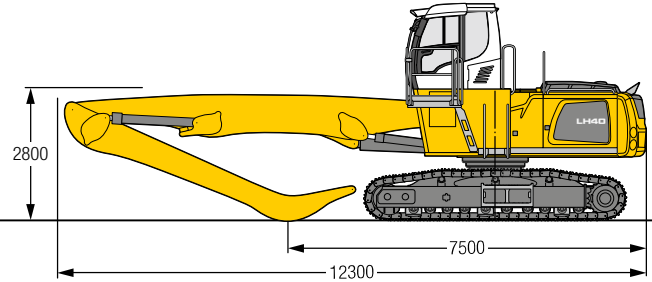

Height m	Undercarriage	4.5 m		6.0 m		7.5 m		9.0 m		10.5 m		12.0 m		13.5 m		15.0 m		m		
		Can be slewed through 360°	In longitudinal position of undercarriage	Can be slewed through 360°	In longitudinal position of undercarriage	Can be slewed through 360°	In longitudinal position of undercarriage	Can be slewed through 360°	In longitudinal position of undercarriage	Can be slewed through 360°	In longitudinal position of undercarriage	Can be slewed through 360°	In longitudinal position of undercarriage	Can be slewed through 360°	In longitudinal position of undercarriage					
16.5	EW																			
15.0	EW			7.8*	7.8*													7.6*	7.6*	6.1
13.5	EW			9.7*	9.7*	8.2*	8.2*											6.2*	6.2*	8.6
12.0	EW					8.2*	8.2*	7.3*	7.3*									5.5*	5.5*	10.3
10.5	EW					8.1*	8.1*	7.2*	7.2*	6.5*	6.5*							5.2*	5.2*	11.6
9.0	EW					8.2*	8.2*	7.2*	7.2*	6.5*	6.5*	5.8*	5.8*					4.9*	4.9*	12.5
7.5	EW			10.0*	10.0*	8.4*	8.4*	7.3*	7.3*	6.5*	6.5*	5.8*	5.8*					4.8*	4.8*	13.2
6.0	EW	12.4*	12.4*	10.6*	10.6*	8.8*	8.8*	7.5*	7.5*	6.6*	6.6*	5.8	5.9*	4.7	5.2*			4.6	4.8*	13.8
4.5	EW	14.9*	14.9*	11.3*	11.3*	9.2*	9.2*	7.8*	7.8*	6.7*	6.7*	5.6	5.9*	4.7	5.1*			4.3	4.8*	14.1
3.0	EW	16.3*	16.3*	12.0*	12.0*	9.5*	9.5*	7.9*	7.9*	6.7	6.8*	5.5	5.9*	4.6	5.0*			4.2	4.5*	14.3
1.5	EW	5.7*	5.7*	12.3*	12.3*	9.7*	9.7*	8.0*	8.0*	6.5	6.8*	5.4	5.8*	4.5	4.8*			4.2*	4.2*	14.3
0	EW	4.9*	4.9*	12.1*	12.1*	9.6*	9.6*	7.8	7.9*	6.3	6.6*	5.3	5.5*	4.4*	4.4*			3.8*	3.8*	14.1
-1.5	EW	5.6*	5.6*	11.0*	11.0*	9.0*	9.0*	7.4*	7.4*	6.1*	6.1*	5.0*	5.0*					3.7*	3.7*	13.5
-3.0	EW			9.3*	9.3*	7.8*	7.8*	6.5*	6.5*	5.3*	5.3*							4.3*	4.3*	11.8
-4.5	EW																			

Height
 Can be slewed through 360°
 In longitudinal position of undercarriage
 Max. reach
 * Limited by hydr. capacity

The lift capacities on the stick end without attachment are stated in metric tons (t) and can be slewed through 360° on a firm, level supporting surface. Capacities are valid for 600 mm wide triple grouser pads (resp. flat pads). Indicated loads based on the ISO 10567 standard and do not exceed 75% of tipping or 87% of hydraulic capacity. The lift capacity values indicated are attained at the corresponding operating temperature. This operating temperature is ensured by continuous movement of the boom. Weights of fitted working tools (grabs, load hooks, etc.) and load accommodation equipment are to be deducted from the lift capacity values. The lift capacity of the unit is limited by its stability, the lifting capability of the hydraulic elements, or the maximum permissible lifting capacity of the load hook.

In accordance with the harmonised European Standard EN 474-5, hydraulic excavators used for lifting operations must be equipped with pipe fracture safety valves, an overload warning device, a load hook and a lift capacity chart.

Engine type	Nominal power	High idle rpm	Code	97/68/EC stage	CO ₂ emissions during NRSC testing or RMC testing under standard laboratory conditions	CO ₂ emissions during NRTC testing with warm start under standard laboratory conditions
TCD 3.6 L4 DOC-DPF / SCR	95 kW	2000 min ⁻¹	CFVI95BU	IV	691.21 g/kWh	705.07 g/kWh

Tab. 2: CO₂ emissions of stage IV diesel engine

Engine type	Nominal power	High idle rpm	Code	97/68/EC stage	CO ₂ emissions during NRSC testing or RMC testing under standard laboratory conditions	CO ₂ emissions during NRTC testing with warm start under standard laboratory conditions
D924 A7-05	129 kW	2200 min ⁻¹	F4HFE414F*V	V	685.00 g/kWh	692.15 g/kWh
D936 A7-25	300 kW	1900 min ⁻¹	R06LW7105	V	677.80 g/kWh	697.15 g/kWh
D944 A7-25	200 kW	1900 min ⁻¹	R04KW7102	V	718.49 g/kWh	753.40 g/kWh
D944 A7-25	220 kW	1900 min ⁻¹	R04KW7101	V	713.58 g/kWh	742.31 g/kWh
D946 A7-25	330 kW	1900 min ⁻¹	R06KW7101	V	675.80 g/kWh	674.52 g/kWh
D956 A7-05	340 kW	2100 min ⁻¹	R06NW7104	V	704.788 g/kWh	758.30 g/kWh
D9508 A7-05	455 kW	1900 min ⁻¹	V08MW7102	V	724.83 g/kWh	739.75 g/kWh
TCD 3.6 L4 EKZ 199	95 kW	2000 min ⁻¹	C5VI95BU	V	697.15 g/kWh	742.95 g/kWh

Tab. 3: CO₂ emissions of stage V diesel engine

Test conditions:

- NRSC / RMC: Stationary test cycle for mobile machines and equipment not intended for road traffic / ramped mode cycle. "Stationary test cycle" refers to a test cycle where the speed and the torque of the engine assume a limited number of nominally constant values; stationary tests are either single-phase test cycles or ramped mode cycles.
- NRTC: Non-stationary test for mobile machines and equipment not intended for road traffic. "Non-stationary test cycle" refers to a test cycle where the standardised speed and torque values change every second.

1.2.3 Sound level

The sound values of the machine are specified in the technical data.

The guaranteed sound power level (L_{WA}) is measured according to Directive 2000/14/EC.

The sound pressure level (L_{pA}) is measured according to ISO 6396. The measuring inaccuracy is defined in this standard.

2.3.7 Refrigeration technician

Responsibility

The refrigeration technician is responsible for the following:

- Read operator's manual.
- Read supplied documentation.
 - Operator's manuals for components
 - Operator's manuals from third party manufacturers
 - Additional instructions
- Maintain and repair machine for safe and reliable function.
- Execute all maintenance tasks and repair tasks specified for the refrigeration technician in the maintenance and inspection schedule.
- Isolate battery main switch of power supply system and secure it against switching on again.
- Clearly define and label working position.
- Wear personal protective equipment.
- Use tools suitable for the work deployment.
- Adhere to safety regulations at place of use.
- Report all changes to machine that affect safety to operating company.
- Exclusively perform retrofittings of machine after consultation with manufacturer.
- Use original Liebherr spare parts wherever possible.

Requirement

The refrigeration technician has following qualification and skills:





- Has completed the legally specified minimum age.
- Is physically and mentally capable of maintaining the machine.
 - Satisfactory eyesight
 - Satisfactory hearing ability
 - Quick reactions
 - Is able to estimate distance, height and gaps.
- The refrigeration technician has completed training that complies with the country-specific laws, standards and guidelines.
- The refrigeration technician has following skills:
 - Is able to assess work correctly.
 - Is able to recognise dangers.
 - Is able to take safety measures.
- Has knowledge and experience of the relevant field of activity.
- Knows the relevant national standards.
- Has the necessary authorisation for maintenance and repair of machine.
- Knows the machine and the hazards.
- Knows all procedures and precautions for maintenance.
- Has knowledge of handling special tools for maintenance and repair.
- Is not under any physical or mental impairment that limits one of the prescribed requirements.
- Is not under the influence of alcohol.
- Is not under the influence of drugs.

2.3.8 Slinger

Responsibility

The slinger is responsible for the following:

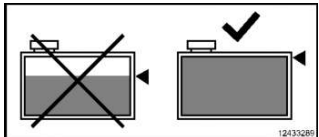
- Wear personal protective equipment.
- Choose correct and undamaged slinging gear.

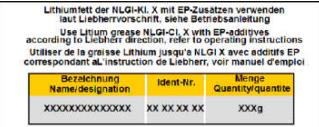
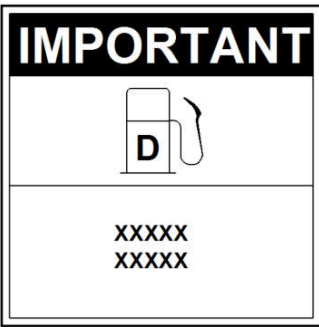
Position	Sign	Description
23		Lifting point Applies to machines with indicated lifting points on counterweight and gooseneck boom. Indicates lifting points on counterweight. Indicates lifting points on gooseneck boom.
24		Entry prohibited Do not enter marked areas.
25		Coolant specifications Indicates fill level.
26		Coolant Identifies prescribed coolant. Read notes in operator's manual.
27		Grease specifications Read notes in operator's manual. Indicates specified grease.
28		Fuel tank Read notes in operator's manual. Indicates maximum permitted sulphur content in fuel.

LHB/122 19536/01/2020-06-z7/en

2.7.4 Access to machine

Injury

Incorrect entry and exit

- Uppercarriage and undercarriage are positioned so that steps and ladders are aligned with each other.
- Clean dirt, oil, ice and snow from steps, ladders, anti-slip mats, handrails and handles.
- Enter and exit carefully on muddy roads, ice, snow, traffic on access roads and in narrow conditions.
- Regularly check steps, ladders, anti-slip mats, handrails and handles and have them repaired if necessary.
- Before entering machine, clean mud, grease, ice and snow from shoes and climbing aids.
- Put on gloves for secure grip.
- Do not climb up or down using tyres, wheel hubs or rims.
- When exterior influences (for example wind) make opening and closing the door more difficult: Always guide door with your hand.
- Make sure that the opened or closed door has engaged properly.
- If the machine is still moving: Do not stand up from the operator's seat.
- Never jump off machine.
- Enter and leave the machine exclusively using the access system.
- Do not use control elements as handles.
- Keep your face towards machine during entry and exit.
- Make sure you always have two hands and a foot or two feet and one hand in contact with the access system.
- After entering the operator's cab, find out about emergency exit.

If the machine has a cab elevation:

- Climb until the door is reached.
- When you reach door handle with your free hand: Open door.
- Continue climbing.

Adhere to safety instructions on entry and exit in operator's manual of complete machine:

- If the uppercarriage is mounted on a support.
- If the machine is part of a system.
- If the uppercarriage is mounted on a pontoon or rail guide system.

3 Control and operation

3.1 Control and operating elements

3.1.1 Overview of operator's platform











Note

Different machine configuration!









- ▶ Adhere to control description sticker.
-

Height-adjustable cab

Symbol	Description	Symbol	Description
	Activating height-adjustable cab		Lowering operator's cab
	Raising operator's cab		Lowering operator's cab
	Raising operator's cab		Lifting hydraulically tiltable cab
	Raising operator's cab		Lowering hydraulically tiltable cab
	Lowering operator's cab		



Tab. 15: Height-adjustable cab

Wheeled excavator travel mode

Symbol	Description	Symbol	Description
	Travel brake		Travelling left
	Increasing traction in automatic mode		Turning left
	Travelling forward		Travelling right
	Travelling backwards		Turning right

Tab. 16: Wheeled excavator travel mode











Crawler excavator travel mode

Symbol	Description	Symbol	Description
	Extending side frames		Travelling left

Symbol	Meaning
	Ride control switched on

Tab. 22: Status symbols of travel mode

Slewing gear

Symbol	Meaning
	Slewing brake inoperative
	Slewing gear blocked
	Slew limitation active
	Slew limitation bypassed, slew limitation switched off
	Virtual left wall bypassed
	Virtual right wall bypassed
	Uppercarriage aligned parallel to undercarriage; machine in travel position
	Slewing gear; neutral position required
	Main movements of working attachment and slewing gear blocked
	Main movements of working attachment and slewing gear; neutral position required
	Slewing alarm deactivated

Replacing the display in case of sensor failure

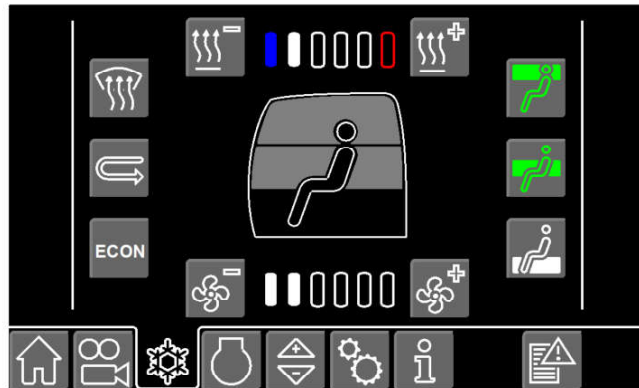

Fig. 384: Display in case of sensor failure

Sensor failure of air conditioning leads to following changes to the display:

- Functions are hidden.
- Set temperature is displayed as bar chart display.

If sensor of air conditioning has failed:

- ▶ Contact Liebherr customer service.

Sunshine sensor

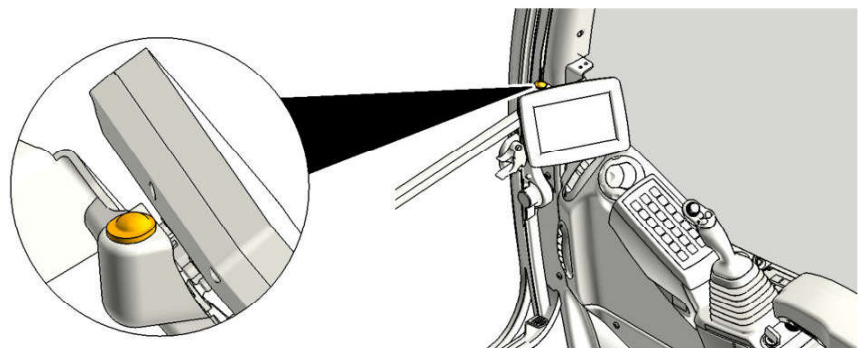



Fig. 385: Position of sunshine sensor

- ▶ Make sure that sunshine sensor is not covered.
- ▶ Make sure that sunshine sensor is not damaged.

3.2.6 Operating status menu

Menu call: 

The display of this submenu varies depending on machine configuration:

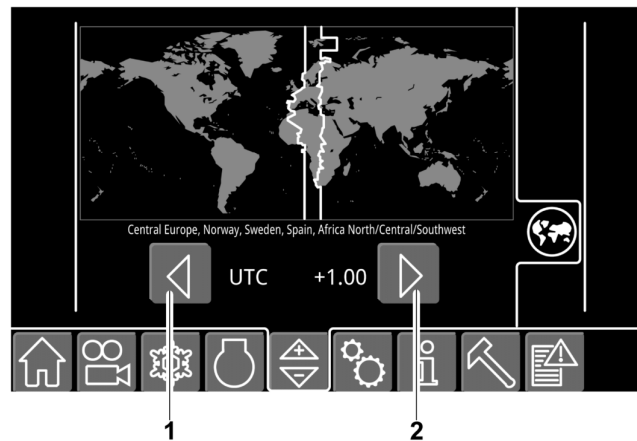

Fig. 417: Time zone submenu

1 Moving time zone to west button 2 Moving time zone to east button

3.2.21 Time format and date format submenu

Menu call:  >  > 

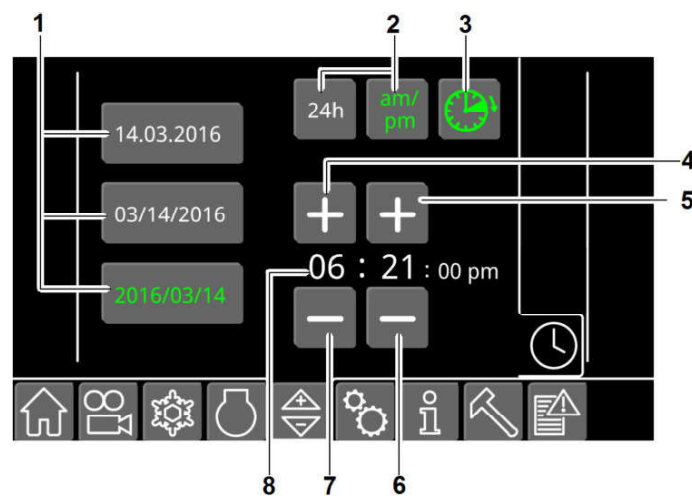

Fig. 418: Time format and date format submenu

- | | | | |
|---|-----------------------------------|---|---------------------------------|
| 1 | Date format buttons | 5 | Setting minutes forward button |
| 2 | Time format buttons | 6 | Setting minutes backward button |
| 3 | Summer time or winter time button | 7 | Setting hours backward button |
| 4 | Setting hours forward button | 8 | Set time format |

- ▶ Select time format and date format: Press corresponding buttons.
- ▷ Selected time format and date format are displayed in green.

3.2.22 Language selection submenu

Menu call:  >  > 

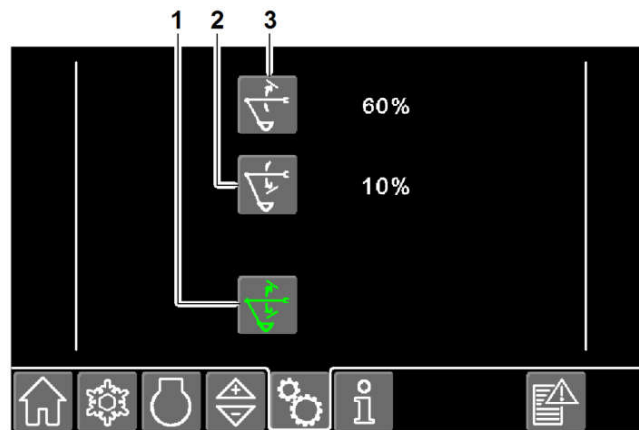

Fig. 456: Hoist cylinder shut-off submenu

- | | | | |
|---|---|---|-----------------------------|
| 1 | Activating hoist cylinder shut-off button | 3 | Upper shut-off point button |
| 2 | Lower shut-off point button | | |

► Activate hoist cylinder shut-off: (For more information see: [3.5.2 Hoist cylinder shut-off \(option\)](#), page 195)

3.2.32 Stick cylinder shut-off and hoist cylinder shut-off submenu (option)

Menu call: >

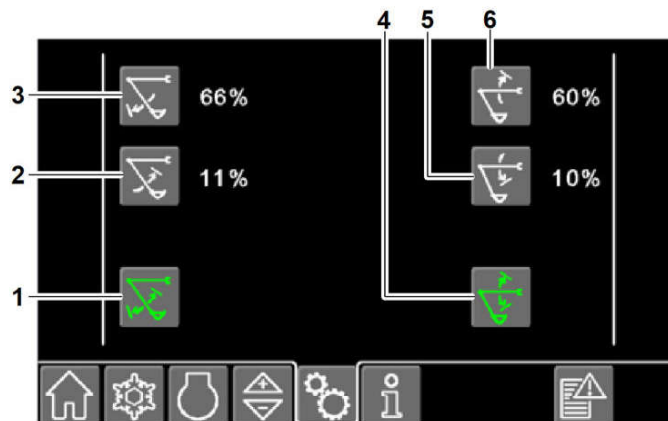

Fig. 457: Stick cylinder shut-off and hoist cylinder shut-off submenu

- | | | | |
|---|---|---|---|
| 1 | Activating stick cylinder shut-off button | 4 | Activating hoist cylinder shut-off button |
| 2 | Upper shut-off point button | 5 | Lower shut-off point button |
| 3 | Lower shut-off point button | 6 | Upper shut-off point button |

The display of symbols varies depending on machine configuration.

In machines without *activating stick cylinder shut-off* button 1 the stick cylinder shut-off is always activated.

3.3.2 Entering and exiting machine



WARNING

Incorrect entry and exit!
Fall.

- ▶ Enter and leave machine exclusively using climbing aids.
- ▶ Do not use control elements as handles.
- ▶ Never jump off machine.

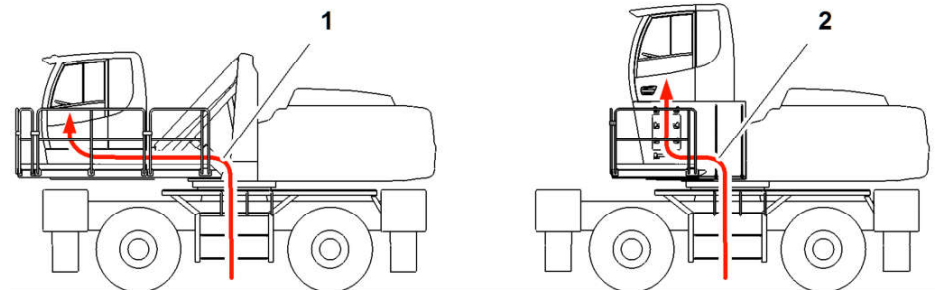

Fig. 482: Access to operator's cab

1 Access for height adjustable cab

2 Access for rigid operator's cab

Entering machine

If machine is equipped with step lighting:

- ▶ Switch on step lighting. (For more information see: [3.3.3 Step lighting \(option\), page 124](#))
- ▶ Turn upper body and face to ladder.
- ▶ Make sure you always have two hands and a foot or two feet and one hand in contact with the ladder.
- ▶ Enter machine via climbing aids.
- ▶ Open cab door.
- ▶ Enter operator's cab.
- ▶ Adjust operator's seat and steering wheel.
- ▶ Close cab door.

Exiting machine

- ▶ Park machine. (For more information see: [3.8 Parking machine, page 240](#))
- ▶ Align uppercarriage parallel to undercarriage.

If machine is not equipped with platform or walkway:

- ▶ Slowly swivel uppercarriage to the right until climbing aid is visible.
- ▶ Leave operator's cab.
- ▶ Close cab door.

Closing lower windscreen

- ▶ Unlock lower windscreen: Press levers of locking mechanism **1** together simultaneously.
- ▶ Pull lower windscreen downwards until it engages.
- ▶ Simultaneously turn extender wheels **2** downwards.

Upper windscreen

NOTICE

Windscreen collides with steering wheel!
Damage to windscreen.

- ▶ Make sure that steering column is swivelled away from windscreen during opening and closing.

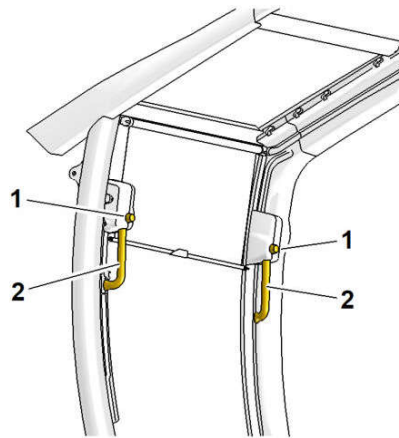

Fig. 530: Upper windscreen

1 Knob

2 Handle

Opening upper windscreen

Make sure the following preconditions are met:

- Steering column is swivelled away from windscreen.
- ▶ Unlock upper windscreen: Press knobs **1** simultaneously.
- ▶ Push upper windscreen upwards with handles **2** and pull back until it engages in roof of operator's cab.
- ▶ Swivel steering column into working position.

Closing upper windscreen

Make sure the following preconditions are met:

- Steering column is swivelled away from windscreen.
- ▶ Unlock upper windscreen: Press knobs **1** simultaneously.
- ▶ Pull upper windscreen forwards and downwards with handles **2** until it engages in front in operator's cab.
- ▶ Swivel steering column into working position.

CLICK HERE TO **DOWNLOAD** THE COMPLETE MANUAL

- Thank you very much for reading the preview of the manual.
- You can download the complete manual from: www.heydownloads.com by clicking the link below



- Please note: If there is no response to CLICKING the link, please download this PDF first and then click on it.

CLICK HERE TO **DOWNLOAD** THE COMPLETE MANUAL

3.4.2 Refuelling

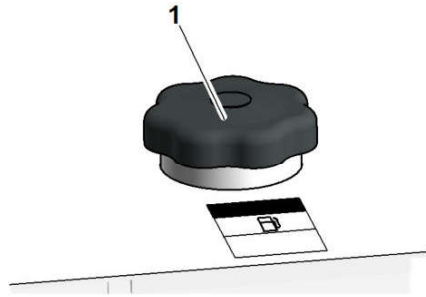

Fig. 569: Fuel tank

1 Tank lid



DANGER

Explosion of highly flammable fuel!
Danger to life.

- ▶ Avoid naked flames.
- ▶ Do not smoke.



Note

Sulphur content of fuel affects change interval of engine oil and oil filter.

- ▶ Adhere to sulphur content of fuel and change intervals of engine oil. (For more information see: [Difficulty factors](#), page 294)

If sulphur content of fuel is not known:

- ▶ Determine sulphur content with oil analysis set.

3.4.3 Refuelling with electric refuelling pump (option)

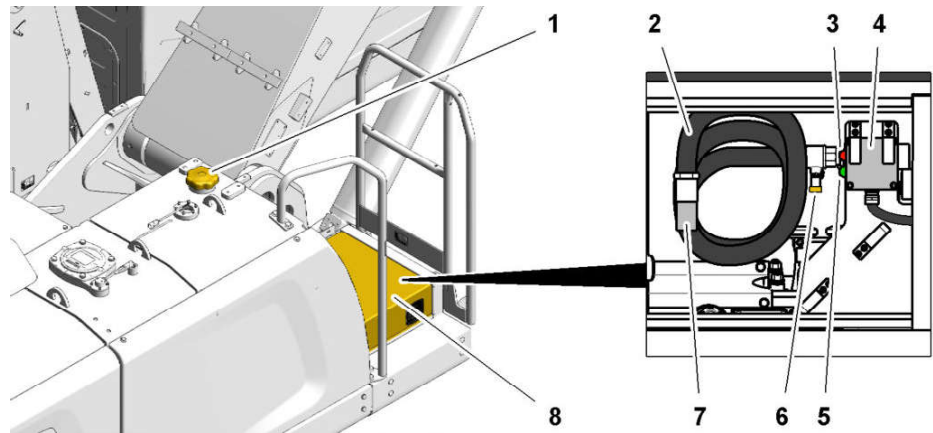









Fig. 570: Electric refuelling pump

- | | |
|--|---------------------------------------|
| 1 Tank lid | 5 Switching on refuelling pump button |
| 2 Suction hose | 6 Stop cock |
| 3 Switching off refuelling pump button | 7 Protective cap |
| 4 Remote control | 8 Hatch |

Operating mode			Application
Key	Status of LEDs	Mode	
	 ○ ○	S (SENSITIVE)	For especially precise work or lifting loads.
	○  ○	E (ECO)	For particularly economical and environmentally friendly work.
	○ ○ 	P (POWER)	For high transfer loading performance and heavy-duty applications.
	  	P+ (POWER PLUS)	For maximum load handling performance and heavy-duty applications.

Tab. 47: Operating modes

Operating mode S, E and P

Selecting operating mode with *MODE* key



- ▶ Press *MODE* key until required operating mode is active.
 - ▷ Control selects speed step for selected operating mode.
 - ▷ Operating mode appears on the display.
 - ▷ LEDs in *MODE* key display selected operating mode.

Selecting operating mode with engine speed controller

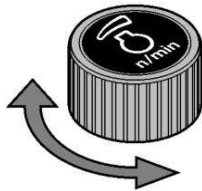

- ▶ Turn engine speed controller to right or left.
 - ▷ Control selects operating mode for selected speed step.
 - ▷ Operating mode appears on the display.
 - ▷ LEDs in *MODE* key display selected operating mode.

Operating mode P+

Operating mode P+ corresponds to speed step 10+. Operating mode P+ can exclusively be selected with engine speed controller.

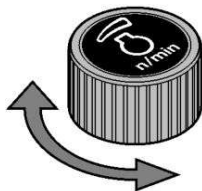





- ▶ Select operating mode P+: Turn engine speed controller to right.
 - ▷ Operating mode appears on the display.
 - ▷ LEDs in *MODE* key display selected operating mode.
- ▶ Exit operating mode P: Press *MODE* key.
or
Turn engine speed controller to left.

Engine speed and operating mode after starting machine

After starting the machine speed step 1 is preset.

In *Mode* key LEDs for the most recently activated operating mode flash.

Oscillating axle switch and service brake		Angle of rotation of uppercarriage	Effect on oscillating axle	Symbol on the display
Locked		All angles	Oscillating axle is locked, irrespective of the position of uppercarriage and service brake.	
Automatic system active and service brake closed	A	$\alpha < 15^\circ$	Oscillating axle is locked by oscillating axle support automatic.	
		$\alpha > 15^\circ$	Oscillating axle is locked by angle-controlled oscillating axle locking.	
Automatic system active and service brake open	A	$\alpha < 15^\circ$	Oscillating axle is unlocked.	-
		$\alpha > 15^\circ$	Oscillating axle is locked by angle-controlled oscillating axle locking.	

Tab. 56: Locking and unlocking oscillating axle according to angle of rotation

- ▶ Set operating mode according to driving situation. (For more information see: [3.6.3 Travelling at operating location, page 230](#)) (For more information see: [3.6.4 Travelling with load at operating location, page 231](#))

or

- ▶ Set operating mode according to working situation. (For more information see: [Putting machine with wheeled undercarriage with two axles in working position, page 229](#))

3.4.22 Supporting machine

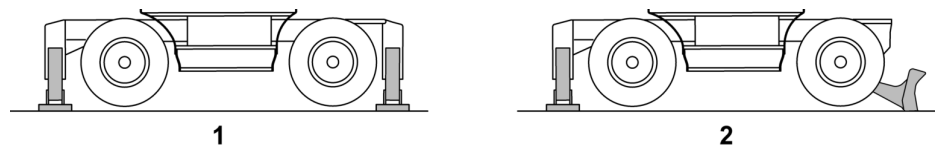

Fig. 637: Support variants

1 Outrigger support

2 Outrigger support and blade support



DANGER

Machine tipping over!
Danger to life.

- ▶ Make sure that ground is sufficiently stable.
- ▶ Make sure that support is fully in contact with solid, non-slip and level ground.
- ▶ Make sure that support is not fully extended.
- ▶ Make sure that wheels do not have ground contact.

3.4.27 Hoist cylinder pressure warning device (option)

Hoist cylinder pressure warning device fulfils following tasks:

- Warns operator of lowering of working attachment.
- Protects against damage from excessive hydraulic oil pressure.



DANGER

Unexpected machine movement!
Danger to life.

- ▶ Make sure there are no persons in working area of machine.



If *hoist cylinder pressure warning device* status symbol appears on the display and warning sound sounds:

- ▶ Reduce reach.
- ▶ Reduce load.

3.4.28 Lowering boom actively (option)



Note

Different machine configuration!

- ▶ Adhere to control description sticker.

If boom is not lowered through its curb weight:

- ▶ Stop attachment movements.
 - ▶ Press *active boom lowering* key.
- or**

Press button on joystick.

- ▷ *Lowering boom actively* status symbol appears on the display.



- ▷ Boom is lowered hydraulically.

3.4.29 Selecting the working tool



The machine can move working tools with various pressure settings and flow settings. The settings for working tools are listed in the *Tool Control* menu.

NOTICE



Incorrect settings!
Damage to the working tool.

- ▶ Make sure that the correct working tool is selected in the *Tool Control* menu.

- ▶ Select the working tool in the *Tool Control* menu.

Key	Meaning
	Stick cylinder shut-off is switched off.
	It is possible to set new shut-off points without restrictions.
	It is possible to move the stick without restrictions.
	Button is black. Teaching in shut-off point function is not available.

Tab. 67: Keys

Status symbol	Meaning
	Shortly before the shut-off point is reached the speed of the stick movements is automatically reduced.
	When a shut-off point is reached, the stick movement stops.
	When a shut-off point is reached, it is exclusively possible to move the stick to the other shut-off point.
	Stick cylinder shut-off is bypassed. It is possible to move the stick without restrictions.

Tab. 68: Status symbols

**DANGER**

Unexpected settings!
Danger to life.

- ▶ Inform all operators of machine about changes.
- ▶ Set shut-off points again after every working tool change.

Switching on stick cylinder shut-off

- ▶ Press *function settings* menu button.
- ▶ Press *stick cylinder shut-off* menu button.
- ▶ Press *stick cylinder shut-off* button 1.
- ▶ Press confirmation button.
 - ▷ *Stick cylinder shut-off* button lights up green:

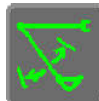
**Switching off stick cylinder shut-off**

- ▶ Press *function settings* menu button.
- ▶ Press *stick cylinder shut-off* menu button.
- ▶ Press *stick cylinder shut-off* button 1.
- ▶ Press confirmation button.
 - ▷ *Stick cylinder shut-off* button lights up white:



- ▶ Turn key to right into enabled position for authorisation.
- ▶ Press *height limitation* button.
- ▶ Press confirmation button.
 - ▷ *Height limitation* button lights up white:



- ▶ Turn key to left for authorisation.

Switching on height limitation

Make sure the following precondition is met:

- Settings for height limitation are enabled.
- ▶ Press *height limitation* button.
- ▶ Press confirmation button.
 - ▷ *Height limitation* button lights up green:



Switching off height limitation

Make sure the following precondition is met:

- Settings for height limitation are enabled.
- ▶ Press *height limitation* button.
- ▶ Press confirmation button.
 - ▷ *Height limitation* button lights up white:



Locking settings for height limitation



Note

After height limitation is locked, switched-on load moment limitation is locked.

- ▶ Make sure that load moment limitation is switched off.



Note

After height limitation is locked, switched-on slew limitation is locked.

- ▶ Make sure that slew limitation is switched off.



Note

After height limitation is locked, switched-on virtual wall is locked.

- ▶ Make sure that virtual wall is switched off.

A supervisor is authorised to lock following settings for the operator:

- Switch off height limitation.

- ▶ Press confirmation button.
 - ▷ *Depth limitation* button lights up white:



- ▶ Turn key to left for authorisation.

Switching on depth limitation

Make sure the following precondition is met:

- Settings for depth limitation are enabled.
- ▶ Press *depth limitation* button.
- ▶ Press confirmation button.
 - ▷ *Depth limitation* button lights up green:



Switching off depth limitation

Make sure the following precondition is met:

- Settings for depth limitation are enabled.
- ▶ Press *depth limitation* button.
- ▶ Press confirmation button.
 - ▷ *Depth limitation* button lights up white:



Locking settings for depth limitation



Note

After depth limitation is locked, switched-on load moment limitation is locked.

- ▶ Make sure that load moment limitation is switched off.



Note

After depth limitation is locked, settings for switched-on slew limitation are locked.

- ▶ Make sure that slew limitation is switched off.

A supervisor is authorised to lock following settings for the operator:

- Switch off depth limitation.
- Change maximum working depth.

Make sure the following precondition is met:

- Supervisor is present with authorisation key.
- ▶ Turn key to right into enabled position for authorisation.
- ▶ Press *depth limitation* button.
- ▶ Press confirmation button.



- ▶ Turn key to left for authorisation.

Switching on load moment limitation

If activated, load moment limitation is switched on when machine is started again. The signal lamp lights up.



DANGER

Machine tipping over!
Danger to life.

- ▶ Make sure that oscillating axle is locked.

Make sure the following preconditions are met:

- Load moment limitation is enabled.

Switching on load moment limitation using the display

- ▶ Press *load moment limitation* button 5.
- ▶ Press confirmation button.
 - ▷ LEDs in *load moment limitation* key on control unit A light up.
 - ▷ *Load moment limitation* button lights up green:

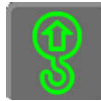

- ▷ Warning buzzer sounds briefly.
- ▷ Signal lamp lights up.

Switching on load moment limitation using control unit A



- ▶ Press *load moment limitation* key on control unit A.
- ▶ Press confirmation button.
 - ▷ LEDs in *load moment limitation* key on control unit A light up.
 - ▷ *Load moment limitation* button lights up green:

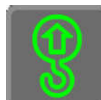

- ▷ Warning buzzer sounds briefly.
- ▷ Signal lamp lights up.

Switching off load moment limitation

Make sure the following precondition is met:

- Load moment limitation is enabled.

Switching off load moment limitation using display

- ▶ Press *load moment limitation* button 5.
- ▶ Press confirmation button.
 - ▷ LEDs in *load moment limitation* key on control unit A go out.

3.6.6 Handling loads

Handling loads



DANGER

Machine tipping over!
Danger to life.

- ▶ Make sure there are no persons in hazard zone.
- ▶ Make sure that ground has sufficient load-bearing capacity.
- ▶ Carry out all movements steadily.
- ▶ Draw working attachment in close to machine and move load close to the ground.



WARNING

Incorrect handling of grapple!
Injuries.

- ▶ Make sure that grapple and load do not swing close to operator's cab.
- ▶ Prevent grapple and load from swinging: Move joystick carefully and slowly.

- ▶ Adhere to load lift chart.
 - ▶ Carefully take up load.
 - ▶ Carefully swivel load over unloading point.
 - ▶ Put down load.
- or

Empty grapple.

Travelling with load

- ▶ Observe instructions about travelling.
- ▶ Align uppercarriage parallel to undercarriage.

3.6.7 Loading transport vehicle



DANGER

Falling load!
Danger to life.

- ▶ Make sure there are no persons in danger zone.
- ▶ Make sure that there are no persons in transport vehicle.
- ▶ Do not slew working attachment over operator's cab of transport vehicle.



- ▶ Lower working attachment.

If machine is equipped with wheeled undercarriage:

- ▶ Press *parking brake key*.

- ▶ Shut off diesel engine.
- ▶ Depressurise hydraulic system (For more information see: [5.10.1 Depressurising hydraulic system, page 342](#)).
- ▶ Move folding console up.

If machine is equipped with energy recuperation cylinder and block type ball valves on hoist cylinders:

- ▶ Close block type ball valves on hoist cylinders.
- ▶ Lock all doors and flaps and remove key.
- ▶ Fold in mirrors.
- ▶ Protect exhaust treatment system from water penetration.

3.9.4 Tying down machine

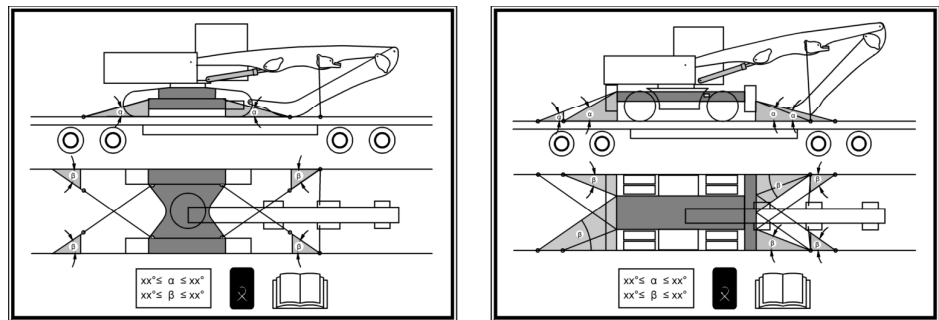

Fig. 834: Signs (example) in operator's cab

Make sure the following preconditions are met:

- Slip-resistant mats as per EN 12195-1 with a friction coefficient μ above 0.4 are designed for low-loaders.
- Lashing chains ensure lashing force as per EN 12195-3.

Maximum total weight of machine	Lashing force of lashing chain as per EN 12185-3
Up to 20 t	5000 daN
Up to 30 t	8000 daN
Up to 55 t	13400 daN
Up to 80 t	20000 daN
Over 80 t	32000 daN

Tab. 77: Lashing force of lashing chain as per EN 12185-3

4 Malfunctions

Machine reports machines through following warnings:

- Warning symbols on the display
- Messages on the display
- Warning sounds in the operator's cab

Rectify malfunction:





- Identify meaning of warning.
- Identify effects and property of malfunction.
- Rectify cause of malfunction.

Contact Liebherr customer service:

- Specify machine type.
- Specify serial number.
- Specify year of manufacture.
- When work is performed on the machine:
Make sure that the work is performed exclusively by trained staff.

4.1 Service code tables

4.1.1 Warning symbols

Symbol	Meaning	Effect, characteristic	Remedy
	Battery voltage is too high. Alternator is defective.	Electrical system is damaged.	Shut off diesel engine. Contact Liebherr customer service.
	Battery voltage is too low. Alternator is defective. Battery is defective.	Functionality is restricted.	
	Hydraulic oil level is too low. Hydraulic system leaks, oil loss.	Hydraulic system is damaged. Hydraulic output is reduced automatically.	Shut off diesel engine. Fill with hydraulic oil. If symbol is still displayed: Contact Liebherr customer service.
	Prewarning: Hydraulic oil temperature is high.	Hydraulic system is damaged. Hydraulic output is reduced automatically.	Shut off diesel engine. Check hydraulic oil cooler for contamination. Clean if necessary. If symbol is still displayed: Contact Liebherr customer service.
	Hydraulic oil temperature is too high. Hydraulic oil cooler is contaminated. Fan drive of hydraulic oil cooler is defective.		

LHB/12219536/01/2020-06-z7/en

Malfunction / error	Cause	Remedy
Smoke development: Exhaust gas is blue.	Oil level is too high.	Correct oil level.
	Engine oil is entering the combustion chamber.	Contact Liebherr customer service.
	Compressor-side seal on the exhaust turbocharger is defective.	Contact Liebherr customer service.
	Crankcase ventilation is defective.	Contact Liebherr customer service.
Diesel engine is knocking.	Combustion process is malfunctioning.	Contact Liebherr customer service.
Diesel engine is pinging.	Valve clearance is excessive.	Contact Liebherr customer service.
	Injection nozzles are damaged or contaminated by carbon deposits.	Contact Liebherr customer service.
	There is bearing damage.	Contact Liebherr customer service.
	Piston rings are worn or broken.	Contact Liebherr customer service.
Unusual noises or noise emissions can be heard from the exhaust system.	Exhaust system has a leak.	Contact Liebherr customer service.
Diesel engine performance too low (underperformance).	Fill level in diesel exhaust fluid tank is too low.	Fill with diesel exhaust fluid.

4.2.2 Hydraulic system

Malfunction / error	Cause	Remedy
Unusual noises or noise emissions can be heard. Hydraulic pumps draw in air.	Stop valve on hydraulic tank is closed. Hydraulic oil level is too low.	Shut off diesel engine or electric motor immediately. Check stop valve and fill level.
Machine movements are too slow.	Selected speed step too low.	Select higher speed step or different operating mode.
Power modes do not achieve required performance.	Control is defective.	Contact Liebherr customer service.
Hydraulic oil temperature is too high.	Radiator is contaminated.	Clean radiator.
	Fan drive is defective.	Shut off diesel engine or electric motor. Contact Liebherr customer service.
Hydraulic oil level is too low.	Hydraulic system is leaking and losing oil.	Contact Liebherr customer service.
No function assigned to control elements.	Servo control is switched off. Folding console is up.	Switch on servo control. Move folding console down.
	Control is defective.	Contact Liebherr customer service.

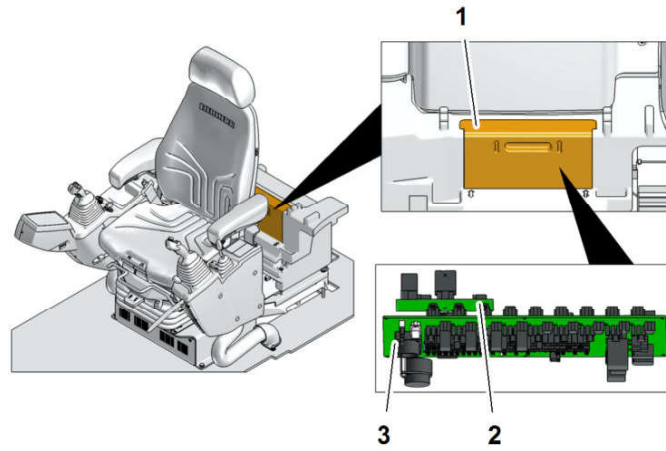

Fig. 918: Operator's platform fuses and relays

- | | | | |
|---|---------------------------------------|---|-------------------------|
| 1 | Cover | 3 | Main circuit board A161 |
| 2 | Additional printed circuit board A166 | | |

Customer:..... Machine type:..... Serial no.:..... Operating hours:..... Date:.....

Maintenance / inspection after service hours						Tasks to be performed					
On handover	All 8-10 h	All 50 h	All 500 h	All 1000 h	All 2000 h	Other intervals	Additional labelling	By maintenance staff	By authorised specialist staff	Confirm tasks	See page
								■ Once-only activity ● Repeat interval † If necessary ✱ Annually before the winter Additional labelling ††† Assistance required ‡ Have this task carried out exclusively by a certified electrician	□ Once-only activity ○ Repeat interval ✧ If necessary		
Brake system											
			○	○	○			Service brake and parking brake: Check function and effect.			
			○	○	○			Brake system: Check tightness.			
Electrical system											
			○	○	○			Check lighting of machine.			
			○	○	○			Batteries: Check acid density and acid level in the battery cells.			
			○	○	○			Batteries: Check and clean wire terminals and terminal posts.			
			○	○	○			Batteries: Check condition and correct installation of degassing hoses.			
Transmission											
			○	○	○			Transmission: Check oil level and tightness.			
			□	○	○			Transmission: Change oil.			
					○			Check function of parking brake.			
Axles											
			○	○	○			Axles: Check oil levels.			
			□	○	○			If driving makes up less than 30 % of the overall operating hours: Axles: Change oil.			
			○	○	○			If driving makes up more than 30 % of the overall operating hours: Axles: Change oil.			
		●	○	○	○			Lubricate axles (every week or every month, depending on the application).			351
						✧		Check wheel bearing and adjust if necessary (once after 100 operating hours, at least once a year).			
						○	✧	If installed: Check crown wheel kit (at least once a year).			
							✧	Multi-disc brake: Check wear. (at least once a year)			
			○	○	○		†	Tyres: Check tyre pressure.			352
			○	○	○		†	Check tightening torque of the wheel nuts (when the machine is new, each time a wheel is changed or the wheel nuts are loosened, and once after 50, 100 and 250 operating hours).			354
Working attachment											
	●	●	●	○	○			Lubricate working tool (follow manufacturer's instructions if working tool is not from Liebherr).			355
		●	●	○	○			Check pin bearings for wear.			355

LHB/122 19536/01/2020-08-z7/1en

5.3.4 Engine oils

Liebherr recommendation for stage IV / Tier 4f and stage V diesel engines

Description
Liebherr Motoroil 5W-30
Liebherr Motoroil 5W-30 low ash ²⁸⁾

Tab. 97: Liebherr recommendation

Other approved engine oils²⁹⁾

Description
Liebherr Motoroil 10W-40
Liebherr Motoroil 10W-40 low ash ²⁸⁾

Tab. 98: Other approved engine oils

Minimum quality requirements

Specification
LH-00-ENG3A LA ²⁸⁾
ACEA E6, ACEA E9, API CJ-4

Tab. 99: Minimum quality requirements

If engine oils from a third party manufacturer are used, information on change intervals must be obtained from respective manufacturer or supplier.

Liebherr recommendation for other emission stages

Diesel engine power	Performance category
To 129 KW	Power band I as per Regulation ECE-R.96 (stage 3A, TIER III, CHINA III equivalent)
From 130 KW	Power band H as per Regulation ECE-R.96 (stage 3A, TIER III, CHINA III equivalent)

Tab. 100: Liebherr recommendation for other emission stages

Description
Liebherr Motoroil 10W-40

Tab. 101: Liebherr recommendation

²⁸⁾ For machines with diesel particulate filter use low ash engine oil.

²⁹⁾ Adhere to change interval.

5.4 Access points for maintenance work

5.4.1 Access points on uppercarriage

General overview

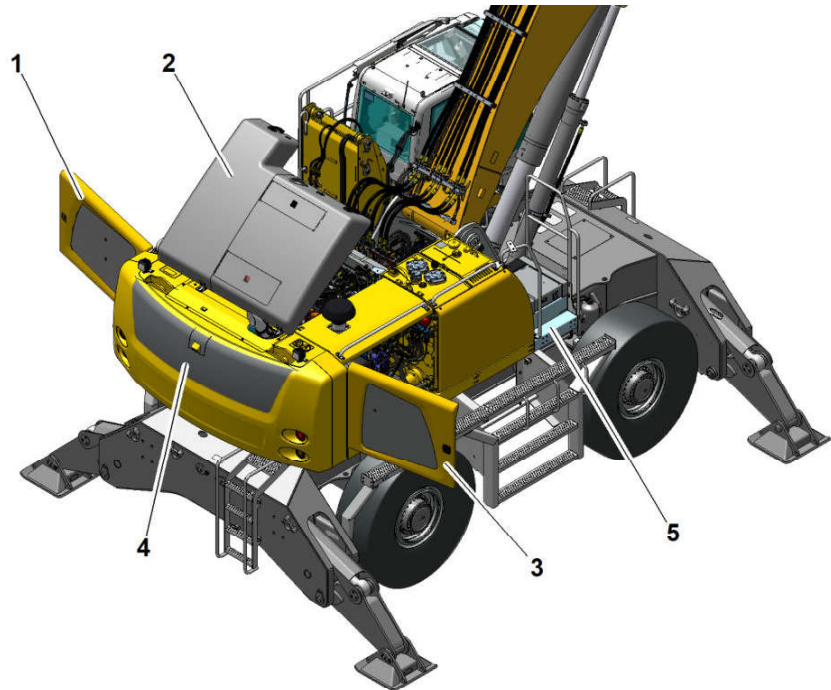

Fig. 930: Access points on uppercarriage

No.	Access point	Access to
1	Left side door	Battery main switch, batteries, fuse box, electric cabinet, radiator, condenser
2	Engine bonnet	Diesel engine, coolant container, fuel pre-filter, fuel fine filter, oil filter
3	Right side door	Hydraulic pumps, servo control unit, air filter
4	Cover plate	Exhaust muffler, diesel particulate filter, SCR module
5	Cab access	Fuel tank, diesel exhaust fluid tank, cab access, hydraulic tank, grease container, engine bonnet

Tab. 128: Access points on uppercarriage

5.6.4 Cleaning fan and radiator

**DANGER**

Explosion of highly flammable gases!
Danger to life.

- ▶ Make sure that degassing hoses are laid correctly.
- ▶ Do not clean battery area with compressed air.
- ▶ Avoid naked flames.
- ▶ Do not smoke.

**WARNING**

Hot parts!
Burns.

- ▶ Make sure that diesel engine has cooled down before starting work.

**WARNING**

Moving parts!
Injuries.

- ▶ Make sure that all parts have stopped moving before starting work.
- ▶ Shut off diesel engine.
- ▶ Clean radiator fins and fan wheel with compressed air.
- ▶ Blow from the inside of the machine to the outside.

5.8 Drive group

5.8.1 Diesel engine: Bringing into maintenance position

- ▶ Make sure diesel engine is standing horizontally.
- ▶ Shut off diesel engine.
- ▶ Let diesel engine cool down.
- ▶ Switch off battery main switch.
- ▶ Observe diverging instructions in description of the work steps.

5.8.2 Diesel engine: Checking oil level

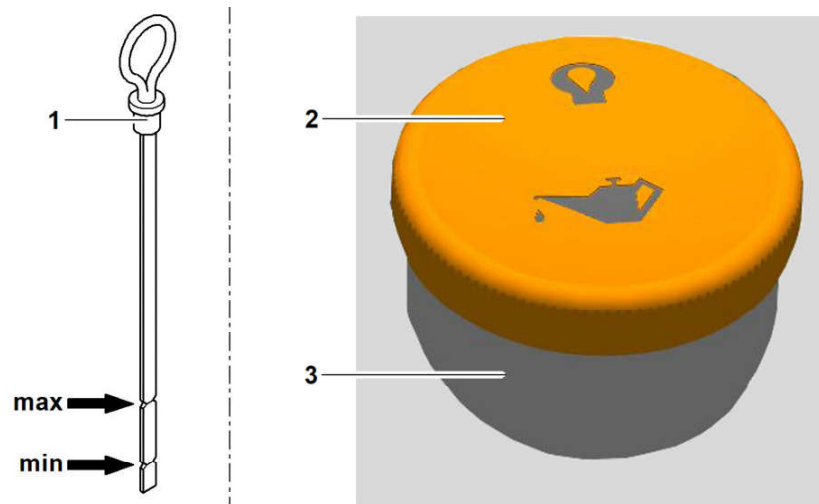

Fig. 944: Diesel engine: Checking oil level

- | | |
|---|------------------------|
| <p>1 Dipstick</p> <p>2 Oil fill cover</p> | <p>3 Oil fill pipe</p> |
|---|------------------------|



WARNING

Hot diesel engine and hot engine oil!
Burns.

- ▶ Let diesel engine cool down.
- ▶ Put on protective gloves.
- ▶ Avoid skin contact with hot diesel engine.
- ▶ Avoid skin contact with hot engine oil.

Make sure the following preconditions are met:

- Machine is horizontal.
- ▶ Shut off diesel engine.
- ▶ Wait 1 min until oil has collected in the oil pan.
- ▶ Pull out dipstick 1.

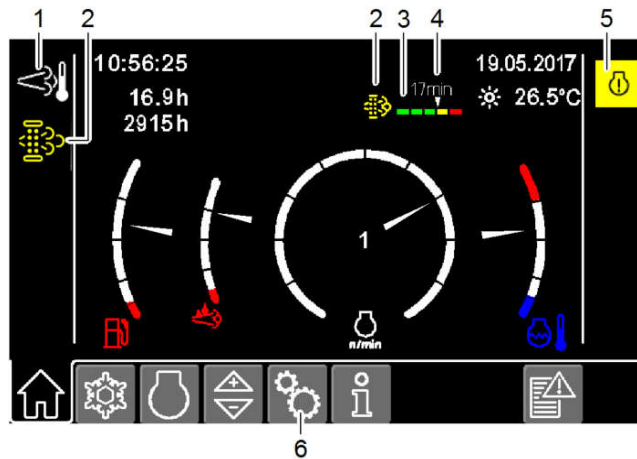

Fig. 951: Start page menu

- | | | | |
|---|--|---|---|
| 1 | Increased exhaust temperature status symbol | 4 | Remaining filter regeneration time |
| 2 | Diesel particulate filter contaminated status symbol | 5 | Prewarning: Control error of diesel engine warning symbol |
| 3 | Contamination level of diesel particulate filter | 6 | Function settings menu |

Contamination level of diesel particulate filter

NOTICE

Contaminated diesel particulate filter!
Damage to diesel engine.

- ▶ Shut off diesel engine.
- ▶ Have diesel particulate filter checked by Liebherr customer service.

The bar chart display on the display shows the contamination level of the diesel particulate filter in five stages. The pointer above the bar chart display indicates the degree of contamination of the diesel particulate filter.

	Stage 1	Stage 2	Stage 3	Stage 4	Stage 5	Stage 5
Stage shown on the display						
Activation of filter regeneration	—	—	—	Manual	Manual	Manually by Liebherr customer service
Deactivating or cancelling filter regeneration	—	—	—	Deactivating or cancelling possible	Cancelling possible	Cancelling possible

Tab. 137: Contamination level of diesel particulate filter

LHB/12219536/01/2020-06-z7/1en

- Diesel engine or electric motor is shut off.

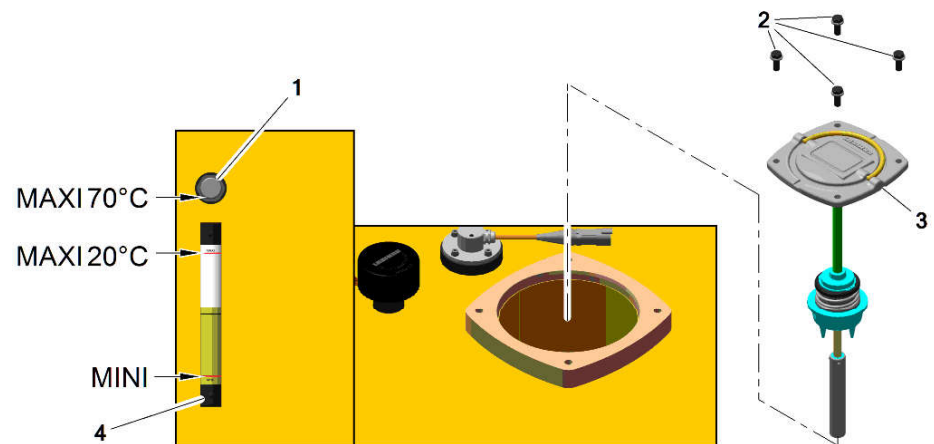

Fig. 983: Hydraulic tank

- | | | | |
|---|-----------------|---|---------------------|
| 1 | Oil sight glass | 3 | Return filter cover |
| 2 | Hex head screw | 4 | Oil sight glass |

- ▶ Check hydraulic oil temperature shown on the display.
- ▶ Make sure that hydraulic oil temperature is at 20 ± 5 °C.
- ▶ Extend hoist cylinders, stick cylinders, bucket cylinders, adjustable boom cylinders and support cylinders as far as possible.
- ▶ Check hydraulic oil level on oil sight glass 4.

If hydraulic oil level is below **MINI** mark:

- ▶ Fill with hydraulic oil. (For more information see: [Filling with hydraulic oil, page 343](#))
- ▶ Retract hoist cylinders, stick cylinders, bucket cylinders, adjustable boom cylinders and support cylinders as far as possible.
- ▶ Check hydraulic oil level on oil sight glass 4.

If hydraulic oil level is above **MAXI** mark:

- ▶ Drain hydraulic oil. (For more information see: [Draining hydraulic oil, page 344](#))

When the machine has reached operating temperature 70 °C:

- ▶ Retract hoist cylinders, stick cylinders, bucket cylinders, adjustable boom cylinders and support cylinders as far as possible.
- ▶ Check hydraulic oil level on oil sight glass 1.

If hydraulic oil level is above bottom edge of oil sight glass 1:

- ▶ Drain hydraulic oil. (For more information see: [Draining hydraulic oil, page 344](#))

Filling with hydraulic oil

NOTICE

Incorrect mixture of hydraulic oils!
Damage to hydraulic system.

- ▶ Do not mix hydraulic oils.

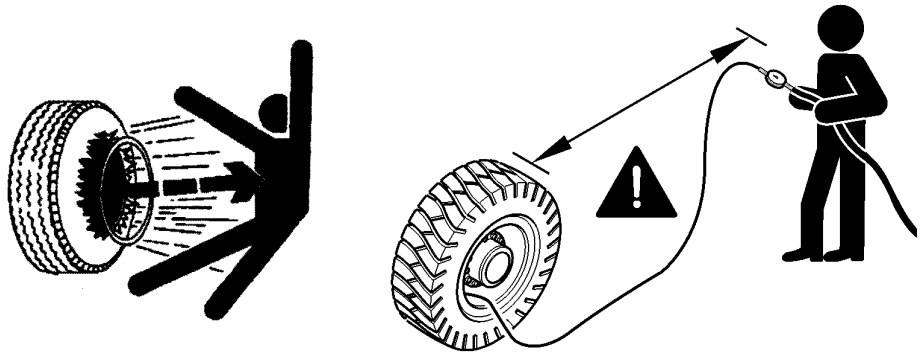

Fig. 992: Maintain safety distance



DANGER

Bursting tyre!
Death.

- ▶ Never pump up tyres that have gone flat.
- ▶ Use a sufficiently long tyre inflation hose with self-locking inflation valve.
- ▶ Stand sideways to the tyre and away from the danger zone.

Tyre pressure affects the operating behaviour of the machine.

Manufacturer	Type	Size	Air pressure
Bridgestone	VJT	23.5–25	6.50 bar
Bridgestone	VKT	20.5–25	6.50 bar
Bridgestone	VLT	20.5–25	6.50 bar
Bridgestone	VMT	20.5–25	6.50 bar
Bridgestone	VUT	20.5–25	6.50 bar
Goodyear	Hi Stab	20.5R25 RL-4K	7.00 bar
Goodyear	Hi Stab	20.5R25 RL-5K	7.00 bar
Michelin	XHA	20.5–25	5.00 bar
Michelin	XKA	20.5–25	8.00 bar

Tab. 143: Tyre pressure table

- ▶ See table for specified value.
- ▶ Connect measuring instrument
- ▶ Check tyre pressure.
- ▶ Correct tyre pressure if necessary.

NOTICE

Unsuitable gear oil!
Damage to gearbox.

- ▶ Exclusively use oil in approved quality.
-

- ▶ Remove protective cap **1** on oil tank **2**.
- ▶ Unlock cover with key.
- ▶ Open cover.
- ▶ Make sure that oil has prescribed viscosity.
- ▶ Fill oil tank **2** with prescribed oil until **MAX 3** marking is reached.
- ▶ Check oil level after 5 minutes.

If oil level is below **MAX 3** mark:

- ▶ Fill with oil.

If oil level remains unchanged:

- ▶ Screw cover onto oil tank **2**.
- ▶ Lock cover with key.
- ▶ Put protective cap **1** on oil tank **2**.

CLICK HERE TO **DOWNLOAD** THE COMPLETE MANUAL

- Thank you very much for reading the preview of the manual.
- You can download the complete manual from: www.heydownloads.com by clicking the link below



- Please note: If there is no response to CLICKING the link, please download this PDF first and then click on it.

CLICK HERE TO **DOWNLOAD** THE COMPLETE MANUAL