

en

Operator's manual

Wheel loader

L 586-461 (USA / CAN)

From serial number 33596

Document ID

	ORIGINAL OPERATOR'S MANUAL
Order number:	11652808
Issued:	01-2015
Version:	07
Author:	LBH / Technical Documentation Department

Product ID

Manufacturer:	Liebherr-Werk Bischofshofen GmbH
Type:	L 586 (USA / CAN)
Type no.:	461
From Serial no.:	33596

Conformity:



Contact

Address:	Liebherr-Werk Bischofshofen GmbH Dr. Hans Liebherr-Straße 4 A – 5500 Bischofshofen
-----------------	--

CLICK HERE TO **DOWNLOAD** THE COMPLETE MANUAL

- Thank you very much for reading the preview of the manual.
- You can download the complete manual from: www.heydownloads.com by clicking the link below



- Please note: If there is no response to CLICKING the link, please download this PDF first and then click on it.

CLICK HERE TO **DOWNLOAD** THE COMPLETE MANUAL

Contents

1	Product description	19
1.1	Technical description	19
1.1.1	Overview of the complete machine	19
1.2	Technical data	21
1.2.1	Information on vibrations	21
1.2.2	Sound emission	22
1.2.3	Engine	22
1.2.4	Electrical system	22
1.2.5	Travel drive	23
1.2.6	Axles	23
1.2.7	Braking	24
1.2.8	Steering	24
1.2.9	Working hydraulics	25
1.2.10	Working attachment	25
1.2.11	Driver's cab	25
1.2.12	Heating, air conditioning	26
1.2.13	Air conditioning	26
1.2.14	Diesel particle filter	26
1.2.15	Refuelling pump	26
1.2.16	Towing device	27
1.2.17	Ballast	27
1.2.18	Tyres	28
1.2.19	Snow chains or guard chains	30
1.2.20	Tyres with foam	30
1.2.21	Complete machine with bucket (Z kinematics)	30
1.2.22	Attachment - light material bucket	32
1.2.23	Attachment - forklift	33

LBH/11652808/07/01-2015/en

1.2 Technical data

1.2.1 Information on vibrations

Hand, arm and whole-body vibrations

The driver's seat installed in the machine by the manufacturer complies with ISO 7096:2000, EM3 for wheel loaders. If the seat is replaced, the new seat must also comply with this standard.

Hand/arm vibrations

When the machine is correctly operated, the weighted (frequency-evaluated) effective value for hand/arm vibrations as per ISO 5349-1:2001 is less than 2.5 m/s².

Whole-body vibrations

When the machine is correctly operated, weighted (frequency-evaluated) effective values for certain example applications of the machine can be seen in the tables listed below. These values are based on the information in the technical report ISO/TR 25398:2006 "Earth-moving machinery - Guidelines for assessment of exposure to whole-body vibration of ride-on machines - Use of harmonized data measured by international institutes, organizations and manufacturers". The measuring method corresponds to ISO 2631-1:1997. The listed effective values for typical machines are given with standard deviations. These deviations are classified according to light, normal and heavy-duty operating conditions. The operator must classify the operating conditions according to the terrain, site conditions, site organisation, material, machine equipment, mode of operation and expertise of the driver.

Because the stated values are individual effective values for certain common applications, it is only possible to approximately assess the driver's exposure to vibrations. Therefore, in order to precisely assess the driver's exposure to vibrations during an 8-hour working day, use the Liebherr brochure on whole-body vibrations and the special software. Both of these are available from Liebherr dealers or with the documentation CD (Liebherr Parts) supplied with each new machine.

(For more information see: [2.4.19 Protection against vibrations, page 61](#))

Machine type	Typical working cycles	Weighted effective value in m/s ² under light, normal and heavy-duty operating conditions ^{A)}								
		x axis			y axis			z axis		
		Light	Normal	Heavy	Light	Normal	Heavy	Light	Normal	Heavy
Wheel loader	Load & Carry	0.44	0.60	0.76	0.44	0.58	0.72	0.38	0.52	0.66
	Transfer	0.31	0.54	0.78	0.40	0.65	0.90	0.32	0.49	0.66
	V mode	0.50	0.71	0.91	0.37	0.60	0.83	0.40	0.54	0.68
	Mining	0.57	0.91	1.24	0.47	0.69	0.91	0.34	0.81	1.28

Tab. 1: Whole-body vibrations

LBH/11652808/07/01-2015/en

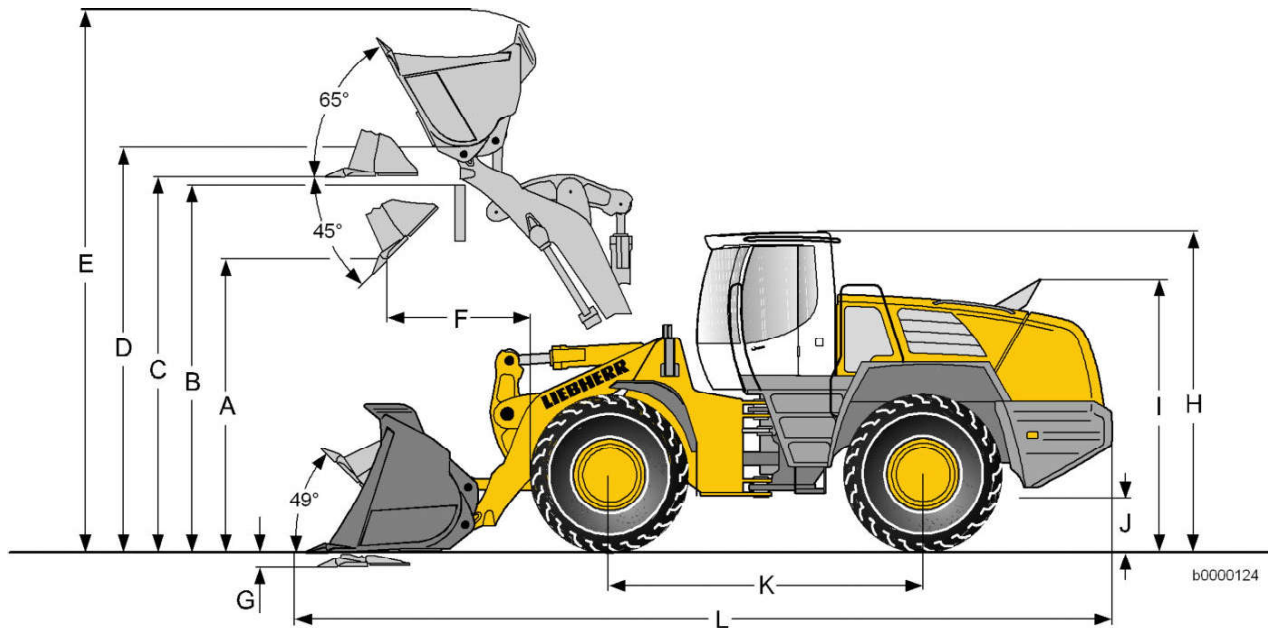

Fig. 20: Dimensions

Designation		Unit	Rating					
	Hydraulic quick-change device		No	No	No	No	No	No
	Attachment		STD ^{B)}	HL ^{C)}	STD ^{B)}	HL ^{C)}	STD ^{B)}	HL ^{C)}
	Bucket type		^{D)}	^{D)}	^{E)}	^{E)}	^{E)}	^{E)}
	Cutting tool		DZ ^{F)}	DZ ^{F)}	Z ^{G)}	Z ^{G)}	Z ^{G)}	Z ^{G)}
	Lift arm length	mm	3150	3450	3150	3450	3150	3450
	Bucket capacity as per ISO 7546 ^{A)}	m ³	5.5	5.5	5.5	5.5	6.0	6.0
	Bucket width	mm	3400	3400	3400	3400	3400	3400
	Specific material weight	t/m ³	1.8	1.6	1.8	1.6	1.6	1.4
A	Dump height at maximum lifting height and 45° tilt-out angle	mm	3330	3745	3310	3725	3260	3670
B	Dump height	mm	4150	4500	4150	4500	4150	4500
C	Maximum bucket base height	mm	4300	4770	4330	4750	4330	4750
D	Maximum bucket pivot point height	mm	4660	5080	4640	5060	4640	5060
E	Maximum bucket top height	mm	6400	6800	6500	6950	6530	6980
F	Reach at maximum lifting height and 45° tilt-out angle	mm	1370	1370	1385	1370	1430	1410
G	Digging depth	mm	140	140	100	100	100	100
H	Height above cab	mm	3760	3760	3740	3740	3740	3740
I	Height above exhaust	mm	3330	3330	3310	3310	3310	3310
J	Ground clearance	mm	595	595	575	575	575	575
K	Wheelbase	mm	3900	3900	3900	3900	3900	3900
L	Overall length	mm	9950	10300	9930	10250	9960	10280

LBH/11652808/07/01-2015/en

Meaning: **Only open the cap of the filler neck when the engine has cooled down - the coolant temperature should be in the bottom third of the segment field in the display.**

Engine standstill sign

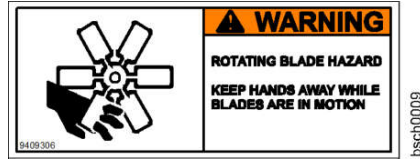

Fig. 34

Warns of the risk of accidents, possibly resulting in severe injuries.

Meaning: **Only open when the engine is shut down**

Danger of burns sign



Fig. 35

The sign is attached to the top of the rear engine cover.

It warns the driver or mechanic not to touch the silencer, its connections or the exhaust pipe while the engine compartment hood is open.

Meaning: **Do not touch the hot air filter or the exhaust pipe.**

Voltage sign



Fig. 36

Refers to the battery main switch.

Meaning: **The electrical system is energised when the battery main switch is turned on.**

7. Wear safe working clothes when working on the machine.
Do not wear rings, wristwatches, ties, scarves, unbuttoned jackets, loose clothing or similar garments, as they can become caught in the machinery and cause injury.
Certain tasks require safety goggles, safety boots, hard hats, gloves, reflective vests, ear protection etc.
8. Ask the site manager about any special safety regulations in force on the site.
9. Do not hold onto the steering column, the control panel or the control levers when getting on or off the machine.
You might inadvertently trigger movements which could lead to accidents.
10. Never jump down from the machine. Use the steps, ladders and platforms provided for getting on and off.
11. Keep all handles, steps, rails, gangways, platforms and ladders free from oil, grease, mud snow and ice. This reduces the risk of slipping, tripping up or falling.
12. Familiarise yourself with the emergency exit through the right cab door and/or the rear window.
13. Unless there are other instructions, perform maintenance and repair work as follows:

Procedure:
 - Park the machine on firm, level ground and lower the working attachment to the ground.
 - Move all control levers to neutral.
 - Shut down the engine and take out the ignition key.
14. Before starting any work on the hydraulic circuit, you must also press the working hydraulics lockout button and actuate all pilot control units (joystick and pedals) in both directions in order to reduce the control pressure and accumulated pressure in the operating circuits. You must then reduce the internal tank pressure.
15. Lock the working hydraulics to prevent accidental actuation before leaving the driver's cab.
Lock the working hydraulics in accordance with the instructions in the **operating manual**.
16. Secure all loose parts of the machine.
17. Never start up a machine without first making a thorough tour of inspection and checking if any warning signs are missing or illegible.
18. Observe all signs with warnings or safety instructions.
19. Special safety apparatus must be fitted to the machine for certain applications. If this is the case, only work with this apparatus fitted and in working order.
20. Do not make any modifications, extensions or conversions to the machine with possible safety implications without the approval of the supplier. This also applies to installing and adjusting safety apparatus and valves, as well as to welding load-bearing components.
21. Avoid standing near the engine while it is running. People who have a pace-maker must not stand next to the diesel engine while it is running (minimum distance 50 cm).
22. Do not touch live components of the solenoid controlled unit pumps on their electrical connections.

2.4.2 Instructions on preventing crushing injuries and burns

1. Do not work under the attachment if it is not resting on the ground or supported.
2. Do not use any ropes or chains which are damaged or which have insufficient load bearing capacity.
Wear protective gloves when handling wire ropes.

Preventing accidents

Depending on the job and the way the machine is operated, hazards can arise even when the protective apparatus is intact. Avoid all unsafe working practices.

The roll-over protection structure cannot guarantee safety if the maximum permitted total machine weight (see type plate) is exceeded.

The following modifications to the machine can lead to the maximum total weight being exceeded:

- Using attachments that are too heavy
- Changing the working attachment
- Attachments or modifications to the machine

Never use a machine whose cab protection system (ROPS, FOPS) has been damaged.

Damage to the cab can be caused by the following operations and events:

- Welding, cutting or drilling holes
- Attaching brackets
- Deformation after an accident
- Falling objects

Structural modifications and any kind of repairs are prohibited.

Preventing injuries

The cab roll-over protection system can only protect the driver if he is wearing a safety belt.

Any modifications to the interior of the cab, such as installing accessories, may not impair the driver's working space.

Objects carried in the cab may not project into the driver's working space. Loose objects must be stored securely.

2.4.18 Attachments and accessories

1. Attachments and accessories produced by third-party manufacturers or those which have not been generally approved by LIEBHERR for installation or for external fitting may not be installed or fitted on the machine without prior written consent from LIEBHERR.
2. The appropriate technical documentation should be made available to LIEBHERR for this purpose.
3. When adding or converting equipment or tyres, the stability of the machine must be tested and ensured in accordance with **EN 474**.
(For more information see: [1.2 Technical data, page 21](#))

2.4.19 Protection against vibrations

1. The vibrations to which mobile construction machines are subjected are mainly due to the way they are used.

The following parameters in particular have a great effect:

- Terrain conditions: bumps and potholes.
- Operating methods: speed, steering, braking, use of the controls while driving and while working.

2. The amount of vibration depends to a large extent on the machine operator, because he determines the speed, gear ratio, working methods and distance covered.

Opening the hinged window

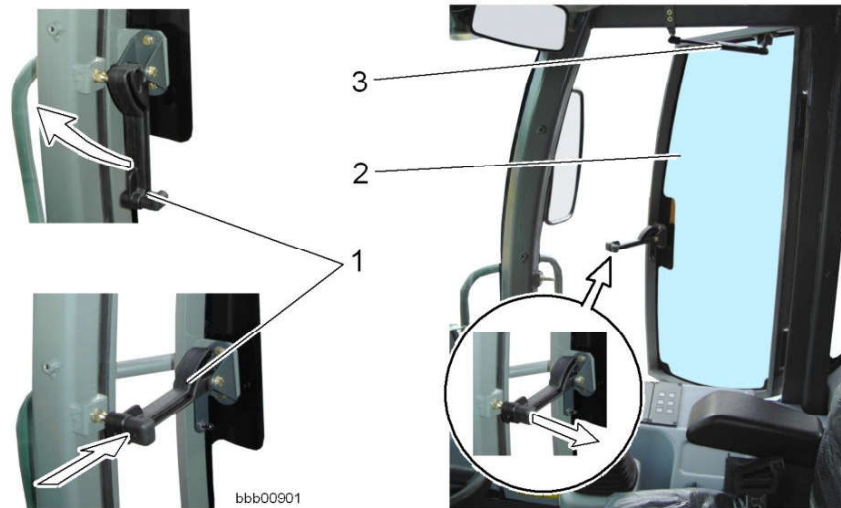

Fig. 67: Opening and closing the hinged window

- | | |
|-----------------------|---------------------|
| 1 Window opener lever | 3 Gas-filled spring |
| 2 Hinged window | |

► Push up the lever **1** until it locks into place.

To further open the hinged window:

- Release the lever **1** from the retaining pin and let it go.
 ▷ The gas-filled spring **3** opens the window.

Closing the hinged window

- Guide the lever **1** (see: fig. 67, page 71) over the retainer and push the hinged window down until it is closed.

3.2.5 Emergency exit



b0000780

The right window (hinged window) is designed as an emergency exit and should be used as such in an emergency situation.

An emergency hammer is installed in the driver's cab for breaking the windows. Before starting the machine, make sure there is an emergency hammer in the driver's cab.



Note

If it is not possible to safely leave the cab through the entry or hinged window in an emergency situation:

- Break the hinged window or rear window with the emergency hammer and leave the driver's cab!

Adjusting the back rest inclination

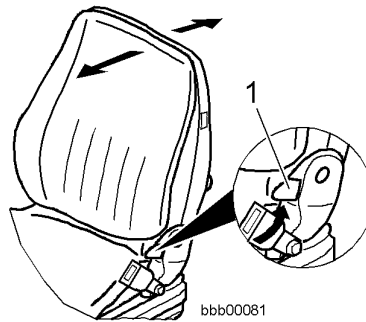

Fig. 87: Adjusting the back rest inclination

1 Lever for back rest inclination adjustment

- ▶ Raise the lever 1.
- ▶ Move the back rest to the angle required.
- ▶ Let go of the lever 1.

Activating and deactivating horizontal suspension on the driver's seat

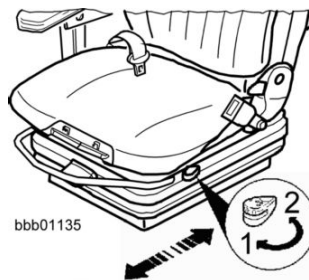

Fig. 88: Activating and deactivating horizontal suspension on the driver's seat

1 Horizontal suspension deactivated **2** Horizontal suspension activated

Under certain conditions you can increase comfort by activating the horizontal suspension.

Advantage: the driver's seat can better absorb shocks in the direction of travel.

- ▶ Position **1** = off
- ▶ Position **2** = on

3.2.9 Seat belt

Safety aspects of the seat belt

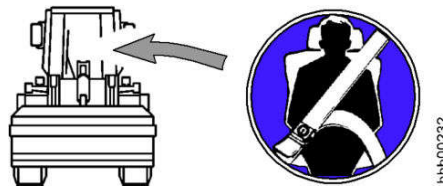

Fig. 105: Always wear a seat belt

The driver's cab is equipped with roll-over protection (**ROPS**).

The ROPS roll-over protection system can only protect the driver if the seat belt has been fastened.

This section describes the safety considerations for wearing the seat belt.



WARNING

There is a risk of injuries if the seat belt is not fastened.

If the machine tips or rolls over, the driver could suffer fatal injuries if he is not wearing a safety belt.

If the machine is braked or stops abruptly, the driver may suffer severe injuries if he is not wearing a safety belt.

- ▶ It is essential that you fasten your seat belt before starting up the machine.

To guarantee your safety,

- ▶ Regularly check the condition, function and fastening of the seat belt.
- ▶ Immediately replace damaged parts.
- ▶ Do not twist the seat belt.

Fastening the seat belt

The seat belt is an automatic belt.

You do not need to adjust the belt length.

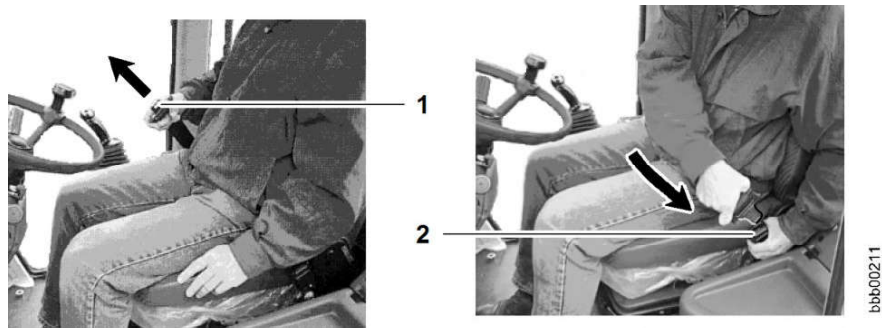

Fig. 106: Fastening the seat belt

1 Belt buckle

2 Snap lock

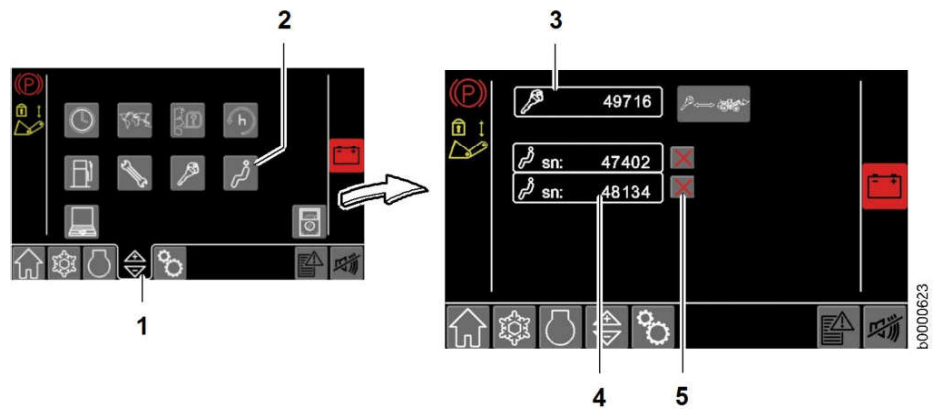

Fig. 119: Deleting the driver profile

- | | | | |
|---|----------------------------------|---|--|
| 1 | Settings switching button | 4 | Starting key with saved driver profile display |
| 2 | Driver identification button | 5 | Delete driver profile button |
| 3 | Master key serial number display | | |

► Press button 5.

- ▷ The driver profile for starting key 4 has been deleted.

Deleting the driver profile using the starting key:

Using the starting key, switch on the ignition and open the display screen using the switching buttons *Settings* and *Driver identification*.

The starting key can only delete its own driver profile.

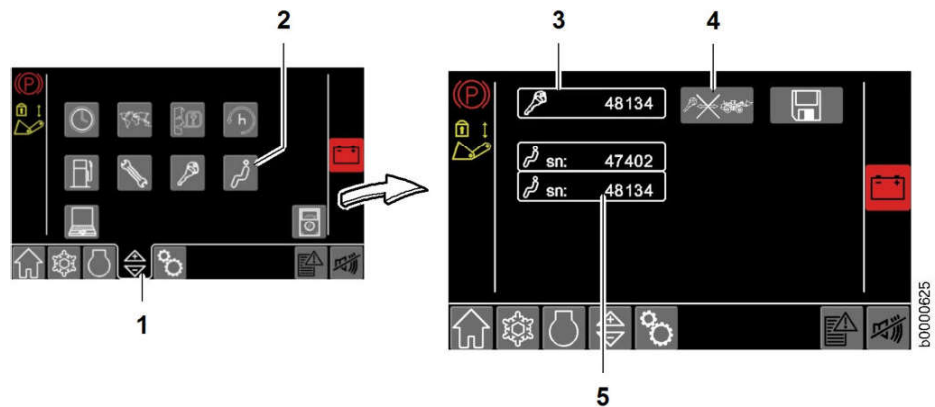

Fig. 120: Deleting the driver profile

- | | | | |
|---|--------------------------------------|---|--|
| 1 | Settings switching button | 4 | Delete driver profile button |
| 2 | Driver identification button | 5 | Starting key with saved driver profile display |
| 3 | Display - Starting key serial number | | |

► Press button 4.

- ▷ The driver profile for starting key 5 has been deleted.

3.2.15 Steering column switch

The steering column switch is mounted on the steering column.

- | | | | |
|----------|---------------------------------|-----------|---|
| 3 | <i>Remaining fuel indicator</i> | 11 | Options |
| 4 | Fuel consumption indicator | 12 | Coolant temperature |
| 5 | Clock, operating hour meter | 13 | <i>Disable continuous beep</i> button |
| 6 | Preselected travel range | 14 | Speed, speed unit |
| 7 | Service notification | 15 | Tractive force reduction |
| 8 | Current gear | 16 | Engine speed, engine overspeed warning symbol |

Main screen switching button



b0000175

For switching to the “main screen display”

Tank capacity



b0000163

- Fuel level in litres
- White - fuel level >0%
- Flashing red - fuel level <0%

Remaining fuel indicator

Can be enabled on request by Liebherr customer service.



b0000467

- Indicates the remaining fuel in the tank.

Fuel consumption indicator

Can be enabled on request by Liebherr customer service.



b0000164

- Displays *fuel consumption* in l/h (litres per operating hour)

Clock, operating hour meter



b0000165

- Current time
- Total operating hour meter
- Daily operating hour meter
- Egg timer symbol - is displayed when the engine is running

Preselected travel range



b0000166

- F1, F2, A1-2, A1-3, A2-3

Service notification



b0000181

Indicates each time a service is due

- The yellow service symbol appears when a prior-warning time of 100 operating hours is reached
- The red flashing service symbol appears when the following post-warning time of up to 100 operating hours is reached
- (For more information see: [Service management, page 120](#))

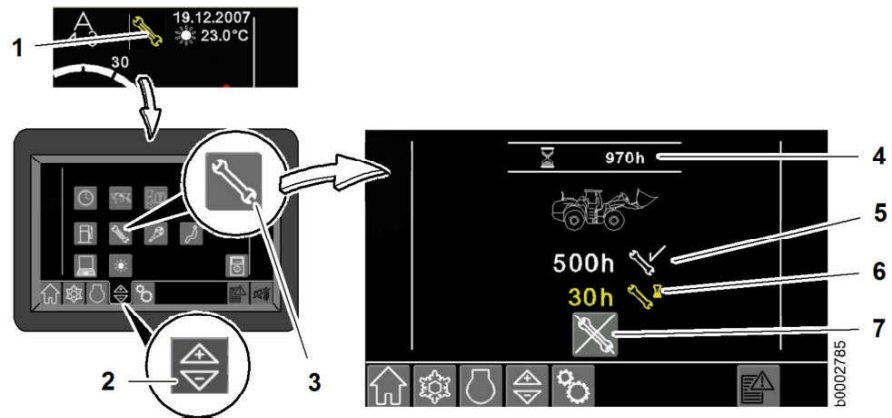

Fig. 188: Service management display

- | | | | |
|---|------------------------------------|---|---|
| 1 | Service notification "main screen" | 5 | Operating hours when service last confirmed |
| 2 | Settings switching button | 6 | Operating hours until next service |
| 3 | Service management | 7 | Disable service notification on the main screen |
| 4 | Machine operating hours | | |

- Each time a service is due, a service notification 1 is shown on the main screen of the display unit (*prior warning time of 100h = continuous yellow; post warning time of 100h = flashing red*).
- If the prior warning time until the next service is reached, the indicator 6 changes from white to yellow.
- If the post warning time until the next service is reached, the indicator 6 changes from yellow to red. A negative value shows that the service is already overdue.
- If an impending service is performed and confirmed by Liebherr customer service, the service notification 1 disappears.
- If a service is not performed and confirmed before the post warning time expires, the system switches over automatically to the next service and the service notification 1 on the main screen disappears. At the same time, a service code is saved to the memory of the on-board electronics.

To disable the "service notification" on the main screen:

- ▶ Press button 7.
 - ▷ Service notification 1 is disabled.
 - ▷ The service code is saved in the memory of the on-board electronics.
 - ▷ The symbol 1 only appears again when the next service is due.



Note

Disable the "service notification" on the main screen!
Disabling the "service notification" is not a service confirmation.

- ▶ Have Liebherr customer service perform the pending service.

Electronic immobilizer

This equipment is optional.

Press the *Settings* and *Electronic immobilizer* switching buttons to open the display screen.

Working hydraulics lockout



bbb00550

Working hydraulics lockout button

Disables and enables the working hydraulics functions.

When you press the button for the first time:

- Function ON
- The working hydraulics lockout is activated
- All three LEDs on the button light up

When you press the button a second time:

- Function OFF
- The working hydraulics lockout is deactivated
- All three LEDs on the button go out



Note

The setting remains stored after the ignition is switched off.

► This means the function is active when the ignition is switched on again.

The working hydraulics lockout remains active as long as the engine is not running.

You can temporarily deactivate the working hydraulics lockout by pressing the button.

Bucket return-to-dig

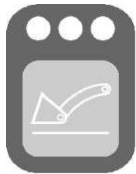

bbb00551

Bucket return-to-dig button

Switches the automatic bucket return-to-dig function on or off.

When you press the button for the first time:

- Function ON
- A solenoid on the pilot control device is activated
- All three LEDs on the button light up

When you press the button a second time:

- Function OFF
- A solenoid on the pilot control device is deactivated
- All three LEDs on the button go out

The LIEBHERR control lever is held in the bucket tilt-in position by magnetic force.



Note

The setting remains stored after the ignition is switched off.

► This means the function is active when the ignition is switched on again.

Selecting a higher travel range

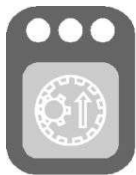

bbb00552

Travel range up button

Selects a higher travel range.

The selected travel range is indicated on the display unit.

When you press the button:

- The travel range is shifted up
- All three LEDs on the button briefly light up

Flashing beacon / visible back-up alarm

This equipment is optional.

Versions:

- Flashing beacon (single-position switch)
- Flashing beacon / visible back-up alarm (two-position switch)

Flashing beacon

Field colour - green

Switches the flashing beacon on or off.

The function can also be activated when the ignition key is in the 0 position or parking position.

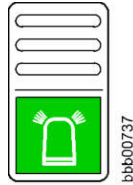

Flashing beacon / visible back-up alarm

Field colour - green

Switches the visible back-up alarm on or off.

Switch functions:

- Position I - flashing beacon (permanently on). The function can also be activated when the ignition key is in the 0 position or parking position.
- Position II - visible back-up alarm. (For more information see: [Visible back-up alarm, page 161](#))

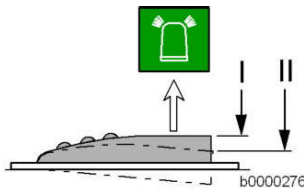

3.2.22 LIEBHERR control lever

This section describes the design and function of the LIEBHERR control lever.

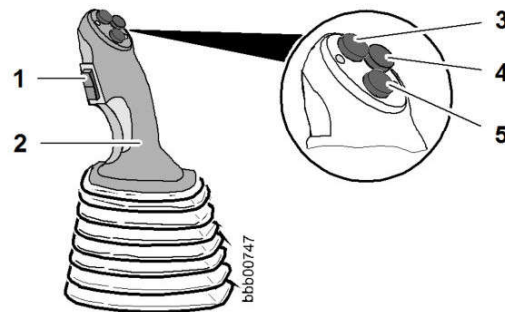

Fig. 241: Control lever

- | | | | |
|---|-------------------------|---|-----------------------------|
| 1 | Control lever | 4 | Additional equipment button |
| 2 | Travel direction switch | 5 | Comfort control button |
| 3 | Kick-down button | | |

Integrated controls:

- Lever with pilot control unit for controlling the working attachment.
- Switch 2 for changing travel direction between forward and reverse.
- Button 3 for "kick-down" shifting.
- Button 4 for operating:
 - an additional hydraulic function, such as the high dump bucket
 - or optional horn
 - or optional bucket return-to dig
- Button 5 for "comfort control", e.g. optional hydraulic quick-change device.

To switch on defrost mode:

- ▶ Press the button 1.
 - ▷ All three LEDs on the button light up.
 - ▷ Air conditioning is active.
 - ▷ The highest blower speed is active.
 - ▷ The front windscreen is defrosted.

To switch off defrost mode:

- ▶ Press the button 1 again.
 - ▷ All three LEDs on the button go out.
 - ▷ Heating, ventilation or air conditioning is activated, depending which was previously set.

Re-heat mode

This is only available if an air conditioning system is installed.

On cold, damp days, you can use the air-conditioning system to dehumidify the cab.

To dehumidify the cab air:

- ▶ Switch on the air conditioning system in addition to the heater. (For more information see: [Heater/air conditioning mode, page 114](#))
 - This stops the windows from misting up:
 - ▷ The damp air condenses on the evaporator.
 - ▷ It is then drained outside into the drip pan.

3.2.25 Rear window heater and mirror heater (optional)

This function is only available when the ignition is on.

Switching the rear window heater and mirror heater (optional) on and off

Fig. 257: Switching the rear window heater and mirror heater (optional) on and off

To switch on the rear window heater and mirror heater (optional)

- ▶ Press the button 1.
 - ▷ All three LEDs on the button light up.
 - ▷ The rear window heater and mirror heater (optional) is switched on.
 The function remains active after it is switched on:
 - ▷ Until the rear window heater and mirror heater (optional) is switched off manually
 - ▷ Or for a maximum 20 minutes (to protect the battery).

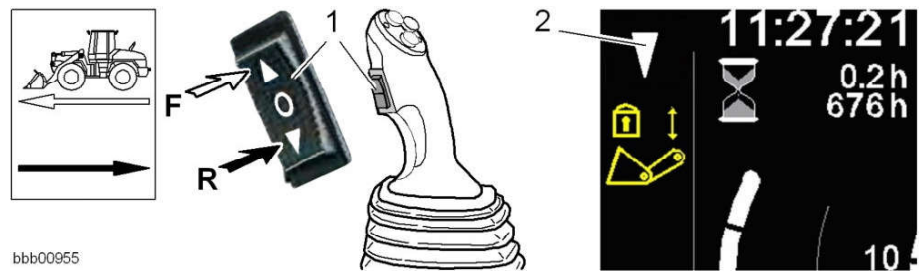

bbb00955

Fig. 272: Audible back-up alarm

- | | | | |
|---|---------------------------------------|---|----------------------------|
| 1 | Travel direction switch | F | = Forward travel direction |
| 2 | Reverse travel direction symbol field | R | = Reverse travel direction |



bpik0006

- ▶ Press the switch 1 for **R = REVERSE** travel direction.
 - ▷ The back-up alarm installed in the engine compartment emits an audible warning signal (intermittent tone).

Deactivating the back-up alarm

This equipment is optional.



WARNING

There is an increased risk of accidents if you deactivate the back-up alarm.

- ▶ Be especially careful when reversing.



b0000236

Fig. 274: Deactivating the back-up alarm

- | | |
|---|----------------------|
| 1 | Back-up alarm switch |
|---|----------------------|
- ▶ Press the switch 1.
 - ▷ The switch symbol lights up
 - ▷ No audible warning signal



Note

Reactivate the back-up alarm.

- ▶ Press the switch 1 (the switch symbol goes out).

Visible back-up alarm

Depending on the version, the machine is fitted with the following warning device(s):

- Two red warning lights
- Yellow flashing beacon on the rear
- Yellow flashing beacon on the driver's cab



Fig. 291: Ignition switch starting position

- ▶ Turn the ignition key to the starting position II and hold it in that position until the engine starts.
- ▶ **Do not hold the key in the starting position for more than 20 seconds at a time.**

If the engine does not start:

- ▶ Turn the ignition key back to the 0 position.

Troubleshooting

The engine will not start!

- ▶ Wait 60 seconds and try to start the engine again.

If the engine does not start after three attempts, find the cause and rectify it.

- ▶ [\(For more information see: 4 Malfunctions, page 253\)](#)
-

- ▶ Let go of the ignition key as soon as the engine starts running.
 - ▷ The ignition key automatically returns to the operating position.
 - ▶ **When the engine starts, the following symbol fields must go out:**
 - ▷ 1 Engine oil pressure ([see: fig. 289, page 170](#))
 - ▷ 2 Battery charge ([see: fig. 289, page 170](#))
 - ▷ 3 Brake accumulator pressure ([see: fig. 289, page 170](#))
-

Troubleshooting

The symbol fields do not go out?

- ▶ Switch off the engine and rectify the problem as described in the section "Malfunctions".
-

- ▶ Once the engine has started, decrease the engine speed to a medium speed.
- ▶ Run the engine for a short time to warm it up by operating the working attachment at a medium load.
- ▶ Then gradually increase to full load.

Starting precautions at cold temperatures



Fig. 292: Winter operation

The following precautions help you start the engine at cold temperatures.

CLICK HERE TO **DOWNLOAD** THE COMPLETE MANUAL

- Thank you very much for reading the preview of the manual.
- You can download the complete manual from: www.heydownloads.com by clicking the link below



- Please note: If there is no response to CLICKING the link, please download this PDF first and then click on it.

CLICK HERE TO **DOWNLOAD** THE COMPLETE MANUAL

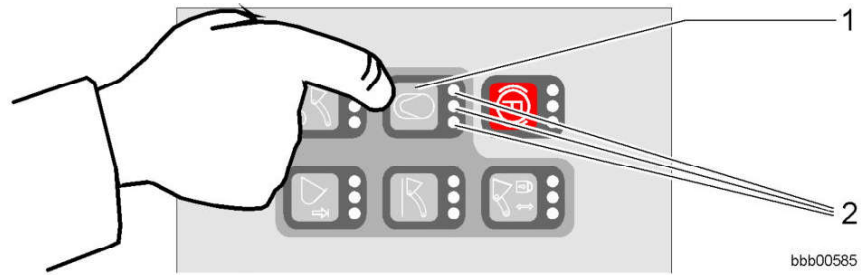
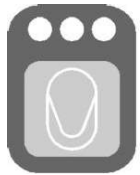

Fig. 314: Control unit

- 1 Ride control button
- 2 LEDs

Press the button 1 for ride control (LFD system) to prepare the function.



- ▶ Press the button 1 for ride control (LFD system).
 - ▷ All 3 LEDs on the pressed button flash.
 - ▷ The LFD system is now activated.
 - ▷ The LFD system automatically switches on when the machine speed is more than 10 km/h.

Reversing

The machine can be reversed in either travel direction and at any travel speed.

Shifting process when reversing

- When reversing in travel ranges A1-2 (automatic), A1-3 (automatic) or A2-3 (automatic) the machine does not shift back automatically to gear level G1.
- The system only shifts to gear level G1 when it is not possible to drive off in gear level G2.

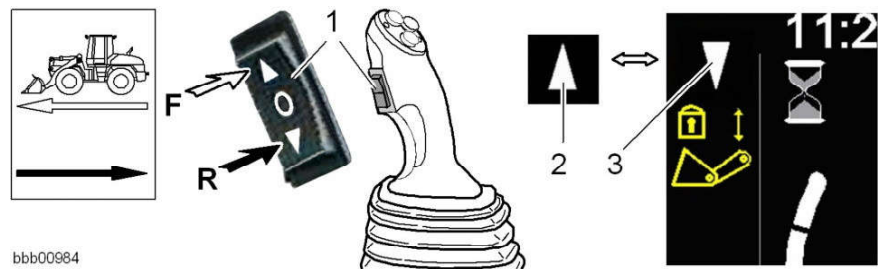

Fig. 316: Travel direction switch and display unit

- 1 Travel direction switch
- 2 "Forward" travel direction symbol field
- 3 "Reverse" travel direction symbol field

- ▶ To change the travel direction: Press the switch 1.
 - ▷ Depending on the switch position, the symbol field for forward travel 2 or for reverse travel 3 lights up.

LBH/11652808/07/01-2015/en

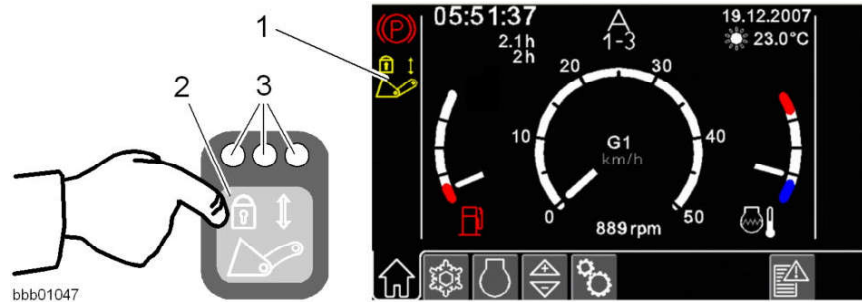

Fig. 337: Control unit

- 1 Working hydraulics lockout symbol field
- 2 Working hydraulics lockout button
- 3 LEDs

- ▶ Deactivate the working hydraulics lockout by pressing the button 2.
 - ▷ All three LEDs 3 on the pressed button go out.
 - ▷ The symbol field 1 for the working hydraulics lockout goes out.
 - ▷ The working hydraulics are now operational.
 - ▷ You can operate the working attachment.

Operating the lift cylinders

The lift cylinders raise and lower the lift arms.

Raising or lowering the lift arms

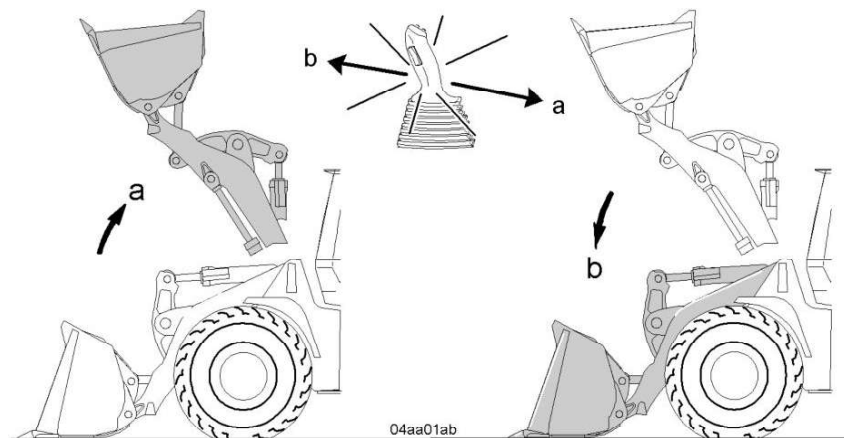

Fig. 338: Raising or lowering the lift arms

- ▶ Move the LH control lever in direction a.
 - ▷ The lift arms are raised.

There are two ways to lower the lift arms:

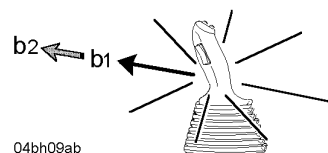

Fig. 339: LH control lever

LBH/11652808/07/01-2015/en

**Note**

After the exhaust counterpressure warning is activated, you must take action to reduce the counterpressure.

- ▶ If the evaluation of the measured data shows that no action was taken to reduce the counterpressure, the manufacturer's warranty becomes void.

Exhaust counterpressure warning: (Preliminary alarm) filter almost full

- ▶ Gradually increase the exhaust temperature (e.g. by operating at full load, avoiding prolonged idling times etc.).

If the exhaust counterpressure continues to fall below the set threshold value:

- The acoustic alarm is automatically deactivated.
- The display changes to operating mode.
- The machine can continue to be operated.

If this is not the case:

- ▶ The audible alarm can be deactivated by pressing the reset button **3**.
 - ▷ The message on the display **2** remains.

Exhaust counterpressure warning: Warning soot filter full

- ▶ The audible alarm can be deactivated by pressing the reset button **3**.
 - ▷ The message on the display **2** remains.
- ▶ Switch off the machine securely.
- ▶ Contact Liebherr customer service.

If the exhaust counterpressure continues to fall below the set threshold value:

- ▶ By pressing the reset button **3** (for about 3 seconds) the indicator in the display **2** changes to operating mode.
- ▶ Contact Liebherr customer service.

Exhaust counterpressure warning: Error! Break in the filter

- ▶ Switch off the machine securely.
- ▶ Contact Liebherr customer service.
 - ▷ If there are several malfunction messages these are shown on a rotating basis on the display **2**.

Exhaust counterpressure warning: Pressure sensor defective

- ▶ The audible alarm can be deactivated by pressing the reset button **3**. The message on the display **2** remains.
- ▶ Switch off the machine securely.
- ▶ Contact Liebherr customer service.

If the error is rectified:

- ▶ The audible alarm can be deactivated by pressing the reset button **3**.

Temperature sensor defective

- ▶ The audible alarm can be deactivated by pressing the reset button **3**. The message on the display **2** remains.
- ▶ Switch off the machine securely.

Dumping

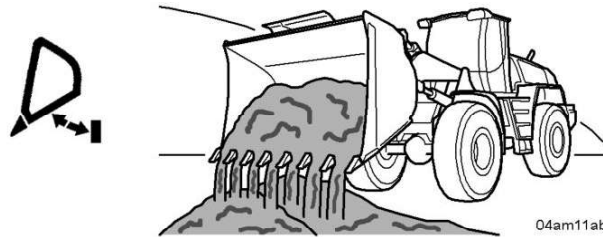

Fig. 370: Dumping

- ▶ Tip out the bucket.
To loosen material adhering to the bucket:
- ▶ Quickly tilt the bucket in and out, briefly jolting against the bucket arm stops.

3.4.5 Removing material from a slope or wall

Removing material from a slope

This is how to remove normal material such as sand or gravel.



Fig. 371: Removing bulk material 1

- ▶ Start at the foot of the slope and work upwards.

Removing material from a wall

This is how to remove unusually hard material such as rock.

- ▶ Remove the hydraulic lines and quick-release couplings from the installed working attachment.
- ▶ Seal the line couplings with a cap.
- ▶ Place the hydraulic lines in the hose retainer.

Activating the quick-change device

In order to unlock the working attachment, you must first activate the quick-change device.



WARNING

Beware of the working attachment dropping.

- ▶ Do not actuate the switch lever when the working attachment is raised.

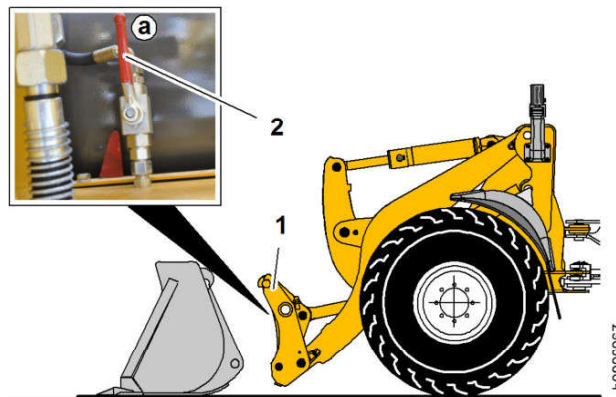

Fig. 391: Activating the quick-change device

- | | | | |
|---|---------------------|---|---|
| 1 | Quick-change device | a | Lever position when the <i>quick-change device</i> is activated |
| 2 | Switch lever | | |

- ▶ Pull the switch lever **2** out of the twist lock, turn it to position **a** and engage it in the twist lock again.
 - ▷ The function for unlocking the quick-change device is activated.

Unlocking and disconnecting the working attachment

Make sure that:

- The quick-change device is activated.
- All hydraulic lines and quick-release couplings are removed from the installed working attachment.

- ▶ Take the caps off the line couplings.
- ▶ Connect the hydraulic lines according to their function.

Note the following points when connecting:

- Clean the line couplings before connecting.
 - Do not connect the wrong ends of the hydraulic lines.
 - Lay the hydraulic lines so that they cannot become caught in the working attachment during operation.
 - Use the hose retainers provided when laying the lines.
- ▶ Check the hydraulic lines for leaks after connecting them.

3.5.3 Operating the quick-change device with comfort or button control

This equipment is optional.

The quick-change device is fitted on the front of the attachment holder and is used for changing the working attachment.

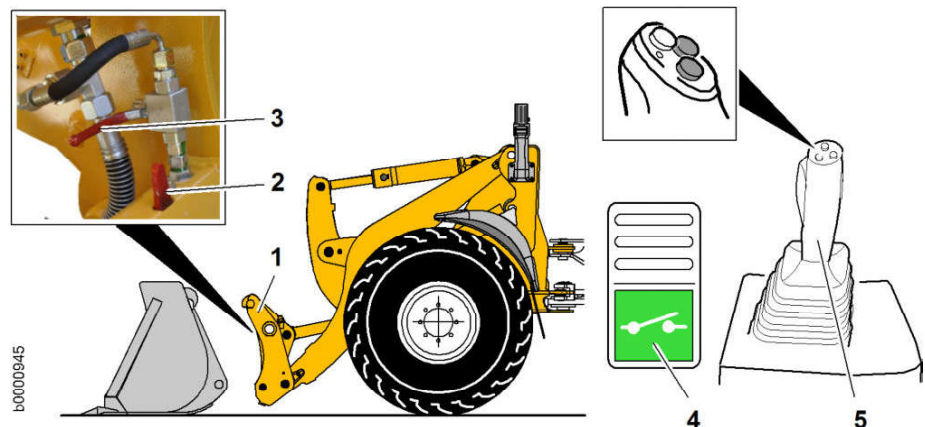

Fig. 404: Quick-change device

- | | | | |
|---|----------------------------------|---|------------------------|
| 1 | Quick-change device | 4 | Comfort control switch |
| 2 | Locking indicator | 5 | Control lever |
| 3 | Quick-change device switch lever | | |



Note

No equipment or attachments of other makes may be installed or attached to the machine without prior written consent from Liebherr.

- ▶ The appropriate technical documentation should be made available to Liebherr for this purpose.

Removing the working attachment

Carry out the following steps:

1. Depressurising the operating circuits²⁷⁾
2. Disconnecting the hydraulic lines²⁷⁾
3. Activating the quick-change device

²⁷⁾ If the working attachment has an independent hydraulic supply

**DANGER**

Beware of falling loads!
There is a risk of fatal injury.

- ▶ Align slinging gear vertically (maximum angle of incline = 10°).
- ▶ Do not stand under raised machinery.

- ▶ Fix the lifting tackle to the slinging and lifting points **a**, **b**, **c**, **d** on the machine.

In order to avoid damage, the slinging gear must not touch any other parts of the wheel loader when lifting:

- ▶ Carefully lift the machine and load it.

Transporting the machine by lorry or rail

Observe the safety regulations when transporting the machine. (For more information see: [2.4.9 Transporting the machine safely, page 55](#))



Fig. 415: Transporting the machine by lorry or rail

The inclination of the ramp **W** may not exceed 30°.

Make sure the following preconditions are met:

- Wedges are available.
- Suitable tensioning ropes or chains are available to lash the machine down.
- A ramp is available for driving the machine onto the loading area.

Driving onto the loading area

**WARNING**

There is a risk of injury to the person giving directions!

To give directions safely:

- ▶ Take up a position outside the danger area of the machine.
- ▶ Stay in view of the operator or keep in spoken contact.

Make sure there is someone to give the driver the necessary signals.

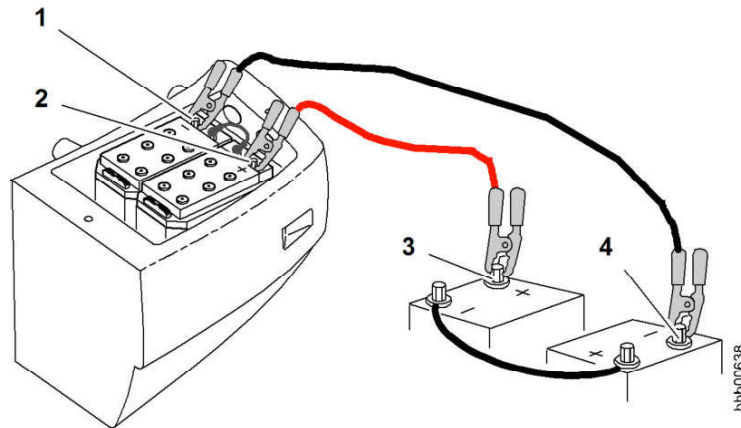

Fig. 431: Jump starting

- | | | | |
|---|---------------------------------------|---|---|
| 1 | Negative terminal of the flat battery | 3 | Positive terminal of the external battery |
| 2 | Positive terminal of the flat battery | 4 | Negative terminal of the external battery |

**Note**

Before attaching the jump lead, take the following precautions:

- ▶ Only use a jump lead with an appropriate cross-section.
- ▶ First connect one jump lead to the positive terminal 2 of the flat battery and then to the positive terminal 3 of the external battery.
- ▶ Connect the second jump lead first to the negative terminal 4 of the external battery and then to the negative terminal 1 of the flat battery.
- ▶ Start the engine.

To disconnect the external battery:

Excess voltage can be avoided by switching on major consumers such as headlights.

**Note**

Before disconnecting the jump leads:

- ▶ Make sure the engine is at the lower idling speed.
- ▶ First disconnect the jump lead from the negative terminal 1 of the flat battery and then from the negative terminal 4 on the external battery.
- ▶ Then remove the second jump lead first from the positive terminal 2 of the discharged battery and then from the positive terminal 3 of the external battery.

Servicecode	Effect	Cause	Remedy
M4008	No float position available	Float position: shorted at output	Check fuse F48 - contact LIEBHERR CUSTOMER SERVICE
M400A	Fan turns at full speed	Fan: shorted at output	Check fuse F48 - contact LIEBHERR CUSTOMER SERVICE
M400B	Fan turns at full speed	Fan: interruption at output	Check fuse F48 - contact LIEBHERR CUSTOMER SERVICE
M400C	Fan turns at full speed	Fan: fault current at output	Check fuse F48 - contact LIEBHERR CUSTOMER SERVICE
M400D	Fan turns at full speed	Fan: The measured return current at the output does not match the output current	Check fuse F48 - contact LIEBHERR CUSTOMER SERVICE
M400E	Warning buzzer does not work	Warning buzzer: shorted at output	Check fuse F48 - contact LIEBHERR CUSTOMER SERVICE
M4010	Possible gearbox damage, coupling damage during longer trips	Swivel angle restriction: shorted at output	Check fuse F48 - contact LIEBHERR CUSTOMER SERVICE
M4011	Possible gearbox damage, coupling damage during longer trips	Swivel angle restriction: interruption at output	Check fuse F48 - contact LIEBHERR CUSTOMER SERVICE
M4012	Automatic range A2-3 activated (1st gear disabled), kick-down not possible	Coupling 1: shorted at output	Check fuse F60 - contact LIEBHERR CUSTOMER SERVICE
M4013	Automatic range A2-3 activated (1st gear disabled), kick-down not possible	Coupling 1: interruption at output	Check fuse F60 - contact LIEBHERR CUSTOMER SERVICE
M4014	Fixed gear 1 is activated and variable displacement motor 1 is set to a wide angle to prevent overspeed	Coupling 2: shorted at output	Check fuse F60 - contact LIEBHERR CUSTOMER SERVICE
M4015	Fixed gear 1 is activated and variable displacement motor 1 is set to a wide angle to prevent overspeed	Coupling 2: interruption at output	Check fuse F60 - contact LIEBHERR CUSTOMER SERVICE
M4016	Continued driving is only possible in fixed gear 1 or 2 or automatic range A1-2	Coupling 3: shorted at output	Check fuse F60 - contact LIEBHERR CUSTOMER SERVICE
M4017	Continued driving only possible in fixed gear 1 or 2 or automatic range A1-2	Coupling 3: interruption at output	Check fuse F60 - contact LIEBHERR CUSTOMER SERVICE
M4018	Sudden shifting	Modulation: shorted at output	Check fuse F60 - contact LIEBHERR CUSTOMER SERVICE

Servicecode	Effect	Cause	Remedy
MA026	Calculation error - depends on the fault	Calculation error, output module 2, module has sent an internal error code.	Contact LIEBHERR CUSTOMER SERVICE
MA027	Calculation error - depends on the fault	Calculation error, output module 1, module has sent an internal error code.	Contact LIEBHERR CUSTOMER SERVICE
MA028	Calculation error - depends on the fault	Calculation error, input module 2, module has sent an internal error code.	Contact LIEBHERR CUSTOMER SERVICE
MA029	Calculation error - depends on the fault	Calculation error, input module 1, module has sent an internal error code.	Contact LIEBHERR CUSTOMER SERVICE
MA02A	Calculation error - depends on the fault	Master unit calculation error, module sent an internal error code	Contact LIEBHERR CUSTOMER SERVICE
MA02B	Calculation error - depends on the fault	CAN module calculation error	Check fuse F36 - contact LIEBHERR CUSTOMER SERVICE
MA02C	Calculation error - depends on the fault	General calculation error	Contact LIEBHERR CUSTOMER SERVICE
MA032		Master buffer battery defective or absent	Contact LIEBHERR CUSTOMER SERVICE
MA033		Low voltage in master buffer battery	Contact LIEBHERR CUSTOMER SERVICE
MA034		CAN: Option input module 4 timeout, hardware defective, error in CAN wiring	Contact LIEBHERR CUSTOMER SERVICE
M8500A281	Weighing system does not work	CAN bus: Weighing system timeout - hardware defective, error in the CAN wiring	Check fuse F28a - contact Liebherr customer service
M8500A282	Weighing system does not work	A23: Weighing module defective - hardware error	Contact Liebherr customer service
M8500A283	Weighing system does not work	A23: Pressure sensor failed - pressure sensor defective	Contact Liebherr customer service
M8500A2A9	Weighing device not working	Calibratable weighing device alibi memory is full	Contact Liebherr customer service
M8500A2B2	Weighing device not working	A24: Calibratable scale display not available	Check fuse F28a - contact Liebherr customer service

5 Maintenance

5.1 Maintenance and inspection schedule

The following abbreviations are used in this section:

- h = service hours

Various symbols (solid or empty circles, boxes and stars) are used to indicate the maintenance tasks, which fall into two main types.

	●	●				✦
		■				

bsym0039

The symbols have the following meanings:

Table with solid circle, box or star

- Responsibility for carrying out the maintenance work lies with the machine operator or his maintenance personnel.

This affects the maintenance intervals every 10 and 50 service hours (h) and non-scheduled intervals.

□		○	○	○	✦	
		□	○	○	250h	

bsym0040

The symbols have the following meanings:

Table with empty circle, box or star, or service hours (h)

- The maintenance and inspection work must be performed or supervised by authorised engineers from Liebherr or its authorised dealers.

This affects the maintenance interval: on delivery and every 500, 1000, 2000, 3000 service hours (h), and at unscheduled times.

A list of the spare parts needed for maintenance and inspection work is contained in the service package of the spare parts list.

Machines filled at the factory with environmentally harmless hydraulic fluids have a sign to that effect (NOTICE) attached to the driver's cab and hydraulic tank.

Procedure for later conversion

NOTICE

Beware of damaging the machine's hydraulic system. Mixing environmentally harmless hydraulic fluids with mineral oils produces a vigorous reaction that can damage the hydraulic system.

- ▶ Never mix environmentally harmless hydraulic fluid with mineral oil.
-
- ▶ If you intend to convert the machine to environmentally harmless hydraulic fluid, you **must** first consult Liebherr CUSTOMER SERVICE.
 - ▶ It is essential that you order the **instruction sheet** and the **conversion guidelines** from Liebherr and that you observe them.

5.3.3 Diesel fuels

Specification



06sy02ab

Diesel fuels must comply with the minimum requirements of the following specifications.

Specifications:

- DIN EN 590
- ASTM D 975-89a – 1D and 2D

Sulphur content in the diesel fuel

Diesel fuels with a maximum sulphur content of 0.5 % are recommended. Complicating factors should be considered for a sulphur content between 0.5% and 1%. A sulphur content of more than 1% is not permissible.

If the diesel engine is operated using E6 engine oil and a standard oil change interval (500 operating hours), diesel fuels with a sulphur content of more than 0.005% (50 mg/kg) may not be used.

Diesel fuel lubricity

According to the HFRR (60) test, the maximum diesel fuel lubricity must be 460 µm (lubricity-corrected wear scar diameter [1.4] at 60 °C).

Written confirmation must be provided by the fuel supplier.

The additives should be added by the supplier in its capacity as agent responsible for fuel quality. The addition of secondary lubricity additives by the customer is not recommended.



Note

- ▶ Obtain written confirmation from the supplier.
-

LS = limited slip additive:

- Not required for splitter boxes

If Liebherr oils cannot be purchased locally, oils that comply with the specifications must be used instead (after consultation with customer service).

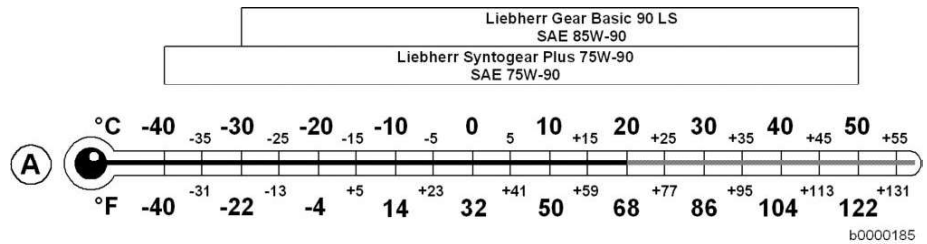

Fig. 448: Selection of the SAE class according to temperature

A Ambient temperature

The temperature ranges specified in the diagram are guidelines and can be briefly exceeded or fallen short of.

5.3.8 Lubricating oils for transmissions

Recommended lubricant	Specification
Liebherr Hydraulic Gear ATF	GM: Dexron II D ZF: TE-ML 03D, 04D, 11A, 14A, 17C

Tab. 36: Lubricating oil specifications

If Liebherr oils cannot be purchased locally, you must use oils according to the specifications instead (after consultation with customer service).

NOTICE

Oil quality

- Mixing various types of oil is not permitted.

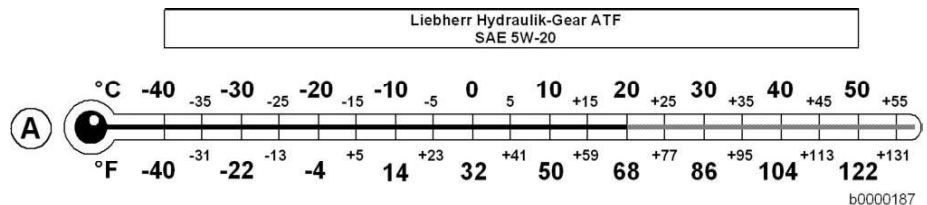

Fig. 449: Selection of the SAE class according to temperature

A Ambient temperature

The temperature ranges specified in the diagram are guidelines and can be briefly exceeded or fallen short of.

5.3.9 Lubricating oils for axles

Recommended lubricant	Specification
Liebherr Gear Basic 90 LS	API: GL-5

LBH/11652808/07/01-2015/en

5.5 Complete machine

5.5.1 Remove loose parts, dirt, ice and snow from the machine

Make sure that the machine is in maintenance position 1.



Note

To ensure safe machine transport and easy maintenance:
Clean the machine after everyday work and before starting maintenance tasks.

- ▶ Remove any loose parts, coarse dirt, mud, ice, snow etc.
- ▶ Be careful when cleaning the machine with a high-pressure cleaner.
 - ▷ (For more information see: [5.19 Cleaning the machine, page 361](#))

5.5.2 Checking the machine for external damage

Make sure that the machine is in maintenance position 1.

- ▶ Before starting the machine, check it for external damage.
- ▶ Repair any damage with safety implications immediately.

5.5.3 Making sure the bolted connections are tight

Make sure that:

- The machine is in maintenance position 2.
- The appropriate service doors, hatches and hoods are open.
- ▶ Check that all bolts and screws are tight.
- ▶ Tighten any loose screws or bolts with the required tightening torque.

5.5.4 Sealing leaks

Make sure that:

- The machine is in maintenance position 2.
- The appropriate service doors, hatches and hoods are open.
- ▶ Check the entire hydraulic system for leaks.
- ▶ Replace any damaged hydraulic seals.
- ▶ Tighten any loose hydraulic connections.
- ▶ (For more information see: [2.4.16 Safe maintenance of hydraulic hoses and hose lines, page 60](#))

5.5.5 Carry out corrosion protection on machines that work with salt and artificial fertilizers

This equipment is optional.

If you carry out corrosion protection:

- ▶ See the separate operator's manual "Using salt and artificial fertiliser".

Bleeding the fuel filter

Procedure



DANGER

There is a risk of fire and explosions.

- ▶ Do not smoke.
- ▶ Avoid naked flames.
- ▶ Only work with the engine switched off and cooled down.



bbb00615

Fig. 475: Bleeder screw on the head of the fuel prefilter



CAUTION

Beware of fuel spurting out.

- ▶ Wear safety glasses.
 - ▶ Unscrew the bleeder screw 1 on the filter top of the fuel prefilter by 2 to 3 turns.
 - ▶ Operate the hand pump 2.
- When fuel flows out of the bleeder screw without bubbles:
- ▶ Close the bleeder screw 1 with a tightening torque of 7^{+2} Nm .
 - ▶ Continue to operate the hand pump until you feel strong resistance.

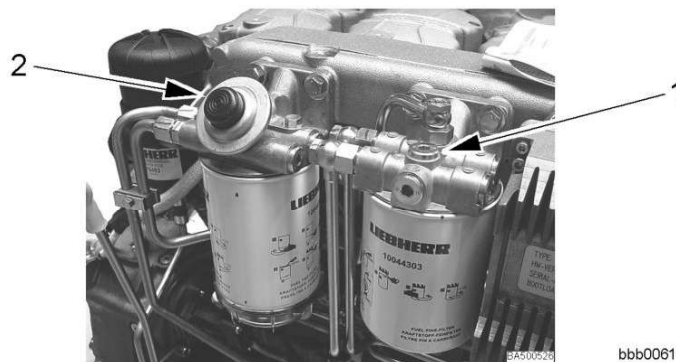

bbb00614

Fig. 476: Bleeder screw on the head of the fuel fine filter

- ▶ Unscrew the bleeder screw 1 on the filter top of the fuel fine filter by 2 to 3 turns.

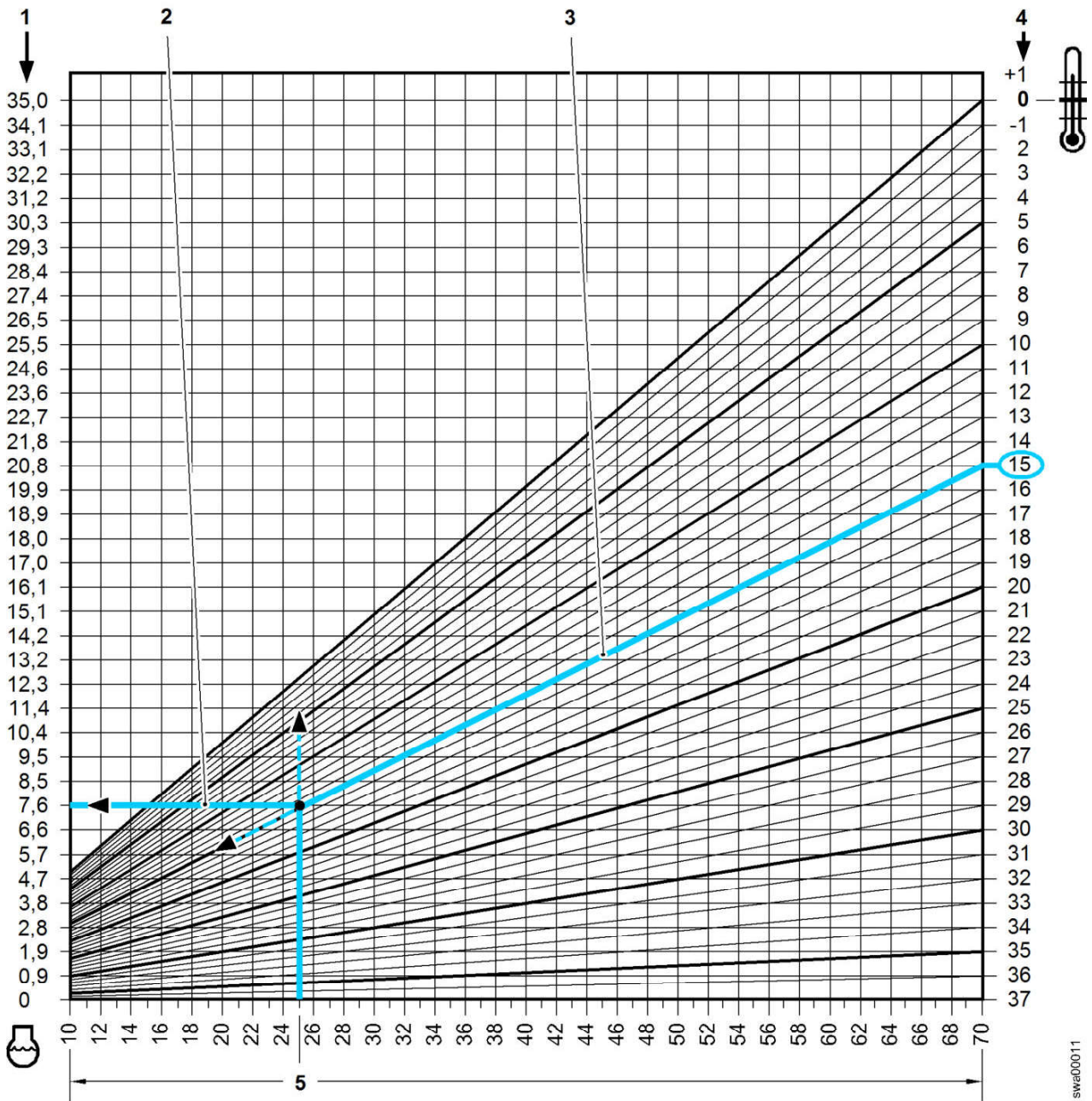

Fig. 488: Selection for antifreeze concentration

- | | | |
|---|--|--|
| <p>1 Amount of pure antifreeze to be added in litres</p> <p>2 Identified line - top-up quantity</p> | <p>3 Guide line(s) - example -15 °C</p> <p>4 Measured coolant freezing point in °C</p> | <p>5 Total capacity of cooling system in litres (example 25 litres)</p> |
|---|--|--|

Example procedure

Assumption:

- 25 litres total filling quantity of the cooling system
- 15 °C coolant temperature, measured in the cooling system

► In the diagram, go to the line showing the overall cooling system capacity 5 at 25 litres and follow it upwards.

LBH/11652808/07/01-2015/en

swa00011

5.10 Steering system

5.10.1 Testing the steering

Make sure that:

- The working attachment is in the transport position
- The articulation lock is open
- There is enough space to test the steering

Procedure



CAUTION

Beware of accidents

- ▶ Do not allow anyone into the danger area while the test is being conducted.
 - ▶ Perform the test on level ground with no obstacles.
-

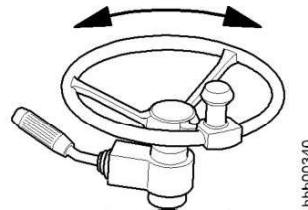

bbb00340

Fig. 501

- ▶ Start the engine.
- ▶ Without moving the machine, turn the steering in both directions and check that it is functioning properly.

5.16 Central lubrication system

5.16.1 Checking the lubrication system grease reservoir level

Make sure that the machine is in maintenance position 1.

Procedure

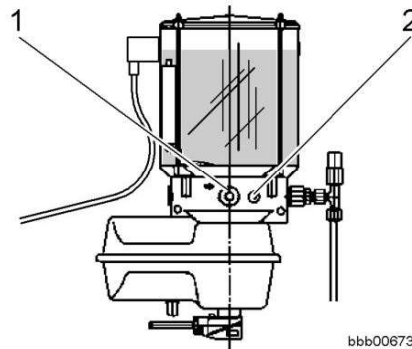

Fig. 513

Regularly check the grease quantity in the reservoir.

Stay within the minimum and maximum lubricant levels.

The reservoir has a sight glass where the rubber stripper on the agitator can be seen.



bsym0049

- ▶ Look through the sight glass to check the level in the grease reservoir.



bbb00570

If the grease in the reservoir container is too low, all 3 LEDs on the central lubrication system button light up.

NOTICE

Beware of damaging the system.

- ▶ Only fill the reservoir using the filling coupling or grease nipple.
 - ▶ Pay attention to cleanliness when filling.
-
- ▶ Fill the reservoir if necessary via the filling coupling **1** (fast filling) or the grease fitting **2**.
 - ▶ **Grease specifications:**



06sy09ab

5.19 Cleaning the machine

5.19.1 Washing the machine

Make sure that the machine is in maintenance position 2.



CAUTION

Risk of accidents from the high-pressure jet of the high-pressure cleaner.

- ▶ Wear appropriate protective clothing and safety glasses.

Cleaning the machine

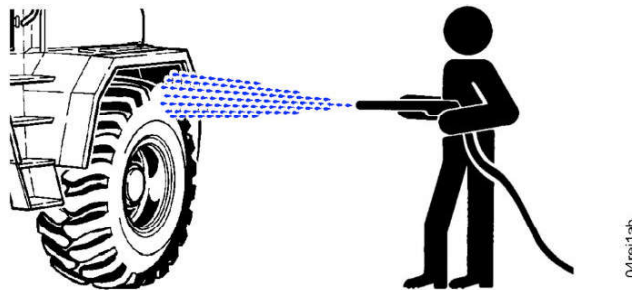

Fig. 531: Washing

Electrical devices such as the emergency steering pump, refuelling pump, sensors and electric components in the cab are not watertight.

Be careful when cleaning the machine with a high-pressure cleaner.

Every time you clean the machine with a high-pressure cleaner, regrease all lubrication points on the machine.

NOTICE

Freshly painted surfaces may be damaged.

High-pressure cleaning [more than 1379 kPa (13.8 bar)] can damage freshly painted surfaces.

- ▶ When a new machine is delivered, let the paint dry in the air for at least 30 days before you wash it or parts of it with a high-pressure cleaner.
- ▶ Until this 30 day period has passed, only use a low-pressure cleaner for washing.

NOTICE

Beware of damaging the soundproofing mats.

The soundproofing mats can be damaged if you clean them with high pressure. Damaged soundproofing mats increase the sound output level above that guaranteed by the manufacturer.

- ▶ Do not expose soundproofing mats to water or steam jets.

CLICK HERE TO **DOWNLOAD** THE COMPLETE MANUAL

- Thank you very much for reading the preview of the manual.
- You can download the complete manual from: www.heydownloads.com by clicking the link below



- Please note: If there is no response to CLICKING the link, please download this PDF first and then click on it.

CLICK HERE TO **DOWNLOAD** THE COMPLETE MANUAL