

en

Operating manual

Wheel loader

L 566-1168 (USA / CAN)

From serial number 27707

Document ID

	ORIGINAL OPERATING MANUAL
Order number:	11340740
Issued:	10-2013
Version:	06
Author:	LBH / Technical Documentation Department

Product ID

Manufacturer:	Liebherr-Werk Bischofshofen GmbH
Type:	L 566 (USA / CAN)
Type no.:	1168
Serial no. from:	27707

Conformity:



Contact

Address:	Liebherr-Werk Bischofshofen GmbH Dr. Hans Liebherr-Straße 4 A – 5500 Bischofshofen
-----------------	--

CLICK HERE TO **DOWNLOAD** THE COMPLETE MANUAL

- Thank you very much for reading the preview of the manual.
- You can download the complete manual from: www.heydownloads.com by clicking the link below



- Please note: If there is no response to CLICKING the link, please download this PDF first and then click on it.

CLICK HERE TO **DOWNLOAD** THE COMPLETE MANUAL

3	Handling and operation	71
3.1	Control elements	71
3.1.1	Driver's cab	71
3.2	Handling	73
3.2.1	Battery main switch	73
3.2.2	Articulation lock	73
3.2.3	Cab access	74
3.2.4	Right hinged window	76
3.2.5	Emergency exit	77
3.2.6	Fire extinguisher	78
3.2.7	Driver's seat	79
3.2.8	Seat belt	88
3.2.9	Steering column and steering wheel	89
3.2.10	Control panel	91
3.2.11	Start switch	91
3.2.12	Electronic drive interlock	92
3.2.13	Driver identification	95
3.2.14	Steering column switch	98
3.2.15	Lighting	98
3.2.16	Interior lighting of the driver's cab	102
3.2.17	Display	103
3.2.18	Control units	123
3.2.19	Switches for optional equipment	131
3.2.20	Control lever	134
3.2.21	Control lever with mini-joystick	138
3.2.22	Additional control lever	146
3.2.23	Controlling the optional attachment	148
3.2.24	Heating and air conditioning system	151
3.2.25	Rear window heater and mirror heater (optional)	154
3.2.26	Interior and exterior mirrors	155
3.2.27	Sun visor	156
3.2.28	Radio	156
3.2.29	Windscreen wiper and washer system	156
3.2.30	Liebherr automatic central lubrication system	158
3.2.31	Back-up alarm	161

Rear axle

Oscillating planetary axle

Description	Unit	Value
Width	mm ft-in	2230 7' 4"
Automatic self-locking differential	% %	45 45
Angle of articulation to each side	° °	13 13
Height of obstacles which can be driven over	mm ft-in	490 1' 7"

1.2.7 Braking

The braking system complies with the roadworthiness certification regulations.

Service brake

Self-arrest of hydrostatic travel drive, acting on all four wheels.

Additional pump accumulator brake system with wet disc brakes (two separate brake circuits).

Parking brake

Electrohydraulic spring accumulator brake system on the gearbox.

1.2.8 Steering

Type:

- Load sensing swash plate variable displacement pump with pressure cut-off and flow regulator.
- Central articulated joint with two dual-action steering cylinders with shock absorbers.

Emergency steering: electrohydraulic emergency steering system

Description	Unit	Value
Angle of articulation to each side	° °	40 40

1.2.9 Working hydraulics

- Load sensing swash plate variable displacement pump with power regulator and flow regulator, pressure cut-off in control valve block.
- Hydraulic oil cooling with thermostatically controlled fan and oil cooler.
- Return filter in the hydraulic tank.
- Single-lever control, hydraulic servo system.

	Designation	Unit	Value	
F	Reach at maximum lifting height and 45° tilt-out angle	mm in	1180 3' 10"	1240 4' 1"
G	Digging depth	mm in	100 3.94"	100 3.94"
H	Height above cab	mm in	3590 11' 9"	3590 11' 9"
I	Height above exhaust	mm in	3000 9' 10"	3000 9' 10"
J	Ground clearance	mm in	535 1' 9"	535 1' 9"
K	Wheelbase	mm in	3780 12' 5"	3780 12' 5"
L	Overall length	mm in	9260 30' 5"	9340 30' 8"
	Turning radius over bucket outer edge	mm in	7580 24' 10"	7600 24' 11"
	Breakout force (SAE)	kN lb _f	200 44,960	190 42,710
	Tipping load when straight	kg lb	18195 40,113	17780 39,198
	Tipping load articulated at 37°	kg lb	16100 35,494	15760 34,744
	Tipping load articulated at 40° (ISO 14397-1)	kg lb	15750 34,722	15430 34,017
	Operating weight	kg lb	23150 51,036	23250 51,257

Tab. 7: Complete machine with bucket (Z kinematics)

- A) Z kinematics
 B) Earth bucket with short, straight base for direct attachment
 C) Welded tooth holder with plug-in teeth
 D) In practice, the bucket capacity can be around 10% greater than as calculated using the ISO 7546 standard.
 The bucket filling level depends on the type of material.

1.2.21 High lift attachment (Z kinematics)

The values stated refer to the machine:

- In its standard version
- With 26.5R25 L3 tyres ([For more information see: 1.2.17 Tyres, page 25](#))
- Including all lubricants
- With a full tank
- With ROPS/FOPS cab and driver

Tyre sizes and additional attachments affect the operating weight and tipping load.

	Designation	Unit	Value
B	Manipulation height	mm in	5125 16' 10"
C	Maximum grabber opening in loading position	mm in	2650 8' 8"
C1	Maximum grabber opening	mm in	3050 10'
E	Maximum height	mm in	7400 24' 3"
F20	Reach at maximum lifting height and 20° tilt-out angle	mm in	2165 7' 1"
F45	Reach at maximum lifting height and 45° tilt-out angle	mm in	1620 5' 4"
F max.	Maximum reach	mm in	3110 10' 2"
H	Height above cab	mm in	3590 11' 9"
I	Height above exhaust	mm in	3000 9' 10"
J	Ground clearance	mm in	535 1' 9"
K	Wheelbase	mm in	3780 12' 5"
L	Overall length	mm in	9880 32' 5"
	Machine width across tyres	mm in	2970 9' 9"
Q	Grabber cross section	m ² yd ²	3.1 3.71
	Grabber width	mm in	1800 5' 11"
	Payload	kg lb	8200 ^{B)} 18,078 ^{B)}
	Operating weight	kg lb	25.640 ^{B)} 56.53 ^{B)}

Tab. 13: Timber grabber attachment

- A) Industrial lift arms with parallel guidance including quick-change device
 B) Data includes water-filled rear tyres

Cooler decal

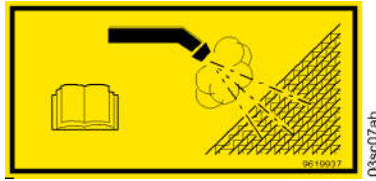

Fig. 31: Cooler decal

Indicates cleaning of the cooling system.

Lashing point decal



Fig. 32: Lashing point decal

Indicates the lashing points on the machine.

Slings and lifting point decal

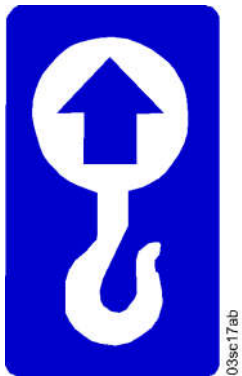

Fig. 33: Slings and lifting point decal

Indicates the slings and lifting points on the machine.

- Exceeding the maximum speed causes the permitted limits to be exceeded for all rotating parts, including the drive motor, the drive shaft, all gears including axles and ultimately the engine itself.
2. Before driving onto a slope, therefore select a travel range (gear) in which you can safely negotiate the whole slope without endangering yourself, the machine and other people.
 3. Also, take your foot off the gas pedal when driving onto a slope.

2.4.8 Parking safely

1. When possible, always park the machine on flat, firm ground.
If you have to park on a slope, use wheel wedges to prevent the machine from moving.
2. If the machine has articulated steering, engage the articulation lock.
This only applies to wheel loaders with articulated steering.
3. Lower the digging attachment so that it is lightly anchored in the ground.
4. Move all control levers to the neutral position and engage the parking brake.
5. Shut down the engine in accordance with the instructions in the “**operating manual**” .
6. Lock the working hydraulics before leaving the driver's cab.
Lock the working hydraulics in accordance with the instructions in the “**operating manual**”.
7. Lock up the machine, take out all keys and secure it against unauthorised use and vandalism.

2.4.9 Transporting the machine safely

1. Only use suitable transport equipment and lifting gear with sufficient load capacity.
2. Park the machine on flat ground and use wedges to secure the tracks or wheels.
3. If necessary, dismantle the working attachment for the duration of transport.
4. The ramp for driving onto the low-bed truck must not be steeper than 30° and should be covered with wooden boards to prevent slipping.
5. Clean the machine tracks or wheels of snow, ice and mud before driving onto the ramp.
6. Before driving on, secure the upper carriage to the undercarriage with the locking pin.
Procedure: does not apply to wheel loaders.
7. Align the machine precisely with the loading ramp.
8. Attach the hand lever to the pedals for sensitive driving.
Procedure: does not apply to wheel loaders.
9. Have someone give signals to direct the driver.
Drive carefully onto the ramp and then on to the transport vehicle itself.
10. Have wedges ready to prevent the machine from rolling back when driving on.
11. Tilt the attachment in and drive onto the ramp.
Keep the attachment close to the loading area.
12. After driving on, lower the working attachment onto the loading area.
Apply the articulation lock (this only applies to wheel loaders with articulated steering).
13. Secure the machine and the remaining individual components against slipping using chains and wedges.
14. Relieve the pressure lines, take out the ignition key, lock the cab door and side panels, and get out of the machine.
15. Acquaint yourself with the route before transport, especially as regards the width, height and weight limits you will encounter.

3 Handling and operation

3.1 Control elements

3.1.1 Driver's cab

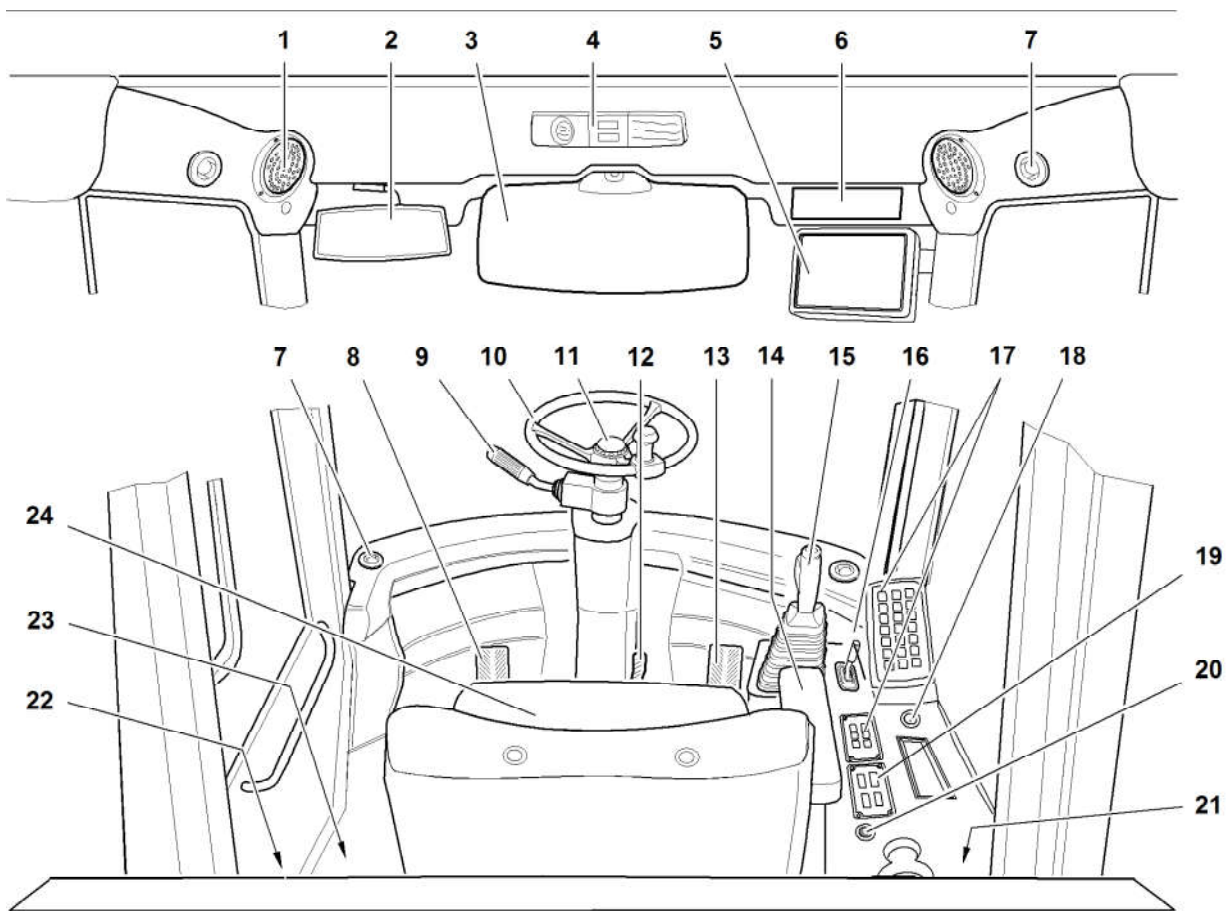

Fig. 49: Driver's cab

- | | | |
|---------------------|---|-----------------------------|
| 1 Radio speaker | 9 Stalk switch | 17 Control units |
| 2 Interior mirror | 10 Steering wheel | 18 Start switch |
| 3 Sun visor | 11 Steering wheel hub for steering wheel height adjustment (option) | 19 Optional switch |
| 4 Interior lighting | 12 Lever for steering wheel distance adjustment | 20 Cigarette lighter socket |
| 5 Display | 13 Gas pedal | 21 Diagnostic plug |
| 6 Radio compartment | 14 Adjustable arm rest | 22 Fuse box |

See next page for continuation of the image legend

LBH/11340740/06/10-2013/en

b0000483

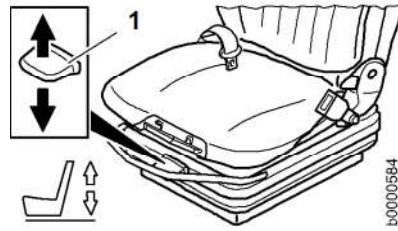

Fig. 63: Adjusting the seat height

1 Seat height adjustment lever

- ▶ Pull or push the lever 1 fully until it reaches the required height.
 - ▷ When it reaches the top or bottom limit, the height is adjusted automatically to the minimum required suspension.

Premium seat

Make sure that the automatic seat suspension adjustment is completed. (For more information see: [Adjusting the seat suspension, page 79](#))

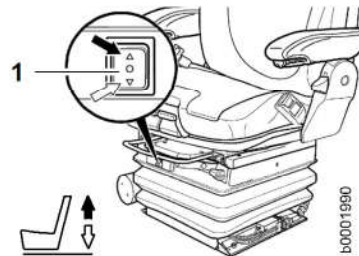

Fig. 64: Adjusting the seat height

1 Seat height adjustment button

- ▶ Press button 1 until the required seat height is reached.
 - ▷ When it reaches the top or bottom limit, the height is adjusted automatically to the minimum required suspension.

Adjusting the arm rest

Standard seat / comfort seat / premium seat

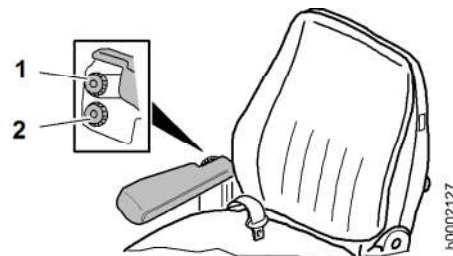

Fig. 65: Adjusting the arm rest

- 1 Horizontal adjustment, inclination adjustment screw 2 Screw for height adjustment

LBH/11340740/06/10-2013/en

3.2.10 Control panel

The control panel is located to the right of the driver's seat. It can be adjusted to suit the seat position and arm length of the driver.

Adjusting the control panel.



Fig. 85: Adjusting the control panel.

1 Pedal

2 Control panel



WARNING

The working attachment can cause accidents if it is accidentally actuated.

► Only adjust the control panel when the vehicle is stationary with the working hydraulics lockout activated or with the engine switched off.

► Push down the pedal 1 and at the same time push the control panel 2 forward or pull it back.

► Release the pedal 1.
▷ The control panel 2 is fixed in place.

3.2.11 Start switch



Fig. 86: Start switch

1 Ignition key

0 0-position / engine shut-down

See next page for continuation of the image legend

LBH/11340740/06/10-2013/en



Fig. 99: Switching on the working headlights

- 1 Working headlight button
- 2 Front working headlight LED
- 3 Rear working headlight LED

- ▶ Press the button 1.
 - ▷ The LED 2 lights up
 - ▷ The front working floodlight is switched on.
- ▶ Press the button 1 again.
 - ▷ The LEDs 2 and 3 light up.
 - ▷ The front and rear working floodlights are switched on.

To switch off the working headlights:

- ▶ Press the button 1 again.
 - ▷ The LED 3 lights up
 - ▷ The front working floodlight goes out.
- ▶ Press the button 1 again.
 - ▷ No LED on the button lights up.
 - ▷ The front and rear working floodlights are switched off.

Activating the direction indicators

Make sure that the electrical system of the machine is switched on.



Fig. 100: Activating the direction indicators

- 1 Steering column switch
- a Right direction indicator
- b Left direction indicator

- ▶ Move the steering column switch 1 in direction a.
 - ▷ *Flashing lights* symbol field in the display flashes.
 - ▷ The right direction indicators are activated.
- ▶ Move the steering column switch 1 in direction b.
 - ▷ *Flashing lights* symbol field in the display flashes.

LBH11340740/06/10-2013/en

Item	Designation
3	Coolant temperature indicator White symbol – normal mode Red symbol – coolant temperature too high
4	Hydraulic oil temperature indicator White symbol – normal mode Red symbol – hydraulic oil temperature too high
5	Battery voltage indicator White symbol – normal mode Red symbol – battery voltage too low or too high

Tab. 24: Displaying units

System settings

You can make the following system settings:

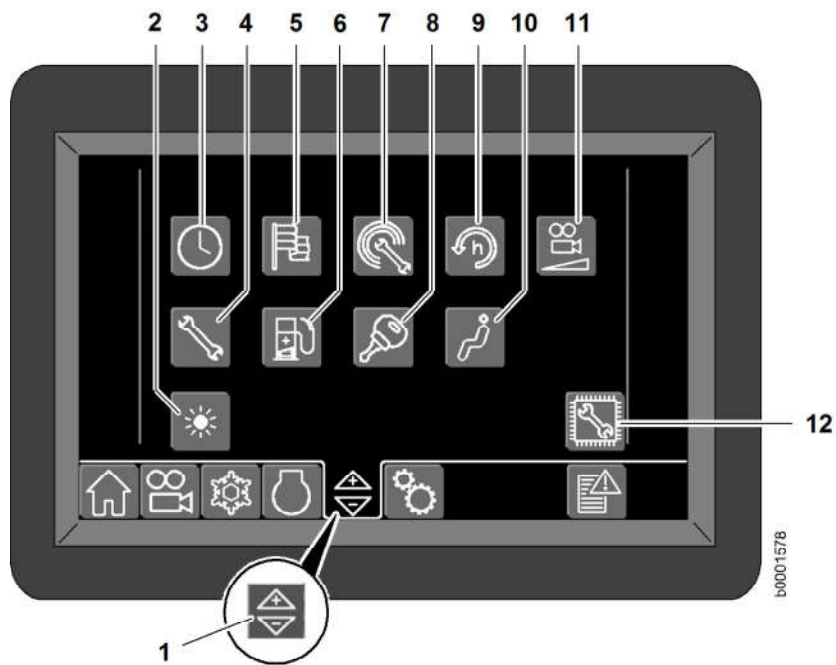

Fig. 109: System settings

Item	Designation
1	System settings selector button
2	Display brightness setting selector button
3	Clock and time zone setting selector button
4	Service management selector button
5	Language setting selector button
6	Fuel consumption indicator selector button

LBH/11340740/06/10-2013/en

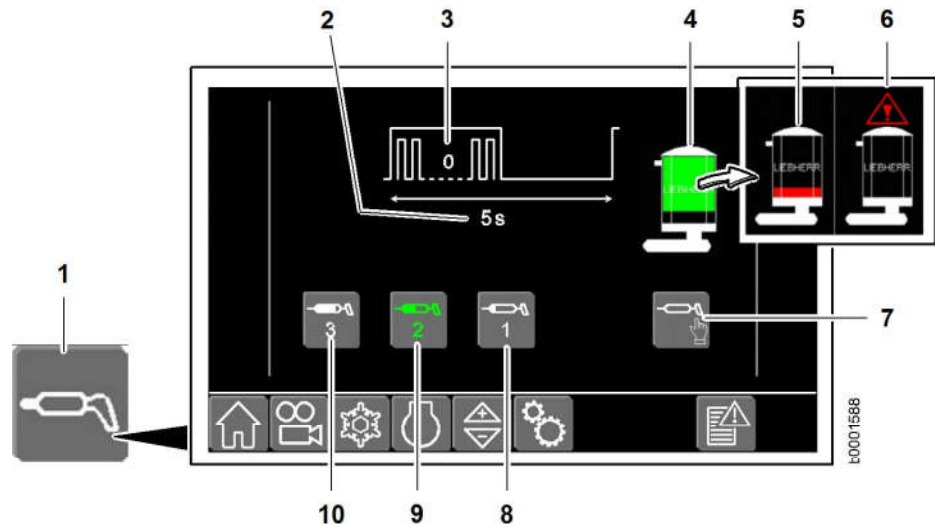

Fig. 124: Liebherr automatic central lubrication system

- | | |
|---|--|
| 1 Central lubrication system selector button | 6 Filling level malfunction indicator |
| 2 Time until next lubrication (in seconds) | 7 Non-scheduled lubrication |
| 3 Remaining lubrication cycles | 8 Central lubrication system mode 1 (light duty) |
| 4 Maximum filling level indicator | 9 Central lubrication system mode 2 (medium duty) |
| 5 Filling level low indicator | 10 Central lubrication system mode 3 (heavy duty) |

- ▶ Press the selector button **1** to open the display screen.
- ▶ Use the buttons **8**, **9** and **10** to set the lubrication intensity.
 - ▷ Active settings are shown by a flashing green button.
 - ▷ If the filling level is low **5**, the indicator flashes red.
 - ▷ If a malfunction **6** occurs, a service code appears in the display.
- ▶ Use the button **7** to initiate an additional non-scheduled lubrication during the lubrication cycles.

Tachometer

This equipment is optional.

Temperature down button

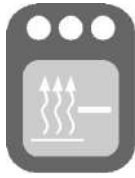

bbb00558

Reduces the temperature.

- With manual air conditioning, the temperature is adjusted in 6 levels.
- With automatic air conditioning, the temperature is adjusted between 16 °C (61 °F) and 28 °C (82 °F).

Each time you press the button, the LEDs light up according to the temperature level.

The set temperature is briefly shown in the display.



Note

The setting remains stored after the ignition is switched off.

- ▶ This means the function is active when the ignition is switched on again.

3.2.19 Switches for optional equipment

The switches have indicator lamps. When you switch a function on or off, the indicator lamps light up or go out.



b0000838

Fig. 156: Switches for optional equipment

- 1 Switch panel for options

Quick-change device button

This equipment is optional.

Field colour *red*

For locking and unlocking the hydraulic quick-change device.

Button functions:

- 0 - The quick-change device is locked (no warning tone)
- I - Unlocks the quick-change device (warning tone)
- II - Locks the quick-change device (no warning tone)

(For more information see: [3.5.1 Removing the working attachment from the quick-change device, page 212](#))

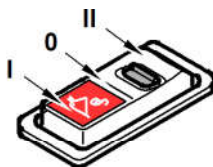

b0000284

- ▶ a - Raise the lift arms.
- ▶ b1 - Lower the lift arms.
- ▶ b2 - Quickly lower the lift arms.
- ▶ c - Tilt bucket in.
- ▶ d - Tilt bucket out.
- ▶ e - Raise lift arms and tilt bucket in at the same time.
- ▶ f - Lower lift arms and tilt bucket out at the same time.
- ▶ g - Raise lift arms and tilt bucket out at the same time.
- ▶ h - Lower lift arms and tilt bucket in at the same time.

Mini-joystick

The working attachment can be controlled with a high degree of sensitivity, i.e. the further the mini-joystick is pushed in one direction, the faster the motion of the additional equipment.

Controlling the hydraulic working attachment

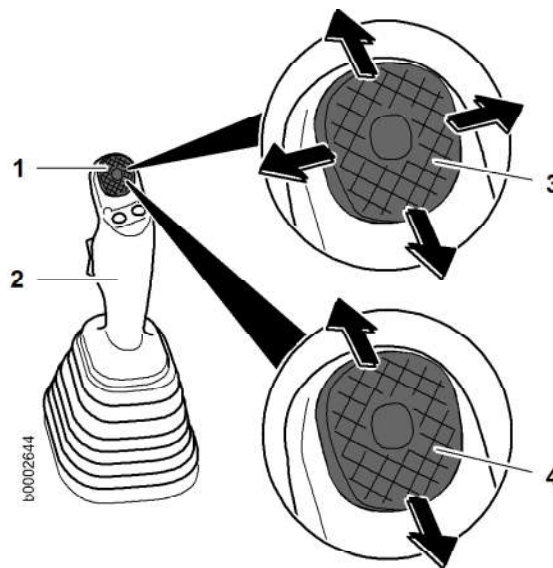

Fig. 178: Controlling the hydraulic working attachment

- | | |
|-----------------|----------------------------|
| 1 Mini-joystick | 3 Mini-joystick, biaxial |
| 2 Control lever | 4 Mini-joystick, monoaxial |

- ▶ Grip the control lever 2 in your hand.
- ▶ Push the mini-joystick 1 in the desired direction of motion.
 - ▷ The hydraulic working attachment is controlled (for example opening and closing a timber grabber).



Note

To control the hydraulic working attachment:

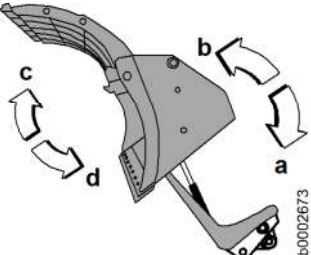
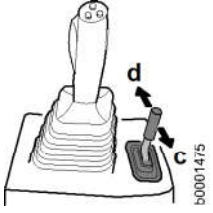
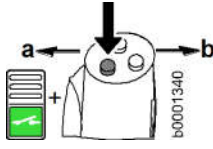
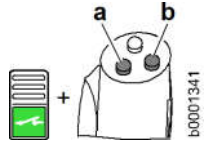
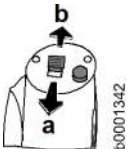
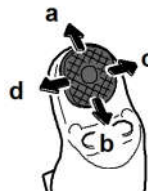

- ▶ Familiarise yourself with the functions of the working attachment.
- ▶ (For more information see: [3.2.23 Controlling the optional attachment, page 148](#))

LBH/11340740/06/10-2013/en

High dump bucket with hold-down device	Control system		
 <p>b0002673</p>	 <p>b0001475</p>	 <p>b0001340</p>	 <p>b0001341</p>
	 <p>b0001342</p>	 <p>b0002634</p>	

Tab. 34: High dump bucket with hold-down device control

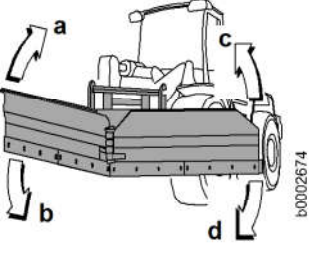
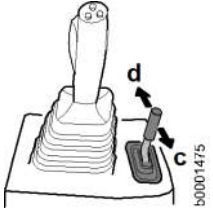
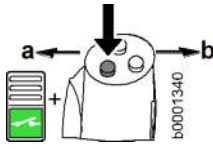
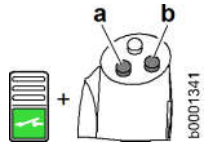
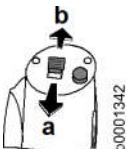
A) Operating this equipment requires a fourth control circuit.

Hinged snowplough	Control system		
 <p>b0002674</p>	 <p>b0001475</p>	 <p>b0001340</p>	 <p>b0001341</p>
	 <p>b0001342</p>	 <p>b0002634</p>	

Tab. 35: Hinged snowplough control

A) Operating this equipment requires a fourth control circuit.

3.2.24 Heating and air conditioning system

The heater heats the air as required, according to the temperature setting.

The air flow can be adapted as required using the fan.

In air conditioning mode, the air is cooled and dried.

LBH/11340740/06/10-2013/en

CLICK HERE TO **DOWNLOAD** THE COMPLETE MANUAL

- Thank you very much for reading the preview of the manual.
- You can download the complete manual from: www.heydownloads.com by clicking the link below



- Please note: If there is no response to CLICKING the link, please download this PDF first and then click on it.

CLICK HERE TO **DOWNLOAD** THE COMPLETE MANUAL



Fig. 203: Non-scheduled lubrication

1 Central lubrication system button 2 LEDs

- ▶ Briefly press the button 1.
 - ▷ The pump performs the selected lubrication cycle.

Filling the grease reservoir

- ▶ (For more information see: [5.18.1 Checking the lubrication system grease reservoir level, page 328](#))



Note

If the lubricant reservoir is fully emptied:

- ▶ Bleed the central lubrication system.

Bleeding the central lubrication system

- ▶ Contact Liebherr customer service.

Cycle error

If the set cycles could not be performed in the time specified:

- All the LEDs on the *central lubrication system* button flash.
- The service code is shown on the display.

Possible causes:

- Engine is defective
- Lubrication point, lubricant supply line or distributor blocked

To rectify faults:

- ▶ Contact Liebherr customer service.

3.2.31 Back-up alarm

This equipment is optional.

The back-up alarm system warns anyone standing behind the machine while it is reversing.

Versions:

- Audible back-up alarm
- Visible back-up alarm

The back-up alarms can also be installed in combination.

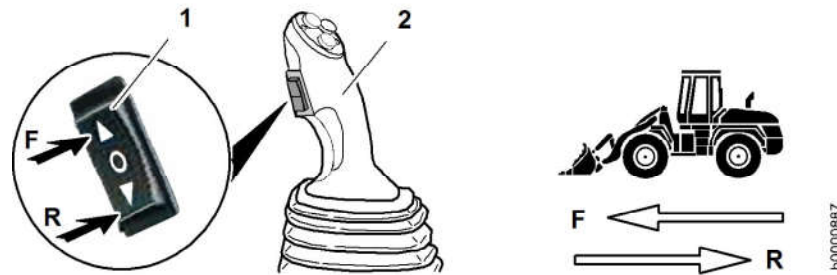

Fig. 216: Selecting the travel direction

- | | | | |
|----------|--------------------------|----------|--------------------------|
| 1 | Travel direction switch | R | Reverse travel direction |
| 2 | Control lever | 0 | Neutral travel direction |
| F | Forward travel direction | | |

- ▶ Use the switch **1** to select the travel direction.
 - ▷ Travel direction symbol field in the display lights up.

Driving

This section deals with the following topics:

- Setting off
- Overspeed protection
- Driving with kick-down shifting
- Driving with the Vmax (speed restriction) function
- Driving with ride control
- Reversing
- Tractive force adjustment

Setting off

Make sure that you have completed all the preparations for driving. (For more information see: [Preparations for driving, page 169](#))

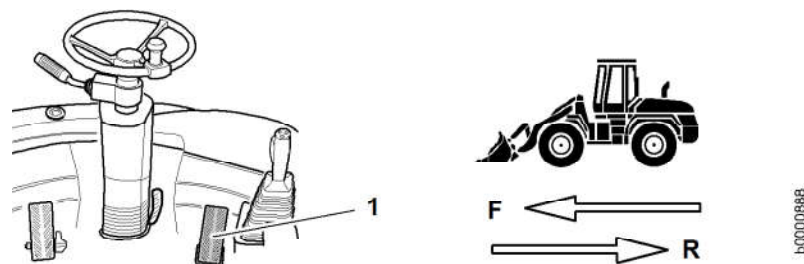

Fig. 217: Setting off

- | | |
|----------|-------------------|
| 1 | Accelerator pedal |
|----------|-------------------|

- ▶ Press down the accelerator pedal **1** carefully.
 - ▷ The machine starts moving.
 - ▷ The travel speed and gear are shown in the display.

Overspeed protection

The overspeed protection function prevents the machine from travelling too fast down steep slopes. This to ensure the safety of the machine and driver. If a particular speed is exceeded, the function is activated and automatically decelerates the machine. Overspeed protection acts independently of the travel direction in any travel range.

LBH/11340740/06/10-2013/en

Parking position

The ignition key cannot be pulled out in the parking position P.



Fig. 231: Parking position

- ▶ Turn the ignition key to the parking position P.
- ▶ You can keep the battery main switch turned on when parking the machine on public roads.
The consumer units listed below are ready for operation:
 - ▷ Interior lighting
 - ▷ Hazard warning system
 - ▷ Socket/cigarette lighter
 - ▷ Front working floodlights
 - ▷ Flashing beacon (optional)
 - ▷ Radio (optional)
 - ▷ Rear working headlight (optional)



DANGER

If an unauthorised person tampers with the machine, this may pose a severe accident risk for the maintenance personnel.

- ▶ Secure the machine against access by unauthorised persons.

When leaving the machine:

- ▶ Turn the ignition key to the 0 position and pull it out.
 - ▷ Any power consumers can be switched on at the instrument panel. (For more information see: [3.2.11 Start switch, page 91](#))

3.3.6 Automatic engine shutdown

This equipment is optional.

The engine shuts down automatically if it runs for longer than 5 minutes at a speed below 1000 min⁻¹ (1000 rpm).

3.3.7 Moving working attachments

The movements of the lift arms and the bucket are controlled by the control lever.

Working movements:

- Raising and lowering the lift arms
- Tilting the bucket in and out
- Moving the lift arms and the bucket simultaneously
- Float position
- Lift kick-out
- Automatic bucket return-to-dig

Automatic regeneration mode

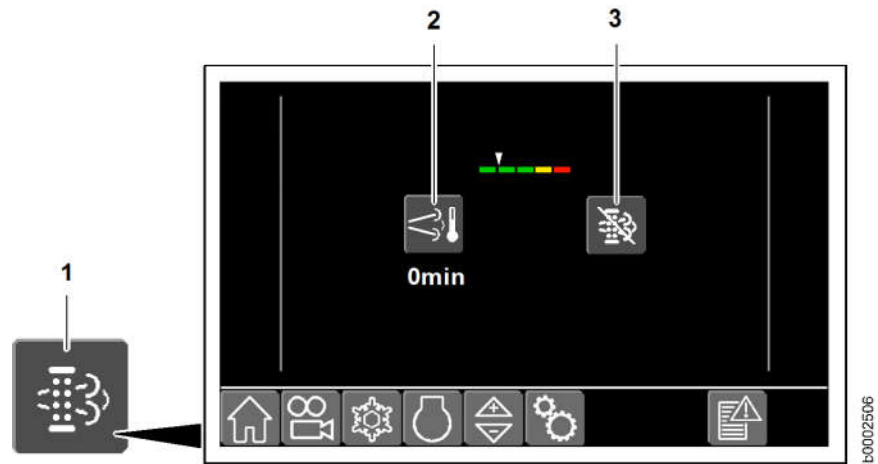

Fig. 245: “Automatic” regeneration mode

- | | |
|--|---|
| <p>1 Regenerate diesel particulate filter selector button</p> <p>2 Manual regeneration mode button</p> | <p>3 Regeneration mode disabled button</p> |
|--|---|

- ▶ Call up display screen using the selector button **1**.
- ▶ Set the button **2** to the colour “white”.
 - ▷ Regeneration of the diesel particulate filter is permitted.
- ▶ Set the button **3** to the colour “white”.
 - ▷ Automatic regeneration of the diesel particulate filter is selected.
 - ▷ Regeneration starts according to the operating condition of the diesel particulate filter.
 - ▷ The symbol field **2** (see: fig. 244, page 190) lights up at an exhaust temperature above 300 °C (572 °F) at the outlet of the exhaust pipe.



Note

If necessary, regeneration of the diesel particulate filter can be interrupted at any time.

- ▶ To do this, switch to disabled mode.

- ▶ When driving on slopes, always keep the load uphill.
- ▶ Never drive across slopes.
- ▶ Never turn on slopes.

3.3.13 2-in-1 steering

This equipment is optional.

2-in-1 steering is a fully hydraulic dual steering function.

Steering modes:

- Conventional steering mode
- Direct steering mode to simplify work with repeated steering movements

Conventional steering of the machine takes priority. Direct steering mode is deactivated when the ignition is "OFF". The respective steering mode is kept in emergency steering operation.



WARNING

Incorrect steering can cause accidents.
Beware of people standing in the working area.

- ▶ Only use direct mode at a speed you can control.

When driving on public roads:

- ▶ Deactivate direct steering mode.

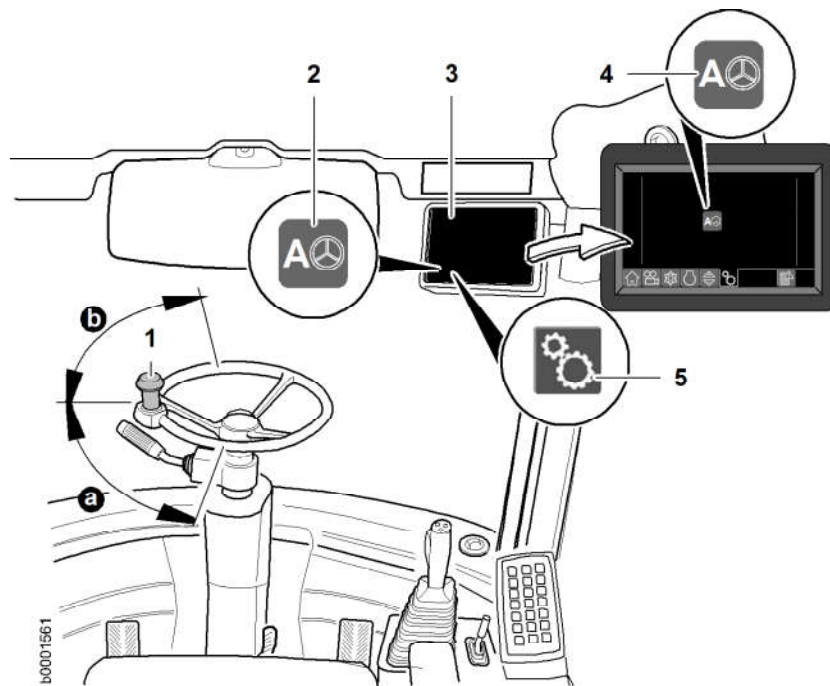

Fig. 257: Activating direct steering mode

- | | | | |
|---|-----------------------------|---|-----------------------------------|
| 1 | Steering knob | 5 | Function settings selector button |
| 2 | Button 2-in-1 steering | a | Steering range left |
| 3 | Display | b | Steering range right |
| 4 | Direct steering mode button | | |

Activating direct steering mode

LBH/11340740/06/10-2013/en

Excavating foundations

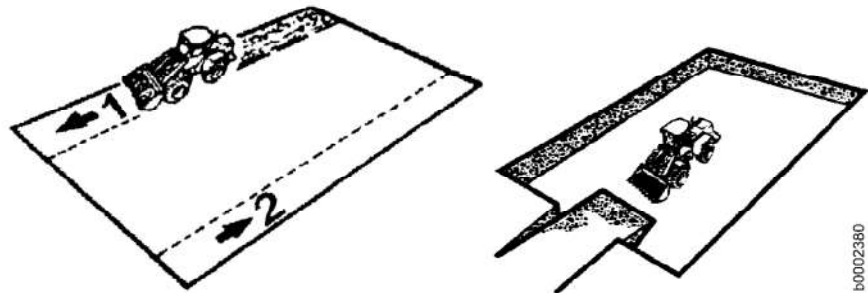

Fig. 273: Excavating foundations

- ▶ Make a first trench along the side of the pit.

When the first trench is down to a depth of 1 m (3' 3" ft-in):

- ▶ Start a second trench along the opposite side.
- ▶ Excavate the middle area to the same depth as the two side trenches. Heap the material at one side.

When the foundations have been excavated to the required depth:

- ▶ Use the heaped material to create an exit ramp.
- ▶ Drive forwards out of the pit.

- ▶ Carefully drive the machine to the loading area and stop.
- ▶ Engage the parking brake.
- ▶ Engage the articulation lock.
- ▶ Lower the lift arms and lay the bucket down flat on the loading area.
- ▶ Turn off the engine.
- ▶ Close and lock the doors, hatches and hoods on the machine.

Securing the machine

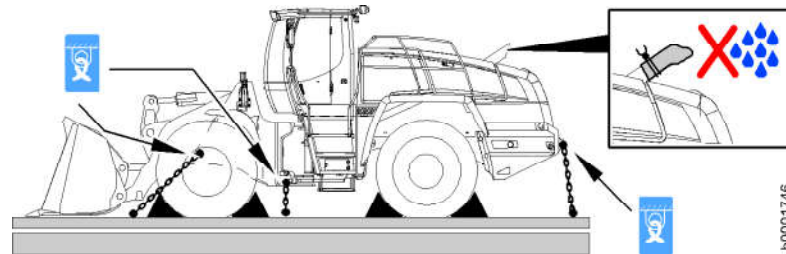

Fig. 282: Securing the machine

- ▶ Secure the machine against slipping, using wheel wedges and tensioning ropes or chains.
- ▶ Fasten the ropes and chains to the indicated lashing points on the machine.

NOTICE

Beware of damaging the exhaust system.
Water or moisture entering can destroy the exhaust system.

- ▶ Prevent water or moisture from entering the exhaust system.
- ▶ Seal the exhaust system using waterproof material which cannot slip.

3.6.2 Transport safety retainer

This only affects devices with P kinematics.

When transporting wheel loaders from the plant without installed attachments or a quick-change device transport safety retainers are installed at the lift arms and the control lever.

Removing the transport safety retainer

Make sure that the following requirements are fulfilled:

- Park the machine on level ground.
- Lower the lift arms.
- Engage the parking brake.
- Turn off the engine.

4 Malfunctions

Warning and error messages:

- Various faults are indicated by corresponding symbols or service codes in the display.
- Some warning functions are accompanied by audible warning signals.

Finding and eliminating errors and malfunctions:

- Faults can often be traced back to incorrect operation or servicing of the machine.
Therefore, carefully read the appropriate section of the operating manual each time a fault occurs.
- **Analyse the cause of the fault and correct it immediately.**
- Describe the fault and all related circumstances if you contact **Liebherr Customer Service**. Precise information helps to locate and eliminate the cause of the fault. This means that the exact type and serial number of the machine need to be stated.
- Never perform any work for which you have not been trained or instructed.



Note

If cause of the fault cannot be detected or eliminated using the service code table.

- ▶ Contact Liebherr customer service.
-

4.1 Servicecodes

4.1.1 Service code indicator in the display

The control system monitors many of the machine's functions.













It monitors for short circuits, cable rupture, external voltage and incorrect input and output signals.

In addition, the controller continuously checks the program sequence and communication with the control modules.

4.2 Problems - Cause - Remedy

4.2.1 Warning symbols

The following table contains explanations of warning symbols, causes and remedies.

Symbol in the display	Meaning	Cause	Remedy
	Engine oil pressure too low	Engine oil pressure too low	Switch off the machine, contact Liebherr customer service
	Coolant temperature too high	Coolant temperature over 100 °C (212 °F)	Clean the cooling system, contact Liebherr customer service
	Fuel level too low	Fuel tank is empty	Refuel
	Brake accumulator pressure too low	Service brake not working correctly	Contact Liebherr customer service
	Emergency steering pump check not successfully completed	Emergency steering check not successful	Contact Liebherr customer service
	Emergency steering glows when a steering pump fault occurs	Steering pump failed, steering only possible with the emergency steering pump	Contact Liebherr customer service
	Engine speed too high	Hydraulic oil temperature over 95 °C (203 °F)	Clean the cooling system, contact Liebherr customer service
	Battery not charging	Fault in the electrical system	Contact Liebherr customer service
	Switch off the machine	Fault on the machine	Contact Liebherr customer service
	Engine warning	Engine malfunction	Contact Liebherr customer service
	Diesel particulate filter warning	High load condition of the diesel particulate filter	Regenerating the diesel particulate filter
	Service notification	Machine service is due	Contact Liebherr customer service
	Air filter contamination	The air filter is dirty	Clean/replace air filter, contact Liebherr customer service

Tab. 41: **Warning symbols**

LBH11340740/06/10-2013/en

Customer:..... Machine type:..... Serial no.:..... Service hours:..... Date:.....

Maintenance / inspection after service hours								Tasks to be performed		
On handover	All 8-10 h	All 50 h	All 500 h	All 1000 h	All 2000 h	All 3000 h	Other intervals	By maintenance staff	with authorised specialist staff	
							○4500h	■ Once-only activity ● Repeat interval † As necessary * Annually before the winter	□ Once-only activity ○ Repeat interval ✧ As necessary	
Cooling system										
			○	○	○	○		*	Checking the coolant antifreeze and corrosion inhibitor concentration	300
								†	Cleaning the cooling system	304
						○			Changing the coolant (at least every 2 years)	
Working hydraulics										
□	●	●	○	○	○	○			Checking the oil level in the hydraulic tank	306
□		■	○	○	○	○	250h		Checking and cleaning the magnetic rod on the hydraulic tank	307
			○	○	○	○			Draining off condensate and sediment from the hydraulic tank	
				○	○	○			Changing the hydraulic tank return and suction filter	
					○				Changing the hydraulic tank breather filter	
								✧	Changing the oil in the hydraulic system in accordance with oil quality and oil analysis (For more information see: Changing the oil, analysing the oil, changing filters, page 266)	
				○	○	○			Lubricating the solenoids, universal joints and tappets on the pilot control unit	
Steering system										
□	●	●	○	○	○	○			Testing the steering	309
□		●	○	○	○	○			Lubricating the bearing points on the steering cylinders	309
Brake system										
□	●	●	○	○	○	○			Testing the service brake and parking brake	310
						○			Checking the service brake discs for wear	
				○	○	○			Checking the gap and wear on the parking brake linings	
Electrical system										
□	●	●	○	○	○	○			Checking the lights	312
			○	○	○	○			Checking the batteries, fluid level and terminals	
				○	○	○			Changing the travel direction rocker switch and cap (optional) on the control lever	
Transmission										
□		●	○	○	○	○			Checking the transmission oil level	313
			□	○	○	○			Changing the transmission oil	
			□		○				Changing the transmission oil filter	
Axles and cardan shafts										
□			○	○	○	○			Checking the axle oil levels	
			□	○	○	○			Changing the axle oil	
			○	○	○	○			Checking the cardan shafts	

LBH/11340740/06/10-2013/en

Oil that is too viscous can cause starting problems, while insufficient viscosity impairs lubricating efficiency.

The temperature ranges detailed in the following diagram are guidelines; short-term deviations are permissible.

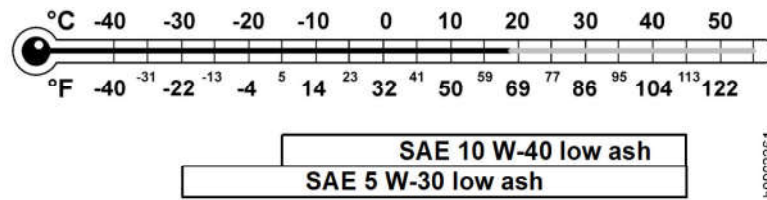

Fig. 306: Selection of the SAE class according to temperature

The following diesel engine oil is recommended for ambient temperatures from -15 °C (5 °F) to 45 °C (113 °F):

Liebherr Motoroil 10W-40 low ash, specification ACEA E6

The following diesel engine oil is recommended for ambient temperatures from -30 °C (-22 °F) to 45 °C (113 °F):

Liebherr Motoroil 5W-30 low ash, specification ACEA E6

Complicating factors affect the oil change

Change the oil according to the climate zone, sulphur content in the fuel and oil quality as shown in the following table.

Even if the specified number of service hours (h) is not reached in the course of a year, the engine oil and filter should be replaced at least once a year.

Various **complicating factors** (harsh operating conditions) can affect the maintenance interval.

Possible complicating factors:

- Frequent cold-starts
- Sulphur content in the fuel
- Operating temperature

If complicating factors come into play, the oil must be changed and the filter replaced in accordance with the specifications in the following tables.

Complicating factor		Oil quality	
		CJ-4	E6
		E9	E6
Operating conditions	Sulphur content in the fuel	Interval (h = operating hours)	
Normal climate, down to -10 °C (14 °F)	Up to 0.0015%	250 h	500 h
Climates below -10 °C (14 °F)	Up to 0.0015%	125 h	250 h

Tab. 50: Oil change intervals according to complicating factors

LBH11340740/06/10-2013/en

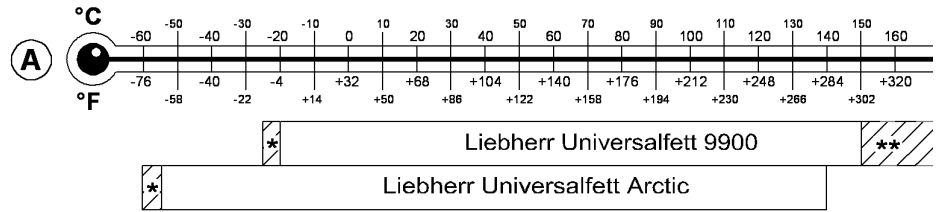

Fig. 315: Operating temperature of Liebherr lubrication greases

- A** Temperature of the lubrication grease
- **** Brief temperature peaks up to a maximum of 200 °C (392 °F) may occur.
- *** Not when used in central lubrication systems

NOTICE

There is a risk of damaging the engine and its electric components. Moisture penetration can cause corrosion and electrical malfunctions.

- ▶ Do not expose devices such as the starter, alternator, sensors and engine control unit to water or steam jets.
-

Make sure that the following requirements are fulfilled:

- The machine is in maintenance position 1.
- The engine compartment hood is open.
- ▶ Carefully clean the engine.

5.6.4 Shutting down the machine for a lengthy period

If the machine is put out of service for a longer period without preservation, this must be put back into service at 14 day intervals (at maximum) in order to prevent, for the most part, increased corrosion and the resulting damage.

- ▶ All oil levels must be checked before putting into service.
- ▶ Carry out all daily prescribed maintenance work before putting back into service each time. Carry out all additional temporary maintenance work as per inspection plan, at the latest at the intended intervals.
- ▶ Put machine back into service and operate until the engine and hydraulics system have reached the prescribed operating temperature in the hydraulic tank and in the coolant circulation (see the section on operating the “display”).
- ▶ Activate all functions of the working and travel hydraulics and of the other hydraulic components, and alternately operate over a time-span of approx. 20 minutes. Hydraulic cylinders must each be extended and retracted over their full stroke length.
- ▶ When switching off the machine, retract all the hydraulic cylinders completely if possible, and fill up the fuel tank. If the surface is soft, put the machine on wooden blocks or similar, and secure against rolling.
- ▶ Battery main switch in the OFF position.

5.6.5 Deactivating the machine

To deactivate the machine:

- ▶ Contact Liebherr customer service.

5.6.6 Checking the machine for leaks

Make sure that the following requirements are fulfilled:

- The machine is in maintenance position 2.
- The service doors, hatches and hoods are open.
- ▶ Check the hydraulic system for leaks.
- ▶ Replace any damaged hydraulic seals.
- ▶ Tighten any loose hydraulic connections.
- ▶ (For more information see: [2.4.16 Safe maintenance of hydraulic hoses and hose lines, page 66](#))



Fig. 333: Draining off condensate and sediment from the fuel tank

- | | | | |
|---|-------------|---|------------|
| 1 | Drain valve | 3 | Drain hose |
| 2 | Cap | | |

- ▶ Place a receptacle under the fuel tank.
- ▶ Unscrew the sealing cap 2 on the drain valve 1 on the bottom of the fuel tank.
- ▶ Screw the drain hose 3 onto the drain valve 1.
 - ▷ Condensate and sediment drain off.
- ▶ Drain the condensation and sediment into a suitable receptacle until clean fuel begins to flow.
- ▶ Unscrew the drain hose 3.
- ▶ Screw the sealing cap 2 onto the drain valve 1 and tighten it.

5.7.3 Draining off condensate from the Separ fuel pre-filter

When the water level probe in the Separ fuel pre-filter is activated (the corresponding service code is displayed), the water collector tank must be drained.

Make sure that the following requirements are fulfilled:

- The machine is in maintenance position 1.
- The service access is open.
- You have a suitable receptacle ready.
- The engine has cooled down.



DANGER
Beware of fire

- ▶ Naked flames and smoking are prohibited.

Correcting the antifreeze concentration



Fig. 344: Correcting the antifreeze concentration

- 1 Water cooler drain valve 2 Engine drain valve

If the antifreeze concentration is too low:

- ▶ Drain off the coolant and top up with pure antifreeze according to the following diagram.

NOTICE

Mixing different antifreeze/corrosion inhibitors can result in damage to the cooling system.

- ▶ Do not mix coolants with and without silicates.
-

NOTICE

Beware of damaging the engine.

Too much antifreeze and corrosion inhibitor impairs the cooling effect. This eventually causes damage to the engine.

- ▶ Never use more than 60% antifreeze and corrosion inhibitor.
-

Troubleshooting

If the braking effect is too slight or entirely absent?

- ▶ Contact Liebherr customer service.
-

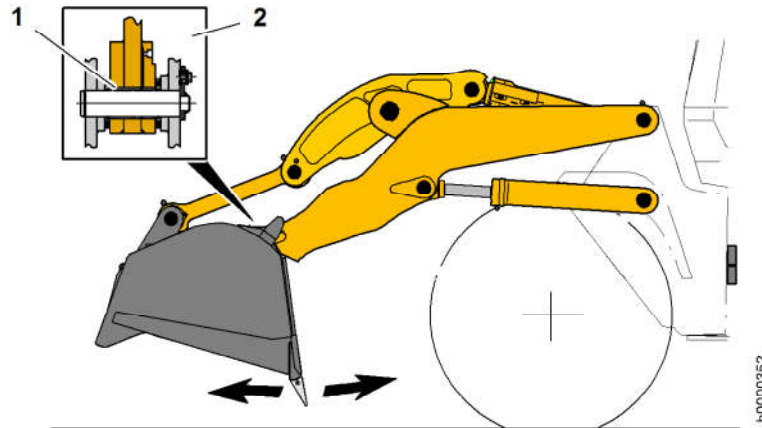

Fig. 368: Checking the bearing bushings for wear

- 1 Bearing bushing
- 2 Lower bucket bearing

- ▶ Move the lift arms and the bucket to the position shown above.
- ▶ Rapidly tilt the bucket in and out, and check the lower bucket bearings 2 for noise and play.

Replace the bearing bushings if:

- There is a lot of play with the bucket bearings
- Loud noise occurs



Note

To replace the bearing bushings:

- ▶ Contact Liebherr customer service.

5.16.3 Lubricating and testing the quick-change device

This equipment is optional.

Lubricating the quick-change device

Make sure that the following requirements are fulfilled:

- The machine is in maintenance position 1.
- The working attachment is disconnected for lubricating points near the bucket coupling, which are difficult to access.

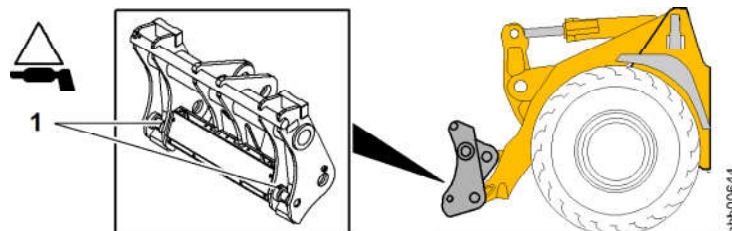

Fig. 369: Lubricating the quick-change device

- 1 Lubrication nipple
- ▶ Lubricate the grease nipple 1.

LBH/11340740/06/10-2013/en

CLICK HERE TO **DOWNLOAD** THE COMPLETE MANUAL

- Thank you very much for reading the preview of the manual.
- You can download the complete manual from: www.heydownloads.com by clicking the link below



- Please note: If there is no response to CLICKING the link, please download this PDF first and then click on it.

CLICK HERE TO **DOWNLOAD** THE COMPLETE MANUAL