

**en**

**Operator's manual**

Wheeled excavator

**Document ID**

	ORIGINAL OPERATOR'S MANUAL
<b>Order number:</b>	12203384
<b>Issued:</b>	2020-04-22
<b>Version:</b>	01
<b>Author:</b>	LHB / Technical Documentation Department

**Product ID**

<b>Manufacturer:</b>	Liebherr-Hydraulikbagger GmbH
<b>Type:</b>	A 912 Compact Litronic
<b>Type no.:</b>	1506
<b>From Serial no.:</b>	74759

**Contact**

Liebherr-Hydraulikbagger GmbH  
Liebherrstraße 12  
D – 88457 Kirchdorf/Iller

CLICK HERE TO **DOWNLOAD** THE COMPLETE MANUAL

- Thank you very much for reading the preview of the manual.
- You can download the complete manual from: [www.heydownloads.com](http://www.heydownloads.com) by clicking the link below



- Please note: If there is no response to CLICKING the link, please download this PDF first and then click on it.

CLICK HERE TO **DOWNLOAD** THE COMPLETE MANUAL

3.1.2	Control unit A	58
3.1.3	Control unit B	59
3.1.4	Control unit C	59
3.1.5	Further control units	60
3.1.6	Symbols on control description sticker	60
3.2	Display	68
3.2.1	Display	68
3.2.2	Status symbols	69
3.2.3	Start page menu	82
3.2.4	Camera menu	83
3.2.5	Automatic heating and automatic ventilation	84
3.2.6	Automatic air conditioning	88
3.2.7	Operating status menu	91
3.2.8	Exhaust system submenu	92
3.2.9	Sensor-controlled low idle automatic and automatic engine stop submenu (option)	93
3.2.10	System settings menu	94
3.2.11	Operating hour meter and odometer submenu	95
3.2.12	Windscreen wiper interval submenu	95
3.2.13	Radio remote control submenu	96
3.2.14	Display settings submenu	97
3.2.15	Display brightness and display volume submenu	97
3.2.16	Camera image contrast submenu	98
3.2.17	Camera return time submenu	98
3.2.18	Regional settings and system parameters submenu	99
3.2.19	Unit selection submenu	99
3.2.20	System diagnosis submenu	100
3.2.21	Time zone submenu	100
3.2.22	Time format and date format submenu	101
3.2.23	Language selection submenu	101
3.2.24	Electrical outputs submenu	102
3.2.25	Electrical inputs submenu	103
3.2.26	Function settings menu	103
3.2.27	Central lubrication system submenu (option)	105
3.2.28	Maintenance submenu	105

## 1.2 Technical data

### 1.2.1 Vibration emission

Designation	Unit	Value
Hand/arm vibrations	m/s <sup>2</sup>	≤ 2.5
Whole-body vibrations	m/s <sup>2</sup>	≤ 0.5

Tab. 1: Vibration emission

#### Operator's seat

- The operator's seat built into this machine by the manufacturer conforms to ISO 7096:2000, EM 6.

#### Hand/arm vibrations

- If the machine is operated as intended, the weighted (frequency-weighted) effective value of the hand/arm vibrations in accordance with ISO 5349- 1:2001 is less than 2.5 m/s<sup>2</sup>.

#### Whole-body vibrations

- This value conforms to the details of technical report ISO/TR 25398:2006.
- The measuring inaccuracy is defined in standard EN 12096:1997.
- As the specified values are individual effective values for specific typical application areas, only a limited assessment of the load imposed on the operator by whole-body vibrations is possible.

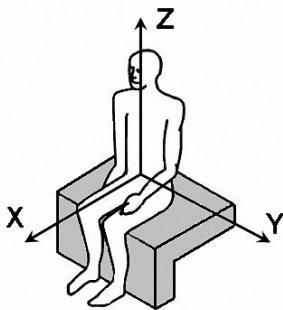

### 1.2.2 CO<sub>2</sub> emissions of diesel engine

#### NOTICE

Incorrect operation!  
High emission values.

- ▶ Operate and service diesel engine and exhaust treatment system according to operator's manual.

	mm
<b>A</b>	2,525
<b>B</b>	2,550
<b>B1</b>	2,550
<b>B2</b>	2,550
<b>B3</b>	2,550
<b>C</b>	3,150
<b>D</b>	1,675
<b>E</b>	1,675
<b>H</b>	2,575
<b>I1</b>	405
<b>I2</b>	420
<b>I3</b>	465
<b>I5</b>	420
<b>J1</b>	585
<b>J2</b>	625
<b>J3</b>	650
<b>J5</b>	625
<b>K</b>	1,210
<b>L</b>	2,540
<b>M</b>	1,100
<b>M1</b>	1,440
<b>Q</b>	340
<b>T1</b>	1,185
<b>T2</b>	1,105
<b>T3</b>	1,170
<b>T5</b>	1,120
<b>U2</b>	4,375
<b>U5</b>	4,850
<b>U7</b>	4,835

E = Tail radius  
Tyres 9.00-20

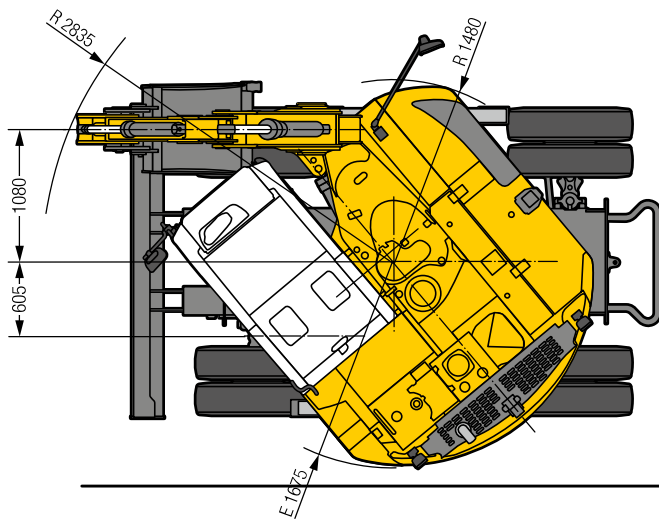

**Min. turning radius on tyres 9.00-20**  
Four wheel steering 4,29 m      Front wheel steering 6,55 m

Stick	Two-piece boom 4.25 m				
	Rear blade	Rear outriggers	Rear outriggers + front blade	Rear two-piece blade	Rear two-piece + front blade
	m	mm	mm	mm	mm
<b>V</b>	1.85	6,450	6,550	6,550	6,550
	2.05	6,150	6,250	6,250	6,200
<b>W</b>	1.85	2,550	2,550	2,550	2,550
	2.05	2,550	2,550	2,550	2,550
<b>X</b>	1.85	8,350	8,450	8,450	8,400
	2.05	8,350	8,450	8,450	8,450

Dimensions are with equipment over steering axle  
W = Max. ground clearance including approx. 150 mm piping

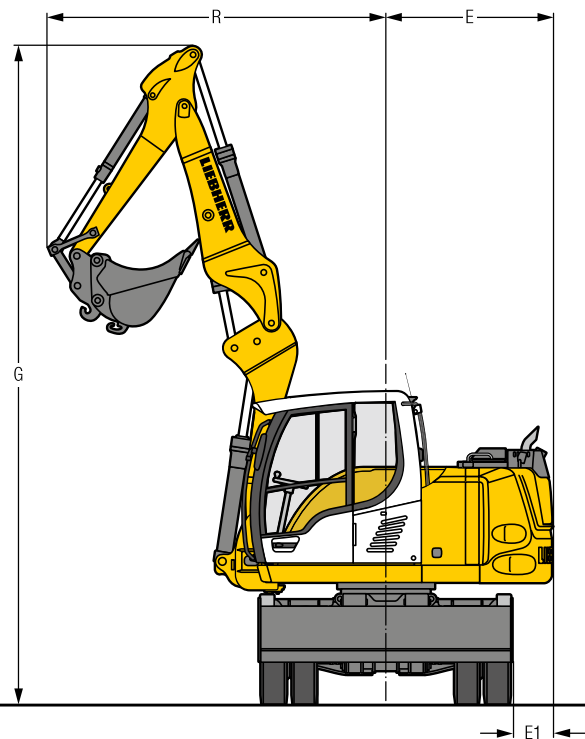

Boom	Stick m	G mm	R mm	E mm	E1 mm
<b>Two-piece boom</b>	1.85	6,620	3,210	1,675	405
<b>Two-piece boom</b>	2.05	6,620	3,305	1,675	405



## Operator's Cab

<b>Cab</b>	ROPS safety cab structure (roll-over protection system) with individual windscreens or featuring a slide-in subpart under the ceiling, work headlights integrated in the ceiling, a door with a sliding window (can be opened on both sides), large stowing and depositing possibilities, shock-absorbing suspension, sounddamping insulating, tinted laminated safety glass, separate window shades for the sunroof window and windscreen
<b>Operator's seat Standard</b>	air cushioned operator's seat with 3D-adjustable armrests, headrest, lap belt, seat heater, manual weight adjustment, adjustable seat cushion inclination and length and mechanical lumbar vertebrae support
<b>Operator's seat Comfort (Option)</b>	in addition to operator's seat standard: lockable horizontal suspension, automatic weight adjustment, adjustable suspension stiffness, pneumatic lumbar vertebrae support and passive seat climatisation with active coal
<b>Operator's seat Premium (Option)</b>	in addition to operator's seat comfort: active electronic weight adjustment (automatic re-adjustment), pneumatic low frequency suspension and active seat climatisation with active coal and ventilator
<b>Control system</b>	joysticks with arm consoles and swivel seat, folding left arm console
<b>Operation and displays</b>	large high-resolution operating unit, self-explanatory, colour display with touchscreen, video-compatible, numerous setting, control and monitoring options, e.g. air conditioning control, fuel consumption, machine and tool parameters
<b>Air-conditioning</b>	automatic air-conditioning including demisting (optional). Automatic heating and ventilation system (standard): fast de-icing at the press of a button, air vents can be operated via a menu; recirculated air and fresh air filters can be easily replaced and are accessible from the outside; designed for extreme outside temperatures, sensors for solar radiation, inside and outside temperatures



## Undercarriage

<b>Drive</b>	oversized two speed power shift transmission with additional creeper speed, Liebherr axial piston motor with functional brake valve on both sides
<b>Pulling force</b>	84 kN
<b>Travel speed</b>	0 – 3.5 km/h stepless (creeper speed off-road) 0 – 7.0 km/h stepless (off-road) 0 – 13.0 km/h stepless (creeper speed on-road) 0 – 20.0 km/h stepless (road travel) 0 – max. 25.0 or 30.0 km/h Speeder (Option)
<b>Driving operation</b>	automotive driving using accelerator pedal, cruise control function: storage of variable accelerator pedal positions, both off-road and on-road
<b>Axles</b>	manual or automatic hydraulically controlled front axle oscillation lock
<b>Option</b>	four wheel steering
<b>Service brake</b>	two circuit travel brake system with accumulator; wet and backlash-free disc brake
<b>Holding brake</b>	wet multi-disc (spring applied, pressure released)
<b>Stabilization</b>	stabilizing blade (adjustable during travel for dozing) 2 point outriggers stabilizing blade front + 2 point outriggers rear divided blade rear divided blade rear and stabilizing blade front



## Attachment

<b>Type</b>	high-strength steel plates at highly stressed points for the toughest requirements. Complex and stable mountings of attachment and cylinders
<b>Hydraulic cylinders</b>	Liebherr cylinders with special seal system as well as shock absorption
<b>Bearings</b>	sealed, low maintenance



## Complete Machine

<b>Lubrication</b>	
Option	Liebherr central lubrication system for upper-carriage and attachment, automatically

- Exclusively mount and use special working attachments with approval and as per stipulations of manufacturer of basic machine.

**Note**

- ▶ Any other use or use beyond the stated use is improper use.

### 2.2.3 Foreseeable misuse

Do not use machine in following cases:

- Transport of persons without mounted and functioning safety equipment
- Lifting of persons without mounted and functioning safety equipment
- Driving with attached load
- Work in explosive environment without corresponding and necessary equipment
- Work in contaminated environment without corresponding and necessary equipment
- Sweeping on side (with working attachment)
- Stamping
- Striking
- Lifting loads without suitable means
- Pulling and pushing of vehicles or objects without suitable towing attachments and brakes on machine

**Note**

- ▶ The manufacturer is not liable for damage caused by improper use.

### 2.2.4 Operating conditions

- Operate machine in an ambient temperature of -20 °C to 40 °C.
- In case of divergent ambient temperatures, contact Liebherr customer service.
- In case of deployments at below -10 °C, adhere to diesel fuel quality ([For more information see: 5.3.2 Diesel fuels, page 281](#)).
- In case of deployments at below -10 °C, use preheatings or arctic diesel (for more information on arctic diesel qualities, see table 1 and DIN EN 590).
- Adhere to operating temperatures of diesel fuels.

Permitted diesel fuels as per DIN EN 590	Cloud point	Ambient temperature
Standard winter diesel	-7 °C	To -10 °C
Arctic class 0	-10 °C	To -13 °C
Arctic class 1	-16 °C	To -20 °C

Tab. 7: Operating temperatures of diesel fuels

## Danger to life

### Operation during thunderstorms or storms

- If possible stop operation before a thunderstorm or storm.
- Put working attachment on the ground in flattest position possible.
- Secure machine correctly.
- Close window.
- Shut off diesel engine.
- Set ignition key to 0.

Sign	Description
	<p><b>Service brake and parking brake</b>                      Valid for wheeled excavators and handling machines with wheeled undercarriage.                      Do not apply service brake and parking brake at the same time when machine is in operation.                      Before leaving machine, block exclusively with parking brake.</p>
	<p><b>Operator's manual</b>                      Read accident prevention instructions in operator's manual.</p>
	<p><b>Accident prevention</b>                      Applies to machines with safety lever.                      Before leaving operator's seat pull up safety lever.                      Working attachment reaches as far as the operator's cab.                      Be careful when working attachment is retracted.</p>
	<p><b>Accident prevention</b>                      Applies to machines with folding console.                      Move folding console up before leaving operator's seat.                      Working attachment reaches as far as the operator's cab.                      Be careful when working attachment is retracted.</p>

LHB/12203384/01/2020-04-22/en

## 2.6.4 Emergency stop function of machine

### Damage to diesel engine

#### Incorrect use of emergency stop equipment

- Exclusively use emergency stop equipment if there is immediate danger.
- If emergency stop equipment has been activated: Let diesel engine run in idle mode for a few minutes after next start.

## 2.7 Safe operation

### 2.7.1 Intoxicants

#### Danger to life

#### Physical and mental impairment

- Make sure that no persons working on or with the machine are under the influence of drugs.
- Make sure that no persons working on or with the machine are under the influence of alcohol.
- Make sure that no persons working on or with the machine are under the influence of medication.
- Make sure that no persons working on or with the machine are overtired.
- Make sure that no persons working on or with the machine are exhausted.

### 2.7.2 Dangerous fuels and operating fluids

#### Injury

#### Incorrect handling

- Adhere to safety instructions on handling oils, greases and chemical substances.
- In case of hot lubricants and fuels put on personal protective equipment.

#### Environmental damage

#### Incorrect disposal

- Dispose of lubricants and fuels safely and in eco-friendly manner.
- Adhere to guidelines applicable to disposal.

# 3 Control and operation

## 3.1 Control and operating elements

### 3.1.1 Overview of operator's platform

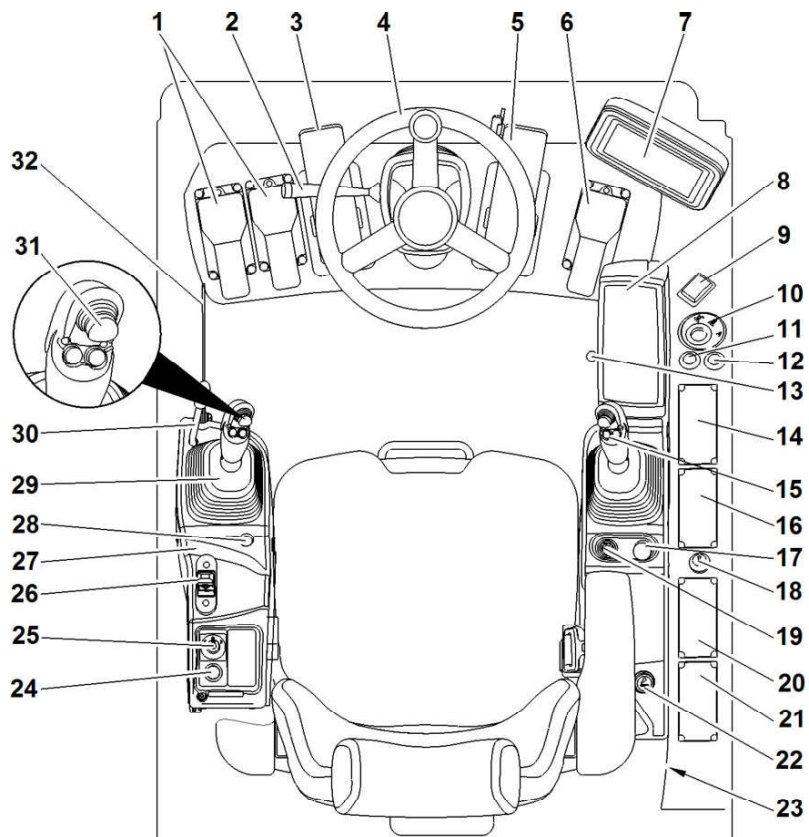











Fig. 56: Operator's platform

- |    |                                    |    |                                   |
|----|------------------------------------|----|-----------------------------------|
| 1  | Double pedal for options           | 17 | Engine speed controller           |
| 2  | Horn, turn signal                  | 18 | Confirmation button               |
| 3  | Positioning slewing brake (option) | 19 | Starting switch                   |
| 4  | Steering wheel                     | 20 | Control unit D                    |
| 5  | Service brake                      | 21 | Control unit E                    |
| 6  | Accelerator pedal                  | 22 | Cigarette lighter                 |
| 7  | Display                            | 23 | Socket (12 V)                     |
| 8  | Control unit A                     | 24 | Mirror heater button (option)     |
| 9  | No function assigned               | 25 | Mirror adjuster joystick (option) |
| 10 | Oscillating axle switch            | 26 | Adjusting leversupport (option)   |
| 11 | No function assigned               | 27 | Folding console                   |

*See next page for continuation of the image legend*

## Crawler excavator travel mode

Symbol	Description	Symbol	Description
	Extending side frames		Travelling left
	Retracting side frames		Travelling right
	Travelling forward		Turning travel gear left on the spot
	Travelling forward and backward		Turning travel gear right on the spot
	Travelling backwards		

Tab. 18: Crawler excavator travel mode

## Rail excavator travel mode

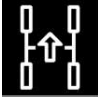
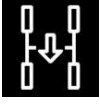









Symbol	Description	Symbol	Description
	Travelling forward		Travelling backwards

Tab. 19: Rail excavator travel mode

Symbol	Meaning
	Backward Stability; shut-off initiated

Tab. 24: Status symbols of slewing gear

## Height-adjustable cab

Symbol	Meaning
	Adjusting operator's cab blocked
	Lifting operator's cab blocked
	Lowering operator's cab blocked
	Automatic mode for upper park position
	Automatic mode for lower park position
	Operator's cab; neutral position required
	Boom line break safety open
	Hoist cylinder protection switched off
	Stick cylinder protection switched off
	Inclination cylinder protection switched off
	Adjusting cab inclination blocked

## Operation using control unit

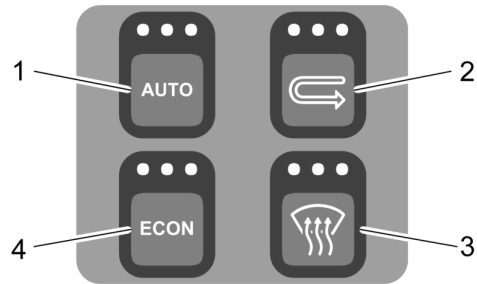

Fig. 384: Keys on control unit

- |   |                      |   |                      |
|---|----------------------|---|----------------------|
| 1 | Automatic mode key   | 3 | Defrosting key       |
| 2 | Recirculated air key | 4 | No function assigned |

When function is switched on, all LEDs on corresponding key light up.

- ▶ Switch on or switch off functions: Press *automatic mode key 1*, *recirculated air key 2* or *defrosting key 3*.

## Automatic heating and automatic ventilation in emergency mode

Malfunctions in the air conditioning control have the following results:

- Functions are not displayed.
- Temperature display is replaced with a bar chart display.
- Error messages are shown on the display.

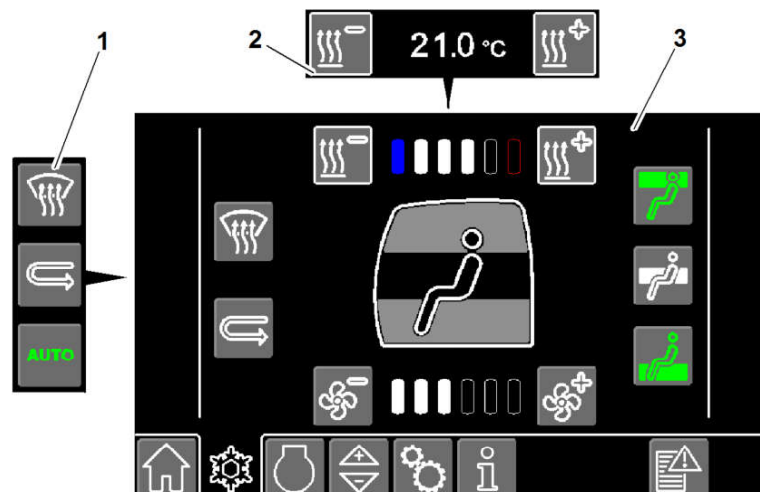





Fig. 385: Air conditioning menu in emergency mode

- |   |                                    |   |   |
|---|------------------------------------|---|---|
| 1 | Buttons in normal mode             | 3 | Air conditioning menu in emergency mode |
| 2 | Temperature display in normal mode |   |   |

- ▶ Take note of error messages.

### 3.2.14 Display settings submenu

Menu call:  > 

Menu button	Designation
	Return time (For more information see: 3.2.17 Camera return time submenu, page 98)
	Camera image contrast, side area camera (For more information see: 3.2.16 Camera image contrast submenu, page 98)
	Camera image contrast, rear area camera (For more information see: 3.2.16 Camera image contrast submenu, page 98)
	Display brightness and display volume (For more information see: 3.2.15 Display brightness and display volume submenu, page 97)

Tab. 37: Menu buttons

### 3.2.15 Display brightness and display volume submenu

Menu call:  >  > 

The display of this submenu varies depending on machine configuration:

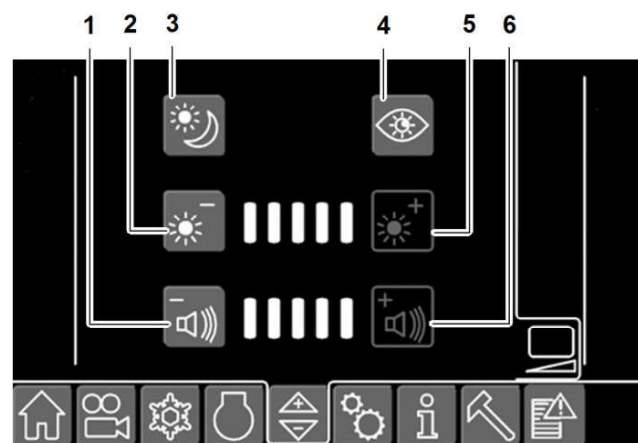

Fig. 417: Display brightness and display volume submenu

- |                                      |  |
|--------------------------------------|--|
| 1 Reducing display volume button     | 4 Night Shift mode button              |
| 2 Reducing display brightness button | 5 Increasing display brightness button |
| 3 Day/night mode button              | 6 Increasing display volume button     |

- ▷ Liebherr customer service has write access to machine control parameters.

## Deactivating write access

Liebherr customer service deactivates write access.

## Read access

Read access is always possible for Liebherr customer service. It is not necessary that the operator enables the online connection.

### 3.2.29 SF submenu

Menu call:  > 

### Quick-selection button submenu

Menu call:  >  > 

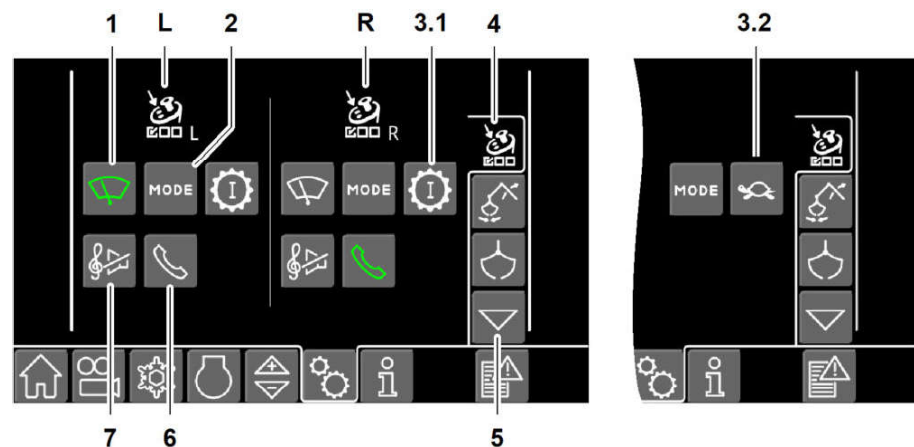

Fig. 453: Quick-selection button submenu

- |     |  |     |                                    |
|-----|--|-----|------------------------------------|
| 1   | Windscreen wiper button  | 4   | Quick-selection button menu button |
| L   | Left quick-selection button symbol   | 3.2 | Creeper gear button <sup>7)</sup>  |
| 2   | MODE button (Sensitive, ECO, Power, Power-Plus) (For more information see: 3.4.10 Engine speed and operating mode, page 155) | 5   | Scroll button                      |
| R   | Right quick-selection button symbol  | 6   | Telephone button                   |
| 3.1 | Gear step button <sup>6)</sup>   | 7   | Radio muting button                |

<sup>7)</sup> Applies to machines with travel gear

<sup>6)</sup> Applies to machines with transmission

## 3.3 Control

### 3.3.1 Battery main switch

Position of battery main switch is described in “access points” section. (For more information see: 5.4.1 Access points on uppercarriage, page 291)

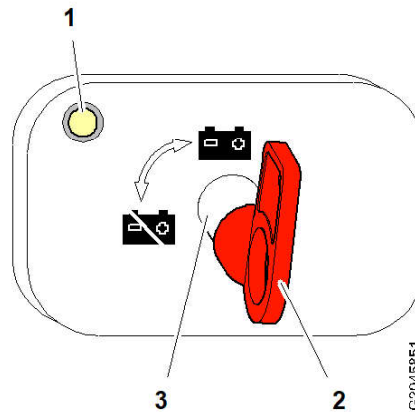

Fig. 487: Battery main switch

- 1 Indicator light<sup>16)</sup>
- 2 Battery main switch key
- 3 Battery main switch

Symbol	Function
	OFF
	ON

Tab. 42: Battery main switch

### Switching on battery main switch

- ▶ Turn battery main switch 3 to ON .
  - ▷ Machine's electrical system is supplied with voltage.

### Switching off battery main switch

#### Switching off battery main switch on machines without SCR system

Make sure the following preconditions are met:

- Auxiliary heater (option) is deactivated.

<sup>16)</sup> For machines with SCR system

## Adjusting seat height and adapting operator's seat to body weight

### Adjusting operator's seat manually

#### Standard seat

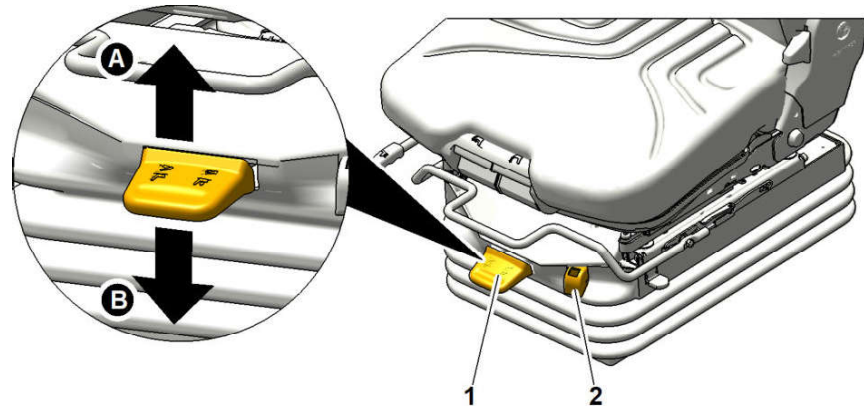

Fig. 507: Standard seat

A Increase

B Reduce

1 Adjustment lever

2 Display

► Sit on operator's seat.

► Adjust with adjustment lever 1 until display 2 is green.

#### Mechanically adjustable operator's seat (option)

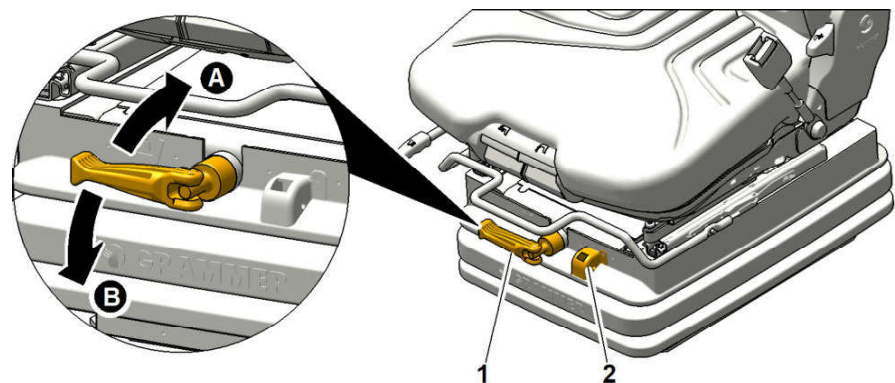

Fig. 508: Mechanically adjustable operator's seat

A Increase

B Reduce

1 Adjustment lever

2 Display

► Sit on operator's seat.

► Adjust with adjustment lever 1 until display 2 is green.

## Roof glass panel sun blind

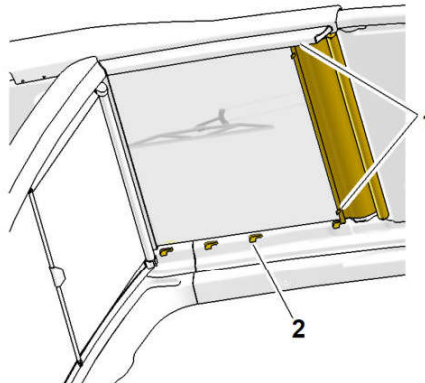

Fig. 534: Roof glass panel sun blind

1 Handle

2 Notch

## Sun visor (option)

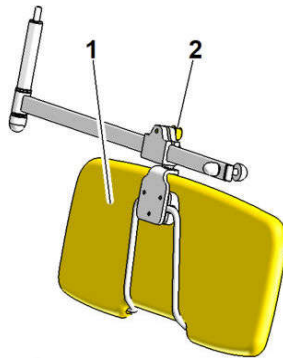

Fig. 535: Sun visor

1 Sun visor

2 Knurled screw

### 3.3.14 Viewing devices



#### **DANGER**

Incorrectly adjusted mirrors!  
Danger to life.

► Before starting work and starting driving, check field of vision of mirrors.

If mirrors collide with an obstacle:

► Check adjustment of mirrors.



#### **DANGER**

Defective viewing devices!  
Danger to life.

► Replace defective viewing devices.

LiDAT means that all important machine data can be viewed at any time. Depending on the subscription, data is updated several times a day and can be called up at any time using a web browser. It is also possible to call up particularly important information such as when the machine exits a predefined zone, or messages relating to certain operating statuses and application parameters.

- ▶ Assume last active operating mode: Press *MODE* key.
- or
- Select operating mode S, E and P: Press *MODE* key until required operating mode is active.
- or
- Select operating mode P+: Turn engine speed controller.

### 3.4.11 After starting

#### Operating machine



##### **DANGER**

Exhaust gases!  
Danger to life.

- ▶ Exclusively run diesel engine in enclosed rooms if there is adequate ventilation.
- ▶ Ensure sufficient fresh air supply.



##### **DANGER**

Sluggish control!  
Danger to life.

- ▶ Before putting load on machine, bring diesel engine and hydraulic oil to operating temperature.
- ▶ Carefully move machine to open ground.
- ▶ Before starting work, check all safety relevant functions.

During operation, check following points:

- Oil pressure is constant.
- Output and speed are constant.
- Exhaust gas is colourless.
- Coolant temperature is constant.
- Diesel engine sounds are normal.
- ▶ Plan a warm-up phase.
- ▶ Plan work so that the diesel engine can run at operating temperature for as long a period as possible.
- ▶ Monitor diesel engine during operation.
- ▶ Adhere to error messages and status symbols on the display.

If malfunctions occur in diesel engine:

- ▶ Shut off diesel engine immediately.

CLICK HERE TO **DOWNLOAD** THE COMPLETE MANUAL

- Thank you very much for reading the preview of the manual.
- You can download the complete manual from: [www.heydownloads.com](http://www.heydownloads.com) by clicking the link below



- Please note: If there is no response to CLICKING the link, please download this PDF first and then click on it.

CLICK HERE TO **DOWNLOAD** THE COMPLETE MANUAL

**Note**



Not licensed for public roads!

- ▶ On public roads, steer exclusively with steering wheel.

## Switching on and switching off joystick steering

Make sure the following preconditions are met:

- Ignition key is set to 1.
- Machine is stationary.
- Joysticks are in neutral position.

Button	Status of LEDs	Symbol on the display	Function
	<ul style="list-style-type: none"> <li>○</li> <li>○</li> <li>○</li> </ul>		Joystick steering switched off: Machine is exclusively steerable with steering wheel.
	<ul style="list-style-type: none"> <li>●</li> <li>●</li> <li>●</li> </ul>		Joystick steering switched on: Machine is steerable with right mini-joystick.

Tab. 57: Function of joystick steering key

If there is an error in the control system:

- ▶ Make sure that machine is stationary.
- ▶ Do not move joysticks.
- ▶ Move folding console up and then down again.

### 3.4.20 Four wheel steering (option)

**DANGER**

Unexpected steering behaviour!  
Danger to life.

- ▶ Check preselected steering type when starting machine.
- ▶ Check whether four wheel steering is activated or deactivated.
- ▶ Activate or deactivate steering reversal as required.

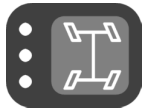
Key	Status of LEDs	Function
	<ul style="list-style-type: none"> <li>○</li> <li>○</li> <li>○</li> </ul>	Four wheel steering deactivated: Exclusively wheels on front axle are steered. Rear axle wheels remain rigid.
	<ul style="list-style-type: none"> <li>●</li> <li>●</li> <li>●</li> </ul>	Four wheel steering activated: Wheels on front axle and rear axle turn in respective opposite directions.

Tab. 58: Function of the four wheel steering key

## Double pedals

Function	Operation
Lower two-piece boom.	Press double pedal 1.
Raise two-piece boom.	Press double pedal 2.

Tab. 66: Double pedals

### 3.4.26 Turning and braking uppercarriage

#### Turning uppercarriage

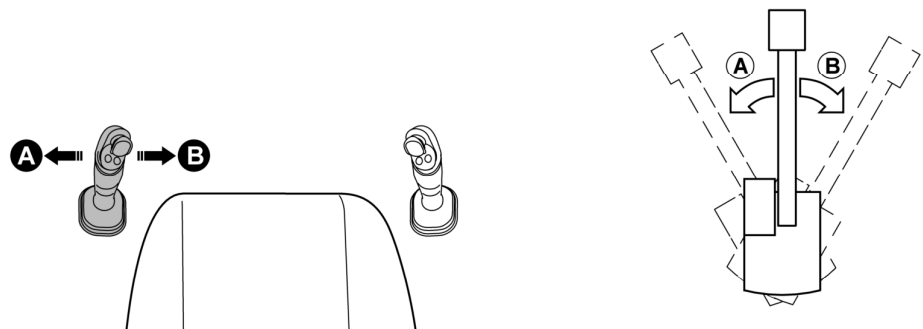

Fig. 666: Turning uppercarriage

Make sure the following preconditions are met:

- Slewing brake is released.
- ▶ Move joystick in direction **A**.
  - ▷ Uppercarriage turns to the left.
- ▶ Move joystick in direction **B**.
  - ▷ Uppercarriage turns to the right.

#### Braking uppercarriage

- ▶ Release joystick.
  - ▷ Uppercarriage is braked hydraulically.
- ▶ Move joystick in opposite direction.
  - ▷ Uppercarriage is braked hydraulically to maximum extent.

### 3.4.33 Using working tool in continuous mode (option)

#### Prerequisites for continuous mode

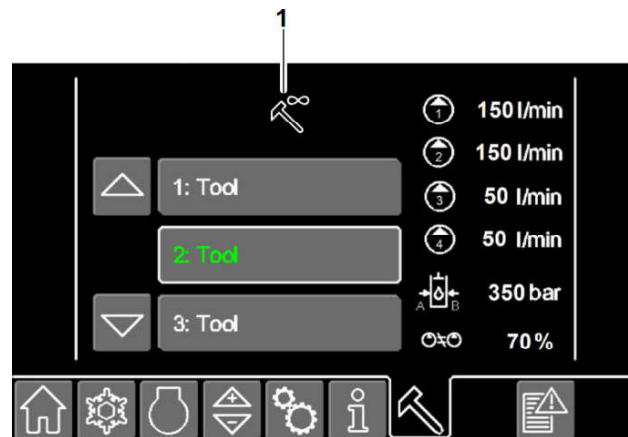

Fig. 693: Tool Control menu

- 1 Continuous operation for working tool symbol

Make sure the following preconditions are met:

- Diesel engine is running.
- Folding console is down.
- Servo control is switched on.
- Working tool is suitable for continuous mode.
- Working tool is selected in *Tool Control* menu.

#### Preselecting continuous mode



- ▶ Press *continuous mode* key.
- ▶ Press confirmation button.
  - ▷ LEDs in *continuous operation* key light up.
  - ▷ *Continuous mode* status symbol appears:



If *request denied* status symbol appears on the display:

- ▶ Make sure that all preconditions are met.
- ▶ Preselect continuous mode again.



#### Switching on continuous mode





##### Note

Different machine configuration!

- ▶ Adhere to control description sticker in operator's cab.

Key	Meaning
	Hoist cylinder shut-off is switched on
	It is possible to move the boom between the shut-off points.
	It is exclusively possible to set new shut-off points within the permitted working range.
	It is possible to bypass the shut-off points for 10 seconds.
	Hoist cylinder shut-off is switched off
	It is possible to set new shut-off points without restrictions.
	It is possible to move the boom without restrictions.
	Button is black. Teaching in shut-off point function is not available.

Tab. 73: Keys

Status symbol	Meaning
	Shortly before the shut-off point is reached, the speed of the boom movement is reduced automatically.
	When a shut-off point is reached, the boom movement stops.
	When a shut-off point is reached, it is exclusively possible to move the boom to the other shut-off point.
	Hoist cylinder shut-off is bypassed.
	It is possible to move the boom without restrictions.

Tab. 74: Status symbols

**CAUTION**

Unexpected settings!  
Danger to life.

- ▶ Inform all operators of machine about changes.
- ▶ Set shut-off points again after every working tool change.

**Switching on hoist cylinder shut-off**

- ▶ Press *function settings* menu button.
- ▶ *Hoist cylinder shut-off* menu button.
- ▶ Press *hoist cylinder shut-off* button 1.
  - ▷ *Confirmation required* status symbol appears on the display:



- ▶ Press confirmation button within 5 seconds.
  - ▷ *Hoist cylinder shut-off* button lights up green:



**Note**

Moving contour stops the movement of working attachment!

- ▶ Enable stick movement: Lower working attachment.

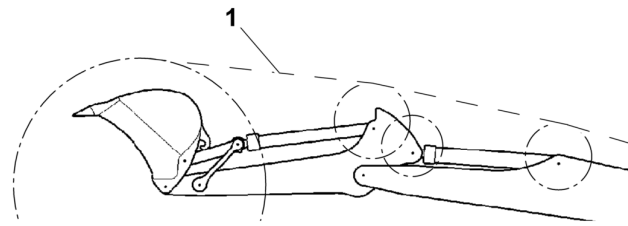

Fig. 774: Moving contour

**1** Moving contour

The moving contour considers the arrangement of the working attachment:

- Hydraulic lines
- Electrical cables
- Hydraulic cylinders
- Line break safeties
- Movement radii of working attachment
- Movement radius 1.75 m of largest Liebherr bucket



**Note**

If change to movement radius is necessary:

- ▶ Contact Liebherr customer service.

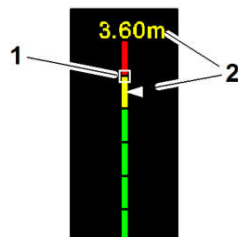

Fig. 775: Scale in height limitation menu

**1** Set limit value

**2** Current height of working attachment

Scale	Status symbol	Meaning
Font colour of current height of working attachment <b>2</b> is green. Arrow is in green area of scale.		Working attachment is moving in safe area.
Font colour of current height of working attachment <b>2</b> is yellow. Arrow is in yellow area of scale.		Working attachment is moving close to set limit value. Speed of movement of working attachment is reduced.

LHB/12203384/01/2020-04-22/en

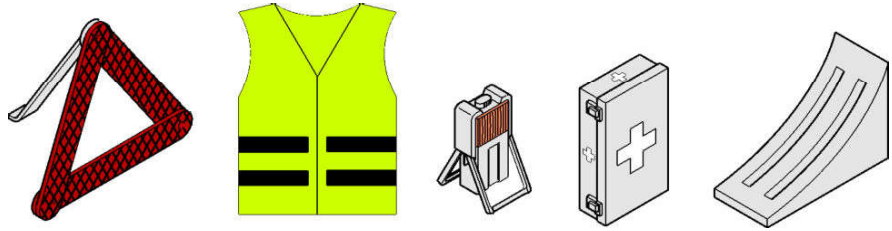

Fig. 788: Examples of obligatory items

- ▶ Before driving on public roads, check obligatory items for completeness.

## Preparing machine for on-road travel

### Measures to be taken on the machine

- ▶ Free machine from coarse dirt.
- ▶ Clean tyre profiles.
- ▶ Empty working tool.
- ▶ Close doors and trim covers.
- ▶ Check the road lighting function.
- ▶ Check adjustment of viewing devices. (For more information see: [3.3.14 Viewing devices, page 137](#))

### Turning uppercarriage to travel position

- ▶ Turn operator's cab towards oscillating axle.
- ▶ Align uppercarriage parallel to undercarriage.
  - ▷ *Travel position* status symbol appears on the display:



### Positioning working attachment

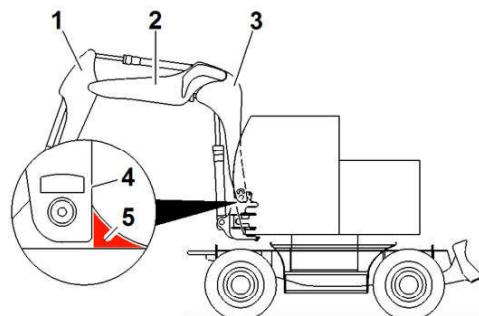

Fig. 790: Positioning working attachment

- |   |            |   |                          |
|---|------------|---|--------------------------|
| 1 | Stick      | 4 | Outer edge of basic boom |
| 2 | Boom       | 5 | Marking                  |
| 3 | Basic boom |   |                          |

- ▶ Move basic boom 3 until outer edge of basic boom 4 touches marking 5.

- ▶ Exclusively raise and lower loads vertically.
- ▶ Move loads close to the ground.

### 3.6.12 Lifting loads with quick coupler

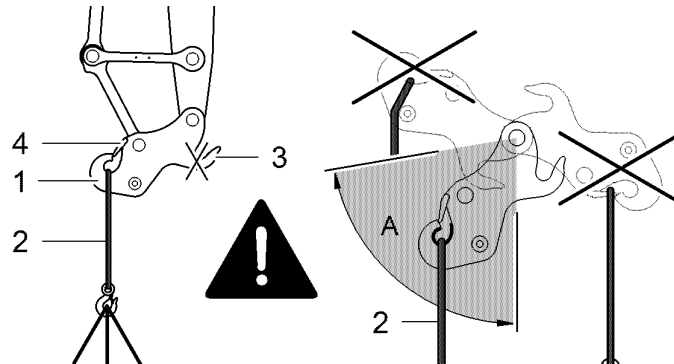

Fig. 802: Lifting loads with quick coupler

- |   |                               |   |                         |
|---|-------------------------------|---|-------------------------|
| 1 | Load hook                     | 4 | Safety flap             |
| 2 | Lifting accessory             | A | Permitted slewing range |
| 3 | Pick-up hook for working tool |   |                         |

The quick coupler has two load lift hooks **1** for load-lifting work.

The maximum load capacity value of each load lift hook **1** is specified on the quick coupler.

### Preparing load-lifting work

- ▶ Remove working tool from quick coupler and secure it.
- ▶ Fully retract locking pin.
- ▶ Align opening of the load lift hooks **1** upward.
- ▶ Check function of the safety flaps **4**.

### Lifting loads



#### **DANGER**

Machine tipping over or falling loads!  
Danger to life.

- ▶ Make sure that no-one is in danger zone.
  - ▶ Have load-lifting work carried out exclusively by trained personnel.
  - ▶ Exclusively move quick coupler within the permitted slewing range **A**.
- 
- ▶ Exclusively attach loads to load lift hooks **1**.
  - ▶ Do not put load on safety flaps **4**.
  - ▶ Observe maximum load lift of the load lift hooks **1**.
  - ▶ Observe load lift chart in the operator's cab.
  - ▶ Lift loads safely. (For more information see: 3.6.11 Lifting loads, page 226)

### 3.9.4 Tying down the machine

The operator's cab contains a sign with machine-specific tying specifications.

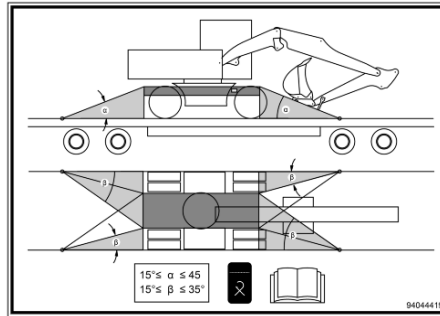

Fig. 814: Sign (example) in the operator's cab

















#### **DANGER**

Machine slipping!  
Danger to life.

- ▶ Secure machine adequately against slipping.
- ▶ Exclusively use suitable cables and chains.



- ▶ Tie machine with cables and chains at indicated points in line with machine-specific tying specifications.

Symbol	Meaning	Effect, characteristic	Remedy
	Prewarning: Fuel pressure in Common Rail system is high or low.	Diesel engine is running unevenly. Diesel engine output is reduced automatically.	Shut off diesel engine. Have fuel filter cleaned by authorized specialist personnel or replaced if necessary; If symbol does not disappear: Contact Liebherr customer service.
	Fuel pressure in Common Rail system is too high or too low.		
	Prewarning: Fuel temperature is high.	Diesel engine output is reduced automatically. Diesel engine is damaged.	Shut off diesel engine. Clean fuel cooler. If symbol is still displayed: Contact Liebherr customer service.
	Fuel temperature is too high.		
	Prewarning: Coolant level is low.	Diesel engine is damaged.	Shut off diesel engine. Fill with coolant. If symbol is still displayed: Contact Liebherr customer service.
	Coolant level is too low.		
	Prewarning: Coolant temperature is high.	Diesel engine output is reduced automatically. Diesel engine is damaged.	Shut off diesel engine. Reduce load. Fill with coolant. Clean engine cooler. If symbol is still displayed: Contact Liebherr customer service.
	Coolant temperature is too high.		
	Prewarning: Air filter is contaminated. Dust collecting tank is full.	Diesel engine output is reduced automatically. Diesel engine is damaged.	Shut off diesel engine. Empty dust collecting tank. Replace air filter.
	Air filter is contaminated. Dust collecting tank is full.		
	Prewarning: Charge air temperature is high.	Diesel engine output is reduced automatically. Diesel engine is damaged.	Shut off diesel engine. Clean intercooling air circuit. If symbol is still displayed: Contact Liebherr customer service.
	Charge air temperature is too high.		
	Prewarning: Diesel engine speed is high.	Diesel engine is damaged.	Shut off diesel engine. Contact Liebherr customer service.
	Diesel engine speed is too high.		

Malfunction / error	Cause	Remedy
Working attachment cannot be moved.	Limitation of working attachment has been initiated.	Bypass limitation. (For more information see: 3.5 Shut-off functions, page 193)
	Angle sensors of working attachment are defective.	Switch off limitation or shut-off (For more information see: 3.5 Shut-off functions, page 193) . Contact Liebherr customer service.
Working tool cannot be used.	Function is not switched on.	Switch on function.
	Hydraulic lines are not connected.	Connect hydraulic lines.

Fuse	Consumer	Rating [A]
F2_1	K2_1, travel light left	10
F2_2	K2_2, beacon	10
F2_3	LiDAT, data interface option	5
F3_1	Reversing camera, side camera	10
F3_2	Not used	
F3_3	Door strap system, height adjustable cab	15
F4	Cigarette lighter	10
F5	Interior lighting triggered by door contact	5
F6	Interior lighting, mirror heater	5
F7	Option circuit board power supply	10
F8	Condenser fan	30
F9	K02, front roof light	30
F10	K07, rear window wiper	10
F11	K08, terminal 58	15
F12	K03, rear roof light	15 , 30
F14	Air-sprung operator's seat	10
F15	Terminal 15 air conditioning control	15
F16	Control unit A	15
F17	S7 safety lever or folding console	10
F18	Not used	15
F19	+24V input sensor for input modules FAP, A163, A164, A165	10
F20	Input logic for input modules FAP power supply	5
F21	Display, data interface J1939	5
F22	Terminal 15, master power supply	10
F23	A169, control unit	10
F24	A170, control unit	10
F25	A171, control unit, Tool Management	10
F26	A172, control unit	10
F27	Terminal 30, master power supply	10
F28	Not used	10
F29	Not used	10
F30	Starting switch	10
F31	Terminal 30 air conditioning control	20
F32	K05, roof wiper	10
F33	K04, windscreen wiper top	10
F34	K06, windscreen wiper bottom	10
F35	K09, Tool Management, voltage transformer, radio	15

Tab. 85: Main circuit board A161

### 5.2.2 Lubrication chart

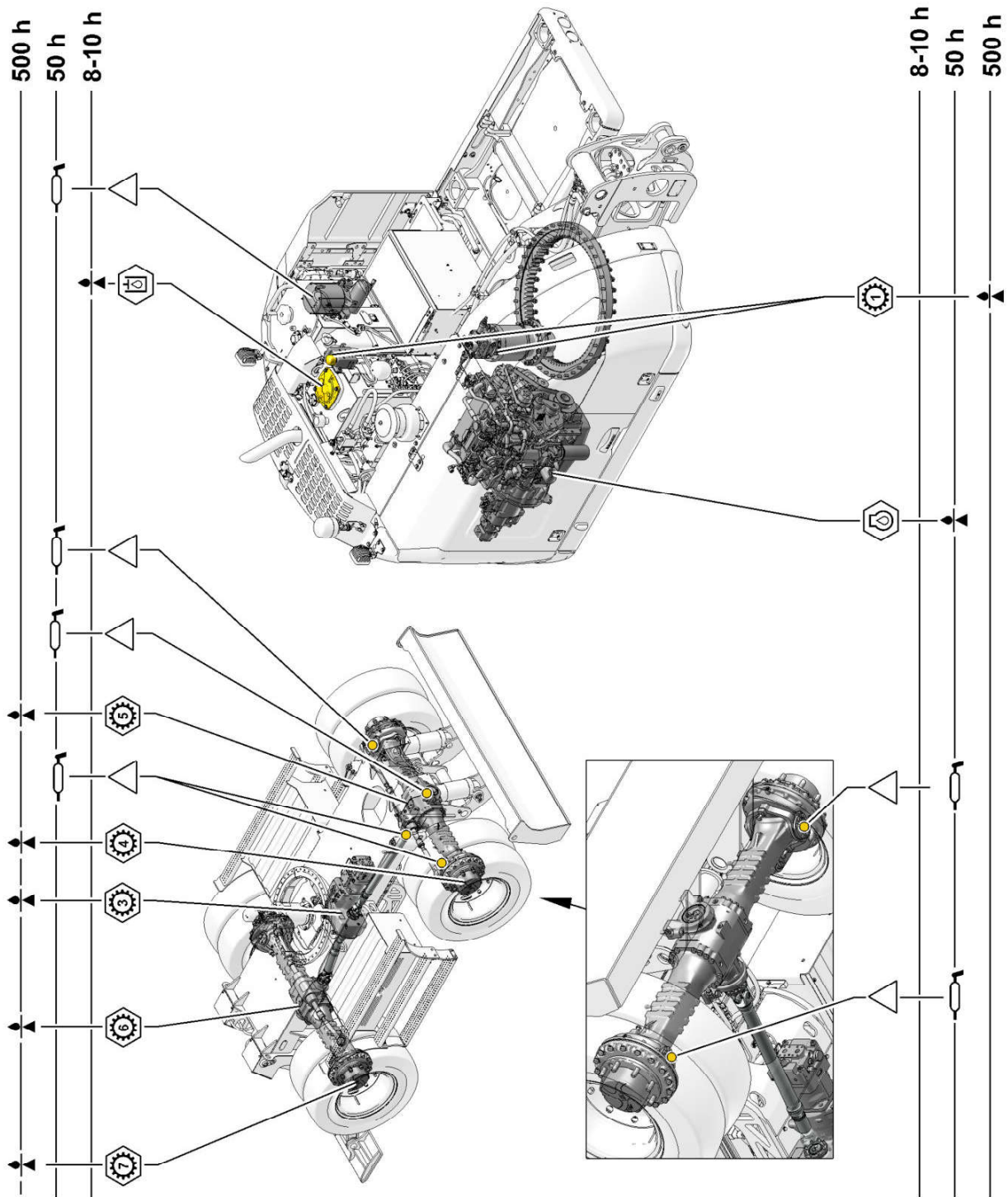

Fig. 899: Lubrication chart for uppercarriage and undercarriage

LHB/12203384/01/2020-04-22/en

		Dust intensive application	Normal operation
Eco-friendly application (oil analysis mandatory)	<b>Liebherr-PAO biodegradable</b>	Upon handover, then every 250 h, at least once a year	Upon handover, then every 1000 h, at least once a year
	Liebherr Hydraulic Plus		
	Liebherr Hydraulic Plus Arctic		

Tab. 112: Oil analysis

## Filter replacement

	Dust intensive application	Normal operation
Liebherr return filter	Every 250 h, also during every hydraulic oil change	Once after 500 h, then every 1000 h, also during every hydraulic oil change
Liebherr breather filter	Every 500 h, also during every hydraulic oil change	Every 2000 h, also during every hydraulic oil change
Liebherr bypass filter (option) <sup>25)</sup>	If necessary, every 2000 h	
Liebherr bypass filter (option) integrated in return <sup>25)</sup>	If necessary, every 2000 h	

Tab. 113: Filter replacement

## Oil change

	Without oil analysis	With oil analysis <sup>26)</sup>
<b>Liebherr mineral oil</b>	Every 3000 h	Every 6000 h
Liebherr Hydraulic Basic 68		
Liebherr Hydraulic Basic 100		
Liebherr Hydraulic HVI		
<b>Liebherr-PAO biodegradable</b>	Every 4000 h <sup>27)</sup>	Every 10000 h
Liebherr Hydraulic Plus		
Liebherr Hydraulic Plus Arctic		

Tab. 114: Oil change

<sup>25)</sup> A bypass filter is mandatory for eco-friendly application.

<sup>26)</sup> Change oil after negative oil analysis.

<sup>27)</sup> Oil analysis is mandatory for eco-friendly application.

## 5.6 General maintenance

### 5.6.1 Welding

- ▶ For procedure on repair welding, refer to service manual under Chapter 140.
- ▶ Document repair case in repair report, refer to service manual under Chapter 140.
- ▶ Only have repair welding performed by certified specialist welding operation.

### 5.6.2 Corrosion-proofing piston rods

Corrosion-proofing piston rods prevents corrosion.



#### Note

Liebherr recommends:

- ▶ Use Liebherr Chrome Protect.

#### NOTICE

Corrosion!

Damage to piston rods.

- ▶ Check corrosion-proofing daily.
- ▶ Where necessary, apply corrosion inhibitor.



#### Note

Corrosion in maritime areas or corrosive environments!

- ▶ When in storage, use acid-free corrosion inhibitor grease as corrosion inhibitor.
- ▶ For non-moved piston rods, use acid-free corrosion inhibitor grease as corrosion inhibitor.
- ▶ Remove grease before retracting the piston rods.
- ▶ For moved piston rods, use Liebherr Chrome Protect as the corrosion inhibitor.
- ▶ Replace corrosion inhibitor at susceptible areas after each cleaning.

### Machine in operation

- ▶ Fully retract all piston rods every day.
  - ▷ Piston rods are covered with a protective film of hydraulic oil.

If it is not possible to retract piston rods fully into cylinders:

- ▶ Apply corrosion inhibitor to exposed areas of piston rods.

If hydraulic cylinder is not moved for a long time:

- ▶ Apply corrosion inhibitor to exposed areas of piston rods.
- ▶ Check corrosion protection on little-moving hydraulic cylinders every day.

### Parking or transporting machine

- ▶ Retract piston rods fully into cylinders.

### 5.7.3 Checking components for cracks

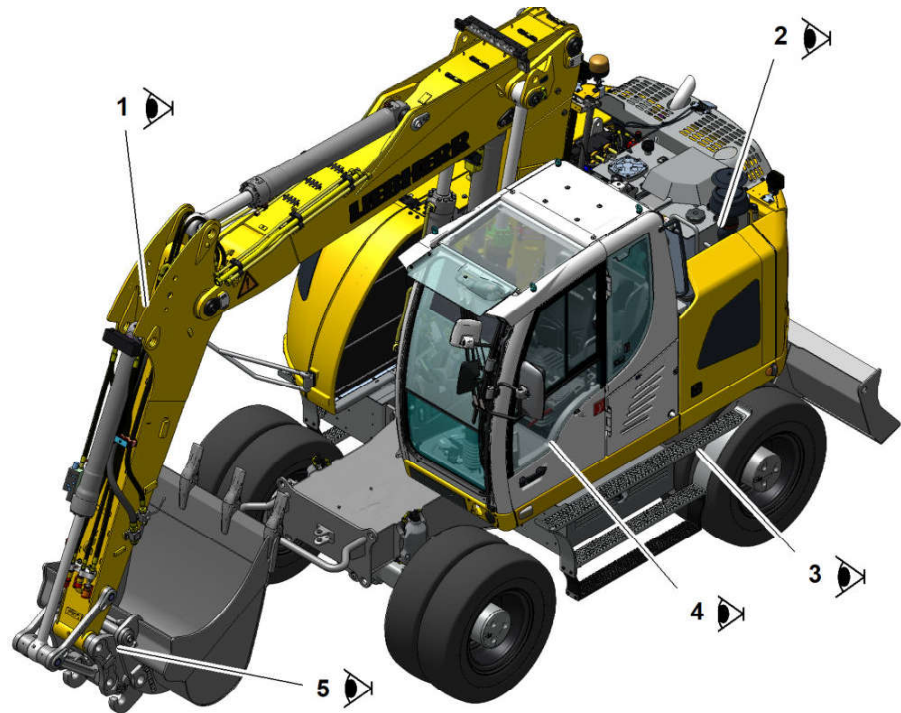

Fig. 919: Checking components for cracks

### Visual inspection during maintenance tasks

#### NOTICE

Incorrect check!  
Damage to machine.

► Perform visual inspections as per maintenance and inspection schedule.

Position	Assembly	Visual inspection for defects
1	Steel frame of working attachment	Check bearing points, supports, holders, fastening elements, connections for damage, warping and cracks.
2	Steel frame of uppercarriage	
3	Steel frame of undercarriage	
4	Steel frame of operator's cab	
5	Steel frame of quick coupler and working tool	

Tab. 131: Visual inspection for defects

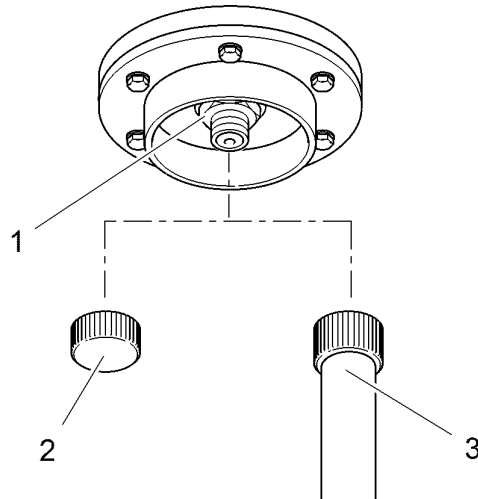

Fig. 927: Fuel tank: Draining water and sediments

- |                         |                     |
|-------------------------|---------------------|
| <b>1</b> Drain valve    | <b>3</b> Drain hose |
| <b>2</b> Protective cap |                     |

Access to drain valve in fuel tank is under uppercarriage.

- ▶ Place receptacle under drain valve **1**.
- ▶ Remove protective cap **2** from drain valve **1**.
- ▶ Hold free end of drain hose **3** into receptacle.
- ▶ Screw drain hose **3** onto drain valve **1** until liquid emerges.
  - ▷ Drain valve **1** is open.
  - ▷ Water and sediment flow out of fuel tank.

When fuel emerges without water or sediment:

- ▶ Remove drain hose **3**.
- ▶ Screw protective cap **2** onto drain valve **1**.
- ▶ Dispose of water and sediment in eco-friendly manner.

Make sure following requirements are fulfilled:

- Diesel engine is shut off.
- Diesel engine has cooled down.
- ▶ Loosen nut on radiator fan **3**.
- ▶ Move radiator fan **3** to the side.
- ▶ Check combination cooling unit **1** and radiator fan **3** for contamination and clean if necessary.
- ▶ Clean cooling fins with compressed air.
- ▶ Clean radiator fan **3** with compressed air.
- ▶ Move radiator fan **3** back.
- ▶ Tighten nut on radiator fan **3**.

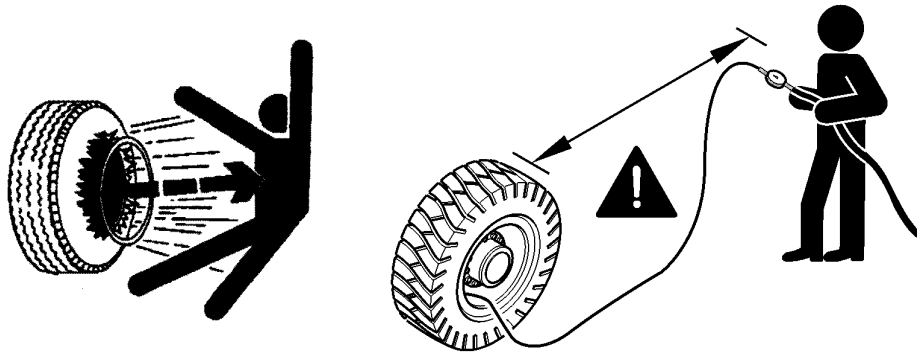

Fig. 961: Check tyre pressure

**DANGER**

Exploding tyres!  
Danger to life.

- ▶ Do not reinflate depressurised tyres.
- ▶ Use a sufficiently long tyre inflation hose with a self-retaining valve.
- ▶ Stay to the side of tyre in the safe area.

The tyre pressure affects the working behaviour of the machine.

Manufacturer	Type	Size	Air pressure
Dual tyres			
Mitas	NB38	9.00–20	7.00 bar
Mitas	EM22	9.00–20	7.00 bar
Mitas	EM22	10.00–20	7.50 bar
Mitas	EM22	290/90–20	9.00 bar
Nokian	Armor Gard	9.00–20	7.50 bar
Single tyres			
Alliance	HD I-331	500/45–20	6.00 bar
Alliance	HD I-331	600/45-22.5	6.00 bar
Mitas	TR-12	500/45–20	6.00 bar
Mitas	TR-12	600/45-22.5	6.00 bar

Tab. 138: Tyre pressure table

- ▶ See table for specified value.
- ▶ Connect measuring instrument
- ▶ Check tyre pressure.
- ▶ Correct tyre pressure if necessary.

---

**NOTICE**

Unsuitable gear oil!  
Damage to gearbox.

- ▶ Exclusively use oil in approved quality.
- 

- ▶ Remove protective cap **1** on oil tank **2**.
- ▶ Unlock cover with key.
- ▶ Open cover.
- ▶ Make sure that oil has prescribed viscosity.
- ▶ Fill oil tank **2** with prescribed oil until **MAX 3** marking is reached.
- ▶ Check oil level after 5 minutes.

If oil level is below **MAX 3** mark:

- ▶ Fill with oil.

If oil level remains unchanged:

- ▶ Screw cover onto oil tank **2**.
- ▶ Lock cover with key.
- ▶ Put protective cap **1** on oil tank **2**.

CLICK HERE TO **DOWNLOAD** THE COMPLETE MANUAL

- Thank you very much for reading the preview of the manual.
- You can download the complete manual from: [www.heydownloads.com](http://www.heydownloads.com) by clicking the link below



- Please note: If there is no response to CLICKING the link, please download this PDF first and then click on it.

CLICK HERE TO **DOWNLOAD** THE COMPLETE MANUAL