

KOBELCO

OPERATOR'S MANUAL

HYDRAULIC EXCAVATOR

SK130 IV

SK130LC IV

Applicable: SK130 IV LPU0201 ~
Applicable: SK130LC IV YPU2001~
SK1304RMMC2-1R 04/04

CLICK HERE TO **DOWNLOAD** THE COMPLETE MANUAL

- Thank you very much for reading the preview of the manual.
- You can download the complete manual from: www.heydownloads.com by clicking the link below



- Please note: If there is no response to CLICKING the link, please download this PDF first and then click on it.

CLICK HERE TO **DOWNLOAD** THE COMPLETE MANUAL

Section I- SAFETY PRECAUTIONS

B. PASSENGERS

This equipment is not intended or designed for the transportation of persons. Never allow persons to ride on the machine. Serious injury or death can result from allowing passengers on or in the machine.

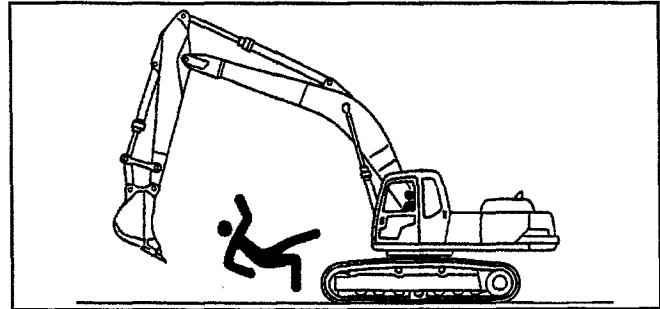

NO PASSENGERS

C. TRAVEL

Make certain of the location of the Travel Motors before operating travel controls. Sound Horn before, and use Travel Alarm when moving the machine to inform persons that the machine is travelling. Position the attachment as shown in illustration before beginning travel. Move the machine at slow speeds. Do not turn suddenly on rough terrain. Avoid travelling over obstacles. Should it become necessary to travel over an obstacle, keep the attachment low to the ground and travel at extremely slow speed.

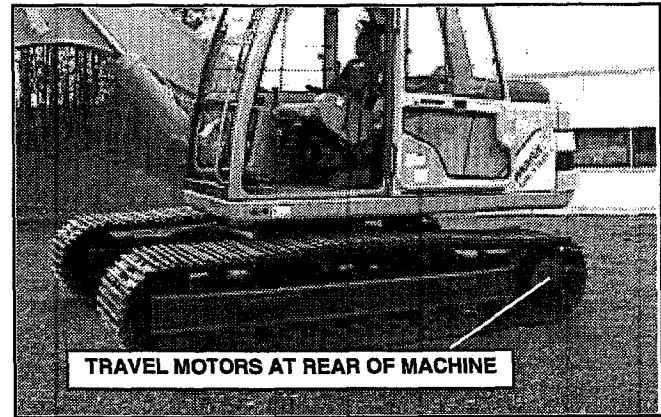

KNOW TRAVEL MOTOR POSITION

D. SWING

Make certain the Swing Area of machine is clear of all persons and obstacles before operating Swing Controls. Sound Horn before swinging machine. If necessary, have a Flagman signal operator during operation to help prevent injury to persons or damage to obstacles and equipment.

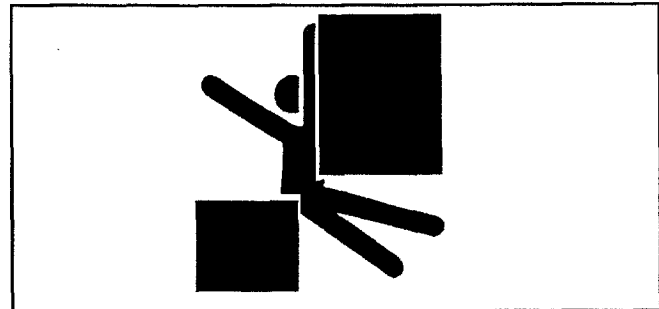

SWING SAFETY/USE SWING FLASHERS

E. BOOM, ARM & ATTACHMENTS

Give the work you are doing your undivided attention. Make certain the attachment being used is suited for the job at hand. Make certain of obstacles in the work area and operate the machine within those limits. If necessary have a Flagman signal the operator to prevent injury to persons or damage to the machine or obstacles in the work area.

ALWAYS PLACE ATTACHMENTS ON THE GROUND AND LOCK THE SAFETY LEVER BEFORE LEAVING THE CAB.

F. OPERATING ON INCLINES OR SLOPES

Operation of this machine on an incline or slope may cause the machine to become unstable or unbalanced. Work Up and Down inclines or slopes never across. Never Swing or Turn Machine around on slopes. Build a level area for the machine to operate from. Operate Controls carefully to prevent sudden movements which may cause the machine to slide or tip over. Use a Flagman to direct the operator.

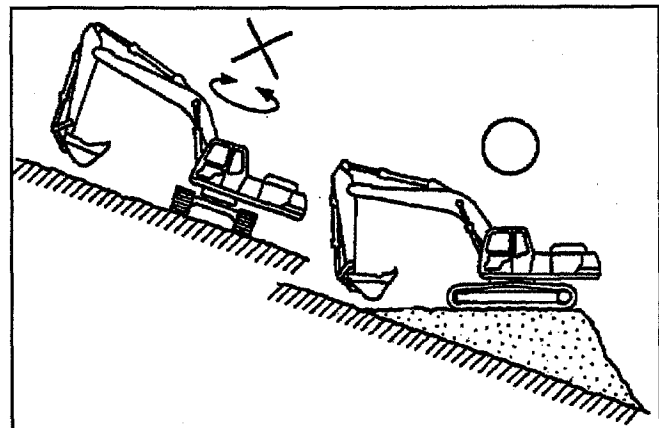

BUILD BANKING FOR SLOPE OPERATION

Section I- SAFETY PRECAUTIONS

1.9 PROHIBITED MACHINE OPERATION

The following examples of machine abuse and misuse should never be attempted by even the most experienced operator. Such abuse and misuse of this machine and its attachments can result in serious bodily injury, death, severe equipment damage and shortened service life of the machine. Under no circumstance should any of these operations be attempted. Use common sense and follow proper operation procedures found in this Operators Manual while operating this equipment.

A. DO NOT USE TRACTIVE FORCE OF THE MACHINE FOR LOADING THE BUCKET ATTACHMENT. Doing so will exert excessive force on the machine structure and front end attachments and could cause severe injury or death. Use tracks for normal travel operations only.

B. DO NOT USE SWINGING FORCE OF THE MACHINE FOR OPERATIONS. Doing so will exert excessive force to the machine structure, front end attachments and shorten life of the swinging system of the machine. Also, serious injury or death could result from such operations.

C. DO NOT PERFORM "HAMMERING" OPERATIONS WITH THE BUCKET. Performing operations such as hammering and piling will cause extensive damage to the machine and its components. These types of operations can also result in serious injury or death.

D. DO NOT USE THIS MACHINE FOR ANYTHING OTHER THAN ITS INTENDED PURPOSE. This machine is designed and manufactured for digging and loading operations only. Any other use can exert excessive force to the machine, its components, its systems and result in serious bodily injury or death to the operators and other personnel working in the vicinity of or with the machine.

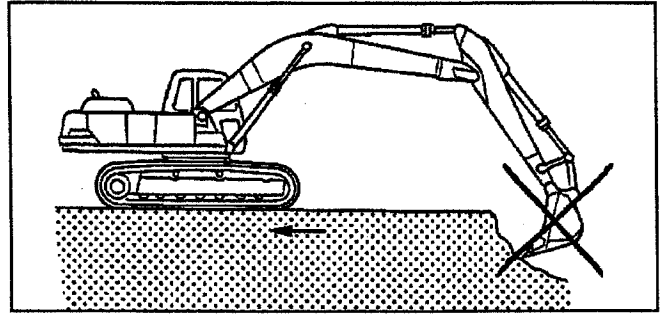

DO NOT USE TRACTIVE FORCE

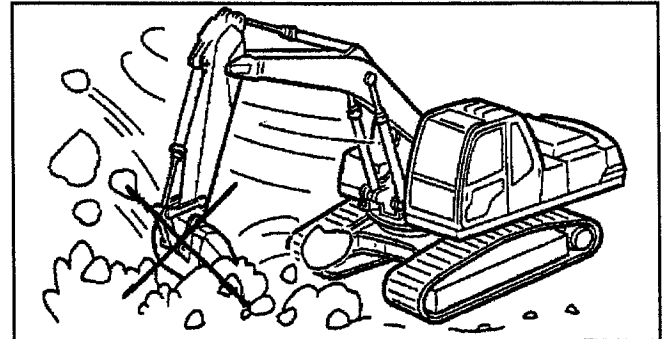

DO NOT USE SWINGING FORCE

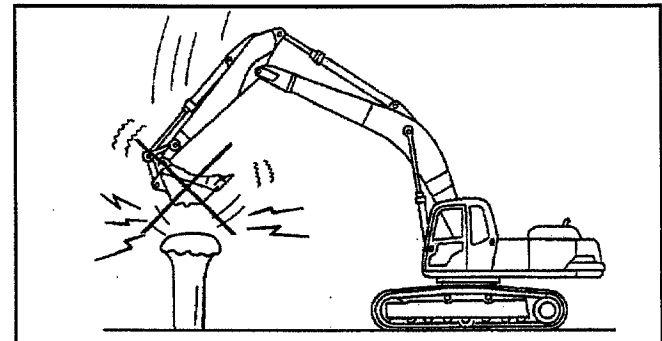

DO NOT HAMMER WITH ATTACHMENT

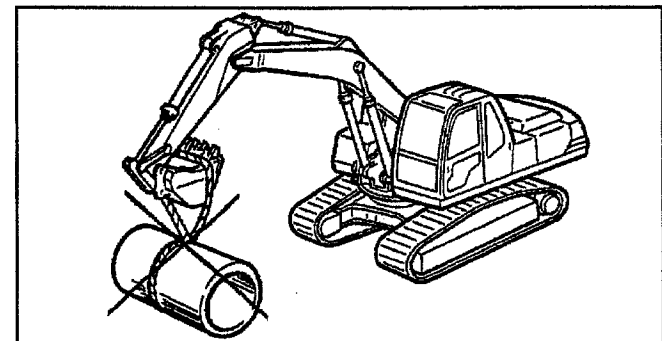

USE ONLY FOR INTENDED PURPOSE

Section II– MACHINE FAMILIARIZATION

B. LEFT HAND OPERATOR CONSOLE

FIGURE 2.12:

1. Travel Alarm Switch– FIGURE 2.13

The Travel Alarm Switch is located on the upper right corner of the left side panel. The Travel Alarm Switch is a single position rocker switch and is used to turn the Travel Alarm OFF. When travel is engaged the alarm sounds automatically. After 5 seconds of travelling, the Travel Alarm can be turned off.



– Depress this side of switch to turn Travel Alarm "OFF" after 5 seconds of travelling.

NOTE

The travel alarm will sound again if travel is stopped and restarted. Likewise, the travel system on the machine incorporates an automatic shift from "FAST" to "SLOW" speed when certain terrain conditions are sensed. Refer to Page 1-15 for Two Speed Travel Warning.

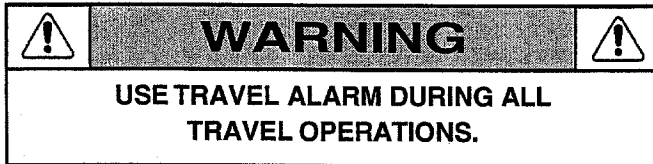

2. Extra Control Switch– FIGURE 2.14 (Optional)

The Extra Control Switch is located on the L.H. Control Console. This switch is a two position rocker switch, and is used to turn "ON" or "OFF" the Extra hydraulic function of the machine.



– Depress this side of the switch to turn "ON" the Extra function.

NOTE

It is necessary that the Extra Control Switch be kept in the "OFF" position during excavating functions, for proper machine performance.



FIGURE 2.12

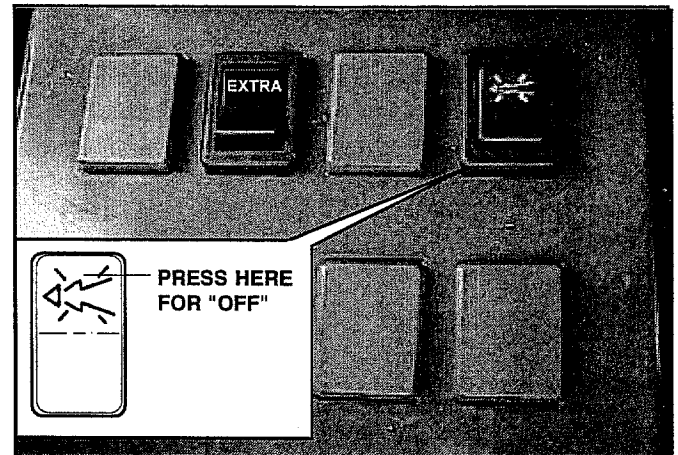

FIGURE 2.13

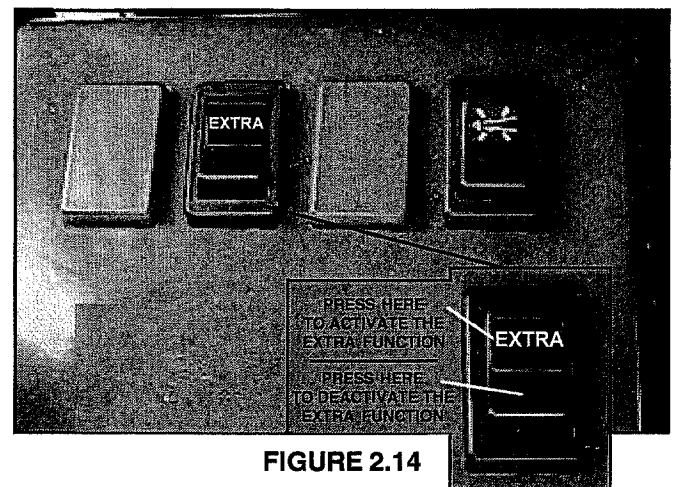

FIGURE 2.14

Section II- MACHINE FAMILIARIZATION

9. Insulated Storage Compartment

A specially insulated storage compartment is located behind the operator seat on the L.H. side. See Figure 2.42.

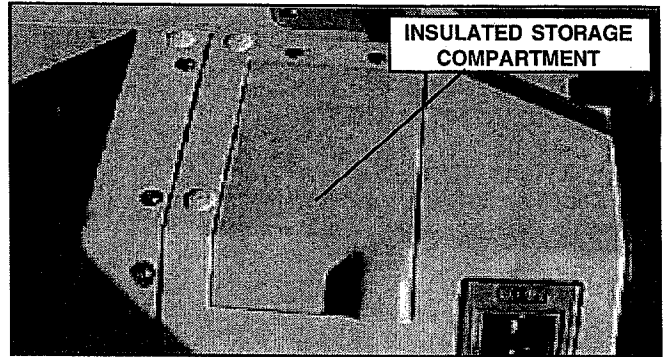

FIGURE 2.42

10. Storage Compartment

The Operator and Parts Manual Storage compartment is a pouch located on the back of the Operators Seat. Keep the Operator and Parts Manual for this machine in this location at all times for quick, easy reference. See Figure 2.43.

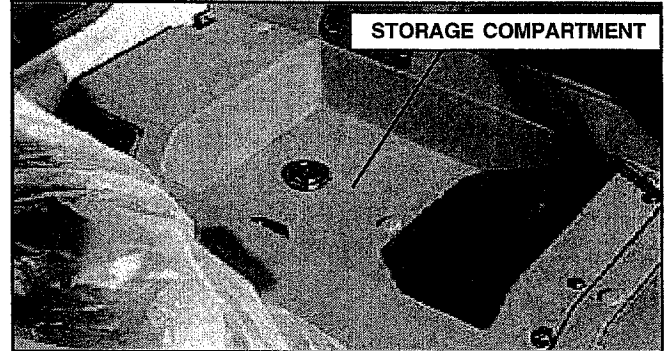

FIGURE 2.43

11. Manual Storage

The Operator and Parts Manuals for the Machine should be stored in the pouch located on the back of the Operators Seat. Keep these Manuals in this location at all times for availability and quick reference. See Figure 2.44.

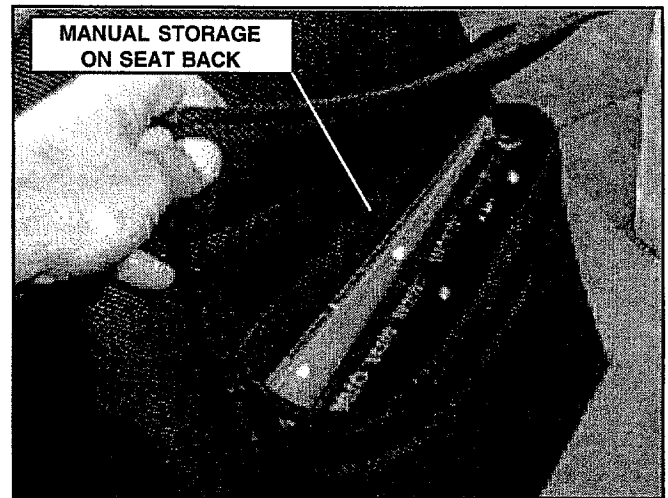

FIGURE 2.44

12. OPERATOR SEAT ADJUSTMENTS

The operator seat incorporates several adjustment mechanisms to insure operator comfort, ease of operation and operator safety. The adjustment areas are as follows:

a. Operator Weight Adjustment- FIGURE 2.45

1. Rotate the weight adjustment knob until weight closest to the weight of the operator is at the top of the dial.

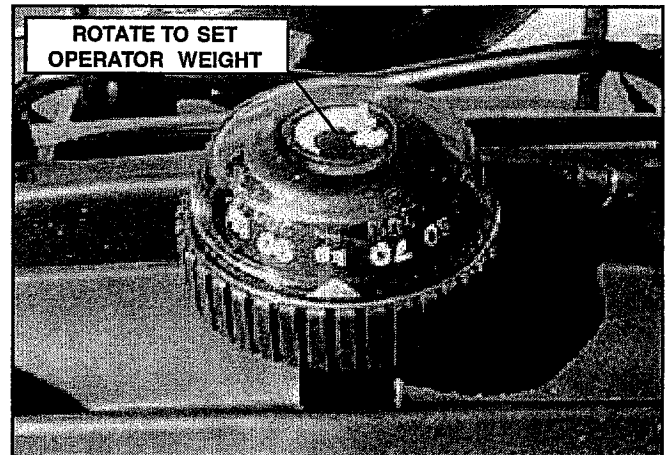

FIGURE 2.45

Section III- BASIC MACHINE OPERATION

3.5 MACHINE WARM UP

A. ENGINE

1. Allow the engine to run for 5 minutes under no load conditions with Throttle Control at low idle position. See Figure 3.15.
2. During warm up, visually and audibly inspect engine for abnormal conditions such as unusual exhaust color, excessive vibrations and excessive or unusual noises.
3. Should problem areas be noticed, stop engine, locate and repair areas before restarting or operating the machine.

B. HYDRAULIC OIL

1. Do not operate machine until the Cold Hydraulic Oil Indicator Lamp is out. See Figure 3.16.
2. Move Throttle Control to "HI" idle position.
3. Operate Bucket in and hold over relief for 10 to 15 seconds, then operate bucket out and hold over relief for 10 to 15 seconds. Repeat this operation for 5 to 10 minutes to help oil to reach operating temperature. See Figure 3.17.
4. Move Throttle Control to Mid position and operate the Boom, Arm and Swing controls for 5 to 10 minutes each. See Figure 3.18A.
5. When the Cold Hydraulic Oil Indicator Lamp is out, normal machine operations may begin.

C. HYDRAULIC OIL IN FRIGID TEMPERATURES

1. Perform normal Hydraulic Oil Warm-Up procedures. Perform these until Indicator Lamp is out. Warm-Up time will take longer in frigid temperatures.

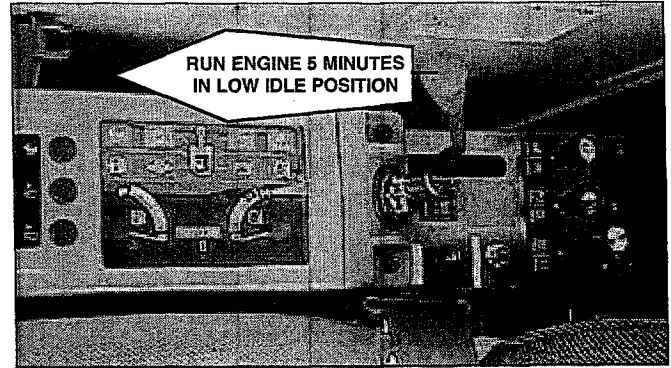

FIGURE 3.15

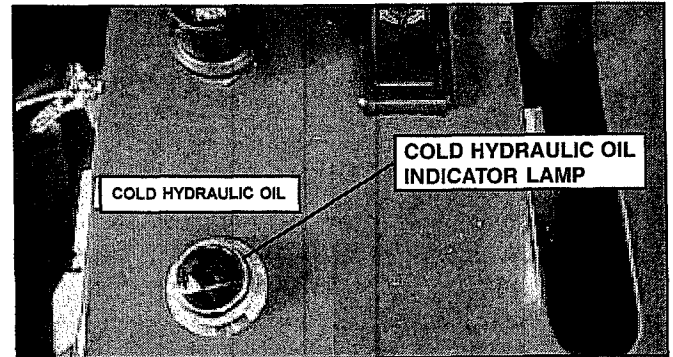

FIGURE 3.16

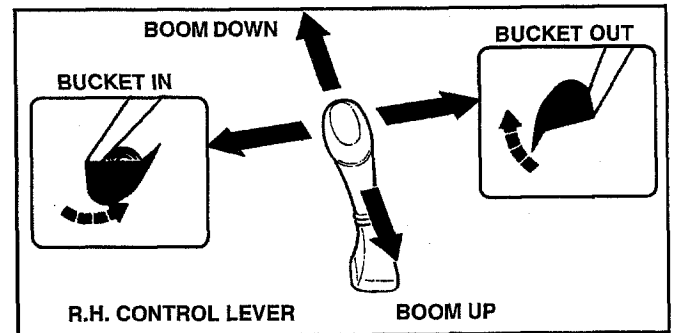

FIGURE 3.17

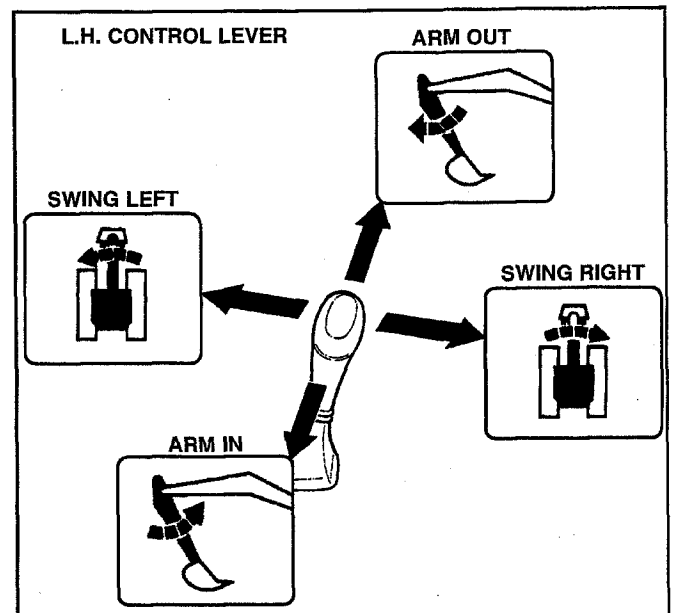

FIGURE 3.18A

NOTE

If machine is operated in frigid temperatures daily, it may be necessary to change the Hydraulic Oil to an oil designed for operation in frigid climates. Refer to maintenance section for hydraulic oil specifications.

CAUTION

During operation of the machine with cold hydraulic oil, the operator may experience slow or unexpected movement of functions. Damage to Hydraulic components may result due to the cold oil not providing adequate lubrication.

NOTE

If your machine is equipped with the **OPTIONAL HYDRAULIC WARM-UP CIRCUIT**, follow instructions given on next page.

Section III- BASIC MACHINE OPERATION

3.8 PRACTICES TO IMPROVE EFFICIENCY

A. Use Arm Pulling Action- FIGURE 3.41

Operate the bucket at shallow depths and use the Arm Pulling Force to fill the bucket. Setting the bucket too deep will decrease the machine's efficiency.

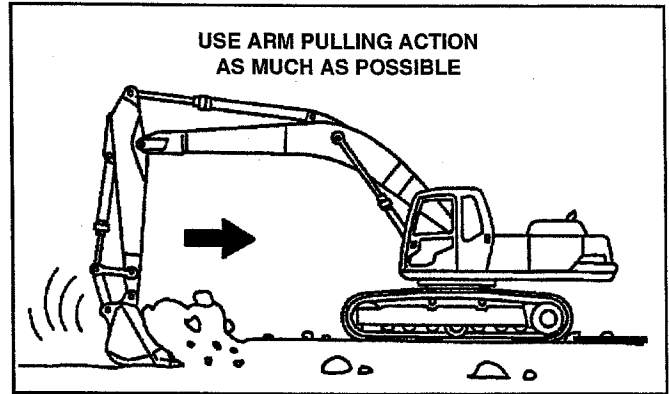

FIGURE 3.41

B. Operate Boom Smoothly- FIGURE 3.42

Always begin and end Boom Operation slowly with smooth careful movement of the control lever. Do not perform sudden starts and stops of the boom as this creates unnecessary stress on the machine and its components.

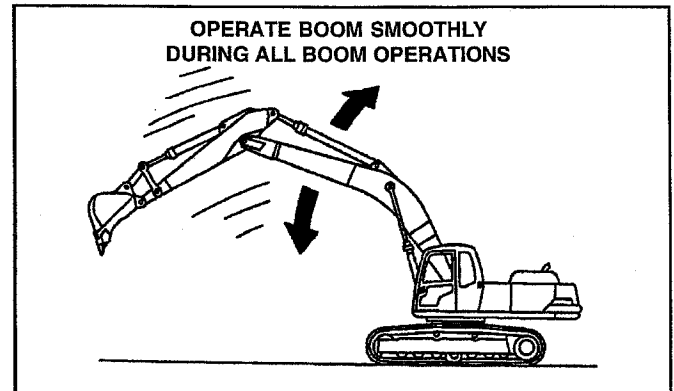

FIGURE 3.42

C. Bucket Teeth Direction- FIGURE 3.43

Always point bucket teeth in the direction the machine will be digging to reduce digging resistance and the possibility of bucket teeth damage.

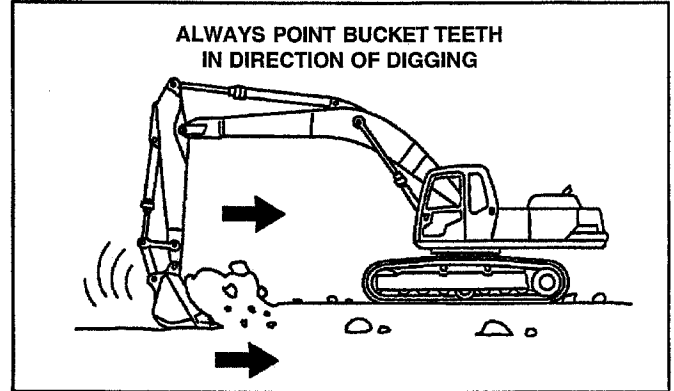

FIGURE 3.43

D. Maximum Digging Force Position- FIGURE 3.44

The attachment will provide maximum digging force when the Arm and Boom are at 90° ~ 110° of each other.

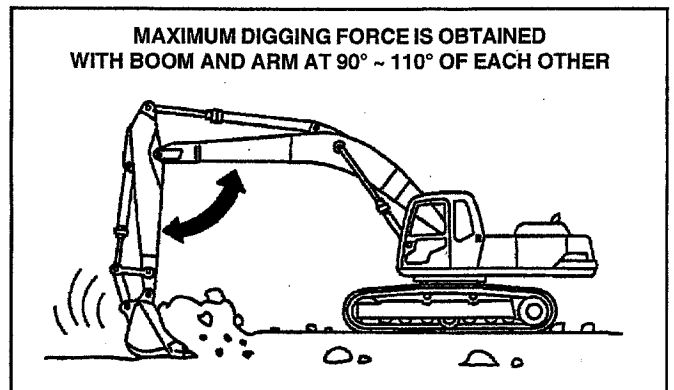

FIGURE 3.44

CLICK HERE TO **DOWNLOAD** THE COMPLETE MANUAL

- Thank you very much for reading the preview of the manual.
- You can download the complete manual from: www.heydownloads.com by clicking the link below



- Please note: If there is no response to CLICKING the link, please download this PDF first and then click on it.

CLICK HERE TO **DOWNLOAD** THE COMPLETE MANUAL

SECTION IV- MAINTENANCE

4.1 GENERAL INFORMATION

| | | |
|-------------------------------------------------------------------------------------------------------------------------------------------------------------------------------------------|----------------|---|
| ⚠ | WARNING | ⚠ |
| READ, UNDERSTAND AND FOLLOW ALL SAFETY PRECAUTIONS CONTAINED IN THIS MANUAL BEFORE PERFORMING ANY INSPECTION OR MAINTENANCE PROCEDURES TO THIS MACHINE, ITS SYSTEMS OR COMPONENTS. | | |

A. It is recommended by KOBELCO AMERICA, Inc. that an Inspection and Maintenance Schedule be developed and maintained on a regular basis for this machine. Developing and maintaining such a schedule, helps to keep the machine in optimum operating condition. See Figure 4.1.

B. The information contained in this Section gives the proper procedures for performing Inspection and Maintenance functions for this machine. Use these procedures when performing Inspection and Maintenance as they will guide the Technician step by step for each procedure. Also, refer to the Inspection and Maintenance Charts for general service interval recommendations.

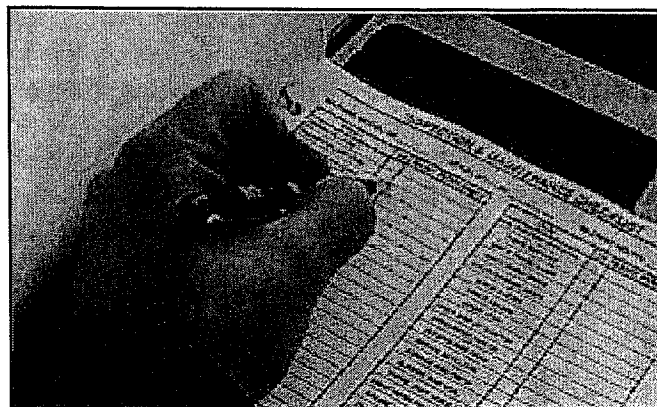

FIGURE 4.1

NOTE

The Inspection and Maintenance Charts provided give only general time intervals. It may be necessary to develop a Custom Schedule to perform machine maintenance at more frequent intervals based on the work conditions.

C. Use only KOBELCO oils, fluids, lubricants, filters and replacement parts to keep machine in optimum operating condition. See Figure 4.2.



FIGURE 4.2

4.2 GENERAL SAFETY

A. Disposal of Hazardous Waste- FIGURE 4.3

Dispose of waste oils, fluids, lubricants, filters and other hazardous waste properly.



FIGURE 4.3

| | | |
|-----------------------------------------------------------------------------------------------------------------------------------|----------------|---|
| ⚠ | CAUTION | ⚠ |
| Dispose of all Hazardous Waste in accordance with Federal, State, and Local Government Environmental Regulations, Laws and Codes. | | |

B. Keep Machine Clean- FIGURE 4.4

Thoroughly clean machine before performing Inspection and Maintenance procedures. It is easier and safer to locate problems, perform maintenance and also reduces the risk of Hydraulic System contamination when machine is clean.

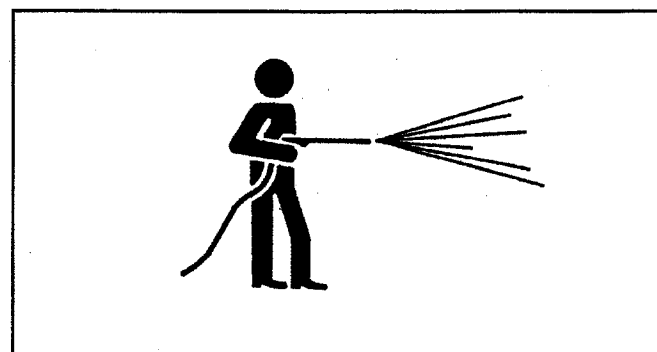

FIGURE 4.4

Section IV- MAINTENANCE

G. AIR CLEANER

1. Open L.H. Access Panel to gain access to the Engine Air Filter. See Figure 4.24. Secure door open with door lock bar while performing maintenance.

NOTE

Perform air filter maintenance with engine stopped or serious engine damage could result.

2. Remove Wing Nut from the Air Cleaner cover. See Figure 4.25.
3. Remove Wing Nut from the Air Cleaner Outer Element and remove element from the housing. See Figure 4.26.
4. Remove the Wing Nut from the Inner Element and remove element from the housing. See Figure 4.26.

CLEANING AND INSPECTION

Clean and inspect the filter elements. Replace them if necessary. Blow-out the outer filter with low pressure compressed air, from inside out. Use a light source inside the elements for inspection. Do not use any elements that have rips, tears, or damage to the filter media. *Do not clean the inner safety air filter element! It must be replaced only, when dirty.*

5. Clean the inside of the housing using a clean, lint free cloth dampened with water.
6. Thoroughly dry the inside of the housing with a clean, dry, lint free cloth.
7. Reinstall Air Cleaner Elements in reverse order. See Figure 4.26.

NOTE

Filter Elements should be serviced when the Engine Air Cleaner indicator lamp lights on the Gauge Cluster Display. See Figure 4.27.

NOTE

For additional Air Filters, contact an authorized KOBELCO Dealer and order the following Part Numbers:

OUTER AIR FILTER ELEMENT- 2446R277S5

INNER AIR FILTER ELEMENT- 2446R277S6

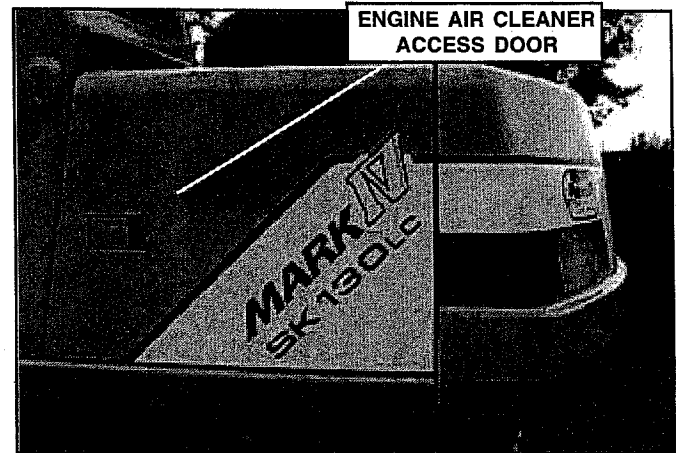

FIGURE 4.24

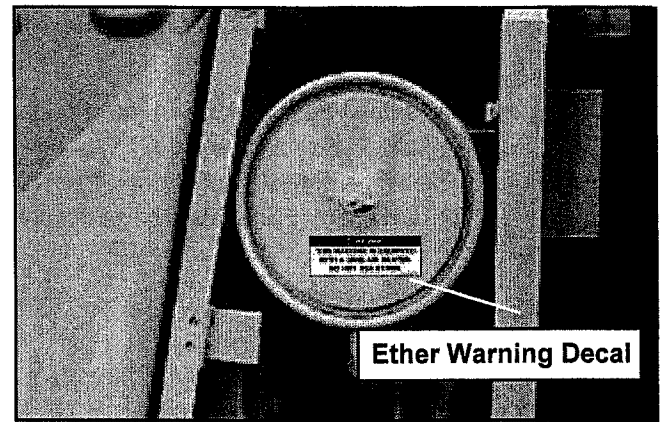

FIGURE 4.25

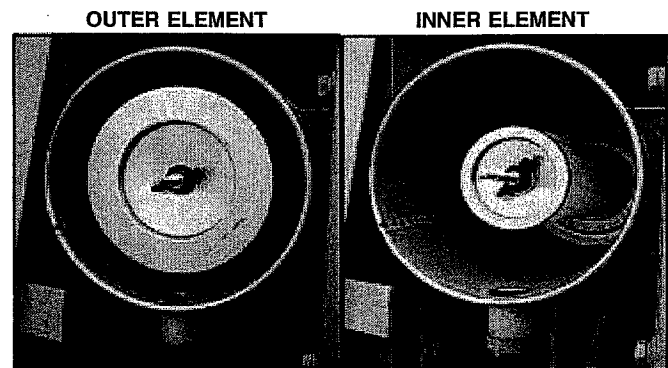

FIGURE 4.26

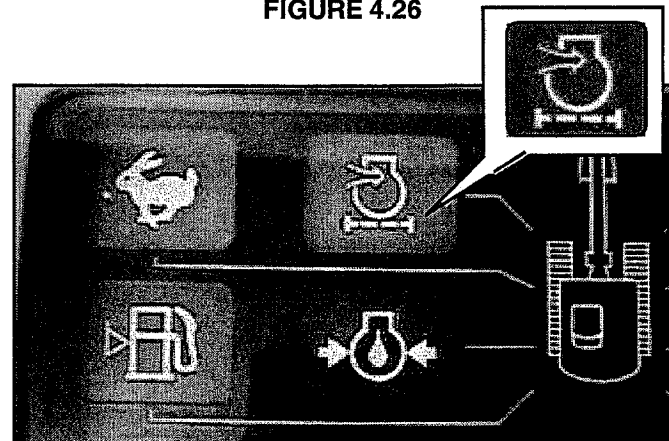

FIGURE 4.27

Section IV- MAINTENANCE

C. FUEL FILTER

Change the Fuel Filter on a new machine after the first 50 hours of operation. Then change the Fuel Filter at every 500 hours of engine operation.

NOTE

One new Fuel Filter is shipped with the machine in the support kit. This is to be used at the 50 hour filter change.

1. Raise engine cover and locate the fuel filter on the L.H. side of engine. See Figure 4.68.
2. Using appropriate filter wrench, turn counter-clockwise to remove Fuel Filter.
3. Empty contents of Fuel Filter into a waste container.
4. Remove "O"-Ring from filter head. See Figure 4.69.
5. With a clean, dry cloth, clean filter head mounting surface for the filter. See Figure 4.69.
6. Coat New "O"-Ring with a thin layer of fresh, clean motor oil and install onto filter head.
7. Fill Fuel Filter with fresh, clean fuel and install onto filter head. See Figure 4.70.
8. Tighten Fuel Filter according to manufacturer instructions. Do Not Use Filter Wrench to Tighten Fuel Filter.

NOTE

To help keep air from entering the fuel system, the fuel primer can be depressed several time to insure that the Fuel Filter and filter head are completely full of fuel. See Figure 4.71.

NOTE

For additional Fuel Filters, contact an authorized KOBELCO Dealer and order the following Part Number:

FUEL FILTER-YN50VU0001D2

9. Dispose of hazardous waste according to all Federal, State, and Local environmental codes, laws, and regulations.

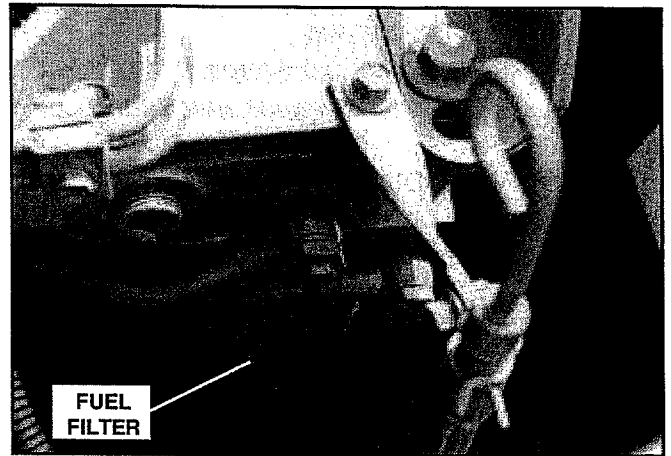

FIGURE 4.68

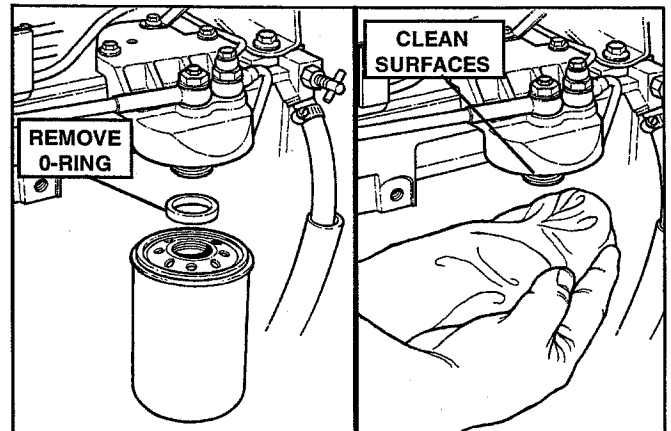

FIGURE 4.69

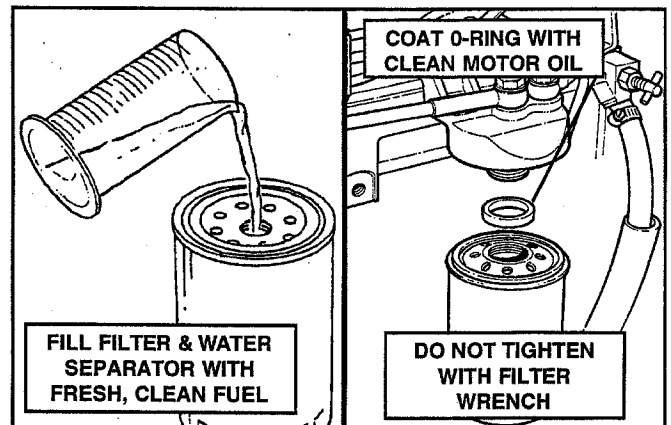

FIGURE 4.70

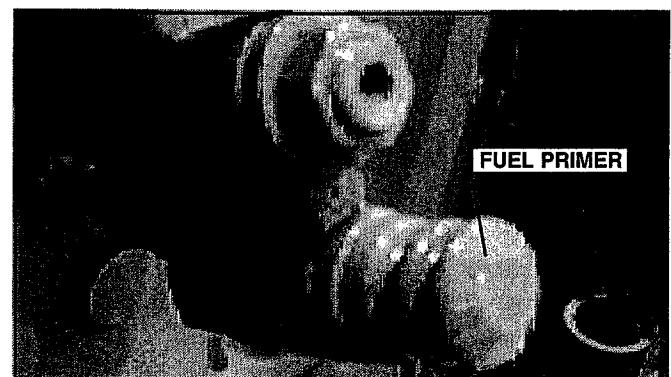

FIGURE 4.71

Section IV- MAINTENANCE

6. Idler Link to Arm Pin and Arm to Bucket Pin.
See Figure 4.105C.

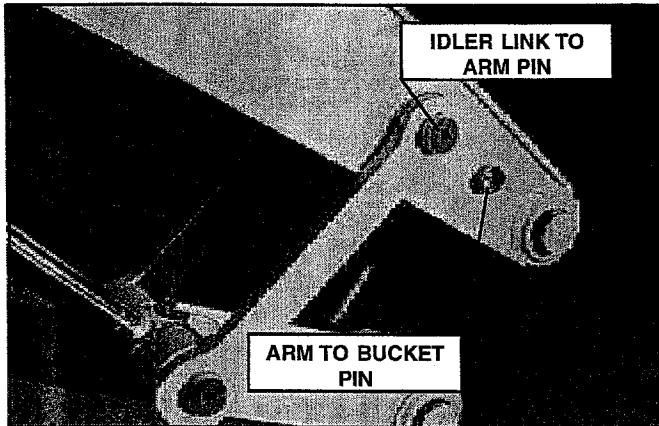

FIGURE 4.105C

7. Bucket Cylinder Head end pin. See Figure 4.106.

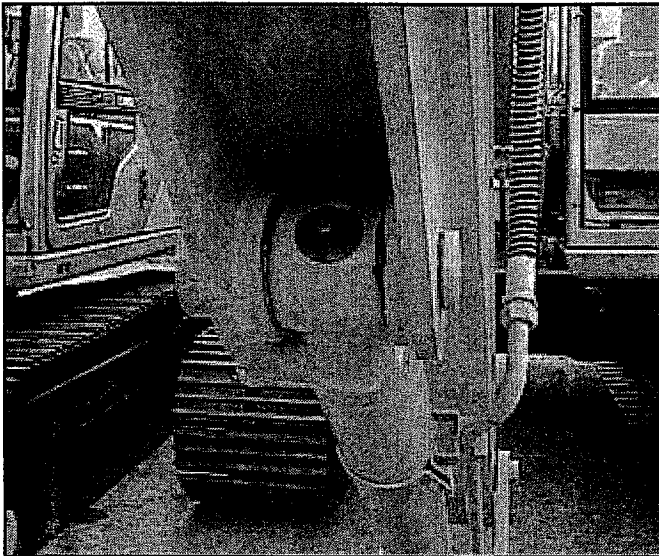

FIGURE 4.106

Section IV- MAINTENANCE

4.8 MISCELLANEOUS

A. FUSES

Follow the procedures below to replace "blown" or faulty fuses.

1. Move seat and seat base completely forward.
2. Remove Fuse Box Cover from fuse box. See Figure 4.140.
3. Locate and remove faulty fuse. Replace fuse with same amp fuse as removed.

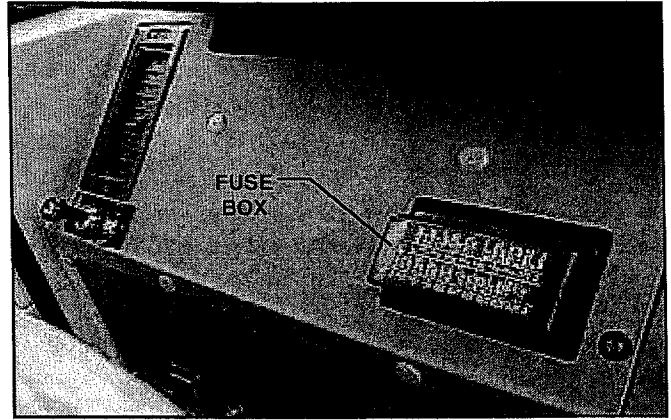

FIGURE 4.140

⚠

WARNING

⚠

NEVER REPLACE A FAULTY FUSE WITH A HIGHER AMP FUSE.
NEVER USE A "JUMPER" IN PLACE OF A FUSE.
NEVER SPLICE ACCESSORIES DIRECTLY INTO FUSE TERMINALS.

4. Refer to Fuse Box Cover or Figure 4.141 for Fuse amperage and their functions.

NOTE

When ordering replacement fuses, order the following part numbers:

- 1 AMP**– Part Number 2487U41S2
- 5 AMP**– Part Number 2479R655S10
- 10 AMP**– Part Number 2479R655S8
- 20 AMP**– Part Number 2479R655S9

NOTE

The in line fuse for the Fuel Shut Off Solenoid is located behind the Operator's Seat within the Harness Bundle. See photos below.

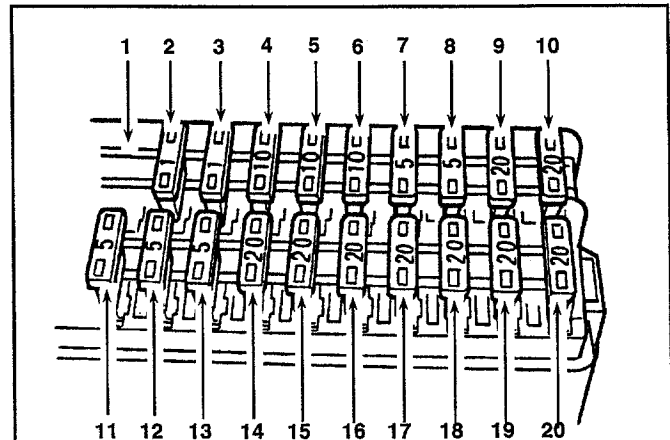

| No. | AMPS | FUNCTION |
|-----|------|--------------------------------------------|
| 1 | NONE | None |
| 2 | 1A | K.P.S.S. Solenoid Valve (N/A) |
| 3 | 1A | Variable Loading Mode Solenoid Valve (N/A) |
| 4 | 10A | Cigarette Lighter 24V |
| 5 | 10A | DC to DC Converter |
| 6 | 10A | Horn |
| 7 | 5A | DC to DC Converter Back-Up 24V |
| 8 | 5A | Cluster Back-Up 24V |
| 9 | 20A | Dome Lamp |
| 10 | 20A | Starter Switch |
| 11 | 5A | Controller (CPU) (Not Applicable) |
| 12 | 5A | Buzzer, Swing Flasher |
| 13 | 5A | Cluster (Not Applicable) |
| 14 | 20A | Wiper |
| 15 | 20A | Travel Solenoid Valve |
| 16 | 20A | Working Light |
| 17 | 20A | Working Light |
| 18 | 20A | Heater |
| 19 | 20A | Spare 24V |
| 20 | 20A | Ether Start Fan |

NOT USED ON SK130 (LC)

FIGURE 4.141

Section V- SPECIFICATIONS

5.1 SK130LC GENERAL SPECIFICATIONS

The specifications found in this section are given on the Standard SK130(LC) Mark IV Hydraulic Excavator as manufactured by KOBELCO AMERICA, INC. No modifications or options are taken in to consideration in regard to these specifications.

A. MACHINE DIMENSIONS- Figure 5.1

1. These dimensions consider the following:
 - a. Standard Boom- 4.6 meter (15'-1").
 - b. Standard Arm- 3.0 meter (9'-10").
 - c. Bucket- 0.40m³ (0.52 cubic yard).
 - d. Shoe- 600mm (23.6") Triple Grouser.

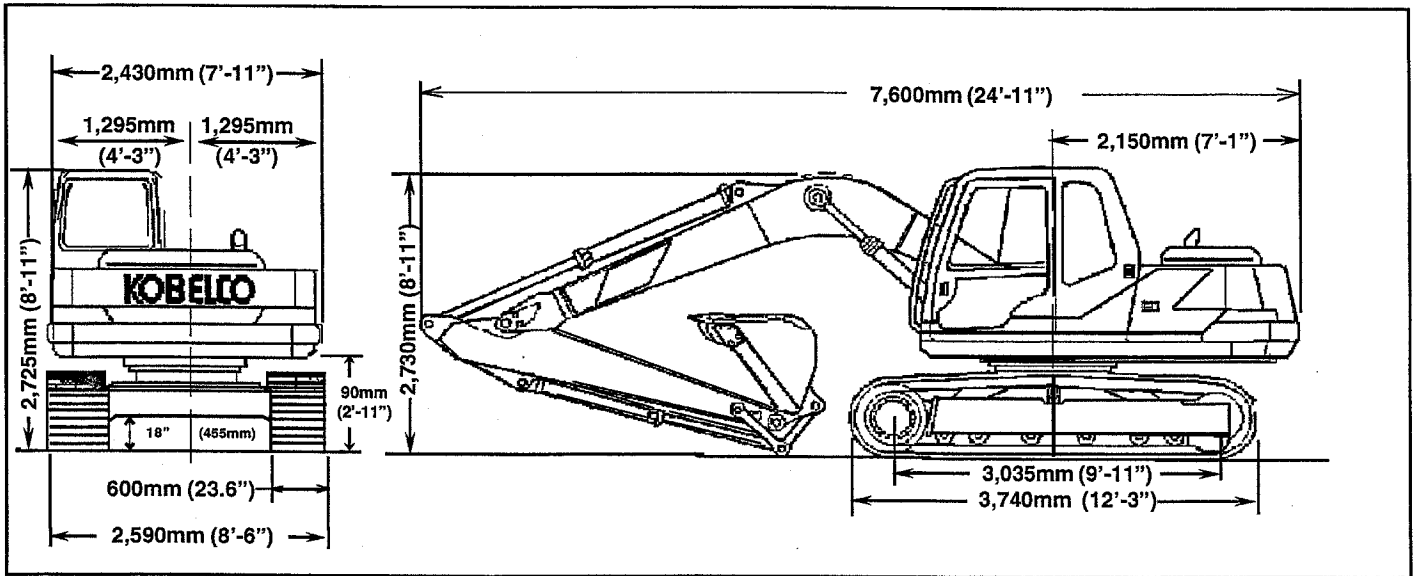

FIGURE 5.1

B. ATTACHMENT WORKING RANGES- Figure 5.2

1. Standard Attachment Working Ranges:
 - a. BOOM- 4.6 M (15'-1")
 - b. ARM- 3.0 M (9'-10")
 - c. BUCKET- SAE Heaped 0.40m³ (0.52 cu yd)
Struck 0.30m³ (0.39 cu yd)
Width with Side Cutters- 820mm (32")
Width w/o Side Cutters- 720mm (28")
Weight- 320kg (710 lbs)

| ITEM | FUNCTION | m | ft - in |
|------|--------------------------------------------------------------|------|----------|
| a | Maximum Digging Reach | 8.74 | 28'- 8" |
| b | Max Digging Reach at Ground Level | 8.61 | 28'- 3" |
| c | Maximum Digging Depth* | 6.07 | 19'- 11" |
| c' | Maximum Depth-Bucket Hinge Pin | 4.82 | 15'-10" |
| d | Maximum Digging Height* | 8.81 | 28'- 9" |
| d' | Max. Height-Bucket Hinge Pin | 7.64 | 25'- 1" |
| e | Vertical Clearance for Highest Dumping Sweep of Bucket Teeth | 6.40 | 20'- 11" |
| f | Minimum Dumping Clearance | 1.53 | 5'- 0" |
| g | Max. Vertical Wall Digging Depth | 5.33 | 15'- 3" |
| h | Minimum Front Swing Radius | 2.53 | 8'- 4" |
| i | Horizontal Digging Stroke-Grnd.Lvl | 4.92 | 16'- 2" |
| j | Digging Depth at 8' Level Bottom | 5.89 | 19'- 3" |

*Without including height of shoe lugs.

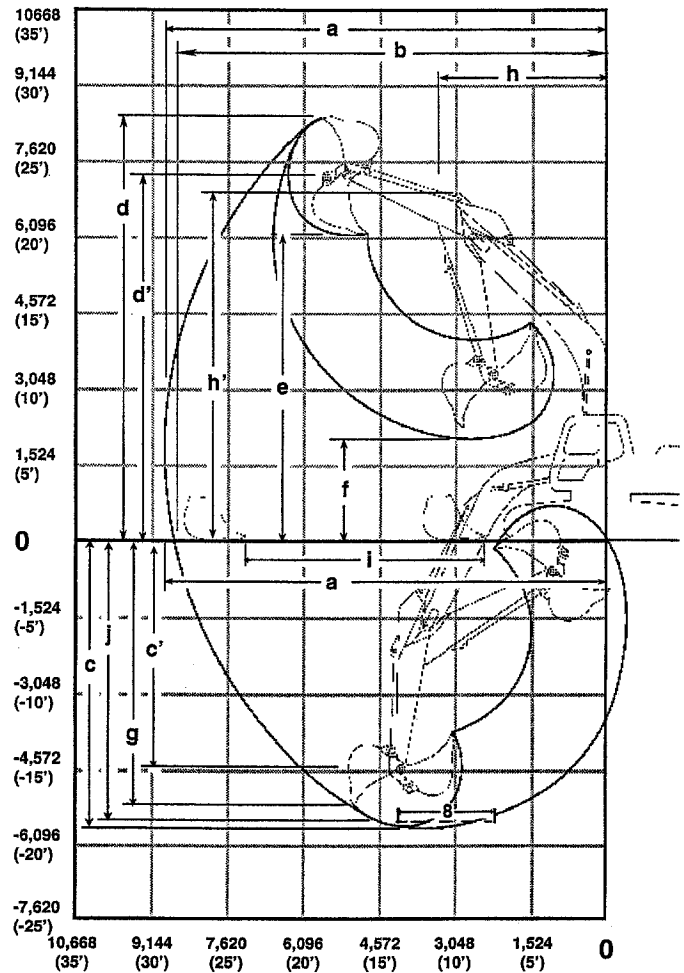

FIGURE 5.2

Section VI- TROUBLESHOOTING



| SYS | PROBLEM | PROBABLE CAUSE | POSSIBLE REMEDY |
|----------------------|---------------------------------------|------------------------------------------------------|----------------------------------|
| ENGINE | 5. Engine overheats. | a. Insufficient coolant | a. Refill coolant |
| | | b. Clogged radiator | a. Clean cooling components |
| | | c. V-belt too loose or damaged | a. Adjust or replace belt |
| | | d. Faulty thermostat | a. Replace |
| | 6. Engine exhaust is black. | a. Air cleaner clogged | a. Replace elements |
| | | b. Improper valve clearance | a. CUMMINS Serviceman |
| | 7. Poor fuel consumption | a. Fuel leak | a. CUMMINS Serviceman |
| | | b. Air cleaner clogged | a. Replace elements |
| | | c. Loose clamps on suction hose (with turbo charger) | a. Tighten clamps |
| | | d. Cracked suction hose (with turbo charger) | a. Replace w/ new hose |
| | 8. Excessive oil consumption. | a. Improper oil | a. Replace with correct oil |
| | | b. Oil leak | a. CUMMINS Serviceman |
| | | c. Improper oil replacement intervals | a. Change at correct interval |
| | | d. Improper warming-up operation | a. Refer to page 3-5 |
| | 9. Engine oil pressure does not rise. | a. Low oil volume | a. Fill to specified level |
| | | b. Oil leak | a. CUMMINS Serviceman |
| | | c. Improper oil viscosity | a. Replace with proper oil |
| | 10. Battery dies often. | a. Battery terminals disconnected loose, or corroded | a. Clean & tighten terminals |
| | | b. Low battery electrolyte | a. Fill cells w/ distilled water |
| | | c. V-belt loose or damaged | a. Adjust or replace belt |
| d. Defective battery | | a. Replace battery | |



Section VIII- OPTIONAL EQUIPMENT

8.3 NIBBLER & BREAKER SYSTEM (Cont.)

A. MACHINE SET-UP FOR NIBBLER USE - SHEAR, THUMB, GRAPPLE, ETC. BI-DIRECTIONAL - (TWO-WAY FLOW) [ONE or TWO PUMP FLOW]

| | | |
|---------------------------------------------------------------------------------------------------------------------------------------------------------|----------------|-----------------------------------------------------------------------------------|
|  | WARNING |  |
| READ, UNDERSTAND AND FOLLOW ALL SAFETY PRECAUTIONS AND OPERATION PROCEDURES FOUND IN THIS MANUAL BEFORE OPERATING THE MACHINE OR ANY ATTACHMENT. | | |

1. Pilot Circuit Selector Valve

- a. Locate the Pilot Selector Valve in front of the attachment filter housing. See Figure 8.17.
- b. Use a 4 mm hexagonal wrench and remove the safety bolt. See Figure 8.17A.
- c. Use a spanner wrench and turn the selector valve to align the arrow heads, stamped on the valve, as shown on Figure 8.17A for **two pump flow**, or Figure 8.17B for **one pump flow**.
- d. Reinstall the hexagonal head safety bolt. See Figure 8.17A.

2. Return Flow Selector Valve

- a. Use a 19mm wrench and remove the bolts that hold the panel above the Main Control Valve. Remove the panel and locate the Return Flow Selector Valve behind the attachment filter housing. See Figure 8.18.
- b. Use a 4 mm hexagonal wrench and remove the safety bolt. See Figure 8.11.
- c. Using a spanner wrench, turn the selector until the stamped arrow heads are aligned as shown on Figure 8.18.
- d. Reinstall the hexagonal head capscrew and tighten it properly.

3. Pump Flow Selector Valve

- a. Locate the Pump Flow Selector Valve. See Figure 8.19.
- b. Remove the Hexagonal Head Capscrew with a 4mm allen wrench.
- c. Using a spanner wrench, turn the selector until the stamped arrows are aligned as shown on Figure 8.19A, to select **two pump flow**, or as shown on Figure 8.19B to select **one pump flow**.
- d. Reinstall the hexagonal head capscrew and tighten it properly.

4. Attachment Flow Selector Valves

- a. Locate the Att. Flow Selector Valves on both sides of the Arm. See Figure 8.20.
- b. Using a spanner wrench, turn the selector valves until the stamped arrows are aligned with the direction of the flow. Figure 8.20 show the valves on the lock position.

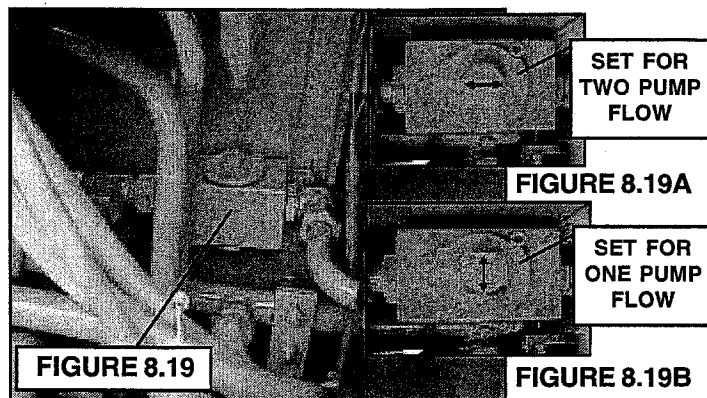
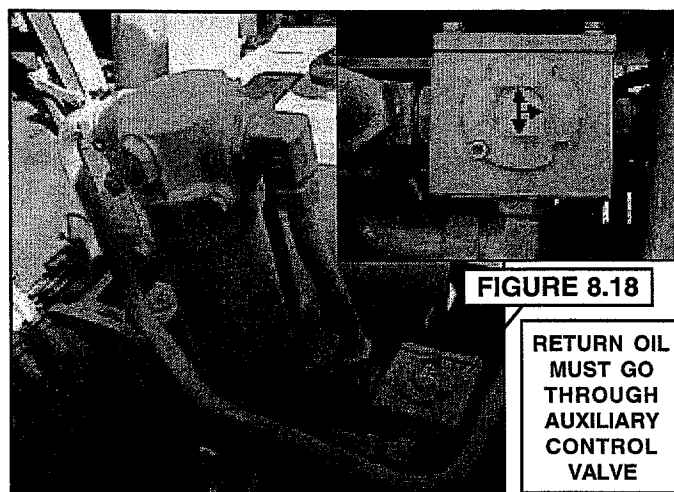
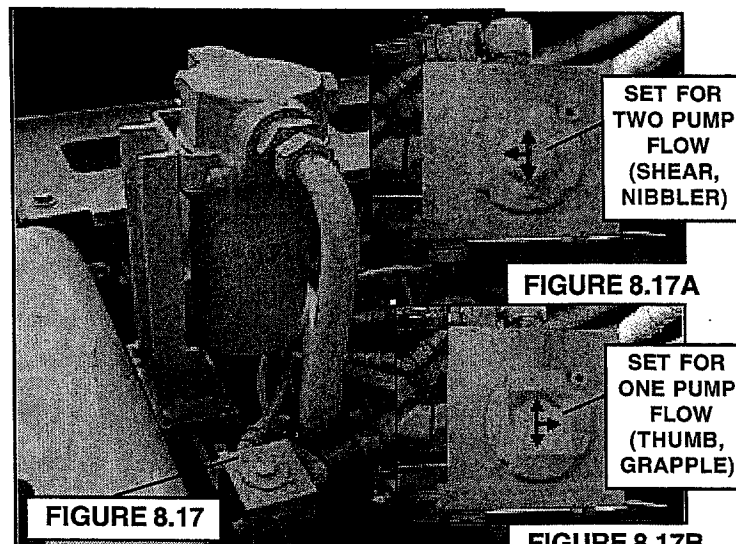

**! CAUTION !
CHECK FLOW
REQUIREMENT
OF ATTACHMENT
BEFORE
SELECTING
TWO PUMPS !**

FIGURE 8.20
Located on both sides of the arm by the bucket end connection.

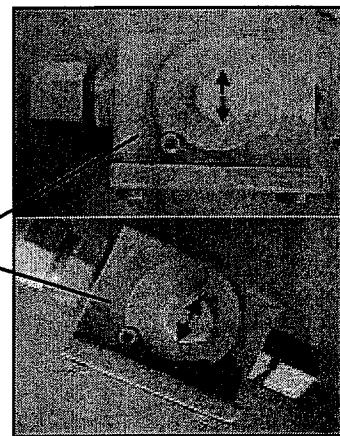

CLICK HERE TO **DOWNLOAD** THE COMPLETE MANUAL

- Thank you very much for reading the preview of the manual.
- You can download the complete manual from: www.heydownloads.com by clicking the link below



- Please note: If there is no response to CLICKING the link, please download this PDF first and then click on it.

CLICK HERE TO **DOWNLOAD** THE COMPLETE MANUAL