

FD45 DISC SAW FELLING HEAD

(Serial No. FD45X008141 --)

OPERATOR'S MANUAL FD45 DISC SAW FELLING HEAD

F386945 Issue D6 (ENGLISH)

CALIFORNIA
Proposition 65 Warning

Diesel engine exhaust and some of its constituents are known to the State of California to cause cancer, birth defects, and other reproductive harm.

If this product contains a gasoline engine:

 **WARNING**

The engine exhaust from this product contains chemicals known to the State of California to cause cancer, birth defects or other reproductive harm.

The State of California requires the above two warnings.

**Worldwide Construction
And Forestry Division**
LITHO IN U.S.A.

CLICK HERE TO **DOWNLOAD** THE COMPLETE MANUAL

- Thank you very much for reading the preview of the manual.
- You can download the complete manual from: www.heydownloads.com by clicking the link below



- Please note: If there is no response to CLICKING the link, please download this PDF first and then click on it.

CLICK HERE TO **DOWNLOAD** THE COMPLETE MANUAL

Beware Of Exhaust Fumes

Prevent asphyxiation. Engine exhaust fumes can cause sickness or death.

If you must operate in a building, provide adequate ventilation. Use an exhaust pipe extension to remove the exhaust fumes or open doors and windows to bring outside air into the area.

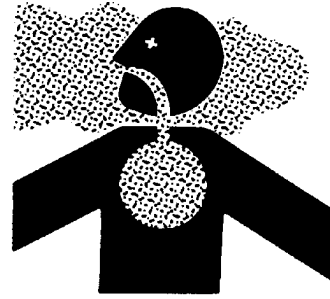

T133546 -UN-24AUG00

TX03679,00016D4 -19-14SEP00-1/1

Prevent Fires

Handle Fuel Safely: Store flammable fluids away from fire hazards. Never refuel machine while smoking or when near sparks or flame.

Clean Machine Regularly: Keep trash, debris, grease and oil from accumulating in engine compartment, around fuel lines, hydraulic lines and electrical wiring. Never store oily rags or flammable materials inside a machine compartment.

Maintain Hoses and Wiring: Replace hydraulic hoses immediately if they begin to leak, and clean up any oil spills. Examine electrical wiring and connectors frequently for damage.

Keep A Fire Extinguisher Available: Always keep a multi-purpose fire extinguisher on or near the machine. Know how to use extinguisher properly.

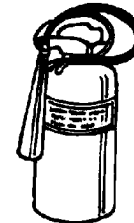
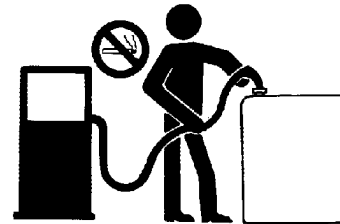

T133552 -UN-14SEP00

T133553 -UN-07SEP00

T133554 -UN-07SEP00

TX03679,00016F5 -19-25SEP00-1/1

Safety - Maintenance Precautions

Park And Prepare For Service Safely

Warn others of service work. Always park and prepare your machine for service or repair properly.

- Park machine on a level surface and lower equipment to the ground.
- Place pilot control shut-off lever in “lock” position. Stop engine and remove key.
- Attach a “Do Not Operate” tag in an obvious place in the operator’s station.

Securely support machine or equipment before working under it.

- Do not support machine with boom, arm, or other hydraulically actuated attachments.
- Do not support machine with cinder blocks or wooden pieces that may crumble or crush.
- Do not support machine with a single jack or other devices that may slip out of place.

Understand service procedures before beginning repairs. Keep service area clean and dry. Use two people whenever the engine must be running for service work.

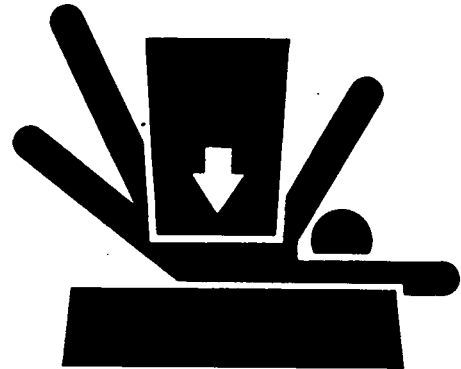

T133332 -19-14DEC01

TS229 -UN-23AUG88

TX03679,00016E9 -19-12APR01-1/1

Use Proper Lifting Equipment

Lifting heavy components incorrectly can cause severe injury or machine damage.

Follow recommended procedure for removal and installation of components in the manual.

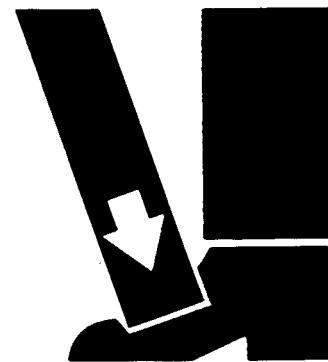

TS226 -UN-23AUG88

MR64971,0000027 -19-05DEC01-1/1

Operation — FD Series Felling Head

Basic Operation

! **CAUTION:** Nothing can replace adequate training of those in the logging woods who work on or near Feller-Bunchers. While Feller-Bunchers have been a tremendous addition to mechanized logging and have made logging a much safer occupation, it is imperative that those working on or near Feller-Bunchers realize that a Feller-Buncher is a dangerous piece of equipment that **MUST** be respected. Those on the ground working near Feller-Bunchers **MUST** maintain a safe working distance (at least 300 feet (100 meters) from the Feller-Buncher and must follow all other instructions provided on and with the Feller-Buncher and felling head. The use and operation of the saw head for any other purpose than stated in the Operator's Manual is not recommended nor approved.

OUTJ003,000094E -19-15OCT01-1/1

Principle of Operation

Drive to tree disc saw felling heads are based on a concept of continuous high speed blade motion for felling trees. The felling head is powered through the tree by machine forward travel, then clamps the tree(s) to the head after the cutting is complete.

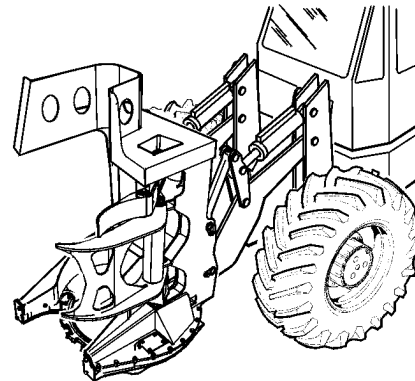

T154830 -UN-21MAY04

OUTJ003,000094F -19-15OCT01-1/1

Application

The FD45 Felling Head is designed to work in first or second thinnings where 90% of the stems are under 305mm (12 in.) diameter.

DH98466,00009D5 -19-25JUN03-1/1

3. Lock the disc saw blade to prevent free rotation by installing the locking bolt through the hole in the butt plate and thread the bolt into the threaded hole in the disc saw blade.

NOTE: Do not tighten the locking bolt.

The disc saw blade guard should be left installed unless required off for debris removal.

4. Remove debris from the felling head.

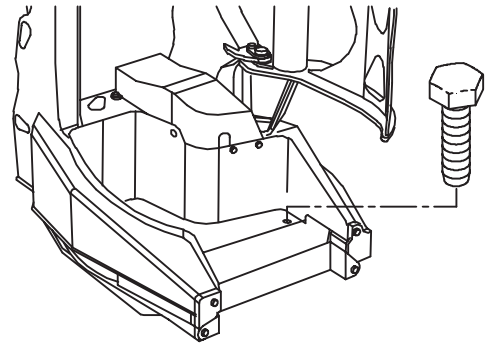

T156156 -UN-07JAN04

OUTJ001,00000B4 -19-19MAY04-2/3

5. Remove 4 bolts and open the blade access port cover to access any debris clogging the disc saw blade.

CAUTION: Saw teeth have sharp edges. Injury may occur if unprotected hands come in contact with sharp edges of the Saw teeth. Wear heavy duty protective gloves and keep fingers clear of sharp surfaces.

NOTE: Replace cover before operating saw

- 1—Blade Access Port Cover
- 2—Bolt (4 plcs)

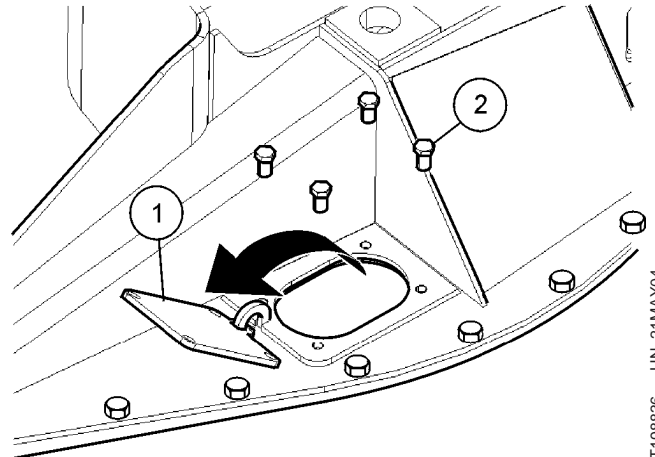

T198836 -UN-21MAY04

OUTJ001,00000B4 -19-19MAY04-3/3

Visually Inspect All Bolts and Screws

Visually inspect the felling head for any loose or damaged bolts. Replace all damaged bolts, tighten and torque any loose bolts.

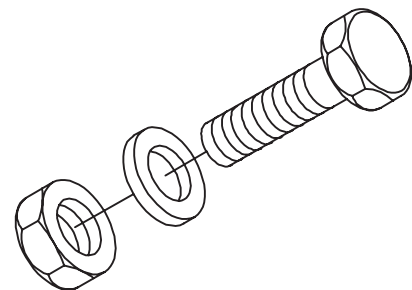

T156163 -UN-07JAN04

OUTJ003,000095B -19-15OCT01-1/1

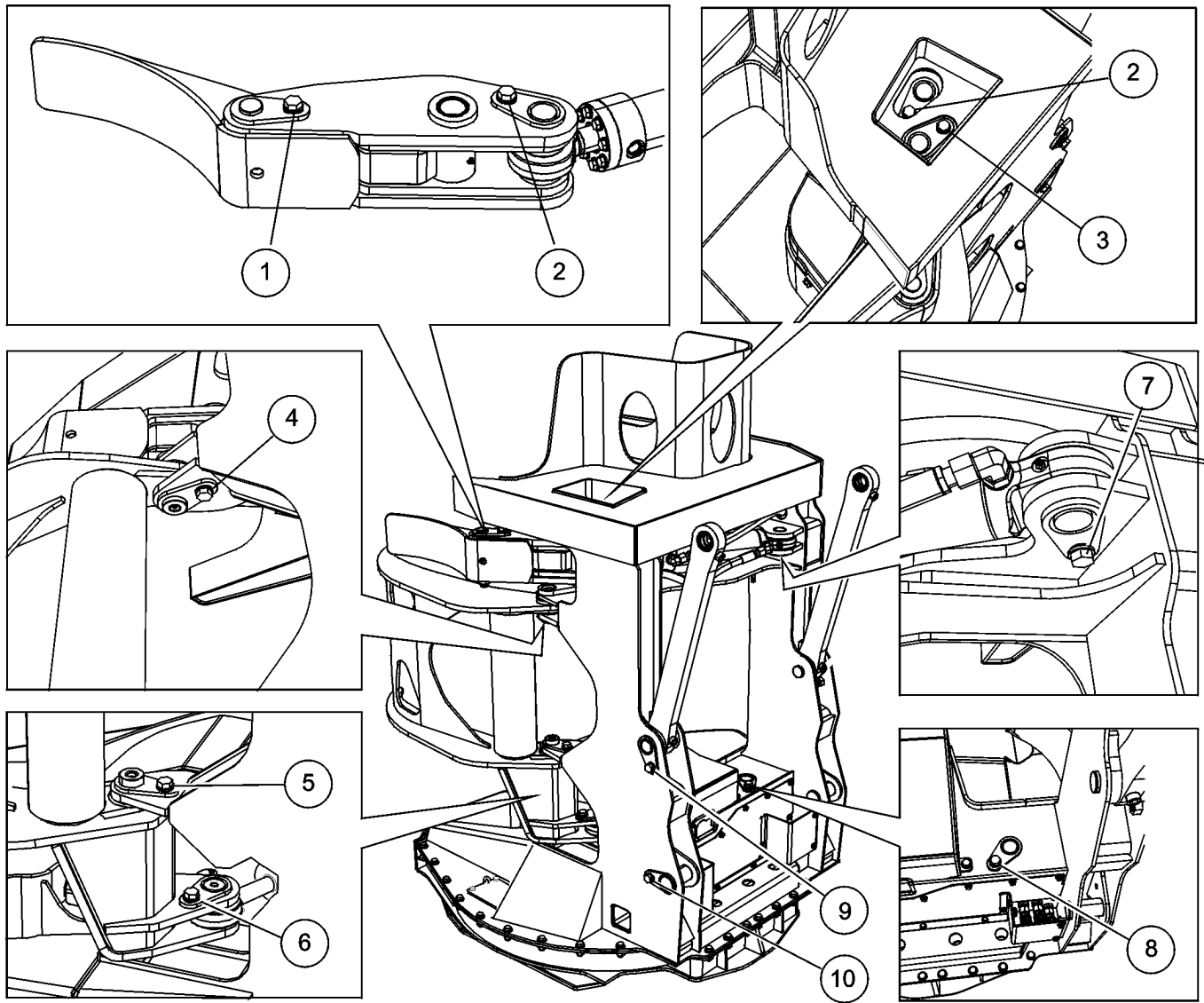

Pin Retainer Bolts Torque

The torque on the pin retainer bolts (HHCS M20 x 2.5) must be as specified.

Specification

1—Accumulator Arm Pin Retainer Bolt Torque	353-400 N•m (260-295 lb-ft)
2—Accumulator Arm Cylinder (rod end) Pin Retainer Bolt Torque.....	353-400 N•m (260-295 lb-ft)
3—Accumulator Arm Inner Pin Retainer Bolt Torque	353-400 N•m (260-295 lb-ft)
4—Harvesting Arm Upper Pin Retainer Bolt Torque	353-400 N•m (260-295 lb-ft)

5—Harvesting Arm Lower Pin Retainer Bolt Torque	353-400 N•m (260-295 lb-ft)
6—Harvesting Arm Cylinder (rod end) Pin Retainer Bolt Torque.....	353-400 N•m (260-295 lb-ft)
7—Accumulating Arm Cylinder (base end) Pin Retainer Bolt Torque.....	353-400 N•m (260-295 lb-ft)
8—Harvesting Arm Cylinder (base end) Pin Retainer Bolt Torque.....	353-400 N•m (260-295 lb-ft)
9—Link Arm Pin Retainer Bolt Torque (2 plcs.)	353-400 N•m (260-295 lb-ft)
10—Carrier Arm Pin Retainer Bolt Torque (2 plcs.)	353-400 N•m (260-295 lb-ft)

3. Remove the saw housing.

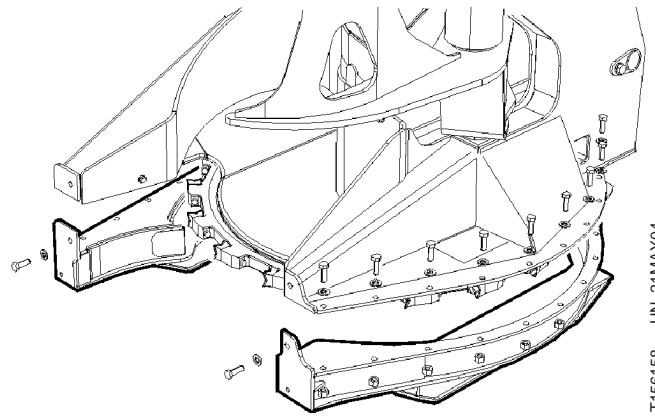

T156158 -UN-21MAY04

OUTJ003,000096D -19-16OCT01-2/8

4. Set the felling head on stands with the saw blade in a supported position. Block the wheels of the carrier to prevent accidental movement.

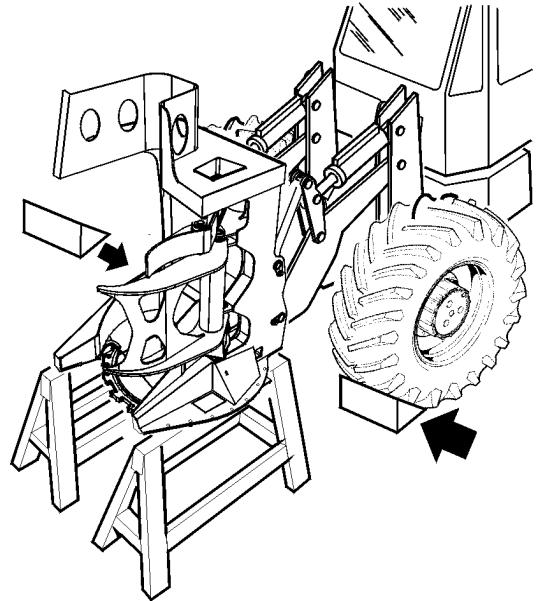

T156173 -UN-21MAY04

OUTJ003,000096D -19-16OCT01-3/8

5. Use an Allen head socket to remove 12 retaining bolts.

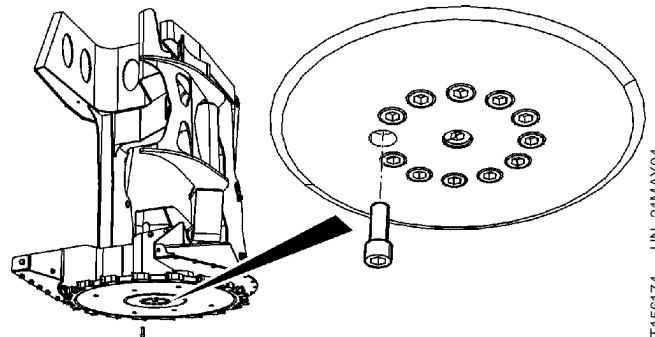

T156174 -UN-21MAY04

Continued on next page

OUTJ003,000096D -19-16OCT01-4/8

NOTE: *Items included in Tachometer Kit 701538300.

Items 11 & 12 are customer supplied.

Item 10 is factory installed.

OUTJ003,0000973 -19-16OCT01-2/2

Saw Speed Tachometer

An optional tachometer kit part number 701538300 is available for monitoring the saw speed. The kit can be purchased from your dealer. Installation and assembly instructions are included in the kit.

Continued on next page

OUTJ003,0000974 -19-16OCT01-1/4

CLICK HERE TO **DOWNLOAD** THE COMPLETE MANUAL

- Thank you very much for reading the preview of the manual.
- You can download the complete manual from: www.heydownloads.com by clicking the link below



- Please note: If there is no response to CLICKING the link, please download this PDF first and then click on it.

CLICK HERE TO **DOWNLOAD** THE COMPLETE MANUAL