

E380LC and E400LC Excavator

(PIN: 1YNE38BL_ _CXXXXXX—)

(PIN: 1YNE38BL_ _DXXXXXX—)

(PIN: 1YNE40BL_ _CXXXXXX—)

(PIN: 1YNE40BL_ _DXXXXXX—)



OPERATOR'S MANUAL E380LC and E400LC Excavator OMT401464X19 ISSUE B4 (ENGLISH)

CALIFORNIA

Proposition 65 Warning

Diesel engine exhaust and some of its constituents are known to the State of California to cause cancer, birth defects, and other reproductive harm.

If this product contains a gasoline engine:

⚠ WARNING

The engine exhaust from this product contains chemicals known to the State of California to cause cancer, birth defects or other reproductive harm.

The State of California requires the above two warnings.

**Worldwide Construction
And Forestry Division**
PRINTED IN U.S.A.

CLICK HERE TO **DOWNLOAD** THE COMPLETE MANUAL

- Thank you very much for reading the preview of the manual.
- You can download the complete manual from: www.heydownloads.com by clicking the link below



- Please note: If there is no response to CLICKING the link, please download this PDF first and then click on it.

CLICK HERE TO **DOWNLOAD** THE COMPLETE MANUAL

Emissions Control System Certification Label—Engine Model 6090HT023

⚠ CAUTION: Statutes providing severe penalties for tampering with emissions controls may apply to the user or dealer.

The emissions warranty applies to the engines marketed by John Deere that have been certified by EU Stage II.

For additional service and parts information, see www.JohnDeere.com or contact an authorized John Deere dealer for assistance.

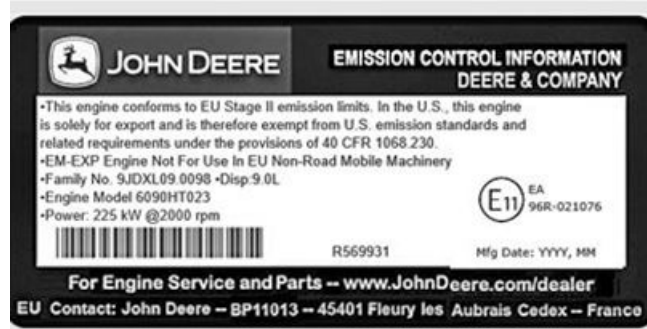

Engine Emissions Label



Engine Emissions Label

LG70251,0001C54 -19-25OCT19-2/2

YN1286877 —UN—23OCT19

YN1285784 —UN—25SEP19

Emissions Performance and Tampering

Operation and Maintenance

The engine, including the emissions control system, shall be operated, used, and maintained in accordance with the instructions provided in this manual to maintain the emissions performance of the engine within the requirements applicable to the engine's category/certification.

Tampering

No deliberate tampering with or misuse of the engine emissions control system shall take place; in particular with regard to deactivating or not maintaining an exhaust gas recirculation (EGR) or a DEF dosing system. Tampering with an engine's emissions control system will void the European Union (EU) type approval and applicable emissions-related warranties.

DX,EMISSIONS,PERFORM -19-12JAN18-1/1

Contents

Page	Page
Safety—Safety and Operator Conveniences	
Safety and Operator Convenience Features 1-1-1	
Safety—General Precautions	
Information for Eurasian Economic Union Technical Regulations Compliance 1-2-1	
Recognize Safety Information 1-2-3	
Follow Safety Instructions 1-2-3	
Operate Only If Qualified 1-2-4	
Wear Protective Equipment 1-2-4	
Protect Against Noise 1-2-4	
Avoid Unauthorized Machine Modifications 1-2-4	
Control Pattern 1-2-5	
Inspect Machine 1-2-5	
Stay Clear of Moving Parts 1-2-5	
Avoid High-Pressure Fluids 1-2-5	
Work In Ventilated Area 1-2-6	
Avoid Static Electricity Risk When Refueling 1-2-6	
High Debris Applications 1-2-6	
In Case of Machine Fire 1-2-7	
Prevent Fires, Clean Debris From Machine 1-2-7	
Clean Debris from Machine 1-2-8	
Prevent Battery Explosions 1-2-8	
Handle Chemical Products Safely 1-2-8	
Handle Starting Fluid Safely 1-2-9	
Decommissioning — Proper Recycling and Disposal of Fluids and Components 1-2-9	
Prepare for Emergencies 1-2-10	
Add Cab Guarding for Special Uses 1-2-10	
Safety—Operating Precautions	
Use Steps and Handholds Correctly 1-3-1	
Start Only From Operator's Seat 1-3-1	
Use and Maintain Seat Belt 1-3-1	
Heated and Ventilated Operator's Seat 1-3-2	
Prevent Unintended Machine Movement 1-3-3	
Avoid Work Site Hazards 1-3-4	
Keep Riders Off Machine 1-3-4	
Avoid Backover Accidents 1-3-5	
Avoid Machine Tip Over and Machine Damage 1-3-5	
Use Special Care When Operating 1-3-6	
Use Care When Swinging Machine 1-3-6	
Operate Boom With Care 1-3-6	
Avoid Power Lines 1-3-7	
Inspect and Maintain ROPS 1-3-7	
Operating on Slopes 1-3-7	
Use Special Care When Lifting Objects 1-3-7	
Travel Safely 1-3-8	
Prevent Acid Burns 1-3-8	
Add and Operate Attachments Safely 1-3-8	
Safety—Maintenance Precautions	
Park and Prepare for Service Safely 1-4-1	
Service Cooling System Safely 1-4-1	
Service Machines Safely 1-4-2	
Service Accumulator Systems Safely 1-4-2	
Use Proper Lifting Equipment 1-4-2	
Remove Paint Before Welding or Heating 1-4-3	
Make Welding Repairs Safely 1-4-3	
Drive Metal Pins Safely 1-4-3	
Safety—Safety Signs and Other Instructions	
Safety Signs and Other Instructions 1-5-1	
Operation—Operator's Station	
Pedals, Levers, and Panels 2-1-1	
Engine Speed Dial 2-1-1	
Sealed Switch Module (SSM) 2-1-2	
Sealed Switch Module (SSM) Functions 2-1-3	
Left Control Lever 2-1-5	
Right Control Lever 2-1-5	
Pilot Enable Lever 2-1-6	
Opening Upper Front Window 2-1-6	
Alternative Exit Tool 2-1-7	
Removing and Storing Lower Front Window 2-1-7	
Opening Cab Door Window 2-1-8	
Unfolding and Folding Sunshade 2-1-8	
Opening and Closing the Roof Hatch 2-1-9	
Fire Extinguisher Mounting Location 2-1-9	
Cab Dome Light 2-1-10	
Adjusting the Mechanical Suspension Seat 2-1-11	
Adjusting the Air Suspension Seat—If Equipped 2-1-12	
Seat Heater—If Equipped 2-1-13	
Adjusting Armrest Height 2-1-13	
Operating the Radio 2-1-14	
Operating the Premium Radio—If Equipped 2-1-15	
Cab Heater and Air Conditioner 2-1-16	
Operation—Monitor Operation	
Primary Display Unit (PDU) 2-2-1	

Continued on next page

Original Instructions. All information, illustrations and specifications in this manual are based on the latest information available at the time of publication. The right is reserved to make changes at any time without notice.

COPYRIGHT © 2024
DEERE & COMPANY
Moline, Illinois
All rights reserved.
A John Deere ILLUSTRATION™ Manual
Previous Editions
Copyright © 2019, 2020, 2021

Work In Ventilated Area

Engine exhaust fumes can cause sickness or death. If it is necessary to run an engine in an enclosed area, remove the exhaust fumes from the area with an exhaust pipe extension.

If you do not have an exhaust pipe extension, open the doors and get outside air into the area.

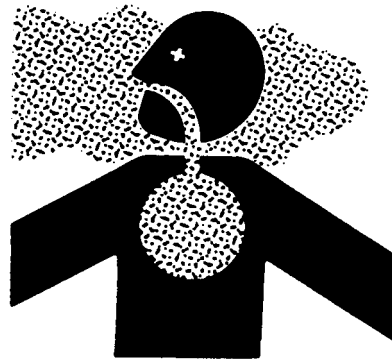

TS2220—UN—15APR13

DX,AIR -19-17FEB99-1/1

Avoid Static Electricity Risk When Refueling

The removal of sulfur and other compounds in Ultra-Low Sulfur Diesel (ULSD) fuel decreases its conductivity and increases its ability to store a static charge.

Refineries may have treated the fuel with a static dissipating additive. However, there are many factors that can reduce the effectiveness of the additive over time.

Static charges can build up in ULSD fuel while it is flowing through fuel delivery systems. Static electricity discharge when combustible vapors are present could result in a fire or explosion.

Therefore, it is important to ensure that the entire system used to refuel your machine (fuel supply tank, transfer pump, transfer hose, nozzle, fuel refill pump [if equipped], fuel refill pump hose [if equipped], and others) is properly grounded and bonded. Consult with your fuel or fuel system supplier to ensure that the delivery system is in compliance with fueling standards for proper grounding and bonding practices.



Explosion

RG22142—UN—17MAR14

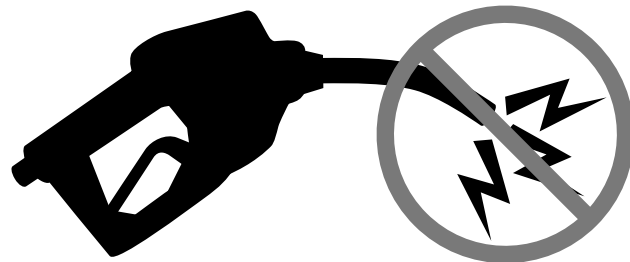

Static Discharge (fuel nozzle)

RG21992—UN—21AUG13

XL90995,0001930 -19-24OCT19-1/1

High Debris Applications

Many operations create flammable debris such as mulching, shredding, recycling, and agricultural applications. Operating in such environments may require frequent cleaning of the machine and attachments. Frequency of cleaning will vary depending on a number of factors, including operating conditions and weather.



Flammable Debris

T133552—UN—15APR13

MB60223,0005003 -19-29JUN16-1/1

Use Special Care When Operating

Never use the attachment to lift people. Do not allow anyone to ride on attachment or use it as a work platform.

Operate carefully with raised loads. Raising the load reduces machine stability, especially on side slopes or an unstable surface. Drive and turn slowly with a raised load.

Be careful when lifting loads. Never attempt to lift loads too heavy for machine. Ensure machine stability and hydraulic capability with a test lift before attempting other maneuvers. Keep bystanders away from raised loads.

DB84312,00000CA -19-21JAN16-1/1

Use Care When Swinging Machine

Ensure that all bystanders are clear before swinging the machine.

Maintain a safe operating distance between the equipment and other personnel. Never swing upperstructure with boom, stick, attachment, or load elevated above the heads of bystanders.

Be aware of the position of the counterweight.

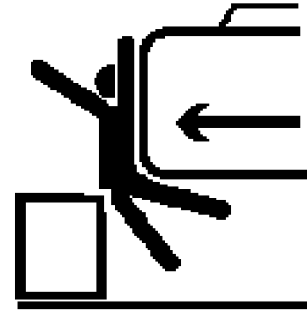

T149341—UN—19DEC01

Use Care When Swinging Machine

TX,SWING,MACH,CARE -19-08MAY20-1/1

Operate Boom With Care

Always lower the boom so that the attachment is securely supported when operation is stopped.

When moving the machine, watch that enough clearance is available on both sides and above the boom. Extra clearance may be required, particularly where the ground is uneven.

Maintain a safe operating distance between the equipment and other personnel. Never swing boom, stick, attachment, or load elevated above the heads of bystanders.

Use only prearranged and approved signaling practices.



T147349—UN—24OCT01

Operate Boom With Care

TX,OP,BOOM,CARE -19-08MAY20-1/1

4. Lift Location Decal

This decal is on the right window outside the cab.

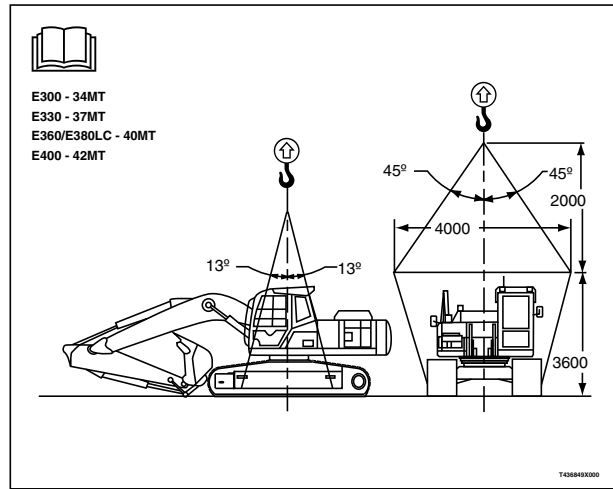

Lift Location Decal

YN00108,0001D9C -19-10JUL21-8/29

YN1286839 —UN—11OCT19

5. WARNING, Fan

Avoid injury, keep clear of the rotating fan blade.

This decal is on the plate under the hood.

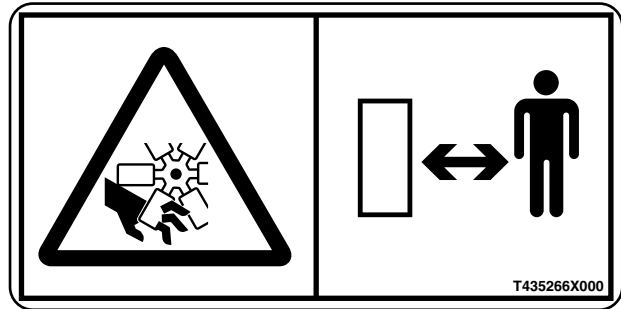

Fan Warning Decal

YN00108,0001D9C -19-10JUL21-9/29

YN1286848 —UN—08OCT19

6. WARNING, Accumulator

Avoid injury from escaping fluid. Contents of the accumulator are under pressure. Refer to proper manual for disassembly or charging instructions and equipment required.

Charge with DRY NITROGEN only.

The decal is on the frame under the door.



Accumulator Warning Decal

Continued on next page

YN00108,0001D9C -19-10JUL21-10/29

YN1125824 —UN—04JAN13

Operation—Operator's Station

Pedals, Levers, and Panels

- | | |
|-------------------------------|---|
| 1— Radio | 9— Hammer Control Pedal (if equipped) |
| 2— Pilot Enable Lever | 10— Right Travel Pedal |
| 3— Left Control Lever | 11— Right Control Lever |
| 4— Left Travel Pedal | 12— Sealed Switch Module (SSM) |
| 5— Left Travel Lever | 13— Engine Speed Dial |
| 6— Door Exit Handle | 14— Power Port |
| 7— Primary Display Unit (PDU) | 15— Heating and Air Conditioning System Control Panel |
| 8— Right Travel Lever | |

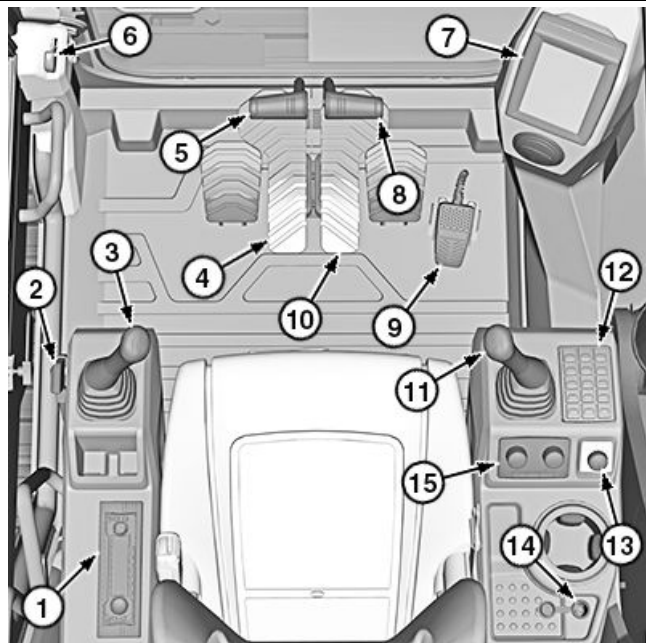

Pedals, Levers, and Panels

YN1286392 —UN—09OCT19

OUYC278,000008F -19-10OCT19-1/1

Engine Speed Dial

The engine speed dial (1) is used for adjustment of engine speed during operation.

NOTE: It may be necessary to turn the dial completely counterclockwise to reset the dial position depending on the position when the engine started.

Turn the engine speed dial clockwise to increase the engine speed.

Turn the engine speed dial counterclockwise to decrease the engine speed.

- 1— Engine Speed Dial



Engine Speed Dial

YN1276880 —UN—24APR19

OUYC278,000000D -19-21OCT19-1/1

Adjusting the Mechanical Suspension Seat

CAUTION: To prevent injury to operator and bystanders, do not adjust the seat while machine is in motion. Completely stop the machine and adjust the seat.

Avoid risk of personal injury. The operator's seat is designed for only one person at a time. Do not seat more than one person in the operator's seat.

To minimize whole body vibration injuries, operate the machine for excavator or transferring material only and ensure that the operating terrain is in good condition. Using the machine for other purposes or on rough terrain for extended periods of time may increase risk of whole body vibration injuries.

Pull up the lower fore/aft adjustment control (1) to unlock the pods. Slide the pods to desired position. Release the lever.

Pull up the upper fore/aft adjustment control (2) to unlock the seat. Slide the seat to desired position. Release the lever.

The ride height indicator (3) is used to check that the suspension is set to optimum level that is marked with the green zone based on the operator's weight. Red zone indicates that the suspension is not set at optimum ride level. Adjust the height using weight/height adjustment control (4).

Turn the weight/height adjustment control to adjust for the operator's weight and height. Turn the knob counterclockwise or clockwise to achieve proper suspension level.

Pull the seat back recline adjustment control (5) upward or push downward to adjust the seat back to desired angle.

When the seat cannot be locked to desired position, adjust the seat adjuster cable handle (6). Turn the seat adjuster cable handle clockwise to increase the locking force. Turn the seat adjuster cable handle counterclockwise to decrease the locking force.

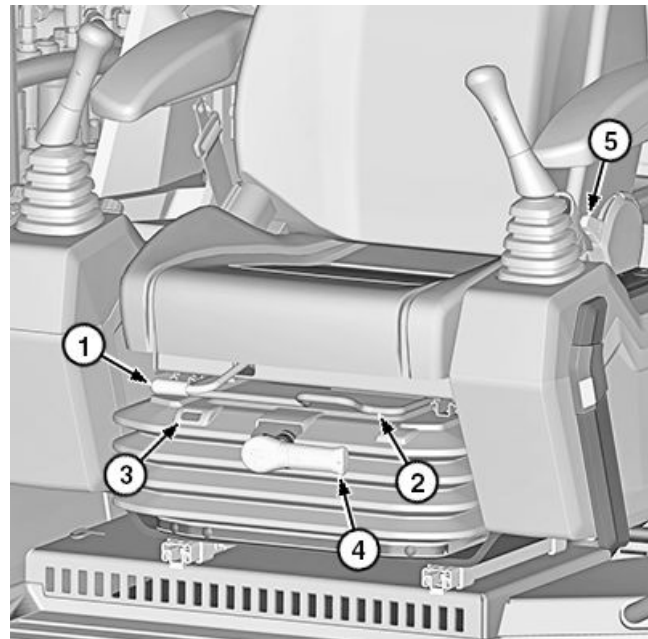

Mechanical Suspension Seat (view from front)

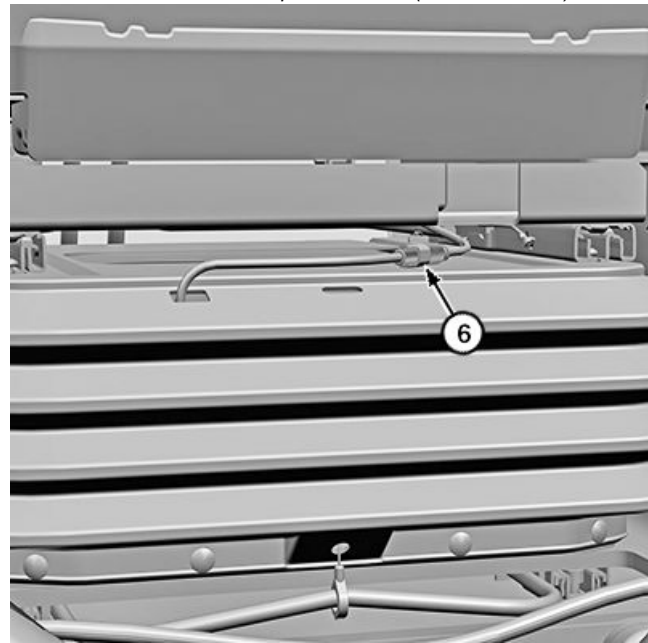

Mechanical Suspension Seat (view from rear)

- | | |
|--------------------------------------|---|
| 1— Lower Fore/Aft Adjustment Control | 4— Weight/Height Adjustment Control |
| 2— Upper Fore/Aft Adjustment Control | 5— Seat Back Recline Adjustment Control |
| 3— Ride Height Indicator | 6— Seat Adjuster Cable Handle |

OUYC278,00020AE -19-29JUN20-1/1

YN1286503 —UN—13OCT19

YN1298557 —UN—15JUN20

The white indicator illuminates when machine operates in autoshift mode.

YN00108,0001DA8 -19-27JUL21-3/3

Menu

NOTE: Translations shown on display may be abbreviated.

The MENU displays available applications that can be selected to view diagnostic information or change various operating characteristics of the machine or the display unit.

The menu icon is located on the lower right corner of primary display unit (PDU). See Monitor-Runtime Screen. (Section 2-2.)

To access MENU, touch the menu icon.

To return to previous display, touch the back icon (1).

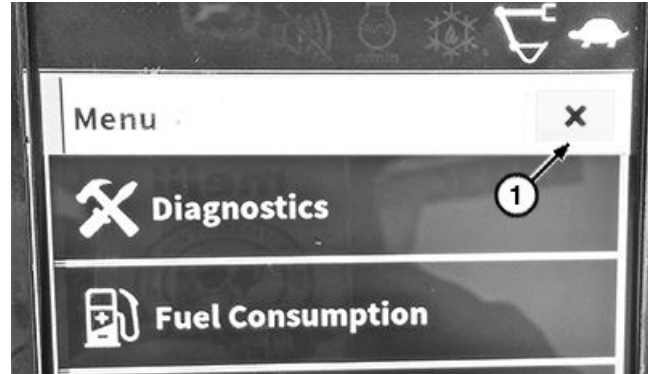

Back Icon

YN1285559 —JUN—20SEP19

1— Back Icon

MENU Items	
Menu Items	Description
DIAGNOSTICS	Provides a limited set of tools and is intended for use by service personnel and machine operators for checking stored codes, diagnostic, and troubleshooting functions.
FUEL CONSUMPTION	Allows the operator to view fuel consumption averages and the instantaneous fuel rate of the machine. If security is enabled and owner logged in, the fuel consumption under each operator personal identification number (PIN) can be viewed.
DISPLAY SETTINGS	Allows the operator to change various operating characteristics of the display unit.
JOB TIMER	Allows the operator to use a resettable timer to display job timer hours and average fuel consumption for a job timer period.
MAINTENANCE	Provides time remaining information about when various maintenance activities need to be completed.
AUX HYDRAULICS ^a	Allows the operator to view parameters or do specific settings for hydraulic auxiliaries.
MACHINE SETTINGS	Provides a limited set of tools to setup various configurations and machine settings.
MACHINE FAN	Allows the operator to view actual fan speed and what sensor is controlling the fan speed. Allows the operator to manually adjust the fan reversal interval time.
ABOUT	Allows the operator to view hardware and software information for machine controllers.
SECURITY	Provides means for machine owner to assign PINs to authorized operators to prevent theft or unauthorized use of the machine. When security system is enabled, the operator must enter a valid PIN when prompted or the machine cannot be started.
CAMERA ^a	Allows the operator to adjust the video contrast.
SOFTWARE UPDATE ^b	Allows for machine controlled software to be updated remotely via JDLink™ cellular connection.

^aIf equipped.

^bThis menu is only applicable for machines equipped with JDLink.

JDLink is a trademark of Deere & Company

YN00108,0001BBA -19-15JUN20-1/1

Operation—Operating the Machine

Before Starting Work

Review the operating precautions. See **Safety—Operating Precautions (1-3)**.

Use seat belt when operating machine. Remember to fasten seat belt even during brief periods of use.

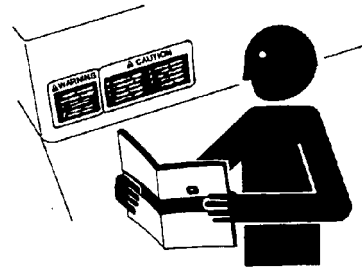

Reading Operator's Manual

TX,BEFORE,WORK -19-16MAY23-1/1

T133556 —UN—24AUG00

Inspect Machine Daily Before Starting

Perform daily maintenance checks. See **Maintenance—Every 10 Hours or Daily. (Section 3-4.)**

- Inspect the grille and radiator screen (3) for obstructions.
- Clean the hood perforation (4).
- Inspect the precleaner (2) (if equipped) and clean as necessary.
- Clean the operator's station (1), check the pedals for freedom of movement, and check the fire extinguisher charge (if equipped).
- Check the fuel level. Remove the fuel tank cap (6) and fill with proper fuel if necessary.
- Check the engine oil level.
- Check the engine coolant level.
- Check for active diagnostic trouble codes (DTCs) in the diagnostics menu of the display.

Inspect the following before starting:

ELECTRICAL SYSTEM—Check for worn or frayed wires and loose or corroded connections.

HYDRAULIC SYSTEM—Check for leaks, missing or loose clamps, kinked hoses, and lines or hoses that are making contact with each other or other machine parts.

FUEL SYSTEM—Check for leaks, missing or loose clamps, kinked hoses, drain water and sediment from primary and auxiliary fuel filters, and lines or hoses that are making contact with each other or other machine parts.

HARDWARE—Check for loose or missing parts.

LUBRICATION—Check lubrication points on periodic maintenance chart.

SHEET METAL AND TRACKS—Check for bent, broken, loose, or missing parts.

PROTECTIVE DEVICES—Inspect guards, shields, roll-over protective structure (ROPS), falling object protective structure (FOPS) (if equipped), and seat belt.

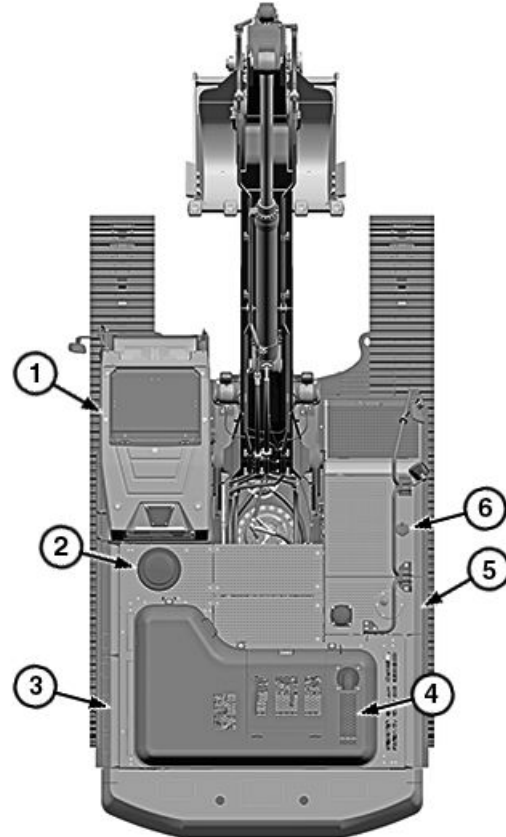

Daily Machine Inspection

- | | |
|-------------------------------|-----------------------|
| 1— Operator's Station | 4— Hood Perforation |
| 2— Precleaner (if equipped) | 5— Hydraulic Oil Tank |
| 3— Grille and Radiator Screen | 6— Fuel Tank Cap |

SAFETY—Walk around machine to be sure that all persons are away from machine area.

YN00108,0001959 -19-09OCT19-1/1

YN1286389 —UN—14OCT19

Light-Duty Towing Procedure

NOTE: Choose appropriately sized cable before light-duty towing. Use this procedure for short distances only. For long distance, see an authorized John Deere dealer.

IMPORTANT: Never tow the machine faster than 1 km/h (0.62 mph).

Tow the machine off-road to the nearest location where repair work can be done. Limit towing distance to 460 m (503 yd) maximum.

Permissible towing load is 10 500 N (2360 lbf) maximum. Always carry out towing operations within the maximum towing capacity.

When towing the machine, hold the wire cable level and direct it straight to the track frame.

The light-duty towing holes (1) are located on the front and rear lower frame of the machine.

1— Light-Duty Towing Hole (4 used)

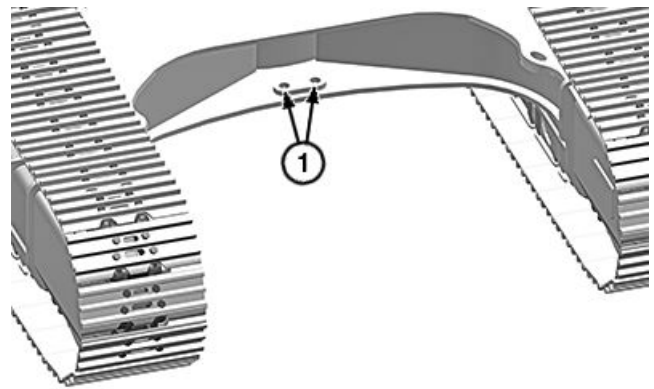

Light-Duty Towing Hole (view from front)

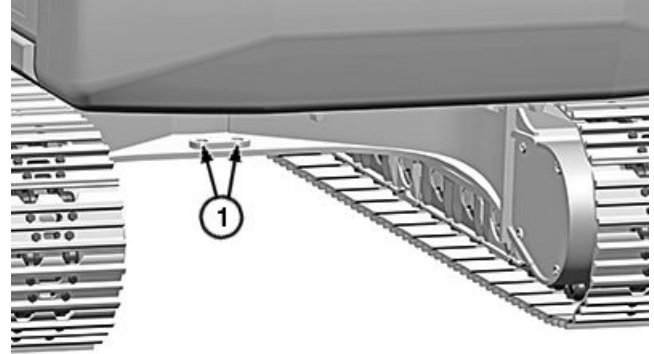

Light-Duty Towing Hole (view from rear)

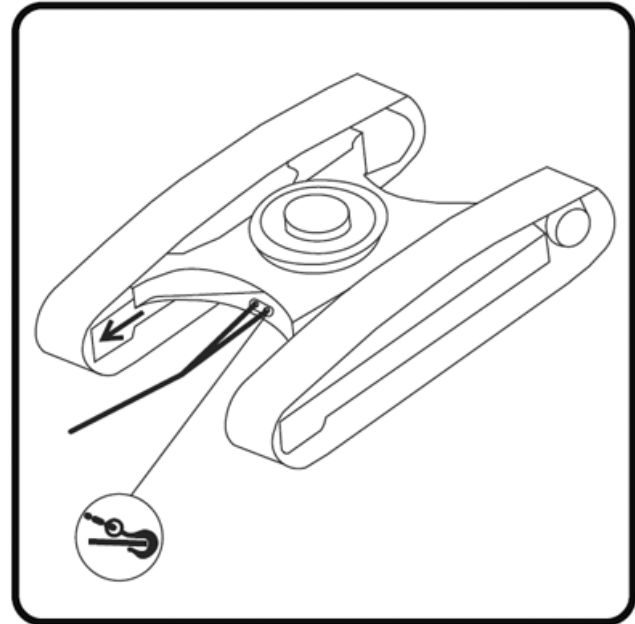

Towing Excavator

YN00108,000195C -19-11NOV19-1/1

YN1286439 —UN—06NOV19

YN1286440 —UN—06NOV19

TX1067265A —UN—04NOV09

Maintenance—Machine

Required Emission-Related Information

Service Provider

A repair shop or person of the owner's choosing may maintain, replace, or repair emission control devices and systems with original or equivalent replacement parts. However, warranty, recall, and all other services paid for by John Deere must be performed at an authorized John Deere service center.

DX,EMISSIONS,REQINFO -19-08DEC23-1/1

Diesel Fuel

Consult a local fuel distributor for properties of the diesel fuel available in the area.

In general, diesel fuels are blended to satisfy the low temperature requirements of the geographical area in which they are marketed.

Diesel fuels specified to EN 590 or ASTM D975 are recommended. Renewable diesel fuel produced by hydrotreating animal fats and vegetable oils is basically identical to petroleum diesel fuel. Renewable diesel fuel that meets EN 590 or ASTM D975 is acceptable for use at all percentage mixture levels.

Required Fuel Properties

In all cases, the fuel shall meet the following properties:

Cetane number of 43 minimum. Cetane number greater than 47 is preferred, especially for temperatures below -20°C (-4°F) or elevations above 1500 m (5000 ft).

Cold filter plugging point (CFPP) should be at least 5°C (9°F) below the expected lowest temperature or **Cloud Point** below the expected lowest ambient temperature.

Fuel lubricity should pass a maximum scar diameter of 0.52 mm as measured by ASTM D6079 or ISO 12156-1. A maximum scar diameter of 0.45 mm is preferred.

Diesel fuel quality and sulfur content must comply with all existing emissions regulations for the area in which the engine operates. **DO NOT** use diesel fuel with sulfur content greater than 10 000 mg/kg (10 000 ppm).

E-Diesel fuel

⚠ CAUTION: Avoid severe injury or death due to the fire and explosion risk from using E-Diesel fuel.

DO NOT use E-Diesel (Diesel fuel and ethanol blend).

Use of E-Diesel fuel in any John Deere machine may void the machine warranty.

Sulfur Content for Engines That Meet Interim Tier 4, Final Tier 4, Stage III B, Stage IV, and Stage V Engines

- Use **ONLY** ultra low sulfur diesel (ULSD) fuel with a maximum of 15 mg/kg (15 ppm) sulfur content.

Sulfur Content for Engines That Meet Tier 3 and Stage III A Engines

- Use of diesel fuel with sulfur content less than 2000 mg/kg (2000 ppm) is **RECOMMENDED**.
- Use of diesel fuel with sulfur content 2000—5000 mg/kg (2000—5000 ppm) **REDUCES** the oil and filter change interval.
- **BEFORE** using diesel fuel with sulfur content greater than 5000 mg/kg (5000 ppm), contact an authorized John Deere dealer.

Sulfur Content for Engines That Meet Tier 2 and Stage II Engines

- Use of diesel fuel with sulfur content less than 2000 mg/kg (2000 ppm) is **RECOMMENDED**.
- Use of diesel fuel with sulfur content 2000—5000 mg/kg (2000—5000 ppm) **REDUCES** the oil and filter change interval.
- **BEFORE** using diesel fuel with sulfur content greater than 5000 mg/kg (5000 ppm), contact an authorized John Deere dealer.

Sulfur Content for Other Engines

- Use of diesel fuel with sulfur content less than 5000 mg/kg (5000 ppm) is **RECOMMENDED**.
- Use of diesel fuel with sulfur content greater than 5000 mg/kg (5000 ppm) **REDUCES** the oil and filter change interval.

IMPORTANT: Do not mix used diesel engine oil or any other type of lubricating oil with diesel fuel.

Improper fuel additive usage may cause damage on fuel injection equipment of diesel engines.

TX,FUEL1,A -19-26OCT20-1/1

Diesel Engine Oil and Filter Service Interval for Operation at High Altitude—Stage III Engines

IMPORTANT: Diesel fuel sulfur content also affects engine oil and filter service intervals. See Engine Oil and Filter Service Intervals in this section to determine the appropriate service interval prior to performing high altitude recommendations.

To avoid excessive oil degradation and potential engine damage, reduce oil and filter service intervals to 50% of the original recommended values when operating engines at altitudes above **1675 m (5500 ft)**.

When machine operates at or above **1829 m (6000 ft)** elevation, sample engine oil every 100 hours.

Oil analysis may allow longer service intervals.

Use only approved oil types.

Example of Original Hours	Corresponding High Altitude Hours
125	60
150	75
175	85
200	100
250	125
275	135
300	150
350	175
375	185
400	200
500	250

XL90995,00003DF -19-04MAR19-1/1

CLICK HERE TO **DOWNLOAD** THE COMPLETE MANUAL

- Thank you very much for reading the preview of the manual.
- You can download the complete manual from: www.heydownloads.com by clicking the link below



- Please note: If there is no response to CLICKING the link, please download this PDF first and then click on it.

CLICK HERE TO **DOWNLOAD** THE COMPLETE MANUAL

Maintenance—Periodic Maintenance

<input type="checkbox"/> Replace cab fresh air and recirculating air filters	<input type="checkbox"/> Replace engine air filters and dust unloader valve
<input type="checkbox"/> Lubricate swing gear case bearing	
Every 2000 Hours	
<input type="checkbox"/> Replace hydraulic tank breather filter	<input type="checkbox"/> Replace hydraulic oil return filter ³
<input type="checkbox"/> Inspect and clean hydraulic pilot mesh filter	<input type="checkbox"/> Clean case drain screen fittings
<input type="checkbox"/> Inspect or replace engine fan/accessory drive belt	<input type="checkbox"/> Adjust engine valve clearance
³ For recommended change intervals, if using hydraulic hammer on machine, see Hydraulic Hammer Attachment. (Section 3-2.)	
Every 4000 Hours	
<input type="checkbox"/> Drain and refill hydraulic oil ⁴	<input type="checkbox"/> Clean hydraulic tank suction strainer
<input type="checkbox"/> Clean hydraulic tank magnetic plug	<input type="checkbox"/> Replace engine crankshaft damper
⁴ For recommended change intervals, see Hydraulic Oil. (Section 3-1.) If using hydraulic hammer on machine, see Hydraulic Hammer Attachment. (Section 3-2.)	
Every 6000 Hours	
<input type="checkbox"/> Drain and refill engine coolant	

XL90995,00019BF -19-17DEC19-2/2

Check Engine Coolant Level

1. Park machine on a level surface.
2. Stop engine.
3. To access surge tank (1), open the top service cover.
4. Check engine coolant level. With the engine cold, coolant level must be filled to the MAX COLD mark on the surge tank.
5. If coolant is below the MAX COLD mark, add coolant to the surge tank. See Drain and Refill Engine Coolant. (Section 3-12.)

CAUTION: Prevent possible injury from hot spraying water. **DO NOT** remove surge tank cap unless engine is cool. Unscrew cap slowly and release all pressure before removing cap.

IMPORTANT: Avoid mixing different brands or types of coolant. Coolant manufacturers engineer their coolants to meet certain specifications and performance requirements. Mixing different coolant types can degrade coolant and machine performance.

If surge tank is empty, check for leaks. Repair as required. Add coolant to the surge tank.

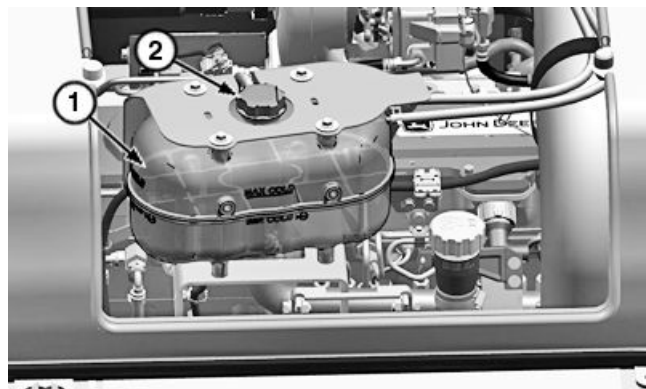

Surge Tank Location

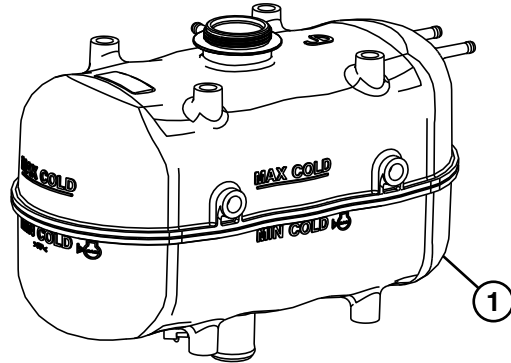

Surge Tank

1— Surge Tank

2— Surge Tank Cap

XL90995,00019BB -19-17DEC19-1/1

YN1285302 —UN—25SEP19

YN1285303 —UN—25SEP19

Replace Final Fuel Filter

1. Park machine on a level surface.
2. Stop engine.
3. Open right service door to access final fuel filter (1).
4. Thoroughly clean exterior of final fuel filter and surrounding area.
5. Shut off fuel. See Replace Auxiliary Fuel Filter. (Section 3-8.)

CAUTION: Prevent escaping fuel under pressure penetrate the skin and cause serious injury. Relieve pressure before removing filter.

6. Loosen the drain valve (2) to relieve pressure and drain contaminants. Close the drain valve. Dispose of waste properly. Disconnect the drain hose (3).
7. Turn the filter counterclockwise to remove. Dispose of used filter properly.
8. Clean filter mounting base.

IMPORTANT: Prevent fuel system damage. DO NOT prefill fuel filters. Debris in unfiltered fuel damages fuel system components.

Only lubricate filter seal with diesel fuel before installing.

9. Install new filter. Turn filter clockwise until gasket touches mounting surface and a “click” is heard.

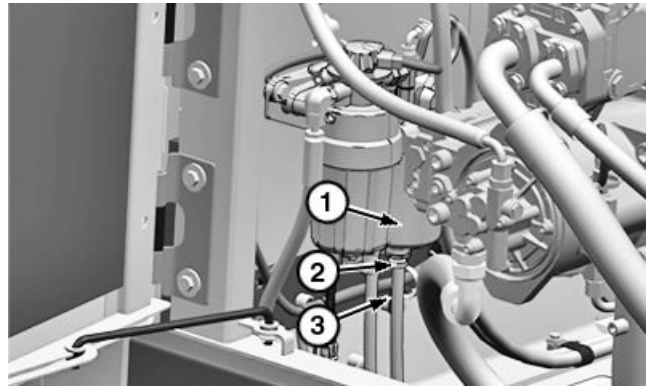

Final Fuel Filter

1— Final Fuel Filter
2— Drain Valve

3— Drain Hose

10. Install the drain hose.
11. Resume fuel flow. See Replace Auxiliary Fuel Filter. (Section 3-8.)
12. Prime fuel system and bleed air. See Bleed Fuel System. (Section 4-1.)
13. Operate engine and check for leaks.
14. Tighten filter element only enough to stop leaks.
15. Close the service door.

XL90995,00019BD -19-17DEC19-1/1

YN1285577 —UN—25SEP19

Inspect and Clean Hydraulic Pilot Mesh Filter



Machine Position

YN1163565—UN—18JUN14

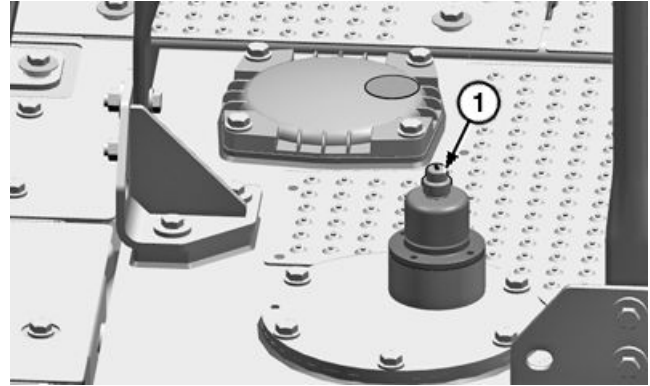

Pressure Release Button

YN1285613—UN—25SEP19

1. Park machine on a level surface. Fully retract bucket cylinder and arm cylinder. Lower boom to ground.
2. Stop engine.

CAUTION: High-pressure release of oil from pressurized system can cause serious burns or penetrating injury. The hydraulic tank is pressurized. Relieve pressure by pressing the pressure release button.

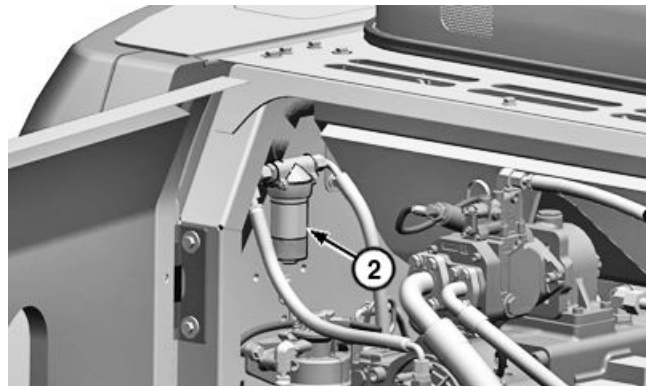

YN1285618—UN—25SEP19

3. To relieve hydraulic pressure, press the pressure release button (1) slowly.
4. To access pilot oil filter (2), open the right service door.
5. Thoroughly clean exterior of pilot oil filter and surrounding area.
6. Remove pilot oil filter by turning counterclockwise.
7. Remove the mesh (3) from the pilot oil filter. Inspect mesh for damage and clean the mesh with clean hydraulic oil.
8. Install the mesh back into the filter.
9. Clean the filter mounting base.
10. Install and tighten pilot oil filter clockwise.

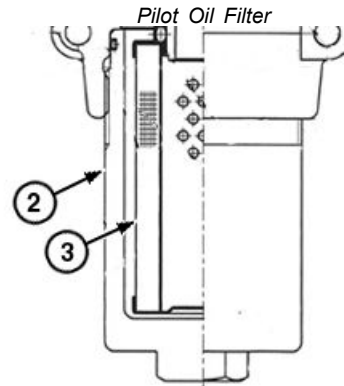

Pilot Mesh Filter

YN1285709—UN—25SEP19

Specification

Pilot Oil Filter—Torque.....	25—35 N·m
	18.4—25.8 lb·ft

- 1— Pressure Release Button 3— Mesh
2— Pilot Oil Filter

11. Close the service door.

XL90995,00018E9 -19-29OCT19-1/1

Clean Case Drain Screen Fittings

See an authorized John Deere dealer.

XL90995,0000440 -19-13MAY19-1/1

Precautions for Alternator and Regulator

When batteries are connected, follow these rules:

1. Disconnect negative (-) battery cable when working on or near alternator or regulator.
2. DO NOT TRY TO POLARIZE ALTERNATOR OR REGULATOR.
3. Be sure that alternator wires are correctly connected BEFORE connecting batteries.
4. Do not ground alternator output terminal.
5. Do not disconnect or connect any alternator or regulator wires while batteries are connected or while the alternator is operating.
6. Connect batteries or a booster battery in the correct polarity (positive [+] to positive [+] and negative [-] to negative [-]).
7. Do not disconnect the batteries when engine is running and alternator is charging.
8. Disconnect battery cables before connecting battery charger to the batteries. If machine has more than one battery, each battery must be charged separately.
9. Before washing machine, place a water repellent cover over the alternator.
10. To prevent component damage, the water jets need to be set at a 45-degree angle with reduced water pressure. Avoid direct contact with electrical and electronic connectors.

CED,OUO1021,185 -19-04MAR20-1/1

Store Batteries at Proper Temperature

When storing batteries, the temperature should not exceed -15°C (5°F) to 20°C (68°F) range. Store batteries in a cool, dry place.

XL90995,0001968 -19-09DEC19-1/1

1. Lower seat back. See Adjusting the Mechanical Suspension Seat or see Adjusting the Air Suspension Seat—If Equipped. (Section 2-1.)

2. Remove the cover (1) from cab back panel.

NOTE: The fuse decal is located inside of the fuse box cap.

3. Open fuse box (2) and replace fuses.

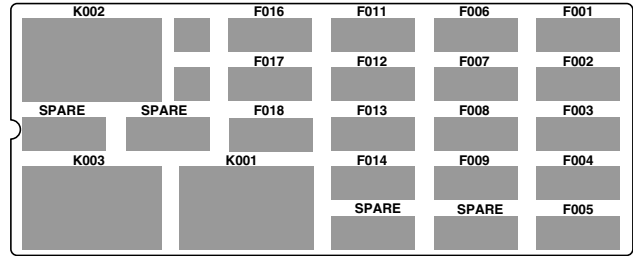

YN122775 —JN—22MAR17

Fuse Decal

Fuse No.	Function	Fuse Rating
F001	Cab Unswitched Power	10 A
F002	Primary Display Unit (PDU) Unswitched Power	10 A
F003	24 V Power Port	7.5 A
F004	Modular Telematics Gateway (MTG) Unswitched Power (if equipped)	5 A
F005	Sealed Switch Module (SSM) Unswitched Power	5 A
F006	Cab Control Unit (CAB) Switched Power	10 A
F007	Primary Display Unit (PDU) and Modular Telematics Gateway (MTG) Switched Power	10 A
F008	Cab Inputs	5 A
F009	Radio	5 A
F011	Heating and Air Conditioning System	20 A
F012	Premium Seat (if equipped)	10 A
F013	Upper Wiper	10 A
F014	12 V Power Port (if equipped)	5 A
F016	Dome Light	5 A
F017	Cab Front Work Lights (if equipped)	10 A
F018	Cab Rear Work Lights (if equipped)	10 A
K001	Cab Front Work Lights Relay (if equipped)	-
K002	Cab Rear Work Lights Relay (if equipped)	-
K003	Rotary Beacon Relay (if equipped)	-

Fuse Box Inside Cab

Continued on next page

YN00108.000193C -19-17SEP19-2/4

Check Air Intake Hose

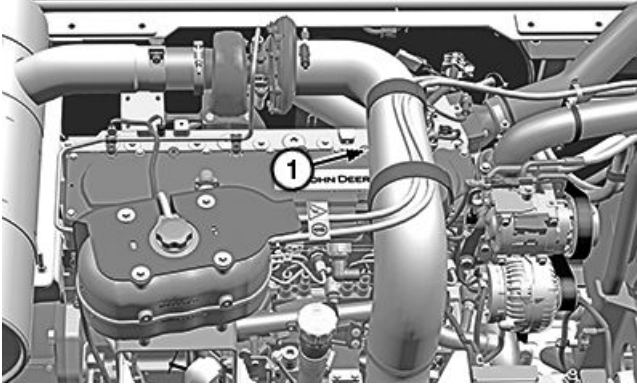

YN1286306—UN—08OCT19

Air Intake Hose (engine 6090HT023)

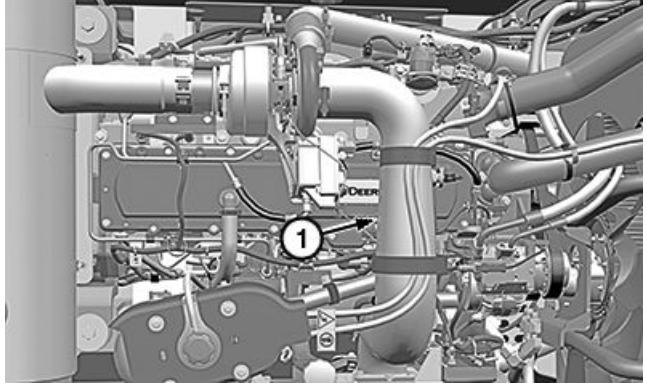

YN1286307—UN—08OCT19

Air Intake Hose (engine 6090HT026)

1. Check air intake hose (1) for cracks. Replace as necessary.
2. Check for loose connections. Tighten clamps as necessary.

1— Air Intake Hose

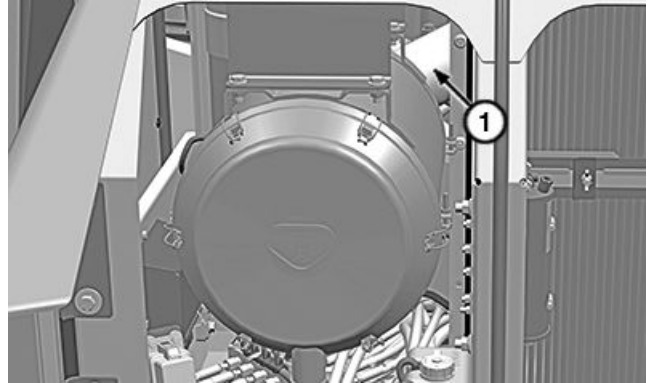

YN1286308—UN—08OCT19

Air Intake Hose

YN00108,0001953 -19-08OCT19-1/1

Miscellaneous—Operational Checkout

Operational Checkout Procedure

This procedure is used to check operation of machine. It is designed so technician can do a walk around inspection, check machine operation, and perform specific checks from the operator's seat.

If there is a problem with machine, diagnostic information in this checkout will help pinpoint the probable cause. This information may allow technician to perform a simple adjustment to correct the problem. Use the table of contents to help find adjustment procedures.

A location will be required which is level and has adequate space to complete checks. No tools or equipment are needed to perform checkout.

Complete necessary visual checks (oil levels, oil condition, external leaks, loose hardware, linkage, and wiring) prior to doing checkout. The machine must be at operating temperature for many of the checks. See an authorized John Deere dealer.

Read each check completely before performing. If no problem is found, go to the next check. If a problem is indicated, refer to a procedure for adjustment, repair, or replacement.

The monitor can be used to perform diagnostic and operational checks. The monitor can display engine speed, pressures, and diagnostic trouble codes (DTCs).

XL90995,0001936 -19-06DEC19-1/41

Diagnostic Trouble Codes (DTCs) Check

XL90995,0001936 -19-06DEC19-2/41

Display and Clear Diagnostic Trouble Codes

Always check for diagnostic trouble codes (DTCs) and correct them before performing the operational checkout.

Diagnostic trouble codes can be displayed by using one of the following methods:

- Primary display unit (PDU)
 - To access DTCs using PDU, see Menu—Diagnostics. (Section 2-2.)
- Service ADVISOR™ diagnostic application

LOOK: Are DTCs present?

YES: Correct DTCs.

NO: Proceed with operational checkout.

Service ADVISOR is a trademark of Deere & Company

XL90995,0001936 -19-06DEC19-3/41

Operational Checks—Ignition Off, Engine Off Checks

Continued on next page

XL90995,0001936 -19-06DEC19-4/41

Engine Start Speed Check

Engine OFF.

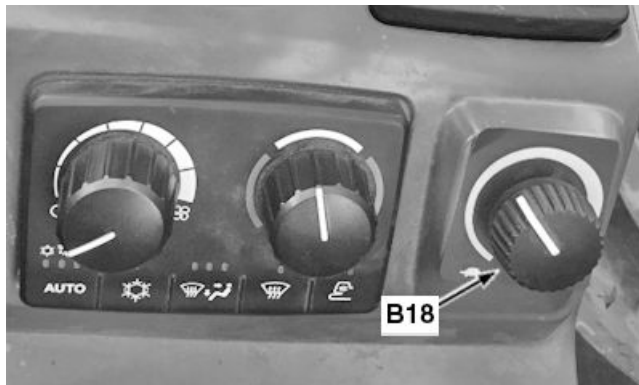

YN1284218 —UN—27AUG19

Engine Speed Control Dial

B18— Engine Speed Control Dial

Turn engine speed control dial (B18) to fast idle position (fully clockwise).

Start engine.

LOOK/LISTEN: Does engine start at slow idle?

Turn engine speed control dial to slow idle position (fully counterclockwise).

LOOK/LISTEN: Does engine continue to run at slow idle?

Turn engine speed control dial to fast idle position.

LOOK/LISTEN: Does engine speed increase as engine speed control dial is turned clockwise to fast idle position?

Stop engine.

YES: Go to next check.

NO: See an authorized John Deere dealer.

Continued on next page

XL90995,0001936 -19-06DEC19-16/41

- 1— Commanded Temperature
- 2— Air Conditioner
- 3— Outside Temperature
- 4— Air Source
- 5— Next Page Icon
- 6— Air Mode
- 7— Fan Speed

LOOK: Does PDU display commanded temperature (1)?

LOOK: Does PDU display fan speed (7), air conditioner (2), and air mode (6) in AUTO mode?

LISTEN/FEEL: Does fan turn on?

Press air conditioner manual switch (S23).

LOOK: Does first LED on ATC switch go off and LED on air conditioner manual switch illuminate?

LOOK: Does PDU display air conditioner in manual mode and do other displays stay in AUTO mode?

Press air conditioner manual switch again.

LOOK: Does air conditioner icon disappear?

Press air mode control switch (S24).

LOOK: Does second LED on ATC switch go off and third LED on air mode control switch illuminate?

LOOK: Does PDU display FACE air mode?

LOOK/FEEL: Does vent position change? Does air come out of corresponding vents?

Press air mode control switch for the second time.

LOOK: Does second and third LEDs on air mode control switch illuminate?

LOOK: Does PDU display FACE and FOOT air mode?

LOOK/FEEL: Does vent position change? Does air come out of corresponding vents?

Press air mode control switch for the third time.

LOOK: Does second LED on air mode control switch stay illuminated and third LED go off?

LOOK: Does PDU display FOOT air mode?

LOOK/FEEL: Does vent position change? Does air come out of corresponding vents?

Press air mode control switch for the fourth time.

LOOK: Does second LED on air mode control switch stay illuminated and first LED illuminate?

LOOK: Does PDU display FOOT and DEFROST air mode?

LOOK/FEEL: Does vent position change? Does air come out of corresponding vents?

Press air mode control switch for the fifth time.

LOOK: Does first LED on air mode control switch stay illuminated and second LED go off?

LOOK: Does PDU display DEFROST air mode?

LOOK/FEEL: Does vent position change? Does air come out of corresponding vents?

Press air mode control switch for the sixth time.

LOOK: Does third LED on air mode control switch illuminate and first LED go off?

LOOK: Does PDU go back to display FACE air mode?

LOOK/FEEL: Does vent position change? Does air come out of corresponding vents?

Press defrost mode switch (S25).

LOOK: Does LED on defrost mode switch illuminate?

Continued on next page

XL90995,0001936 -19-06DEC19-26/41

Travel System Tracks

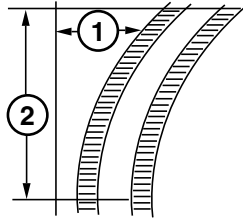

YN1284238 —UN—27AUG19

Travel Systems Tracks

- 1— Distance of Mistrack From Parallel
- 2— 20 m (66 ft)

Start engine.

Run at fast idle with high-power mode switch ON (LED illuminated).

CAUTION: Avoid crushing injury from unexpected machine movement. Make sure that machine is in adequate area to operate all hydraulic functions and is clear from all bystanders.

Move pilot enable lever to unlocked (up) position.

Travel speed set to slow (first LED illuminated).

Mark 20 m (66 ft) on flat surface.

Position machine to run parallel with line.

Travel machine full speed forward for 20 m (66 ft).

LOOK: Does machine mistrack more than specification?

Specification

Mistrack Distance From Line—Distance
 (maximum)..... 300 mm
 12 in

YES: See an authorized John Deere dealer.

NO: Go to next check.

Continued on next page

XL90995,0001936 -19-06DEC19-38/41

Electrical System

NOTE: If any other problems are encountered which require special tools or machine knowledge to correct, see an authorized John Deere dealer.

Symptom	Problem	Solution
No Electrical Functions	Batteries undercharged or dead	Charge or replace.
	Battery disconnect open	Check battery disconnect switch.
	Main circuit fuse open	Check battery power 125 A fuse (F201).
Batteries Undercharged	Loose or corroded connections	Clean and tighten or replace batteries.
	Alternator excitation loose or not installed	Check alternator excitation.
	Serpentine belt issue	Check serpentine belt.
Batteries Will Not Take a Charge	Loose or corroded connections	Clean and tighten or replace batteries.
	Alternator excitation loose or not installed	Check alternator excitation.
	Serpentine belt issue	Check serpentine belt.
	Weak batteries	Replace both batteries.
Cracked Battery Case	No battery hold-down clamp	Replace battery and install hold-down clamp.
	Loose battery hold-down clamp	Replace battery and tighten hold-down clamp.
	Frozen battery	Replace battery. Keep batteries fully charged in cold weather.
Low Battery Output	Dirty or wet battery top, causing discharge	Clean and wipe battery top dry.
	Corroded or loose battery cables	Clean and tighten battery cables.
	Alternator excitation loose or not installed	Check alternator excitation.
	Serpentine belt issue	Check serpentine belt.

Continued on next page

XL90995,00018DB -19-17SEP19-1/3

Machine Specifications

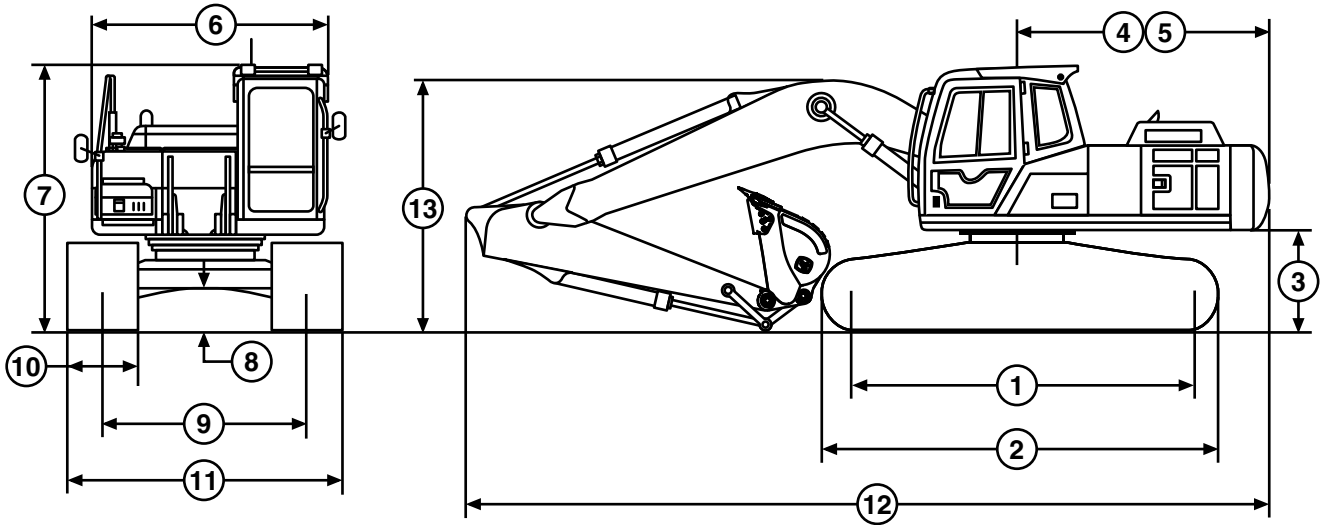

YN1284514

Overall Dimensions

- | | | | |
|------------------------------------|-----------------------------------|--------------------------------|------------------------------------|
| 1—Tumbler Distance | 4—Tail Length | 8—Ground Clearance | 12—Overall Length |
| 2—Overall Length of Crawler | 5—Tail Swing Radius | 9—Track Gauge | 13—Overall Height (to top of boom) |
| 3—Ground Clearance (counterweight) | 6—Overall Width of Upperstructure | 10—Track Shoe Width | |
| | 7—Overall Height (to top of cab) | 11—Overall Width (over tracks) | |

E380LC

NOTE: Specifications and design subject to change without notice. Wherever applicable, specifications are in accordance with PCSA, SAE, and ISO standards. Except where otherwise noted these

specifications are based on a machine equipped with 600 mm (24 in) shoes, counterweight, 6.45 m (21 ft 2 in) boom, 3.2 m (10 ft 6 in) arm, 1.6 m³ (2.1 yd³) bucket, full fuel tank, 75 kg (165 lb) operator, and standard equipment.

Item	Measurement	Specification
1—Tumbler	Distance	4230 mm 13 ft 10 in
2—Overall Length of Crawler	Length	5180 mm 16 ft 12 in
3—Ground Clearance (counterweight)	Height	1170 mm 3 ft 10 in
4—Tail	Length	3420 mm 11 ft 3 in
5—Tail Swing Radius	Distance	3500 mm 11 ft 6 in
6—Overall Width of Upperstructure	Width	2990 mm 9 ft 10 in
7—Overall Height (to top of cab)	Height	3180 mm 10 ft 5 in

Continued on next page

YN00108,0001D21 -19-30MAR21-1/3

YN1284514—UN—12SEP19

Miscellaneous—Specifications

6 m (19 ft 8 in)							10 860 kg (23 942 lb)	10 860 kg (23 942 lb)	9750 kg (21 495 lb)	8200 kg* (18 077 lb*)			9430 kg (20 789 lb)	6800 kg* (14 991 lb*)	8.29 m (27 ft 2 in)
4.5 m (14 ft 9 in)							12 110 kg (26 698 lb)	11 130 kg* (24 537 lb*)	10 270 kg (22 641 lb)	8030 kg* (17 703 lb*)			8830 kg* (19 467 lb*)	6150 kg* (13 558 lb*)	8.86 m (29 ft 1 in)
3 m (9 ft 10 in)							13 470 kg (29 696 lb)	10 670 kg* (23 523 lb*)	10 910 kg (24 052 lb)	7810 kg* (17 218 lb*)	8680 kg* (19 136 lb*)	6020 kg* (13 272 lb*)	8440 kg* (18 607 lb*)	5850 kg* (12 897 lb*)	9.15 m (30 ft 8 in)
1.5 m (4 ft 11 in)							14 390 0 kg (31 724 lb)	10 370 kg* (22 861 lb*)	11 230 kg* (24 758 lb*)	7640 kg* (16 843 lb*)	8650 kg* (19 070 lb*)	5970 kg* (13 161 lb*)	8430 kg* (18 585 lb*)	5820 kg* (12 831 lb*)	9.18 m (30 ft 0 in)
0					15 910 kg (35 075 lb)	15 780 kg* (34 789 lb*)	14 540 kg (32 055 lb)	10 290 kg* (22 685 lb*)	11 200 kg* (24 692 lb*)	7580 kg* (16 711 lb*)			8830 kg* (19 467 lb*)	6080 kg* (13 404 lb*)	8.97 m (29 ft 5 in)
-1.5 m (-4 ft 11 in)			10 960 kg (24 162 lb)	10 960 kg (24 162 lb)	17 880 kg (39 418 lb)	16 230 kg* (35 781 lb*)	13 820 kg (30 468 lb)	10 430 kg* (22 994 lb*)	10 810 kg (23 832 lb)	7670 kg* (16 909 lb*)			9160 kg (20 194 lb)	6710 kg* (14 793 lb*)	8.47 m (27 ft 9 in)
-3 m (-9 ft 10 in)			18 710 kg (41 248 lb)	18 710 kg (41 248 lb)	15 260 kg (33 642 lb)	15 260 kg (33 642 lb)	11 970 kg (26 389 lb)	10 770 kg* (23 744 lb*)					8740 kg (19 268 lb)	8040 kg* (17 725 lb*)	7.65 m (25 ft 1 in)
-4.5 m (-14 ft 9 in)			12 610 kg (27 800 lb)	12 610 kg (27 800 lb)	10 770 kg (23 743 lb)	10 770 kg (23 743 lb)	7660 kg (16 887 lb)	7660 kg (16 887 lb)					7420 kg (16 358 lb)	7420 kg (16 358 lb)	6.38 m (20 ft 11 in)
-6 m (-19 ft 8 in)															

NOTE: Lift capacities marked with * are limited by stability capacities.

Machine Handling Capacities Chart

LG70251,0001C8B -19-22NOV19-5/5

CLICK HERE TO **DOWNLOAD** THE COMPLETE MANUAL

- Thank you very much for reading the preview of the manual.
- You can download the complete manual from: www.heydownloads.com by clicking the link below



- Please note: If there is no response to CLICKING the link, please download this PDF first and then click on it.

CLICK HERE TO **DOWNLOAD** THE COMPLETE MANUAL