

# 850J Crawler Dozer

(Serial No. 130886 - )

## OPERATOR'S MANUAL

### 850J Crawler Dozer

OMT224252 ISSUE C9 (ENGLISH)

#### CALIFORNIA

#### Proposition 65 Warning

Diesel engine exhaust and some of its constituents are known to the State of California to cause cancer, birth defects, and other reproductive harm.

If this product contains a gasoline engine:

#### **WARNING**

The engine exhaust from this product contains chemicals known to the State of California to cause cancer, birth defects or other reproductive harm.

The State of California requires the above two warnings.

**Worldwide Construction  
And Forestry Division**  
LITHO IN U.S.A.

CLICK HERE TO **DOWNLOAD** THE COMPLETE MANUAL

- Thank you very much for reading the preview of the manual.
- You can download the complete manual from: [www.heydownloads.com](http://www.heydownloads.com) by clicking the link below



- Please note: If there is no response to CLICKING the link, please download this PDF first and then click on it.

CLICK HERE TO **DOWNLOAD** THE COMPLETE MANUAL

# Safety—Operator Convenience Features

## Safety and Operator Convenience Features

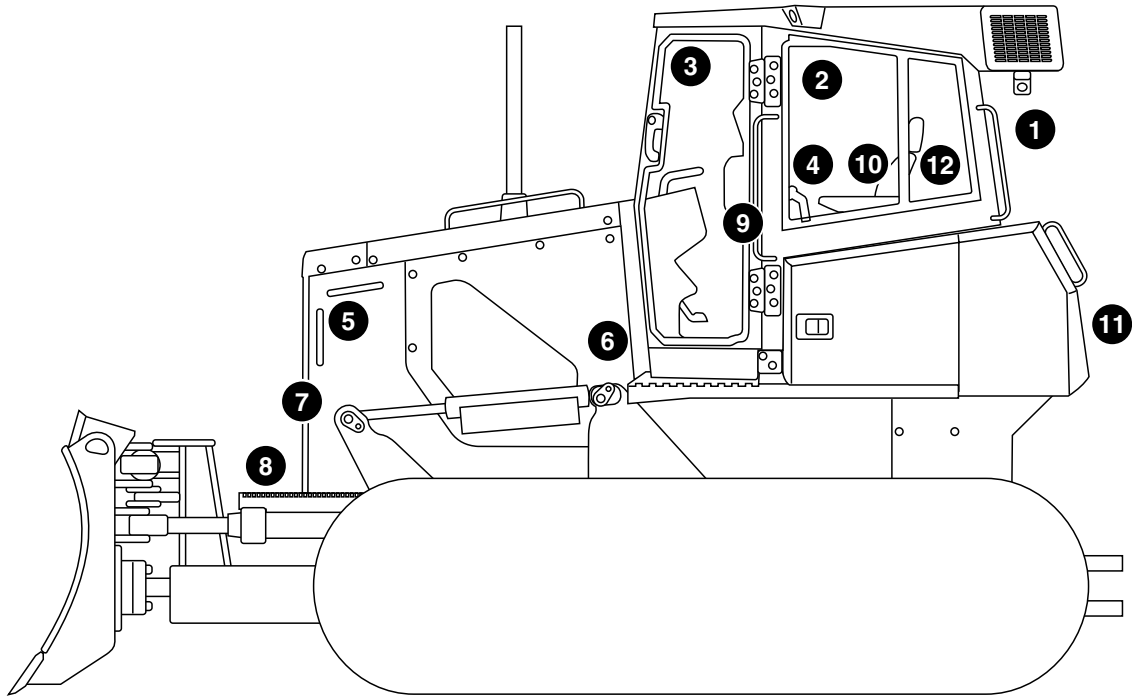

TX1052977

Please remember, the operator is the key to preventing accidents.

1. **ROPS, FOPS, and OPS.** Structures designed to help protect the operator are certified to ISO and OSHA. Enclosures also deflect sun and rain.
2. **Pressurized Cab.** Positive pressure ventilation system circulates both outside and inside air through filters for a clean working environment. Built-in defroster vents direct air flow for effective window defogging/deicing.
3. **Interior Rear View Mirror.** Offers the operator a view of activity behind him.
4. **Transmission Start.** After the park lock lever has been moved to the down (unlocked) position, the transmission control lever must have been in the neutral "N" position before the transmission is able to be engaged.
5. **Handholds.** Large conveniently placed handholds make it easy to enter or exit the operator's station.
6. **Bypass Start Protection.** Shielding over the starter solenoid helps prevent dangerous bypass starting.
7. **Engine Fan Guard.** A secondary fan guard inside engine compartment helps prevent contact with engine fan blades.
8. **Steps.** Wide skid-resistant steps help prevent slipping while getting in or out of the operator's station.
9. **Park Lock Start and Park Lock Lever.** Park lock start feature prevents the engine from being started unless the park lock lever is in the up (locked) position. When park lock lever is placed in "lock" position, the transmission shifts to neutral, the hydrostatic system is deactivated, and the park brake is engaged.
10. **Automatic Seat Belt Retractors.** Seat belt retractors help keep belts clean and convenient to use.
11. **Backup Alarm.** Alerts bystanders when reverse travel direction is selected by operator.
12. **Operator Manual Holder.** A sealed manual holder keeps manual on machine clean and dry.

JH91824,00002F9 -19-11DEC08-1/1

TX1052977 —UN—11DEC08

### Make Welding Repairs Safely

**IMPORTANT:** To avoid machine damage, disable electrical power before welding. Turn off main battery switch or disconnect positive battery cable. Separate harness connectors to engine and machine microprocessors.

Avoid welding or heating near pressurized fluid lines. Flammable spray may result and cause severe burns if pressurized lines fail as a result of heating. Do not let heat go beyond work area to nearby pressurized lines.

Remove paint properly. Do not inhale paint dust or fumes. Use a qualified welding technician for structural repairs.



T133547 —UN—31AUG00

Make sure there is good ventilation. Wear eye protection and protective equipment when welding.

TX03679,00016D5 -19-03NOV08-1/1

### Drive Metal Pins Safely

Always wear protective goggles or safety glasses and other protective equipment before striking hardened parts. Hammering hardened metal parts such as pins and bucket teeth may dislodge chips at high velocity.

Use a soft hammer or a brass bar between hammer and object to prevent chipping.

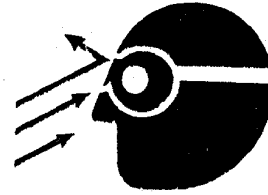

T133738 —UN—14SEP00

OJ01065,0000090 -19-03NOV08-1/1

### Cab Windows

Pull handle (1) forward and push out to open window.

1— Handle

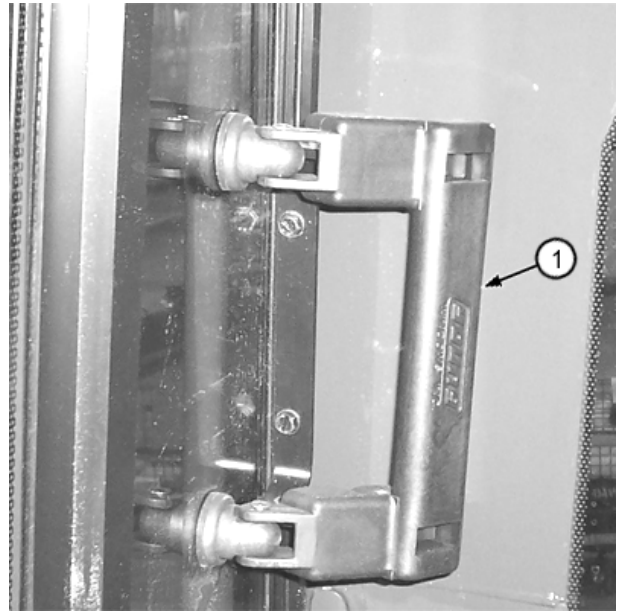

T206810A —UN—24JAN05

HG31779,0000062 -19-04DEC06-1/1

### Adjusting Seat

Use weight adjustment crank lever (E) to turn weight adjustment knob (F). Turn knob clockwise for firm ride and counterclockwise for soft ride.

Rotate knob (C) to desired cushion position.

Lift seat fore-and-aft lever (G) to move seat forward and rearward. Release handle at one of several positions.

Remove your weight from seat. Lift up handle (D) and move seat to one of three positions for height adjustment.

Move seat to mid-to-aft position. While sitting in seat, turn weight adjustment crank lever (E) to support weight. Check weight indicator (H) for appropriate weight setting and continue to turn until yellow pointer inside tube is flush with tube opening.

While sitting in seat, lift lever (B) and allow cushion to angle forward or lean backward into desired position and release handle.

While sitting in seat, rotate lumbar support knob (A) to increase or decrease support to lower back.

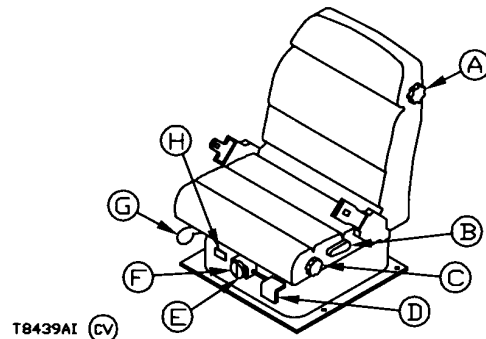

T8439AI —UN—22MAR95

- |  |  |
|--|--|
| <b>A—Lumbar Support Knob</b>                 | <b>E—Weight Adjustment Crank Lever</b> |
| <b>B—Back Cushion Angle Adjustment Lever</b> | <b>F—Weight Adjustment Knob</b>        |
| <b>C—Seat Cushion Adjustment Knob</b>        | <b>G—Fore-and-Aft Adjustment Lever</b> |
| <b>D—Seat Height Adjustment Lever</b>        | <b>H—Weight Indicator</b>              |

TX,10,RR,A33 -19-04DEC06-1/1

### Seat Belt

Seat belt and mounting hardware must be inspected for wear or damage before operating the machine. Replace the belt or mounting hardware if worn or damaged.

Replace the complete seat belt assembly every 3 years regardless of appearance.

TX,10,DH3548 -19-29APR08-1/1

## Decel/Brake Pedal and Decelerator Mode Switch

**⚠ CAUTION:** Prevent possible injury from unexpected machine movement. Pushing decel/brake pedal beyond a point of increased resistance will apply brakes and stop machine abruptly.

Do not apply brakes to stop machine during normal operating conditions. Pushing decel/brake pedal (1) beyond a point of increased resistance will apply brakes and stop machine abruptly.

The decelerator mode switch (2) is used to set operational mode of foot pedal. Two modes are available.

### Engine Mode

Actuating the decelerator mode switch to the “up” position will set the foot pedal in Engine Mode. In Engine Mode, pressing on the decelerator/brake pedal will slow engine rpm and reduce machine ground speed. Pushing pedal beyond a point of increase resistance will apply brakes and machine will stop abruptly. **Travel will resume as pedal is released.**

### Transmission Mode

Actuating the decelerator mode switch to the “down” position will set the foot pedal in Transmission Mode. In Transmission Mode, pressing on the decelerator/brake pedal will reduce machine ground speed but does not slow engine rpm. Pushing pedal beyond a point of increased resistance will apply brakes and machine will stop abruptly. **Travel will resume as pedal is released.**

**NOTE:** Decelerator mode switch position can be changed at any time. With Transmission Control Lever (TCL)

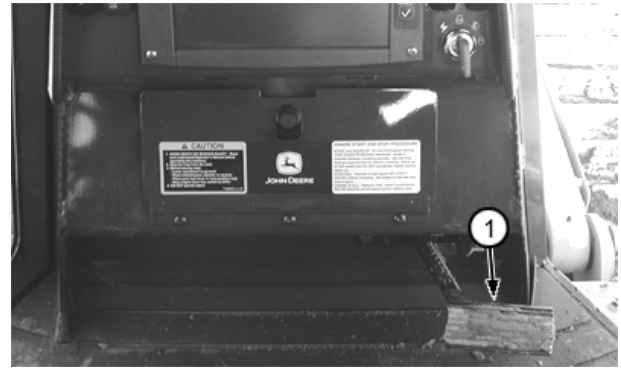

T198357A—UN—15MAR04

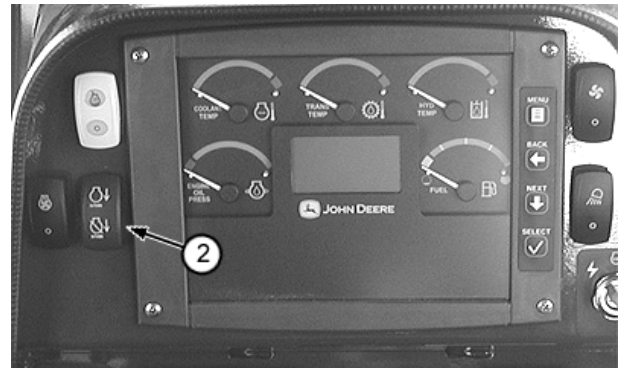

T207691A—UN—04FEB05

1— Decel/Brake Pedal

2— Decelerator Mode Switch

*in Neutral, mode change will take effect immediately. If TCL is not in Neutral, RTN to Neutral light will indicate TCL must be moved to Neutral for Decelerator Mode change to take effect.*

AM40430.0000037 -19-22FEB07-1/1

## Lifting the Machine

**CAUTION:** Avoid injury or machine damage from unexpected machine movement. Properly lift machine and use proper tie-downs.

**NOTE:** Do not use handles or steps in order to lift or tie down the machine.

For specific weight information, see Crawler Dozer Weights. (Section 4-6.)

1. Engage the parking brake.
2. Use proper rated cables and slings for lifting. The crane should be positioned so that the machine is lifted parallel to the ground.

Position the slings beneath the front of the track and beneath the rear of the track in designated lifting zones.

3. On sharp corners, use corner protectors.
4. To prevent contact with the machine, lifting cables should have sufficient length.
5. The width and strength of the spreader bar should be sufficient to prevent contact with the machine.

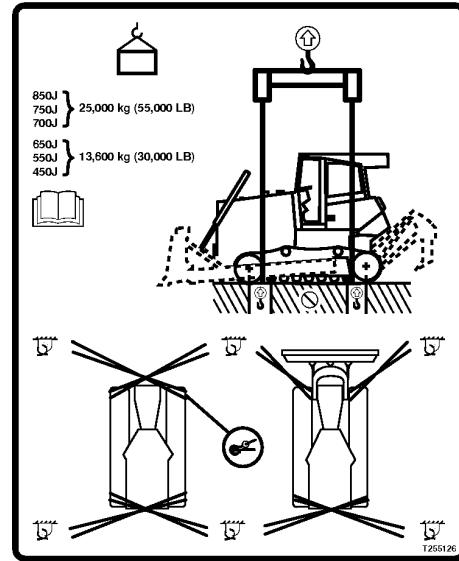

Lifting the Machine

TX1 053590 —JUN—07-JAN09

VD76477,00004A7 -19-23DEC08-1/1

# Maintenance—Machine

## Diesel Fuel

Consult your local fuel distributor for properties of the diesel fuel available in your area.

In general, diesel fuels are blended to satisfy the low temperature requirements of the geographical area in which they are marketed.

Diesel fuels specified to EN 590 or ASTM D975 are recommended. Renewable diesel fuel produced by hydrotreating animal fats and vegetable oils is basically identical to petroleum diesel fuel. Renewable diesel that meets EN 590 or ASTM D975 is acceptable for use at all percentage mixture levels.

### Required Fuel Properties

In all cases, the fuel shall meet the following properties:

**Cetane number of 45 minimum.** Cetane number greater than 50 is preferred, especially for temperatures below  $-20^{\circ}\text{C}$  ( $-4^{\circ}\text{F}$ ) or elevations above 1500 m (5000 ft).

**Cold Filter Plugging Point (CFPP)** should be at least  $5^{\circ}\text{C}$  ( $9^{\circ}\text{F}$ ) below the expected lowest temperature or **Cloud Point** below the expected lowest ambient temperature.

**Fuel lubricity** should pass a maximum scar diameter of 0.45 mm as measured by ASTM D6079 or ISO 12156-1.

### Sulfur Content for Interim Tier 4 and EU Stage IIIB Engines

- Diesel fuel quality and fuel sulfur content must comply with all existing emissions regulations for the area in which the engine operates.
- Use **ONLY** ultra low sulfur diesel (ULSD) fuel with a maximum of 0.0015% (15 ppm) sulfur content.

### Sulfur Content for Other Engines

- Diesel fuel quality and fuel sulfur content must comply with all existing emissions regulations for the area in which the engine operates.
- Use of diesel fuel with sulfur content less than 0.10% (1000 ppm) is **STRONGLY** recommended.
- Use of diesel fuel with sulfur content 0.10% (1000 ppm) to 0.50% (5000 ppm) may result in **REDUCED** oil and filter change intervals as shown in the table.
- **BEFORE** using diesel fuel with sulfur content greater than 0.50% (5000 ppm), contact your John Deere dealer.

**IMPORTANT: Do not mix used diesel engine oil or any other type of lubricating oil with diesel fuel.**

**Improper fuel additive usage may cause damage on fuel injection equipment of diesel engines.**

DX,FUEL1 -19-03NOV08-1/1

## Lubricity of Diesel Fuel

Most diesel fuels manufactured in the United States, Canada, and the European Union have adequate lubricity to ensure proper operation and durability of fuel injection system components. However, diesel fuels manufactured in some areas of the world may lack the necessary lubricity.

**IMPORTANT: Make sure the diesel fuel used in your machine demonstrates good lubricity characteristics.**

Fuel lubricity should pass a maximum scar diameter of 0.45 mm as measured by ASTM D6079 or ISO 12156-1.

If fuel of low or unknown lubricity is used, add John Deere **PREMIUM DIESEL FUEL CONDITIONER** (or equivalent) at the specified concentration.

### Lubricity of Biodiesel Fuel

Significant improvement in lubricity can occur with biodiesel blends up to B20. The gain in lubricity above a 20% blend is limited.

DX,FUEL5 -19-05OCT07-1/1

## Drain Intervals for Diesel Engine Coolant

Drain and flush the cooling system and refill with fresh coolant at the indicated interval, which varies with the coolant used.

John Deere COOL-GARD™ II Premix and COOL-GARD II Concentrate are maintenance free coolants for up to 6 years or 6000 hours of operation, provided that the cooling system is topped off using only John Deere COOL-GARD II Premix. Test the coolant condition annually with Coolant Test Strips designed for use with John Deere COOL-GARD II coolants. If the test strip chart indicates that additive is required, add John Deere COOL-GARD II COOLANT EXTENDER as directed.

When John Deere COOL-GARD Premix, COOL-GARD Concentrate or John Deere COOL-GARD PG Premix coolants are used, the drain interval may be extended to 5 years or 5000 hours of operation, provided that the coolant is tested annually AND additives are replenished, as needed, by adding a supplemental coolant additive.

If John Deere COOL-GARD II Premix or COOL-GARD II Concentrate is used, but the coolant is not tested OR

*COOL-GARD is a trademark of Deere & Company*

additives are not replenished by adding John Deere COOL-GARD II COOLANT EXTENDER, the drain interval is 4 years or 4000 hours of operation. This drain interval only applies to COOL-GARD II coolants that have been maintained within a 40% to 60% mixture of concentrate with quality water.

If John Deere COOL-GARD Premix, COOL-GARD Concentrate, or COOL-GARD PG Premix is used, but the coolant is not tested OR additives are not replenished by adding a supplemental coolant additive, the drain interval is 3 years or 3000 hours of operation. This drain interval only applies to COOL-GARD Premix, COOL-GARD Concentrate, and COOL-GARD PG Premix that have been maintained within a 40% to 60% mixture of concentrate with quality water.

If a coolant other than COOL-GARD II, COOL-GARD, or COOL-GARD PG is used, reduce the drain interval to 2 years or 2000 hours of operation.

DX,COOL11 -19-03NOV08-1/1

## John Deere COOL-GARD™ II COOLANT EXTENDER

Some coolant additives will gradually deplete during engine operation. For John Deere COOL-GARD™ II Premix and COOL-GARD II Concentrate, replenish coolant additives between drain intervals by adding John Deere COOL-GARD II COOLANT EXTENDER.

John Deere COOL-GARD II COOLANT EXTENDER should not be added unless indicated by coolant testing.

John Deere COOL-GARD II COOLANT EXTENDER is a chemically matched additive system approved for use with John Deere COOL-GARD II coolants in all John Deere engines.

John Deere COOL-GARD II COOLANT EXTENDER is not designed for use with John Deere COOL-GARD coolants.

*COOL-GARD is a trademark of Deere & Company*

**IMPORTANT: Do not add a supplemental coolant additive when the cooling system is drained and refilled with any of the following:**

- John Deere COOL-GARD II
- John Deere COOL-GARD
- John Deere COOL-GARD PG

The use of non-recommended supplemental coolant additives may result in additive drop-out, gelation of the coolant, or corrosion of cooling system components.

Add the recommended concentration of John Deere COOL-GARD II COOLANT EXTENDER. DO NOT add more than the recommended amount.

DX,COOL16 -19-03NOV08-1/1

## Maintenance and Repair Record Keeping System

The checklist in this chapter summarizes scheduled maintenance, and parts and oil required at each maintenance interval.

Use the checklist to:

- remind you to perform machine maintenance at specified intervals to minimize downtime.
- calculate cost of machine operation and ownership, allowing you to make better job estimates.
- place yourself in a stronger position at trade-in time.
- satisfy your SECURE contract requirements.

As maintenance is performed, check off each item on the list and record date and hour meter reading. Use the second (perforated) copy of this form (inside the back cover).

Do not tear out or mark on checklist in this chapter; keep it to make extra copies.



MAINTENANCE and REPAIR RECORD KEEPING SYSTEM FOR JOHN DEERE MACHINE OWNERS

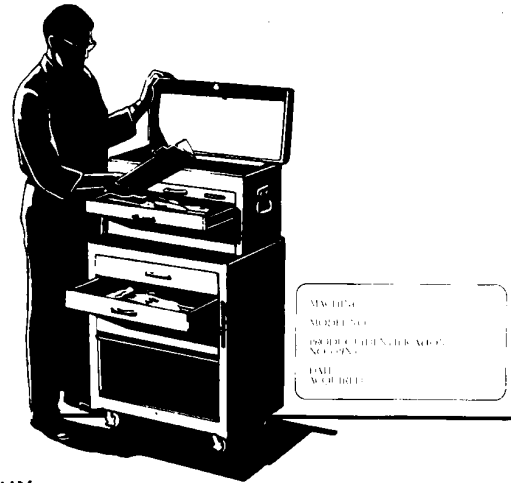

XX

T6828AA—19—03APR89

03T,50,K67 -19-04DEC06-1/1

## Fluid Analysis Program Test Kits and 3-Way Coolant Test Kit

Fluid Analysis Program Test Kits and the 3-Way Coolant Test Kit are John Deere fluid sampling products to help you monitor machine maintenance and system condition. The objective of a fluid sampling program is to ensure machine availability when you need it and to reduce repair costs by identifying potential problems before they become critical.

Engine, hydraulic, power train, and coolant samples should be taken from each system on a periodic basis, usually prior to a filter and/or fluid change interval. Certain systems require more frequent sampling. Consult your authorized John Deere dealer on a maintenance program for your specific application. Your authorized John Deere dealer has the sampling products and expertise to assist



you in lowering your overall operating costs through fluid sampling.

TX1003513A—UN—20FEB06

AM40430,00002FE -19-12DEC08-1/1

**⚠ CAUTION: Prevent injury from hot spraying coolant. Do not remove radiator filler cap unless engine is cool. Loosen cap slowly to the stop. Release all pressure before removing cap.**

1. With the engine cold, coolant level must be between HOT and COLD marks on recovery tank (1).
2. If coolant is below the COLD mark, add coolant to the recovery tank.
3. If there is no coolant in the recovery tank, add coolant to the recovery tank and the radiator.

1— Recovery Tank

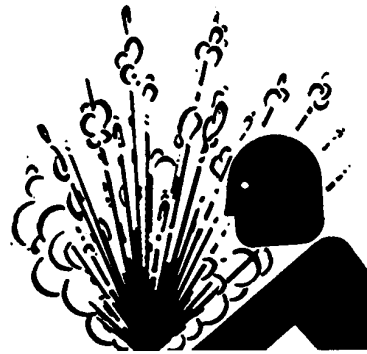

Avoid Hot Spraying Coolant

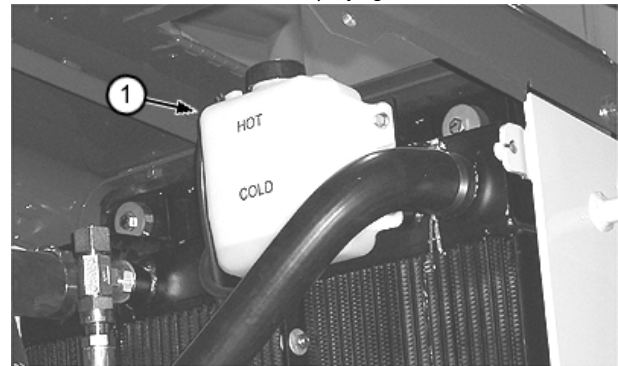

8.1 L Tier 2/Stage II Engine Recovery Tank Shown

T6464AV —UN—18OCT88

T206632A —UN—06JAN05

TF44157,0000BD8 -19-22DEC08-2/2

### Check Transmission Oil Level

**IMPORTANT: DO NOT operate engine without oil in reservoir.**

1. Park machine on level ground.
2. Turn key switch to OFF.
3. The transmission oil reservoir, fill port, and sight glass are located on the left side of the machine. Oil must be within the ADD mark and FULL mark on sight glass tube (1).
4. If necessary, add oil to fill port (2). See Transmission and Hydraulic Reservoir Oil. (Section 3-1.)
5. Check O-ring on cap before installing.

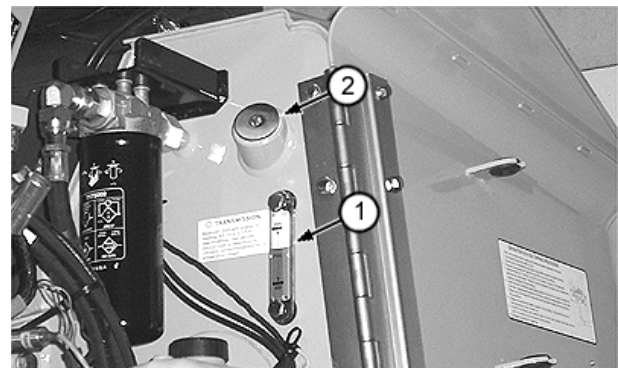

1— Sight Glass Tube

2— Fill Port

T206638A —UN—05JAN05

CS33148,000094F -19-04DEC06-1/1

**Remove and Install Final Fuel Filter Element**

1. Thoroughly clean filter header (2) and surrounding area to keep from getting dirt and debris into fuel system.
2. Connect a fuel drain line to filter drain valve (5) on bottom of filter and drain all fuel from the filter (4).
3. Turn filter counterclockwise to remove.
4. Inspect filter header sealing surfaces. Clean as required.
5. Install new fuel filter drain valve and tighten to specification.

**Specification**

Final Fuel Filter Drain Valve—Torque..... 3.4—4.0 N·m (30—35 lb-in.)

**IMPORTANT: Do not pre-fill filter with fuel. This may introduce debris into the fuel system.**

6. Place new filter packing (3) on filter.
7. Place a thin film of fuel on packing.
8. Screw fuel filter into fuel filter header, turning clockwise. Tighten until fuel filter snugly mates with fuel filter header (2).
9. Turn filter 1/2 to 3/4 turn further clockwise.
10. Bleed fuel system. See Bleeding Fuel System. (Section 4-1.)

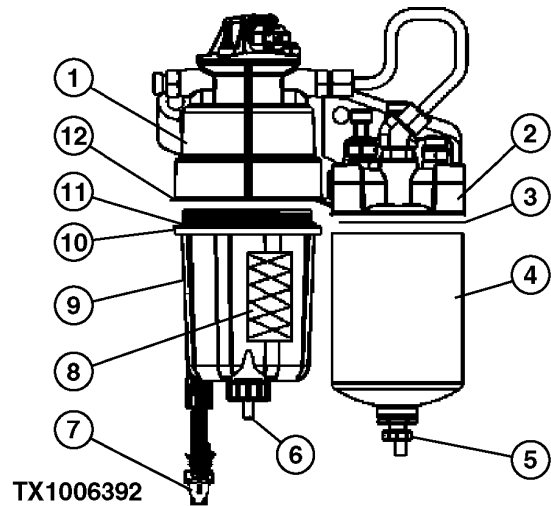

- |  |                                   |
|--|-----------------------------------|
| 1— Primary Filter Header               | 7— Water-In-Fuel Sensor Connector |
| 2— Final Fuel Filter Header            | 8— Primary Filter Element         |
| 3— Final Filter Packing                | 9— Primary Filter Canister        |
| 4— Final Fuel Filter                   | 10— Primary Filter Canister Lip   |
| 5— Final Filter Drain Valve            | 11— Primary Filter Packing        |
| 6— Primary Filter Canister Drain Valve | 12— Primary Filter Header Lip     |

TX1006392 —UN—18APR06

OUO1089,0002992 -19-04DEC06-2/2

CLICK HERE TO **DOWNLOAD** THE COMPLETE MANUAL

- Thank you very much for reading the preview of the manual.
- You can download the complete manual from: [www.heydownloads.com](http://www.heydownloads.com) by clicking the link below



- Please note: If there is no response to CLICKING the link, please download this PDF first and then click on it.

CLICK HERE TO **DOWNLOAD** THE COMPLETE MANUAL

## Change Hydrostatic Transmission Oil and Replace Hydrostatic Charge and Fan Oil Filters

**IMPORTANT:** Replace filter before recommended service interval if hydraulic oil filter indicator stays on after oil is warm.

1. Open left rear access door.
2. Loosen filler plug (1) to relieve pressure.
3. Remove rear access panel (2) below fuel tank.

*NOTE: Dispose of waste oil properly.*

4. Drain oil into container through environmental drain hose.
5. Clean area around housing and remove fan oil filter (3) by turning counterclockwise.
6. Apply a film of oil to sealing ring on new filter. Install so gasket touches mounting surface and tighten an additional 3/4 to one turn with a suitable wrench.
7. Clean area around housing and remove charge filter (4) by turning counterclockwise.
8. Apply a film of oil to sealing ring on new filter. Install so gasket touches mounting surface and tighten an additional 3/4 to one turn with a suitable wrench.
9. Fill reservoir with oil to specification and install plug.

### Specification

Hydrostatic System	
Oil—Capacity.....	105.6 L 27.9 gal

10. Move transmission control lever to neutral. Start engine and run at slow idle for five minutes before operating machine. This will allow filter element to refill and air to be purged from charge circuit.

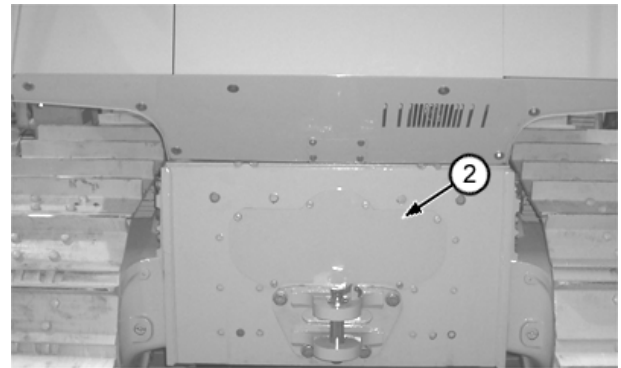
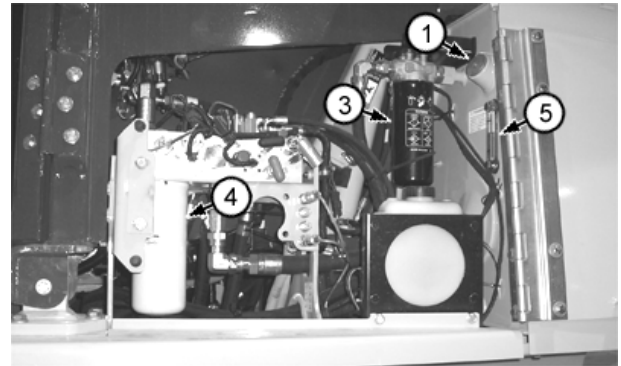

1— Filler Plug  
2— Rear Access Panel  
3— Fan Oil Filter

4— Charge Filter  
5— Sight Glass

11. Check for any leakage around element and tighten as necessary to stop leakage.
12. Check oil level in sight glass (5). Oil should be to midpoint.

CS33148,0000955 -19-04DEC06-1/1

T207457A —UN—26JAN05

T207253A —UN—25JAN05

## Adjust Engine Valve Lash

See your authorized dealer.

CS33148,0000956 -19-04DEC06-1/1

### Do Not Service or Adjust Injection Nozzles or Injection Pump

If injection nozzles are not working correctly or are dirty, the engine will not run normally. See your authorized dealer for service.

Changing the injection pump in any way not approved by the manufacturer will end the warranty. See your copy of the John Deere warranty on this machine.

Do not service an injection pump that is not operating correctly. See your authorized injection pump service center.

TX,90,FF3116 -19-03NOV08-1/1

### Clean Dust Unloader Valve

**IMPORTANT: A missing, damaged, or hardened dust unloader valve will make dust cup precleaner ineffective, causing very short element life. Valve should suck closed above 1/3 engine speed.**

Squeeze dust unloader valve (1) to remove dust from air cleaner.

If operating in high dust conditions, squeeze dust valve every couple of hours of operation to release dust.

1— Dust Unloader Valve



Dust Unloader Valve—9.0 L Tier 3 /Stage III A Engine

TX1006699A —UN—19APR06

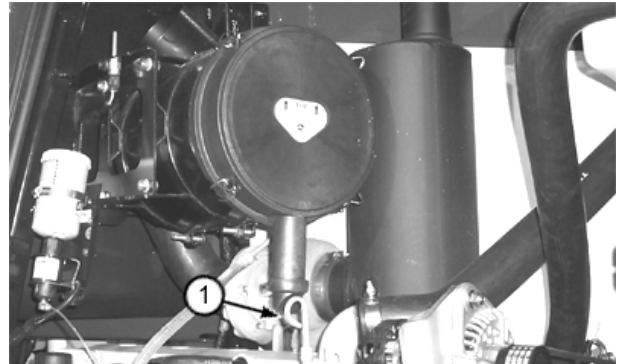

Dust Unloader Valve—8.1 L Tier 2 /Stage II Engine

T207198B —UN—25JAN05

CP94658,000015D -19-12DEC08-1/1

**JDLink™ In-Line Fuse (If equipped)**

1. Turn machine off.
2. On right side of operator's cab, remove four cap screws, and lift off fuse plate cover (2) to access the 5 amp JDLink™ unswitched power in-line fuse (1).

*NOTE: JDLink™ unswitched power in-line fuse (F33) will be labeled with a tag.*

3. To deactivate the JDLink™ Machine Monitoring System, remove the unswitched power in-line fuse.
4. Install fuse plate cover and cap screws.

*NOTE: The following items are located outside of the VEC:*

- IGC Fuse and Relay Box (IGC Machines Only)
- F32—Fuel Transfer Pump 15-Amp Fuse
- F33—Main 125-Amp Fuse (later machines)

*The fuel transfer pump 15-amp fuse (F32) is located in the right engine compartment just above the fuel transfer pump.*

*The main 125-amp fuse (F33) and IGC fuse and relay box (if equipped with integrated grade control) are located in the battery compartment.*

- 1— JDLink™ Unswitched Power In-Line Fuse (5 amp)      2— Fuse Plate Cover

- |  |  |
|--|--|
| F101— IGC Switched Power 15-Amp Fuse     | F105— IGC Unswitched Power_2 10-Amp Fuse |
| F102— BCJ Switched Power 5-Amp Fuse      | F106— IGC Unswitched Power_3 10-Amp Fuse |
| F103— EHC Switched Power 10-Amp Fuse     | K101— IGC Switched Power Relay           |
| F104— IGC Unswitched Power_1 10-Amp Fuse | K102— BCJ and EHC Switched Power Relay   |

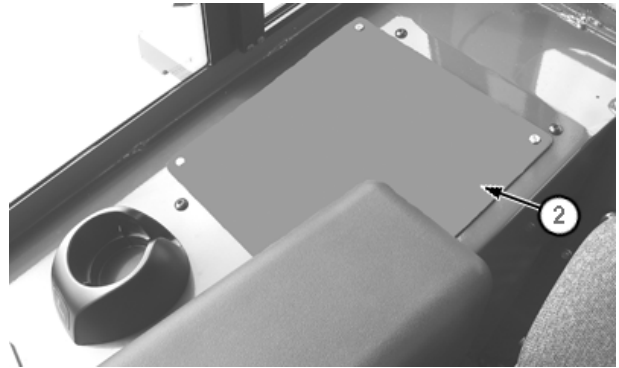

TX1025689A —UN—26JUN07

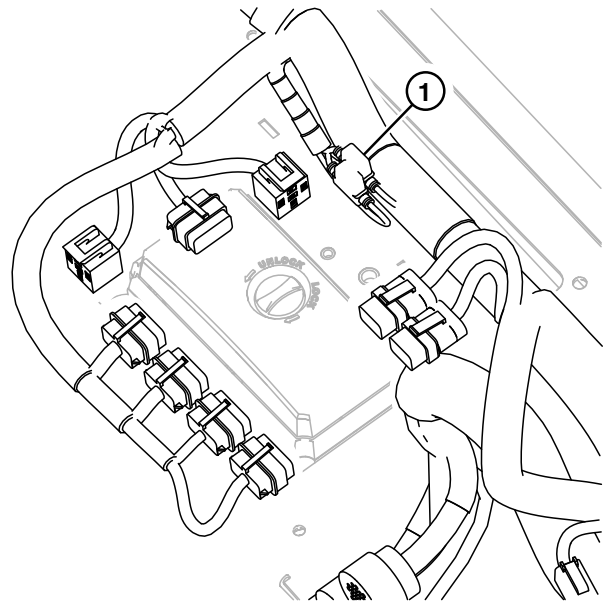

TX1025359 —UN—26JUN07

### Checking Park Lock Start System

**CAUTION:** Avoid possible injury or death. Be sure all people are away from machine when park lock start checks are performed.

1. Place transmission control lever (TCL) in neutral "N" position.
2. Move park lock lever (1) to down (unlocked) position.
3. Turn key switch to start position. Starter must not engage. If engine starts, return park lock lever to up (locked) position and see your John Deere dealer.
4. Move park lock lever to up (locked) position.
5. Turn key switch to start position. Starter should engage, turning engine over. If engine does not turn over, see your John Deere dealer.

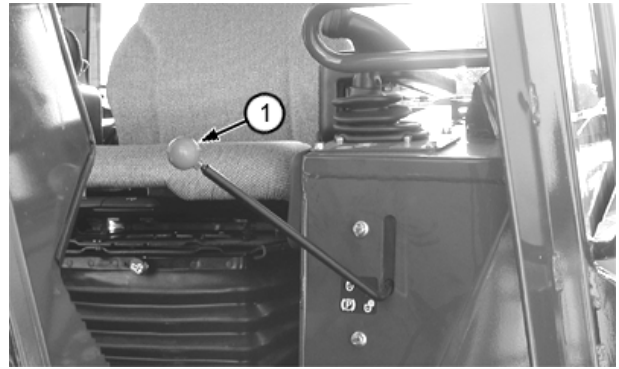

T198353A—UN—18JAN05

1— Park Lock Lever (Unlocked Position)

HG31779,000006E -19-04DEC06-1/1

### Checking Transmission Start System

**CAUTION:** Avoid possible injury or death. Be sure all people are away from machine when park lock start checks are performed.

1. With engine running on a level surface, place park lock lever in up (locked) position.
2. Move transmission control lever (TCL) to forward "F" or reverse "R" position.
3. Move throttle to 1500 rpm position.
4. Move park lock lever to down (unlocked) position.
5. Monitor should display "Return to N" and machine should not move.
6. Move TCL to neutral "N" position and "Return to N" light should turn off on monitor.

AM40430,0000033 -19-19SEP08-1/1

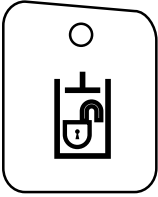
<p><b>Hydraulic Enable Circuit Check</b></p>	 <p>T194312 —UN—11SEP03 Run machine at idle. Push hydraulic enable switch to the LOCKED position to disable the hydraulic controls. Move blade control lever to all positions.  <i>LOOK: Do any blade functions operate?</i></p>	<p><b>YES:</b> See your authorized dealer. <b>NO:</b> Continue check.</p>
	<p>Push hydraulic enable switch to the UNLOCKED position to enable the hydraulic controls. Move blade control lever to all positions. <i>LOOK: Do all blade functions operate?</i></p>	<p><b>YES:</b> Check complete. <b>NO:</b> See your authorized dealer.</p>

VD76477,0001355 -19-23DEC08-23/39

<p><b>Blade Float Check Pilot Controls</b></p>	<p>Raise front of crawler off ground using blade hydraulics. Push blade control lever into float detent. <i>LOOK: Does front of crawler lower to ground?</i> <i>FEEL: Does blade control lever stay in float detent position?</i></p>	<p><b>YES:</b> Check complete. <b>NO:</b> See your authorized dealer.</p>
--	---	---

VD76477,0001355 -19-23DEC08-24/39

<p><b>Blade Float Check IGC Controls</b></p>	<p>Raise front of crawler off ground using blade hydraulics. Push blade control lever into float detent. <i>LOOK: Does front of crawler lower to ground?</i> <i>FEEL: Does blade control lever return to neutral when released?</i></p>	<p><b>YES:</b> Check complete. <b>NO:</b> See your authorized dealer.</p>
--	---	---

VD76477,0001355 -19-23DEC08-25/39

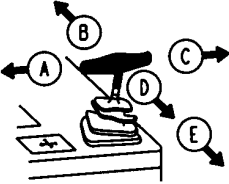
<p><b>Blade Control Lever Check</b></p>	 <p><b>A—Blade Tilt Right</b> <b>B—Blade Lift</b> <b>C—Blade Tilt Left</b> <b>D—Blade Down</b> <b>E—Blade Float</b></p> <p>Move control lever to each position (A—D) and release. <i>LOOK/FEEL: Does blade control lever move to all positions easily and return to neutral when released?</i> <i>NOTE: Blade control lever will not return to neutral when moved to blade float position (E) on non-IGC machines. Lever must be manually pulled from float position.</i></p>	<p><b>YES:</b> Check complete. <b>NO:</b> See your authorized dealer.</p>
---	--	---

Continued on next page

VD76477,0001355 -19-23DEC08-26/39

Symptom	Problem	Solution
<b>Engine Emits Excessive Black or Gray Exhaust Smoke</b>	Incorrect camshaft timing	Check timing. See your authorized dealer.
	Injection pump	Remove and test pump. See your authorized dealer.
	Restricted air filter	Check air filter restriction indicator and air filters. See Maintenance—As Required chapter. Replace.
	Incorrect grade of fuel	Drain fuel tank and add correct fuel. See Fuels and Lubricants chapter.
	Air leak between turbocharger and manifold	Test air intake system for leaks. See your authorized dealer.
	Excessive fuel delivery	Remove and test fuel injection pump. See your authorized dealer.
	Injection nozzles	Remove and test nozzles. See your authorized dealer.
<b>Engine Emits Excessive Blue or White Smoke</b>	Turbocharger	Remove air intake hose and exhaust elbow. Leading edge of compressor vanes must be sharp and straight. Spin compressor wheel and listen for noisy bearings. Turbine and compressor wheels must not rub in housing.
	Cranking speed too slow	Check batteries and connections.
	Incorrect grade of fuel	Drain fuel tank and add correct fuel. See Fuel and Lubricants chapter.
	Engine running too cold	Check thermostats. See your authorized dealer.
	Injection nozzles	Remove and test nozzles. See your authorized dealer.
	Low compression	Disconnect fuel injection pump solenoid wire connector. Crank engine and listen for air leaking past valves. Start engine and observe blow-by from vent tube. See your authorized dealer.
	Excessive wear in liners and/or piston rings stuck	Inspect and repair. See your authorized dealer.
Worn valve guides	Inspect and repair. See your authorized dealer.	

Continued on next page

OUC1089,00029A2 -19-04DEC06-4/8

Symptom	Problem	Solution
	Low oil level	Stop engine. Check level.
	Low oil viscosity	Drain and add correct oil.
<b>Transmission Oil Pressure Indicator Reads HOT</b>	Gauge	See your authorized dealer.
	Sender	See your authorized dealer.
<b>Horn Does Not Sound</b>	Wiring harness	See your authorized dealer.
	Horn	See your authorized dealer.
	Horn fuse	See your authorized dealer.
	Horn relay	See your authorized dealer.
	Horn switch	See your authorized dealer.
<b>Reverse Alarm Does Not Sound</b>	Wiring harness	See your authorized dealer.
	Reverse alarm	See your authorized dealer.
<b>Front or Rear Wiper Does Not Work</b>	Wiper fuse	Replace fuse.
	Wiper switch problem	See your authorized dealer.
	Wiper motor problem	See your authorized dealer.
	Wiring harness problem	See your authorized dealer.
<b>Defrost Fan Motor Does Not Work</b>	Fuse	Replace fan fuse.
	Fan switch problem	See your authorized dealer.
	Fan motor resistor problem	See your authorized dealer.
	Wiring harness problem	See your authorized dealer.
<b>Blower Motor Does Not Work</b>	Fan motor switch problem	See your authorized dealer.
	Fan motor resistor problem	See your authorized dealer.
	Wiring harness problem	See your authorized dealer.
<b>Cab Work Lights Do Not Operate</b>	Fuse or Circuit breaker	Replace fuse or reset breaker.
	Light switch problem	See your authorized dealer.
	Cab work light relay problem	See your authorized dealer.
	Wiring harness problem	See your authorized dealer.

Continued on next page

TX,100,RR4834 -19-04DEC06-5/6

**IMPORTANT: Prevent possible engine damage.**  
 During cold temperatures, check fluidity of engine oil on dipstick. If the oil appears waxy and/or jelly-like rather than liquid, **DO NOT attempt to start engine. Use external heat source to warm the crankcase until oil appears fluid.**

3. Check all fluid levels. If low, check for leaks and add oil as required.
4. Check belts.
5. Check condition of all hoses and connections.
6. Check battery electrolyte level. Charge and install battery.
7. For machines with **tires**, check condition of tires and tire pressure.

For machines with **tracks**, check condition of tracks and track sag.

On crawler machines with non sealed-and-lubricated track chains, apply oil to the pin-to-bushing joints. Run machine back and forth several times.

8. Park machine on a hard surface to prevent tracks from freezing to ground.
9. Fill fuel tank.
10. Pre-lubricate turbocharger bearings, if equipped:
  - a. Disconnect fuel shutoff fuse.
  - b. Crank engine for 10 seconds.
  - c. Connect fuel shutoff fuse.
11. Inspect engine compartment, and remove any foreign material that may have accumulated. Start engine and



T6181AU—UN—18OCT88

run until it reaches operating temperature. Run at 1/2 speed for five minutes. Do not run at fast or slow idle.

- If engine fails to start or runs poorly after starting, change fuel filter(s). Bleed fuel system.

12. Operate all controls, levers, seat adjustments, etc.

**⚠ CAUTION: Prevent possible injury from unexpected machine movement. Clear the area of all persons before running machine through the operation procedure.**

13. Make sure the area is clear to allow for movement. Cycle all hydraulic functions several times. Check condition of all hoses and connections.
14. Park the machine with cylinder rods retracted, if possible. Turn key switch to OFF.
15. Apply LPS 3 Rust Inhibitor to exposed cylinder rod areas.

VD76477.00016A3 -19-08JAN08-2/2

### Avoid Track Damage

**IMPORTANT: Avoid machine damage. If machine is equipped with a sealed and lubricated**

**track, avoid water being forced between the plastic pins and rubber plugs while washing machine with pressure washer.**

JH91824.00002EB -19-07OCT08-1/1

**WLT Crawler Dozer Specifications****9.0 L Tier 3 /Stage III A Engine**

Item	Measurement	Specification
John Deere PowerTech® 6090H 6-Cylinder Diesel Engine Engine	Type	Turbocharged
Fuel Consumption, Typical	Consumption	14.4—20.8 L/h 3.8—5.5 gph
Rated Power at 1800 rpm	Power	137 kW SAE net horsepower 185 hp
Piston	Displacement	9.0 L 549 in. <sup>3</sup>
Maximum Net Torque at 1000 rpm	Torque Rise	800 N·m 590 lb-ft
Batteries	Voltage	12-volt
Alternator—ROPS	Amperage	55 amp
Alternator—Cab with Air Conditioning	Amperage	80 amp
Transmission	Speed	0—10 km/h 0—6.3 mph
Hydraulic System	Pressure	25 000 kPa 3625 psi.
	Flow Rate	163 L/min @ unloaded high idle 43 gpm
Undercarriage		
Track Shoes (each side)	Quantity	45
Ground Contact Area (with 30 in. shoes)	Area	49 932 cm <sup>2</sup> 7758 sq. in.
Track	Pitch	203.2 mm 8 in.
	Gauge	2235 mm 88 in.
Ground Pressure	Pressure	39.1 kPa 5.65 psi. 0.39 bar

**8.1 L Tier 2 /Stage II Engine**

Item	Measurement	Specification
John Deere PowerTECH® 6081H 6-Cylinder Diesel Engine Engine	Type	Turbocharged

Continued on next page

CS33148,000095E -19-23DEC08-1/2

**Pushbeam Crawler Dozer Specifications****9.0 L Tier 3 /Stage III A Engine**

Item	Measurement	Specification
John Deere PowerTech® 6090H 6-Cylinder Diesel Engine Engine	Type	Turbocharged
Fuel Consumption, Typical	Consumption	14.4—20.8 L/h 3.8—5.5 gph
Rated Power at 1800 rpm	Power	137 kW SAE net horsepower 185 hp
Piston	Displacement	9.0 L 549 in. <sup>3</sup>
Maximum Net Torque at 1000 rpm	Torque Rise	800 N·m 590 lb-ft
Batteries	Voltage	12-volt
Alternator—ROPS	Amperage	55 amp
Alternator—Cab with Air Conditioning	Amperage	80 amp
Transmission	Speed	0—10 km/h 0—6.3 mph
Hydraulic System	Pressure	25 000 kPa 3625 psi.
	Flow Rate	163 L/min @ unloaded high idle 43 gpm
Undercarriage		
Track Shoes (Each Side)	Quantity	40
Ground Contact Area (with 24 in. Shoes)	Area	33 794 cm <sup>2</sup> 5232 sq. in.
Track	Pitch	203.2 mm 8 in.
	Gauge	1880 mm 74 in.
Ground Pressure	Pressure	52.4 kPa 7.61 psi. 0.52 bar

**8.1 L Tier 2 /Stage II Engine**

Item	Measurement	Specification
John Deere PowerTECH® 6081H 6-Cylinder Diesel Engine Engine	Type	Turbocharged

Continued on next page

CS33148,0000964 -19-23DEC08-1/2

**LGP Pushbeam Crawler Dozer Specifications****9.0 L Tier 3 /Stage III A Engine**

Item	Measurement	Specification
John Deere PowerTech® 6090H 6-Cylinder Diesel Engine Engine	Type	Turbocharged
Fuel Consumption, Typical	Consumption	14.4—20.8 L/h 3.8—5.5 gph
Rated Power at 1800 rpm	Power	151 kW SAE net horsepower 200 hp
Piston	Displacement	9.0 L 549 in. <sup>3</sup>
Maximum Net Torque at 1000 rpm	Torque Rise	880 N·m 650 lb-ft
Batteries	Voltage	12-volt
Alternator—ROPS	Amperage	55 amp
Alternator—Cab with Air Conditioning	Amperage	80 amp
Transmission	Speed	0—10 km/h 0—6.3 mph
Hydraulic System	Pressure	25 000 kPa 3625 psi.
	Flow Rate	163 L/min @ unloaded high idle 43 gpm
Undercarriage		
Track Shoes (each side)	Quantity	45
Ground Contact Area (with 36 in. shoes)	Area	59 787 cm <sup>2</sup> 9310 sq. in.
Track	Pitch	203.2 mm 8 in.
	Gauge	2184 mm 86 in.
Ground Pressure	Pressure	33.3 kPa 4.80 psi. 0.33 bar

**8.1 L Tier 2 /Stage II Engine**

Item	Measurement	Specification
John Deere PowerTECH® 6081H 6-Cylinder Diesel Engine Engine	Type	Turbocharged

Continued on next page

CS33148,000096A -19-23DEC08-1/2

CLICK HERE TO **DOWNLOAD** THE COMPLETE MANUAL

- Thank you very much for reading the preview of the manual.
- You can download the complete manual from: [www.heydownloads.com](http://www.heydownloads.com) by clicking the link below



- Please note: If there is no response to CLICKING the link, please download this PDF first and then click on it.

CLICK HERE TO **DOWNLOAD** THE COMPLETE MANUAL