

**60 P**  
**Compact Excavator**  
(PIN: 1FF060PA\_ \_J\_00001— )



**JOHN DEERE**



**OPERATOR'S MANUAL**  
**60 P Compact Excavator**  
OMT489509X019 ISSUE E3 (ENGLISH)

CALIFORNIA  
Proposition 65 Warning

Diesel engine exhaust and some of its constituents are known to the State of California to cause cancer, birth defects, and other reproductive harm.

If this product contains a gasoline engine:

**⚠ WARNING**

The engine exhaust from this product contains chemicals known to the State of California to cause cancer, birth defects or other reproductive harm.

The State of California requires the above two warnings.

**Worldwide Construction  
And Forestry Division**

CLICK HERE TO **DOWNLOAD** THE COMPLETE MANUAL

- Thank you very much for reading the preview of the manual.
- You can download the complete manual from: [www.heydownloads.com](http://www.heydownloads.com) by clicking the link below



- Please note: If there is no response to CLICKING the link, please download this PDF first and then click on it.

CLICK HERE TO **DOWNLOAD** THE COMPLETE MANUAL



### Work In Ventilated Area

Engine exhaust fumes can cause sickness or death. If it is necessary to run an engine in an enclosed area, remove the exhaust fumes from the area with an exhaust pipe extension.

If you do not have an exhaust pipe extension, open the doors and get outside air into the area.

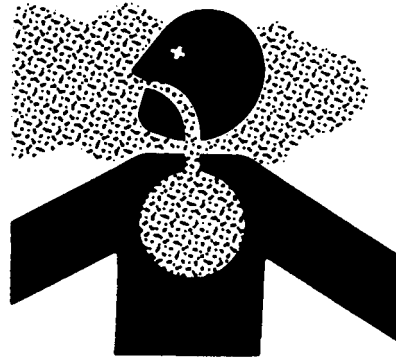

TS220 —UN—15APR13

DX,AIR -19-17FEB99-1/1

### Avoid Static Electricity Risk When Refueling

The removal of sulfur and other compounds in Ultra-Low Sulfur Diesel (ULSD) fuel decreases its conductivity and increases its ability to store a static charge.

Refineries may have treated the fuel with a static dissipating additive. However, there are many factors that can reduce the effectiveness of the additive over time.

Static charges can build up in ULSD fuel while it is flowing through fuel delivery systems. Static electricity discharge when combustible vapors are present could result in a fire or explosion.

Therefore, it is important to ensure that the entire system used to refuel your machine (fuel supply tank, transfer pump, transfer hose, nozzle, and others) is properly grounded and bonded. Consult with your fuel or fuel system supplier to ensure that the delivery system is in compliance with fueling standards for proper grounding and bonding practices.



RG22142 —UN—17MAR14

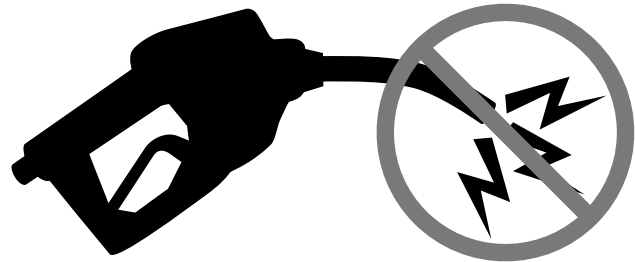

RG21992 —UN—21AUG13

DX,FUEL,STATIC,ELEC -19-12JUL13-1/1

### High Debris Applications

Many operations create flammable debris such as mulching, shredding, recycling, and agricultural applications. Operating in such environments may require frequent cleaning of the machine and attachments. Frequency of cleaning will vary depending on a number of factors, including operating conditions and weather.



Flammable Debris

T133552 —UN—15APR13

TX,HIGH,DEBRIS,APP -19-06MAR22-1/1

## Inspect and Maintain ROPS

A damaged rollover protective structure (ROPS) should be replaced, not reused.

The protection offered by ROPS could be impaired if ROPS is subjected to structural damage, is involved in an overturn incident, or is in any way altered by welding, bending, drilling, or cutting.

If ROPS was loosened or removed for any reason, inspect it carefully before operating the machine again.

To maintain the ROPS:

- Replace missing hardware using correct grade hardware.
- Check hardware torque.
- Check isolation mounts for damage, looseness, or wear; replace them if necessary.
- Check ROPS for cracks or physical damage.

TX,ROPS -19-20JAN11-1/1

## Travel Safely

When working on steep slopes, travel as straight up and down as possible to prevent roll over.

### **DO NOT PARK ON A HILLSIDE OR AN INCLINE.**

Always park the machine on level ground.

Know the location of bystanders before moving the machine.

Always keep the reverse/travel warning alarm in working condition. The alarm warns bystanders when the machine starts to move in reverse.

Use a signal person when moving the machine in congested areas. Coordinate hand signals before starting the machine.

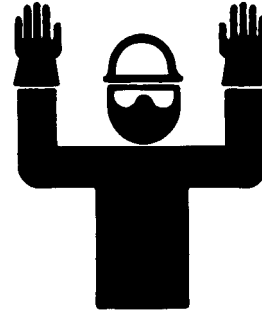

*Travel Safely*

T6964AD —UN—20DEC88

TX,TRAVEL,SAFE1 -19-08MAY20-1/1

10. **CAUTION, Avoid Burns**

To avoid burns, be careful not to contact hot surfaces.

This safety label is located at the rear of the machine to the left of the engine compartment.



CAUTION, Avoid Burns

gj9rmq2,1679665267519 -19-27MAR23-11/34

TX1127630 —19—19DEC12

11. **WARNING, Stay Clear**

Operator may swing or reverse machine

STAY CLEAR

This safety label is located at the rear of the machine below the engine compartment.



WARNING, Stay Clear

gj9rmq2,1679665267519 -19-27MAR23-12/34

TX1104370 —19—19DEC12

12. **CAUTION, Pressurized**

PRESSURIZED. DO NOT OPEN HOT.

Remove slowly.

This safety label is located inside the rear maintenance access door above the radiator cap.



CAUTION, Pressurized

Continued on next page

gj9rmq2,1679665267519 -19-27MAR23-13/34

TX1127629 —19—06DEC12

# Operation—Operator's Station

## Pedals and Levers

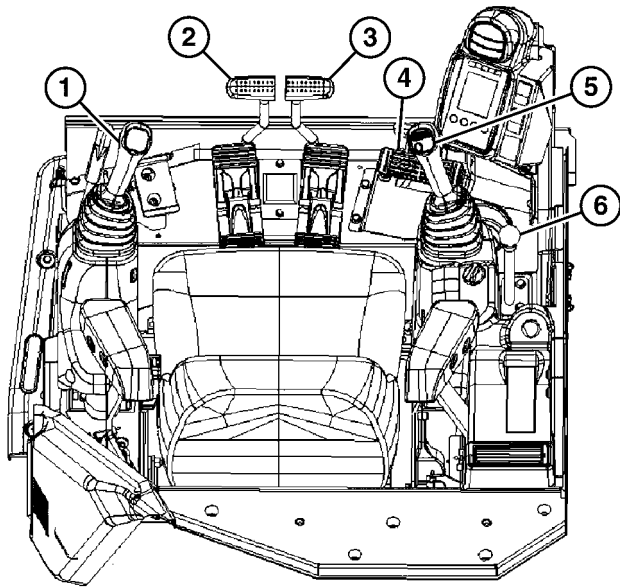

*Pedals and Levers*

TX1126062—UN—20NOV12

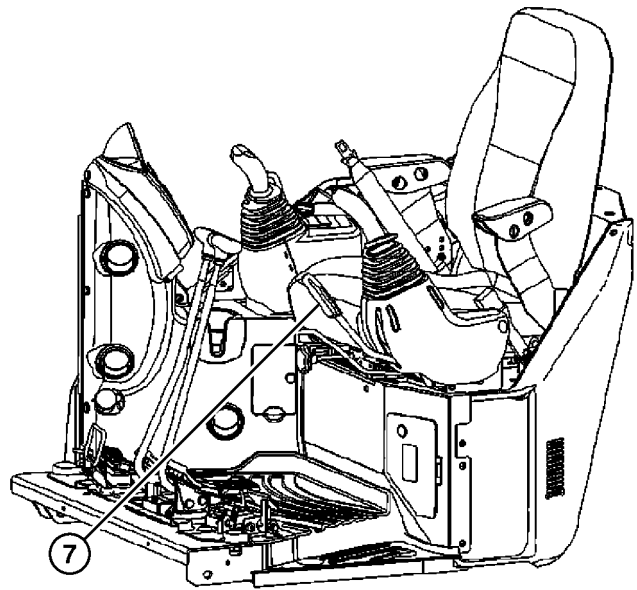

*Pilot Shutoff Lever*

TX1126389—UN—21NOV12

- 1— Left Control Lever
- 2— Left Travel Lever
- 3— Right Travel Lever
- 4— Boom Swing Pedal

- 5— Right Control Lever
- 6— Blade Control Lever
- 7— Pilot Shutoff Lever
- 8— Angle Blade Control Lever  
(if equipped)

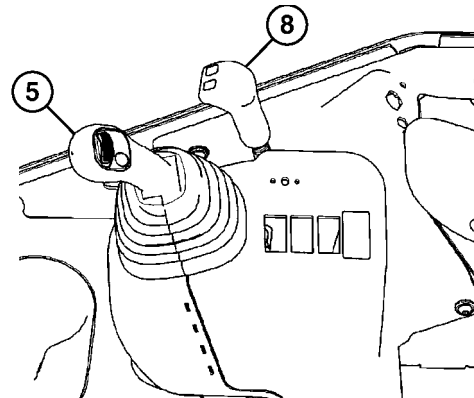

*Angle Blade Control Lever (if equipped)*

TX1126390—UN—18DEC12

KR46761,00007B4 -19-30MAR17-1/1

5. Press display button again to change display to minutes. Press tuning/time increase up button or tuning/time decrease down button to change the minutes.

6. Press display button again to exit the clock adjustment mode.

DH10862,00005DD -19-08APR21-3/3

### Cab Dome Light Switch—If Equipped

**NOTE:** The cab dome light will not turn on if the key switch is in the OFF position.

The cab dome light is located inside the cab near the left cab post.

The cab dome light switch has three positions:

- **On (1):** The cab dome light turns on and stays on until switch is moved to the off position.
- **Cab door (2):** The cab dome light turns on when the door is opened. When the cab door is closed or cab door is left in the open position for 30 seconds or longer, the cab dome light turns off automatically.
- **Off (3):** The cab dome light turns off and stays off until switch is moved to the on position or cab door position.



Cab Dome Light

1— On  
2— Cab Door

3— Off

KR46761,00007C9 -19-08MAY18-1/1

TX1235733A —UN—13MAR17

### 12 Volt Auxiliary Power Outlet

A 12-volt auxiliary power outlet (1) is provided for service and maintenance.

1— 12-Volt Auxiliary Power Outlet



12-Volt Outlet

KR46761,00006EA -19-30MAR17-1/1

TX1126778A —UN—28NOV12

## Menu

When the default screen (1) is displayed, press the menu button (2a) to display the menu screen (3).

The menu screen displays submenus which can be selected to view diagnostic information or change various operating characteristics of the machine or the monitor.

*NOTE: Translations shown on screen may be abbreviated.*

The submenus under menu that appear on monitor include:

*NOTE: The alarm list menu ONLY appears as a submenu if there is an actual alarm.*

*The alarm list menu will always be displayed first on the menu screen if there is an actual alarm.*

- **Alarm list**—provides detailed information of generated alarms.
- **Auto-shutdown**—provides the capability to turn on auto-shutdown and set a desired time for machine shutdown to take place.
- **Auto exhaust filter cleaning**—allows the operator to enable or disable the auto cleaning function for the exhaust filter.
- **Clock**—allows operator to view and adjust clock settings.
- **Trip**—allows operator to view operation hours and set trip meters.
- **Brightness adjustment**—allows operator to adjust the brightness of the monitor for better viewing.

Use up arrow button (4) and down arrow button (5) to highlight desired submenu. Press select button (6) to display chosen submenu.

Press back button (2b) to return to previous screen.

- 1— Default Screen
- 2a— Menu Button
- 2b— Back Button
- 3— Menu Screen

- 4— Up Arrow Button
- 5— Down Arrow Button
- 6— Select Button

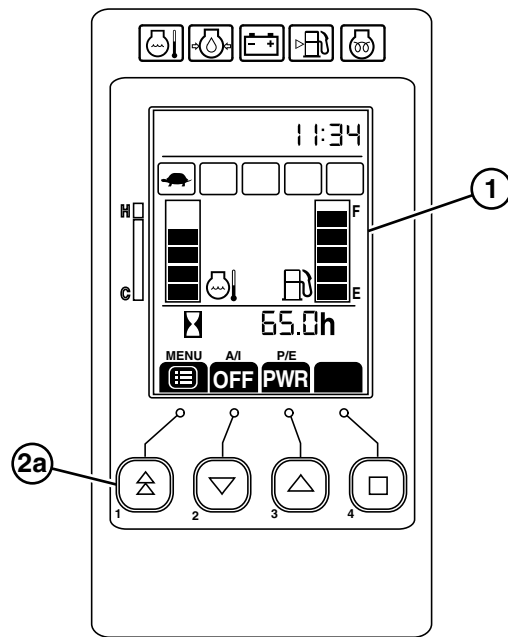

Default Screen

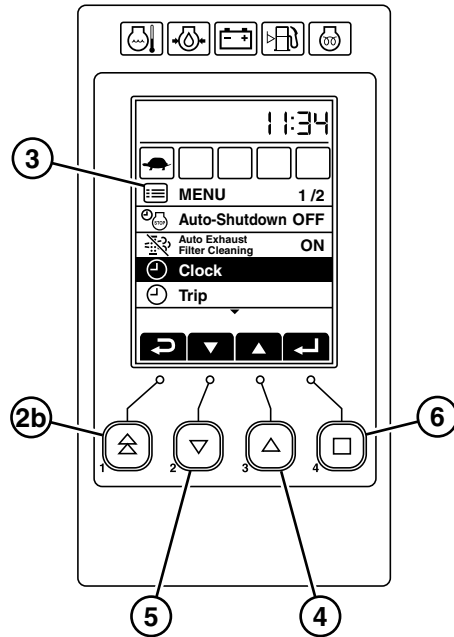

Menu Screen

KR46761,0000749 -19-15MAR17-1/1

TX1235290 —UN—16MAR17

TX1235742 —UN—14MAR17

## Engine Break-In Period

**IMPORTANT: To avoid engine damage, it is critical to observe the engine break-in period. Extra care during the first 500 hours of operation will result in more satisfactory long-term engine performance and life.**

1. Operate the machine with the engine output less than 80% of the maximum output for the first 50 hours. Avoid prolonged periods of engine maximum load operation.
2. Check engine oil level more frequently during the engine break-in period.
3. Change oil and oil filter after first 500 hours of operation (maximum). Fill crankcase with the normal

seasonal viscosity grade oil. See Diesel Engine Oil. (Section 3-1.)

4. Watch coolant temperature gauge closely. If coolant temperature rises above specified limits on the gauge, reduce load on engine. Unless temperature drops quickly, stop the engine and determine the cause before resuming operation. See Miscellaneous—Troubleshooting.
5. Watch for low oil pressure warning during operation.
6. Check belt for proper alignment and seating in pulley grooves.

KR46761,0001590 -19-12JUN17-1/1

## Starting the Engine

1. Confirm pilot shutoff lever is in the locked (UP) position to start machine.
2. Sound horn to alert persons nearby.
3. Move engine speed dial (4) to slow idle (5).

**IMPORTANT: Prevent starter damage. Never operate starter for more than 15 seconds at a time. If engine does not start, return key switch to the OFF (1) position. Wait for approximately 30 seconds, then try again. After a false start, DO NOT turn key switch until engine stops.**

4. Turn key switch to the START (3) position. Release key; key switch will return to the ON (2) position.

1— OFF  
2— ON  
3— START

4— Engine Speed Dial  
5— Slow Idle  
6— Fast Idle

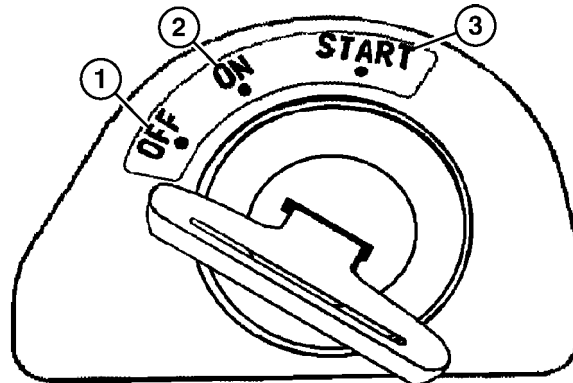

Key Switch

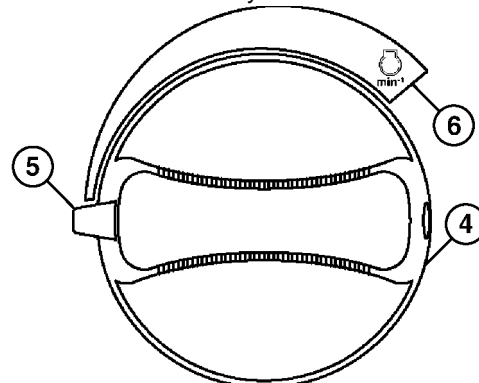

Engine Speed Dial

TX1126205—UN—20NOV12

TX1126244—UN—20NOV12

KR46761,00007AC -19-02MAR17-1/1

## Control Lever Pattern Operation

**CAUTION:** Avoid personal injury from unexpected machine movement. Never place any part of body beyond window frame to avoid serious crushing injury from boom. Boom could lower if the control lever is accidentally bumped or otherwise engaged. Immediately replace a missing or broken window.

Prevent injury from unexpected control lever function. Be aware of the control lever pattern used on the machine before operating.

The machine comes equipped from the factory with the excavator control lever pattern. A label, with both the excavator and backhoe control lever patterns, is located inside the cab.

Check the patterns on the label and then carefully operate the control levers to verify the pattern on machine.

To change the pattern from excavator to backhoe, see Control Lever Pattern Conversion in this section.

Control levers return to neutral when released. Functions will stop and remain positioned. The parking brake for swing and travel will engage.

- |                |                |
|----------------|----------------|
| 1— Arm Out     | 5— Boom Down   |
| 2— Arm In      | 6— Boom Up     |
| 3— Swing Left  | 7— Bucket Load |
| 4— Swing Right | 8— Bucket Dump |

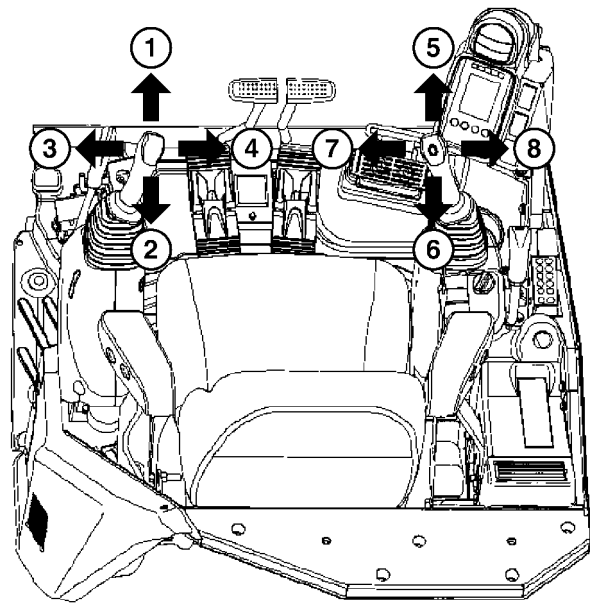

Excavator Control Lever Pattern

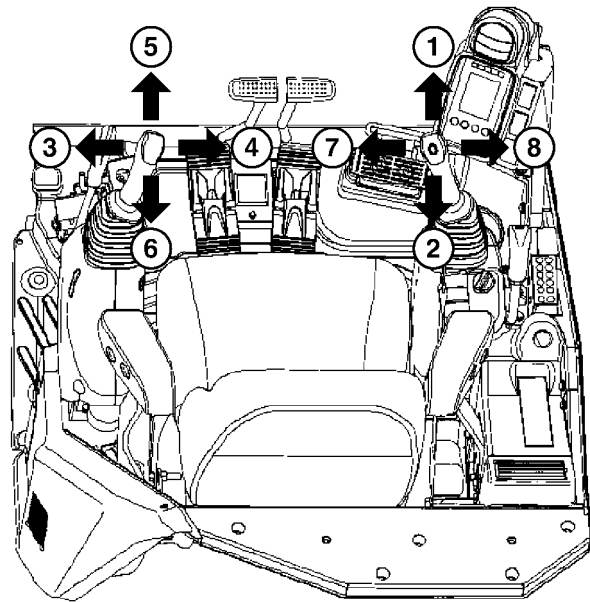

Backhoe Control Lever Pattern

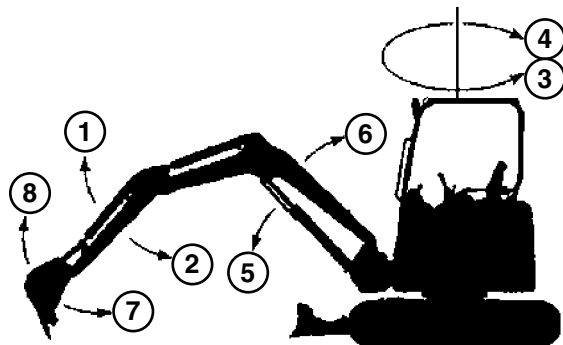

Boom, Arm, and Bucket Movement

TX1126572 —UN—27NOV12

TX1126574 —UN—27NOV12

TX1237093 —UN—06APR17

JS93577.0000043 -19-06APR17-1/1

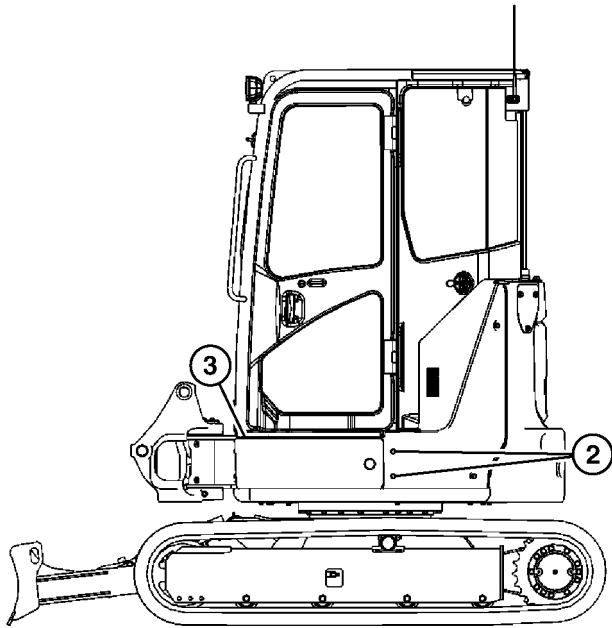

Control Valve Cover (cab machine shown)

- Remove cap screws (2) and cover (3) to access control valve.

**Lowering boom with empty bucket:**

**CAUTION:** Prevent possible injury from escaping oil under pressure. Do not loosen relief valve (4) more than 3/4 of a turn, as hydraulic oil may spray from the control valve. Prevent boom from lowering suddenly. Loosen relief valve **SLOWLY**.

- Loosen relief valve (4) slowly to lower boom.
- After the bucket is lowered to the ground, tighten relief valve to specification.

**Specification**

Relief Valve—Torque.....	60—70 N·m
	44—52 lb·ft

**Lowering boom with full bucket:**

- Make an alignment mark on relief valve and adjusting screw (5).
- Loosen lock nut (6).

**CAUTION:** Prevent possible injury from escaping oil under pressure. Loosen adjusting screw (5) **SLOWLY** as hydraulic oil may spray from the adjusting screw. Prevent boom from lowering rapidly. Loosen adjusting screw **SLOWLY**.

- Loosen adjusting screw slowly to lower boom.

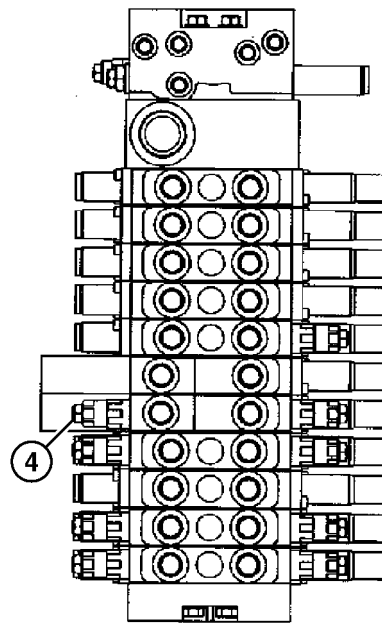

Control Valve

TX1126656 —UN—27NOV12

TX1126662 —UN—27NOV12

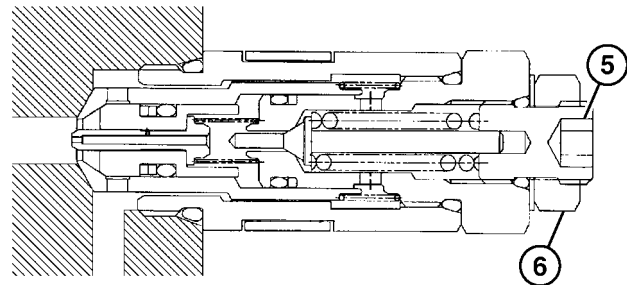

Relief Valve

TX1126664 —UN—27NOV12

- |                       |                    |
|-----------------------|--------------------|
| 2— Cap Screw (2 used) | 5— Adjusting Screw |
| 3— Cover              | 6— Lock Nut        |
| 4— Relief Valve       |                    |

- After the bucket is lowered to the ground, align marks on relief valve and adjusting screw. Tighten lock nut to specification.

**Specification**

Lock Nut—Torque.....	28—32 N·m
	21—24 lb·ft

- Install cap screws and cover. Tighten hydraulic tank cap.

KR46761,00007BF -19-07MAY18-2/2

## Biodiesel Fuel

Biodiesel fuel is comprised of monoalkyl esters of long chain fatty acids derived from vegetable oils or animal fats. Biodiesel blends are biodiesel mixed with petroleum diesel fuel on a volume basis.

Before using fuel containing biodiesel, review the Biodiesel Use Requirements and Recommendations in this Operator's Manual.

Environmental laws and regulations can encourage or prohibit the use of biofuels. Operators should consult with appropriate governmental authorities prior to using biofuels.

### John Deere Stage V Engines Operating in the European Union

Where the engine is to be operated within the Union on diesel or non-road gas-oil, a fuel with a FAME content not greater than 8% volume/volume (B8) shall be used.

### John Deere Engines with Exhaust Filter Except Stage V Engines Operating in the European Union

Biodiesel blends up to B20 can be used ONLY if the biodiesel (100% biodiesel or B100) meets ASTM D6751, EN 14214, or equivalent specification. Expect a 2% reduction in power and a 3% reduction in fuel economy when using B20.

Biodiesel concentrations above B20 can harm the engine's emission control systems and should not be used. Risks include, but are not limited to, more frequent stationary regeneration, soot accumulation, and increased intervals for ash removal.

John Deere Fuel conditioners or equivalent, which contain detergent and dispersant additives, are required when using biodiesel blends from B10 to B20, and are recommended when using lower biodiesel blends.

### John Deere Engines Without Exhaust Filter

Biodiesel blends up to B20 can be used ONLY if the biodiesel (100% biodiesel or B100) meets ASTM D6751, EN 14214, or equivalent specification. Expect a 2% reduction in power and a 3% reduction in fuel economy when using B20.

These John Deere engines can operate on biodiesel blends above B20 (up to 100% biodiesel). Operate at levels above B20 ONLY if the biodiesel is permitted by law and meets the EN 14214 specification (primarily available in Europe). Engines operating on biodiesel blends above B20 might not fully comply with or be permitted by all applicable emissions regulations. Expect up to a 12% reduction in power and an 18% reduction in fuel economy when using 100% biodiesel.

John Deere fuel conditioners or equivalent, which contain detergent and dispersant additives, are required when using biodiesel blends from B10 to B100, and are recommended when using lower biodiesel blends.

## Biodiesel Use Requirements and Recommendations

The petroleum diesel portion of all biodiesel blends must meet the requirements of ASTM D975 (US) or EN 590 (EU) commercial standard.

Biodiesel users in the U.S. are strongly encouraged to purchase biodiesel blends from a BQ-9000 Certified Marketer and sourced from a BQ-9000 Accredited Producer (as certified by the National Biodiesel Board). Certified Marketers and Accredited Producers can be found at the following website: <http://www.bq9000.org>.

Biodiesel contains residual ash. Ash levels exceeding the maximums allowed in either ASTM D6751 or EN14214 can result in more rapid ash loading and require more frequent cleaning of the Exhaust Filter (if present).

The fuel filter can require more frequent replacement when using biodiesel fuel, particularly if switching from diesel. Check engine oil level daily prior to starting engine. A rising oil level can indicate fuel dilution of the engine oil. Biodiesel blends up to B20 must be used within 90 days of the date of biodiesel manufacture. Biodiesel blends above B20 must be used within 45 days from the date of biodiesel manufacture.

When using biodiesel blends up to B20, the following must be considered:

- Cold-weather flow degradation
- Stability and storage issues (moisture absorption, microbial growth)
- Possible filter restriction and plugging (usually a problem when first switching to biodiesel on used engines)
- Possible fuel leakage through seals and hoses (primarily an issue with older engines)
- Possible reduction of service life of engine components

Request a certificate of analysis from your fuel distributor to ensure that the fuel is compliant with the specifications provided in this Operator's Manual.

Consult your John Deere dealer for John Deere fuel products to improve storage and performance with biodiesel fuels.

The following must also be considered if using biodiesel blends above B20:

- Possible coking or blocked injector nozzles, resulting in power loss and engine misfire if John Deere fuel additives and conditioners or equivalent containing detergent/dispersants are not used
- Possible crankcase oil dilution (requiring more frequent oil changes)
- Possible lacquering or seizure of internal components
- Possible formation of sludge and sediments
- Possible thermal oxidation of fuel at elevated temperatures

## Testing Coolant Freeze Point

The use of a handheld coolant refractometer is the quickest, easiest, and most accurate method to determine coolant freeze point. This method is more accurate than a test strip or a float-type hydrometer which can produce poor results.

A coolant refractometer is available through your John Deere dealer under the SERVICEGARD™ tool program. Part number 75240 provides an economical solution to accurate freeze point determination in the field.

To use this tool:

1. Allow cooling system to cool to ambient temperatures.
2. Open radiator cap to expose coolant.
3. With the included dropper, collect a small coolant sample.
4. Open the lid of the refractometer, place one drop of coolant on the window and close the lid.
5. Look through the eyepiece and focus as necessary.
6. Record the listed freeze point for the type of coolant (ethylene glycol coolant or propylene glycol) being tested.



SERVICEGARD™ Part Number 75240

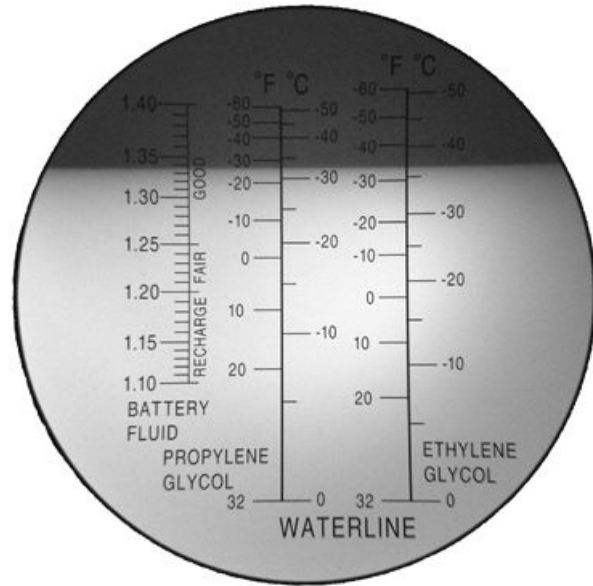

Image with a Drop of 50/50 Coolant Placed on the Refractometer Window

SERVICEGARD is a trademark of Deere & Company

DX,COOL,TEST -19-13JUN13-1/1

TS1732—UN—04SEP13

TS1733—UN—04SEP13

## Disposing of Coolant

Improperly disposing of engine coolant can threaten the environment and ecology.

Use leakproof containers when draining fluids. Do not use food or beverage containers that may mislead someone into drinking from them.

Do not pour waste onto the ground, down a drain, or into any water source.

Inquire on the proper way to recycle or dispose of waste from a local environmental or recycling center, or from an authorized John Deere dealer.

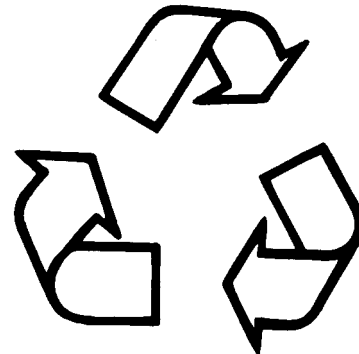

Recycle Waste

TX,COOL,DISP -19-26OCT20-1/1

TS1133—UN—15APR13

## Check Windshield Washer Fluid Level—If Equipped

*NOTE: All-season windshield washer fluid is recommended during the winter season.*

Check fluid level in windshield washer fluid reservoir (1) and refill as required.

1— Windshield Washer Fluid Reservoir

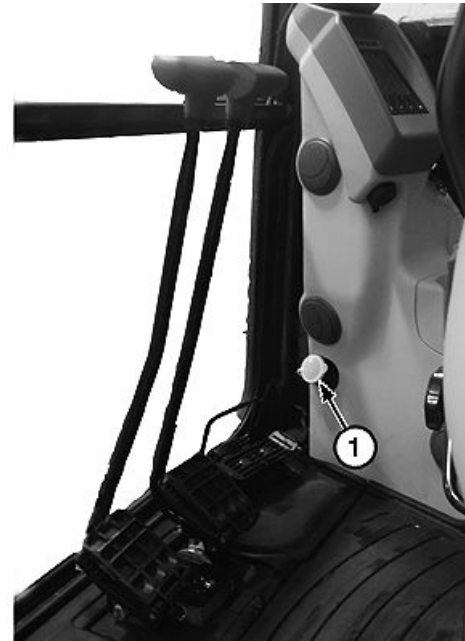

Washer Fluid Reservoir

TX1125945A—UN—16NOV12

KR46761,00006C5 -19-30MAR17-1/1

## Hydraulic Breaker and Crusher Attachments

**IMPORTANT:** Avoid mixing different brands or types of oils. Oil manufacturers engineer their oils to meet certain specifications and performance requirements. Mixing different oil types can degrade lubricant and machine performance.

This excavator is factory filled with 46HN extended life zinc-free hydraulic oil. Avoid servicing this excavator with products that do not meet this specification. If oils have been

mixed or if alternate service oils are desired, the complete hydraulic system needs to be totally flushed by an authorized dealer.

Hydraulic breaker or crusher operation subjects the machine's hydraulic system to possible contamination and accelerated deterioration. The hydraulic return filter and hydraulic oil must be replaced more often to prevent damage to hydraulic pumps and other hydraulic components. Use of different attachments may shorten oil change interval. Use this table for reference.

Bucket, Breaker, and Crusher Attachments			
Attachment	Percentage of Operating Time	Hydraulic Return Filter Change Interval	Hydraulic Oil Change Interval
Bucket	100%	500 hours	2000 hours
Breaker or Crusher	100%	250 hours	1000 hours

KR46761,00006C6 -19-30MAR17-1/1

CLICK HERE TO **DOWNLOAD** THE COMPLETE MANUAL

- Thank you very much for reading the preview of the manual.
- You can download the complete manual from: [www.heydownloads.com](http://www.heydownloads.com) by clicking the link below



- Please note: If there is no response to CLICKING the link, please download this PDF first and then click on it.

CLICK HERE TO **DOWNLOAD** THE COMPLETE MANUAL

### Check Track Sag—Steel Track—If Equipped

1. Rotate upperstructure 90° and lower bucket to raise track off ground.
2. Keep the angle (1) between boom and arm 90—110° and position the round side of the bucket on the ground.

**⚠ CAUTION: Prevent possible injury from unexpected machine movement. Place blocks under machine frame to support machine while measuring track sag.**

3. Place blocks under machine frame to support machine.
4. Rotate track forward two full rotations and then in reverse two full rotations.
5. Stop engine.
6. Measure track sag distance (2) at middle track roller from bottom of track frame to top surface of track shoe.

**Specification**

Track—Sag.....140—160 mm  
5.5—6.3 in

7. If not to specification, adjust track sag. See Adjust Track Sag in this section.
8. Repeat check on other side of machine.

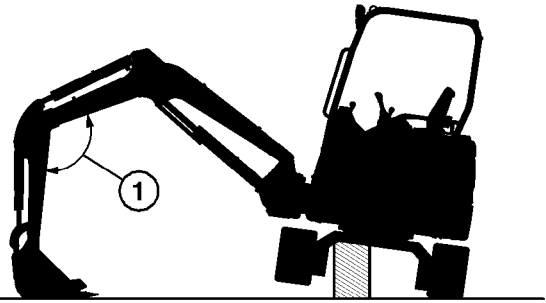

T204987

Machine Position (canopy machine shown)

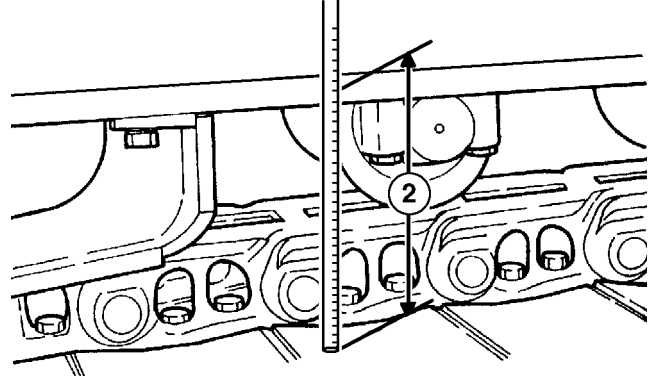

Track Sag Measurement

1— Angle

2— Track Sag Distance

JS93577,000005A -19-15MAR17-1/1

T204987—UN—30NOV04

TX1103806—UN—18DEC11

### Lubricate Front End Pin Joints

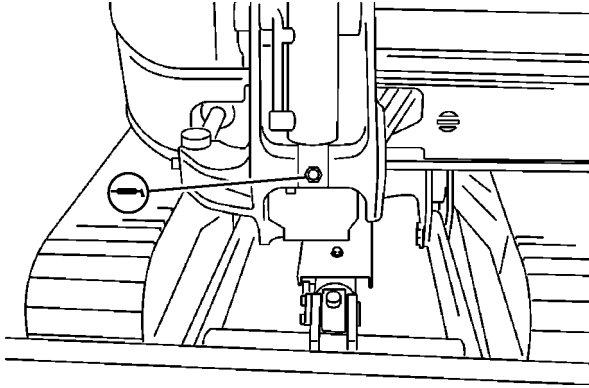

Boom Cylinder Bottom Side

TX1127732—UN—07DEC12

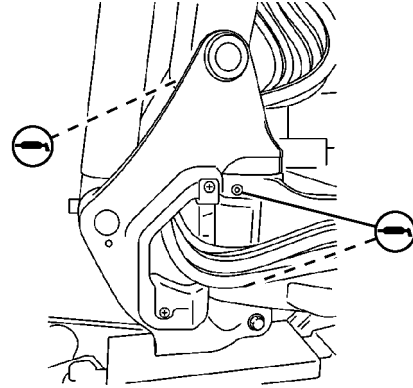

Boom Foot and Swing Post

TX1198319—UN—23JUL15

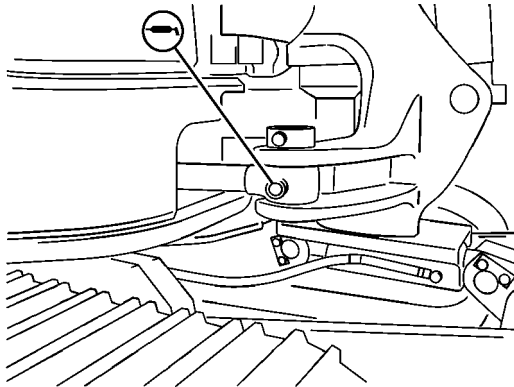

Boom Swing Cylinder

TX1127734—UN—07DEC12

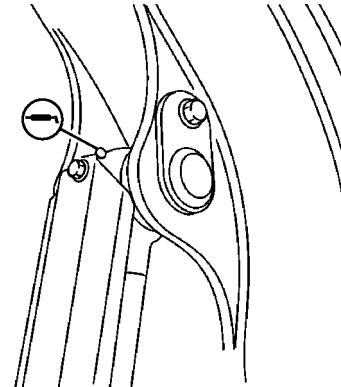

Boom Cylinder Rod Side

TX1127735—UN—07DEC12

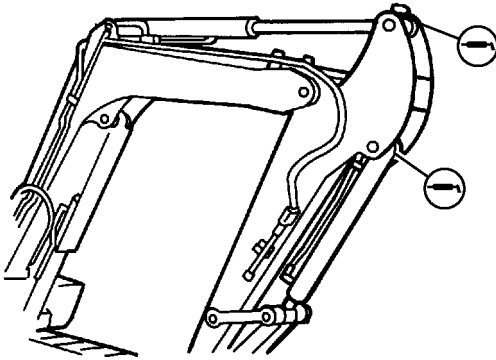

Arm Cylinder Rod Side, Bucket Cylinder Bottom Side

TX1127737—UN—07DEC12

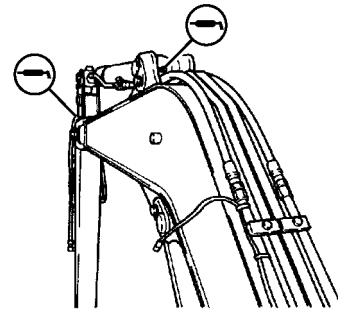

Boom and Arm Joint Pin, Arm Cylinder Bottom Side

TX1127738—UN—07DEC12

Lubricate front end pin joints (10 points) until grease escapes from joints. See Grease. (Section 3-1.)

Lubricate every 10 hours when working in mud and water.

Lubricate every 10 hours for first 50 hours of operation.

Lubricate every 50 hours when using hydraulic breaker.

Lubricate every 100 hours for first 500 hours of operation and then at 500 hour intervals thereafter.

KR46761,0000760 -19-22JUL15-1/1

### Lubricate Blade Pins

Lubricate blade pins (4 points) until grease escapes from joint. See Grease. (Section 3-1.)

Lubricate angle blade (if equipped) (3 points) until grease escapes from fitting. See Grease. (Section 3-1.)

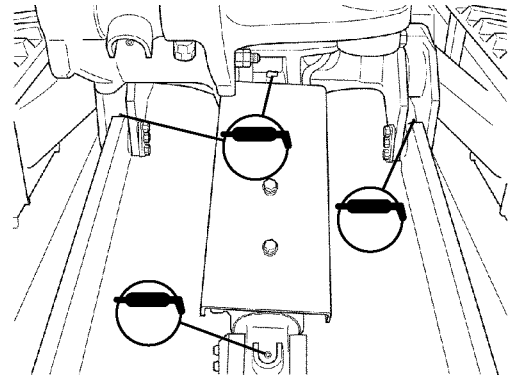

T205163

Blade Pins

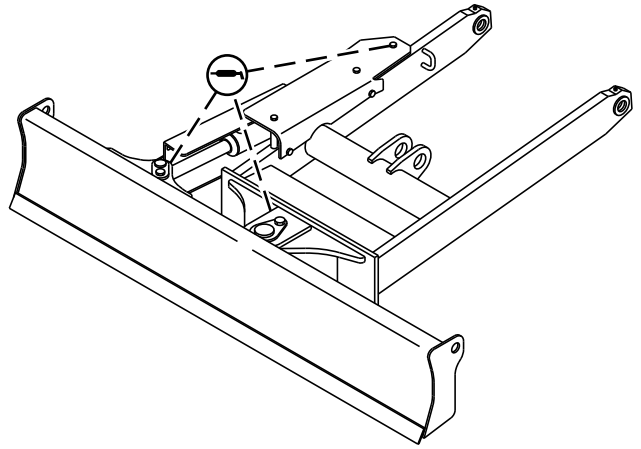

Angle Blade (if equipped)

KR46761,00006DF -19-15MAR17-1/1

## Drain Cooling System



Pressurized Fluids

1. Park machine on a level surface.
2. Open rear maintenance access door. Check coolant hoses for cracks and leaks. Replace if necessary.
3. Tighten clamps.
4. Check radiator and oil cooler for dirt, grease, leaks, and loose or broken mountings. Clean radiator and oil cooler fins. See Clean Radiator Core and Oil Cooler. (Section 3-3.)

**⚠ CAUTION: Prevent possible injury from hot, spraying fluids. Shut off engine. Remove radiator cap (1) only when cool enough to touch with bare hands. Slowly loosen cap to first stop to relieve pressure before removing completely.**

5. Slowly turn radiator cap (1) to release pressure. Remove cap.
6. Remove access panel (2) to access radiator drain valve (3).
7. Open drain valve. Allow coolant to drain into a container. Dispose of waste coolant properly.
8. Close radiator drain valve and install access panel.
9. Install radiator cap. Close rear maintenance access door.

1— Radiator Cap  
2— Access Panel

3— Radiator Drain Valve



TS281 —UN—15APR13

Radiator Cap (cab machine shown)

TX1127028A —UN—30NOV12



Access Panel

TX1340914A —UN—27MAR23

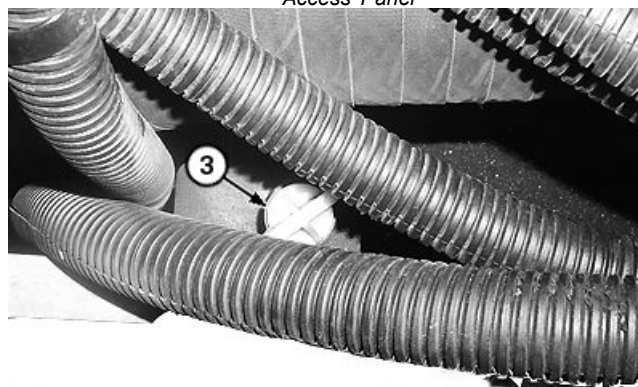

Radiator Drain Valve

TX1127138A —UN—30NOV12

gj9rmq2,1679950287989 -19-27MAR23-1/1

## Using Booster Batteries—12-Volt System

Before boost starting, machine must be properly shut down to prevent unexpected machine movement when engine starts.

**CAUTION:** Prevent possible injury from exploding battery. An explosive gas is produced while batteries are in use or being charged. Keep flames or sparks away from the battery area. Make sure the batteries are charged in a well-ventilated area.

**IMPORTANT:** The machine electrical system is a 12-volt negative (-) ground. Use only 12-volt booster batteries.

1. Connect one end of the positive cable to the positive terminal of the machine batteries and the other end to the positive terminal of the booster batteries.
2. Connect one end of the negative cable to the negative terminal of the booster batteries. Connect other end of the negative cable to the machine as far away from the machine batteries as possible.
3. Start engine.
4. Immediately after starting engine disconnect end of the negative cable from the machine. Then disconnect the other end of the negative cable from the negative terminal of the booster batteries.
5. Disconnect positive cable from booster batteries and machine batteries.



Using Booster Batteries

TS204—UN—15APR13

OUT4001,0000E1 -19-21JUL17-1/1

## Replacing Battery

Open rear maintenance access door to access the battery (1).

This machine has one 12-volt battery with negative (-) ground.

Only use batteries that meet the following specification:

### Specification

Battery—Cold Cranking  
Amps (CCA) at -18°C  
(0°F).....680 CCA

If battery malfunctions, replace battery with one of the same type. For example, replace a malfunctioned maintenance-free battery with a new maintenance-free battery. Different types of batteries may have different rates of charge. This difference could overload the battery and cause it to malfunction.

1— Battery

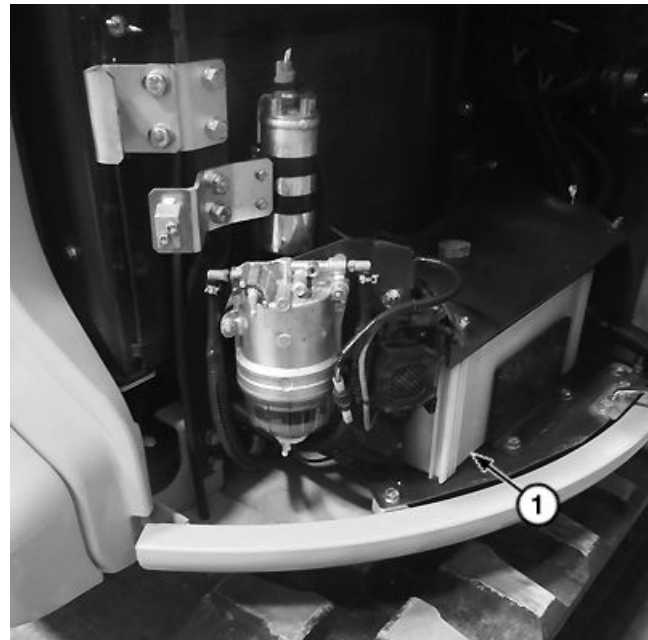

Battery Location (cab machine shown)

TX1127093A—UN—30NOV12

KR46761,0000784 -19-16MAR17-1/1

## Rubber Track Care

**CAUTION:** Prevent possible injury from unexpected machine movement. A machine with rubber track is less stable than a machine with steel shoes, as the edge of the rubber track may bend when bucket is loaded, especially when digging over the side.

When machine is driven:

- Do not operate on sharp, rocky, uneven surfaces.

**NOTE:** The rubber track has a thin rubber film on its inner surface when it is new. It is normal for the film to come off when track rubs against rollers.

- Keep the rubber track free of oil, gasoline, etc. Avoid traveling on oil to reduce the chance of slipping.
- If machine is parked or stored for more than 90 days, park in an area out of direct sunlight.
- When transporting a machine with rubber tracks, always fasten the right and left track frames securely to the trailer. Do not allow tie down chains to come into direct contact with rubber track pads.

TX,55,DH5376 -19-30MAR17-1/1

## Removing and Installing Rubber Track

### Removing Rubber Track

1. Rotate upperstructure 90° and lower bucket to raise track off ground.
2. Keep the angle between boom and arm 90—100° and position round side of the bucket on the ground.

**CAUTION:** Prevent possible injury from unexpected machine movement. Place blocks under machine frame to support machine while removing and installing track.

3. Place blocks under machine frame to support machine.

**CAUTION:** Prevent possible injury from high-pressure grease. DO NOT remove grease fitting (1) from valve (2).

4. To loosen track, slowly turn valve (2) counterclockwise. Grease will escape through the bleed hole (3).

**CAUTION:** Prevent potential injury from front idler. Do not stand in front of idler during removal of track. Front idler may come off unexpectedly.

5. Insert two or three steel pipes (4) into gaps among lower rollers, track frame, and rubber track. Rotate track slowly in reverse to lift track off idler. Pry track off idler.
6. Install the rubber track on the sprocket first. Position the other end of the rubber track on the front idler.
7. While rotating the sprocket in reverse, push on the rubber track to force it on the idler.

1— Grease Fitting  
2— Valve

3— Bleed Hole  
4— Steel Pipe (2 or 3 used)

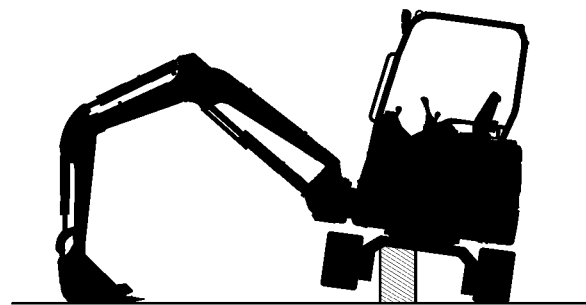

Machine Position

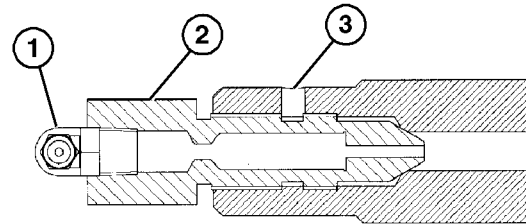

T204989

Track Adjuster

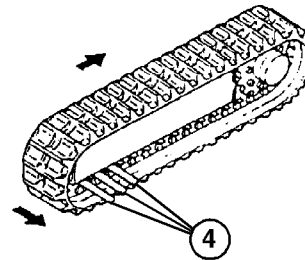

T204991

Track Direction

Continued on next page

JS93577,000005C -19-18DEC14-1/2

TX112772 —UN—07DEC12

T204989 —UN—30NOV04

T204991 —UN—30NOV04

Light Circuit Checks



TX1126274A —UN—29NOV12

Right Switch Panel

- 1— Work Light Switch
- 2— Windshield Wiper and Washer Switch
- 3— Travel Mode Switch
- 4— Engine Speed Dial

Press work light switch (1) to the ON position.

*LOOK: Is work light indicator illuminated on monitor panel and are machine work lights on?*

*LOOK: Does switch panel illuminate?*

*LOOK: Do machine work lights stay on and switch panel stay illuminated?*

**YES:** Go to next check.

**NO:** Check work light relay 25 A fuse (F3) (marked LIGHT). See Replacing Fuses. (Section 4-1.)

IF OK: See an authorized John Deere dealer.

Continued on next page

TD48962.0000090 -19-08MAY18-13/50

Turn engine speed dial to slow idle position.

*LISTEN: Does engine speed decrease?*

**NO:** Check monitor and radio 5 A fuse (F2) (marked MONITOR B, RADIO). See Replacing Fuses. (Section 4-1.)

**IF OK:** See an authorized John Deere dealer.

Continued on next page

TD48962.0000090 -19-08MAY18-24/50

 **CAUTION: Avoid possible injury. Make sure that area is clear and large enough to swing extended arm and bucket. Machine must be on level ground.**

Position upperstructure with boom to the front.

Move arm to the extended position, bucket to the retracted position, and bucket-to-arm pivot pin to the same level as boom-to-frame pivot pin.

Turn engine speed dial (1) to fast idle position.

Press power mode button (7) until PWR (power) mode is displayed on monitor.

Fully actuate swing function. Swing clockwise 90 degrees and then release lever.

*LOOK: Does upperstructure stop within 45 degrees (1/8 turn) or less after releasing lever?*

Position upperstructure with boom to the front.

Fully actuate swing function. Swing counterclockwise 90 degrees and then release lever.

*LOOK: Does upperstructure stop within 45 degrees (1/8 turn) or less after releasing lever?*

**YES:** Go to next check.

**NO:** See an authorized John Deere dealer.

Continued on next page

TD48962.0000090 -19-08MAY18-35/50

Angle Blade Check (if equipped)

**⚠ CAUTION:** Prevent possible injury from unexpected machine movement. Clear all persons from the area before operating machine.

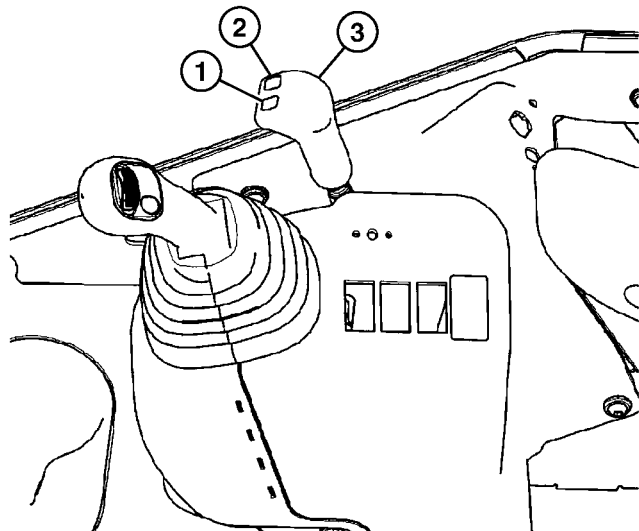

TX1127527 —UN—06DEC12

Angle Blade Control

- 1— Angle Blade Switch (left)
- 2— Angle Blade Switch (right)
- 3— Blade Control Lever

Press angle blade switch (left) (1).

*LOOK:* Does angle blade move to right position?

Press angle blade switch (right) (2).

*LOOK:* Does angle blade move to left position?

**YES:** Go to next check.

**NO:** See an authorized John Deere dealer.

Continued on next page

TD48962.0000090 -19-08MAY18-45/50

Symptom	Problem	Solution
<b>Excessive Oil Consumption</b>	Incorrect oil	Drain crankcase and refill with correct oil.
	Oil leaks	Locate source of leak and repair as required.
	Poor fuel quality	Drain fuel and replace with quality fuel of the proper grade.
	Air filter restricted or dirty	Replace filter element.
	Worn engine	See an authorized John Deere dealer.
<b>Engine Idles Poorly</b>	Poor fuel quality	Drain fuel and replace with quality fuel of the proper grade.
	Air in fuel system	Bleed air. See Bleed Fuel System. (Section 4-1.)
	Air filter restricted or dirty	Replace filter element.
	Fuel filters restricted	Replace filters. Bleed air.
	Fuel filter not installed correctly	Install new filter and O-ring. Ensure proper O-ring seal. Bleed air.
	Engine speed control system	See an authorized John Deere dealer.
	Exhaust filter restricted	See an authorized John Deere dealer.
	Worn engine	See an authorized John Deere dealer.
	<b>Auto-Idle Does Not Work</b>	Auto-idle is off
Idle is not above 1300 rpm		Turn engine speed dial clockwise to increase engine speed.
Hydraulic functions operating		Release hydraulic functions for 10 seconds.
<b>Engine Not Developing Full Power</b>	Air filter restricted or dirty	Replace filter element.
	Fuel filters restricted	Replace filters. Bleed air.
	Fuel filter not installed correctly	Install new filter and O-ring. Ensure proper O-ring seal. Bleed air.

Continued on next page

KR46761,00007F6 -19-28MAR17-3/5

# Miscellaneous—Serial Numbers

## Record Product Identification Number (PIN)

Purchase Date:

Product Identification Number (PIN):

Record all 17 characters of the product identification number (PIN).

The PIN plate (1) is located on the front right corner of the operator's station frame.

1— PIN Plate

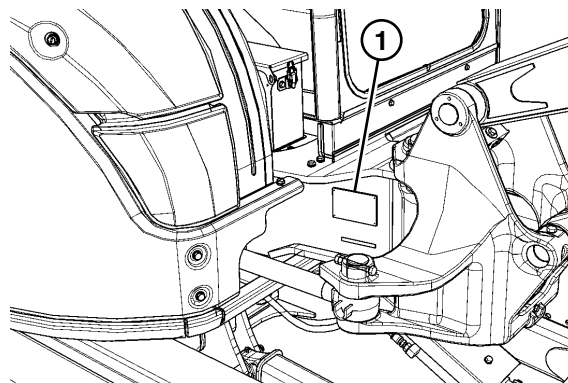

PIN Plate Location

JS93577,0000035 -19-10MAR17-1/1

TX1235693 —UN—10MAR17

## Record Engine Serial Number

Engine Serial Number:

The engine serial number plate (1) is located near the exhaust filter.

1— Engine Serial Number Plate

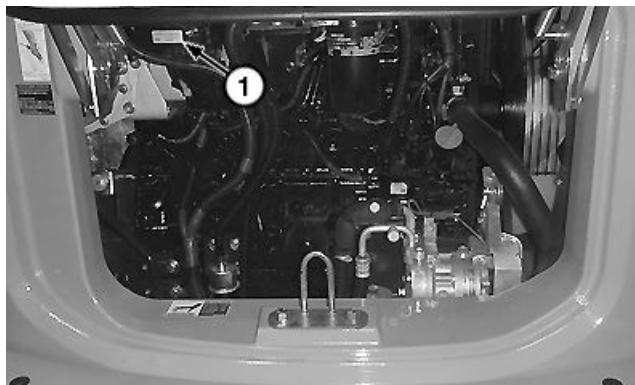

Engine Serial Number Plate

KR46761,00014F6 -19-27MAR17-1/1

TX1236063A —UN—17MAR17

## Keep Proof of Ownership

1. Maintain in a secure location an up-to-date inventory of all product and component serial numbers.
2. Regularly verify that identification plates have not been removed. Report any evidence of tampering to law enforcement agencies and order duplicate plates.
3. Other steps you can take:
  - Mark your machine with your own numbering system
  - Take color photographs from several angles of each machine



DX,SECURE1 -19-18NOV03-1/1

TS1680 —UN—09DEC03

### Lift Capacity—Cab; Long Arm; Extra Counterweight; Rubber Track; Blade on Ground

Ratings are measured with machine situated on a firm, level, and uniform supporting surface.

marked with an asterisk (\*) are hydraulically limited capacities. Remaining figures are stability-limited capacities.

Figures do not exceed 87 percent of hydraulic capacity or 75 percent of weight needed to tip machine. Figures

*NOTE: Lift capacities are listed in kg (lb).*

<b>Arm: 1.85 m (6 ft 1 in)</b>		<b>Bucket: None, Measured From Arm Pin</b>		
<b>LIFTING OVER FRONT</b>				
<b>Load Point Height</b>	<b>Horizontal Distance From Center Line of Rotation</b>			
<b>m (ft)</b>	<b>3.0 m (9 ft 10 in)</b>	<b>4.0 m (13 ft 2 in)</b>	<b>5.0 m (16 ft 5 in)</b>	<b>Maximum Reach</b>
<b>3.0 m (9 ft 10 in)</b>		1420* (3130*)	1450* (3200*)	1300* (2870*)
<b>2.0 m (6 ft 7 in)</b>	2310* (5090*)	1780* (3920*)	1570* (3460*)	1320* (2910*)
<b>1.0 m (3 ft 3 in)</b>	3350* (7390*)	2200* (4850*)	1750* (3860*)	1410* (3110*)
<b>Ground Line</b>	3810* (8400*)	2480* (5470*)	1870* (4120*)	1590* (3510*)
<b>-1.0 m (-3 ft 3 in)</b>	3750* (8270*)	2510* (5530*)	1810* (3990*)	1750* (3860*)
<b>LIFTING OVER SIDE</b>				
<b>Load Point Height</b>	<b>Horizontal Distance From Center Line of Rotation</b>			
<b>m (ft)</b>	<b>3.0 m (9 ft 10 in)</b>	<b>4.0 m (13 ft 2 in)</b>	<b>5.0 m (16 ft 5 in)</b>	<b>Maximum Reach</b>
<b>3.0 m (9 ft 10 in)</b>		1300 (2870)	910 (2010)	820 (1810)
<b>2.0 m (6 ft 7 in)</b>	1910 (4210)	1240 (2730)	890 (1960)	740 (1630)
<b>1.0 m (3 ft 3 in)</b>	1750 (3860)	1170 (2580)	860 (1900)	720 (1590)
<b>Ground Line</b>	1680 (3700)	1130 (2490)	830 (1830)	740 (1630)
<b>-1.0 m (-3 ft 3 in)</b>	1660 (3660)	1110 (2450)	830 (1830)	810 (1790)

\* Hydraulically Limited Capacities

JS93577,0000025 -19-26APR18-1/1

### Lift Capacity—Canopy; Standard Arm; Extra Counterweight; Rubber Track; Blade on Ground

Ratings are measured with machine situated on a firm, level, and uniform supporting surface.

marked with an asterisk (\*) are hydraulically limited capacities. Remaining figures are stability-limited capacities.

Figures do not exceed 87 percent of hydraulic capacity or 75 percent of weight needed to tip machine. Figures

NOTE: Lift capacities are listed in kg (lb).

Arm: 1.50 m (4 ft 11 in)		Bucket: None, Measured From Arm Pin		
<b>LIFTING OVER FRONT</b>				
<b>Load Point Height</b>	<b>Horizontal Distance From Center Line of Rotation</b>			
<b>m (ft)</b>	<b>3.0 m (9 ft 10 in)</b>	<b>4.0 m (13 ft 2 in)</b>	<b>5.0 m (16 ft 5 in)</b>	<b>Maximum Reach</b>
<b>3.0 m (9 ft 10 in)</b>	1770* (3900*)	1640* (3620*)		1640* (3620*)
<b>2.0 m (6 ft 7 in)</b>	2740* (6040*)	1980* (4370*)	1710* (3770*)	1670* (3680*)
<b>1.0 m (3 ft 3 in)</b>	3650* (8050*)	2350* (5180*)	1840* (4060*)	1740* (3840*)
<b>Ground Line</b>	3880* (8550*)	2550* (5620*)	1900* (4190*)	1820* (4010*)
<b>-1.0 m (-3 ft 3 in)</b>	3640* (8020*)	2470* (5450*)		1910* (4210*)
<b>LIFTING OVER SIDE</b>				
<b>Load Point Height</b>	<b>Horizontal Distance From Center Line of Rotation</b>			
<b>m (ft)</b>	<b>3.0 m (9 ft 10 in)</b>	<b>4.0 m (13 ft 2 in)</b>	<b>5.0 m (16 ft 5 in)</b>	<b>Maximum Reach</b>
<b>3.0 m (9 ft 10 in)</b>	1770* (3900*)	1240 (2730)		880 (1940)
<b>2.0 m (6 ft 7 in)</b>	1800 (3970)	1190 (2620)	850 (1870)	790 (1740)
<b>1.0 m (3 ft 3 in)</b>	1670 (3680)	1130 (2490)	830 (1830)	760 (1680)
<b>Ground Line</b>	1620 (3570)	1090 (2400)	810 (1790)	780 (1720)
<b>-1.0 m (-3 ft 3 in)</b>	1620 (3570)	1080 (2380)		880 (1940)

\* Hydraulically Limited Capacities

KR46761,000150C -19-26APR18-1/1

CLICK HERE TO **DOWNLOAD** THE COMPLETE MANUAL

- Thank you very much for reading the preview of the manual.
- You can download the complete manual from: [www.heydownloads.com](http://www.heydownloads.com) by clicking the link below



- Please note: If there is no response to CLICKING the link, please download this PDF first and then click on it.

CLICK HERE TO **DOWNLOAD** THE COMPLETE MANUAL