

2954D Log Loader



JOHN DEERE

OPERATOR'S MANUAL

2954D Log Loader

OMT231395 ISSUE L3 (ENGLISH)



CALIFORNIA

Proposition 65 Warning

Diesel engine exhaust and some of its constituents are known to the State of California to cause cancer, birth defects, and other reproductive harm.

If this product contains a gasoline engine:

WARNING

The engine exhaust from this product contains chemicals known to the State of California to cause cancer, birth defects or other reproductive harm.

The State of California requires the above two warnings.

**Worldwide Construction,
And Forestry Division**

PRINTED IN U.S.A.

CLICK HERE TO **DOWNLOAD** THE COMPLETE MANUAL

- Thank you very much for reading the preview of the manual.
- You can download the complete manual from: www.heydownloads.com by clicking the link below



- Please note: If there is no response to CLICKING the link, please download this PDF first and then click on it.

CLICK HERE TO **DOWNLOAD** THE COMPLETE MANUAL

**Required Emission-Related Information
Service Provider**

A repair shop or person of the owner's choosing may maintain, replace, or repair emission control devices and systems with original or equivalent replacement parts. However, warranty, recall, and all other services paid for by John Deere must be performed at an authorized John Deere service center.

DX,EMISSIONS,REQINFO-19-08DEC23-1/1

Technical Information Feedback Form

We need your help to continually improve our technical publications. Please copy this page and FAX or mail your comments, ideas and improvements.

SEND TO: John Deere Dubuque Works
18600 South John Deere Road
Attn: Publications, Dept. 324
Dubuque, IA 52004-0538
USA

FAX NUMBER: 1-563-589-5800 (USA)

Publication Number: _____

Page Number: _____

Ideas, Comments: _____

Name: _____

Phone: _____

Email Address: _____

THANK YOU!

TX,TM,FAX-19-03JUL01-1/1

Work In Ventilated Area

Engine exhaust fumes can cause sickness or death. If it is necessary to run an engine in an enclosed area, remove the exhaust fumes from the area with an exhaust pipe extension.

If you do not have an exhaust pipe extension, open the doors and get outside air into the area.



TS220—UN—15APR13

DX,AIR-19-17FEB99-1/1

Prevent Fires

Handle Fuel Safely: Store flammable fluids away from fire hazards. Never refuel machine while smoking or when near sparks or flame.

Clean Machine Regularly: Keep trash, debris, grease and oil from accumulating in engine compartment, around fuel lines, hydraulic lines, exhaust components, and electrical wiring. Never store oily rags or flammable materials inside a machine compartment.

Maintain Hoses and Wiring: Replace hydraulic hoses immediately if they begin to leak, and clean up any oil spills. Examine electrical wiring and connectors frequently for damage.

Keep A Fire Extinguisher Available: Always keep a multipurpose fire extinguisher on or near the machine. Know how to use extinguisher properly.

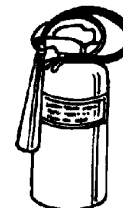

T133552—UN—15APR13

T133553—UN—07SEP00

T133554—UN—07SEP00

TX03679,00016F5-19-03NOV08-1/1

In Case of Machine Fire

- Turn the engine off.
- Turn the master disconnect switch off.
- If possible, fight the fire using the portable fire extinguisher or other fire suppression equipment.
- Ensure that the fire does not spread to the surrounding area.
- Call for help!



TS227—UN—15APR13

VD76477,00015D9-19-02JUL08-1/1

Prevent Acid Burns

Sulfuric acid in battery electrolyte is poisonous. It is strong enough to burn skin, eat holes in clothing, and cause blindness if splashed into eyes.

Avoid the hazard by:

1. Filling batteries in a well-ventilated area.
2. Wearing eye protection and rubber gloves.
3. Avoiding breathing fumes when electrolyte is added.
4. Avoiding spilling or dripping electrolyte.
5. Use proper jump start procedure.

If you spill acid on yourself:

1. Flush your skin with water.
2. Apply baking soda or lime to help neutralize the acid.
3. Flush your eyes with water for 15—30 minutes. Get medical attention immediately.

If acid is swallowed:

1. Do not induce vomiting.
2. Drink large amounts of water or milk, but do not exceed 2 L (2 quarts).
3. Get medical attention immediately.

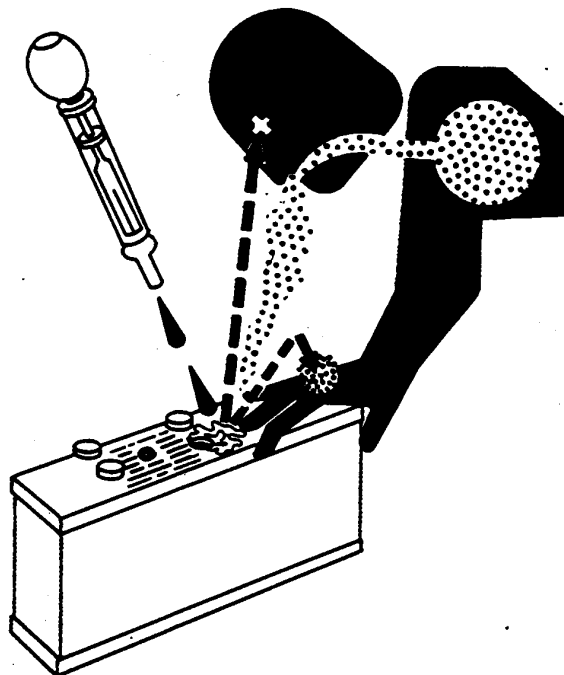

TS203—UN—23AUG88

OUTJ002,00004AB-19-29AUG07-1/1

Remove Paint Before Welding or Heating

Hazardous fumes can be generated when paint is heated by welding or using a torch. Dust from sanding or grinding paint can also be hazardous.

Remove paint to at least 76 mm (3 in.) from area to be heated. Wear an approved respirator when sanding or grinding paint. If a solvent or paint stripper is used, wash area with soap and water. Remove solvent or paint stripper containers from work area and allow fumes to disperse at least 15 minutes before welding or heating.

Work outside or in a well-ventilated area. Dispose of waste, paint and solvents properly.



T133546—UN—24AUG00

TX03679,0001732-19-28FEB06-1/1

Switch Panel

1. Rear Work Light Switch: When switch is ON, both rear work lights come on.

2. Accessory Power Port: 12-volt 10-amp electrical port provided for service and maintenance.

3. Lighter: For operator convenience. Can be used as an electrical port for service and maintenance for 24-volt appliances.

1—Rear Work Light Switch 3—Lighter
2—Accessory Power Port

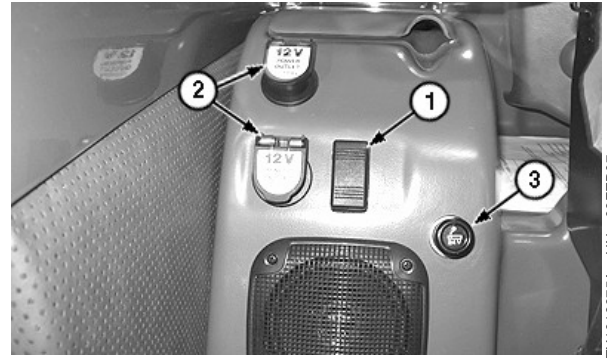

Side Entry Panel

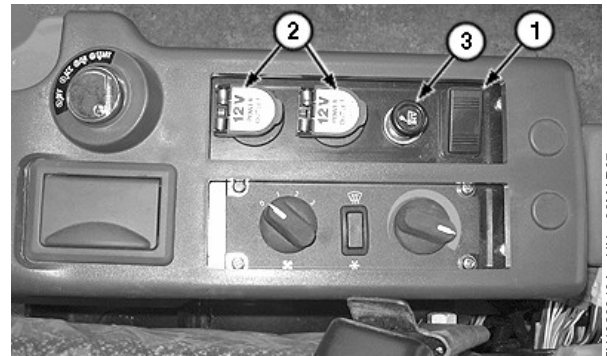

Rear Entry Panel

DW90712,0000564-19-13DEC07-1/1

Pilot Shutoff Lever

The pilot shutoff lever shuts off hydraulic pilot pressure to all pilot control valves. When pilot shutoff lever is in locked (UP) position, the machine will not move if a lever or pedal is accidentally moved. Engine will not start with pilot shutoff lever in the unlocked (DOWN) position.

Always pull pilot shutoff lever to locked (UP) position when stopping the engine or leaving operator's station.

Push pilot shutoff lever forward to unlocked (DOWN) position to operate machine.

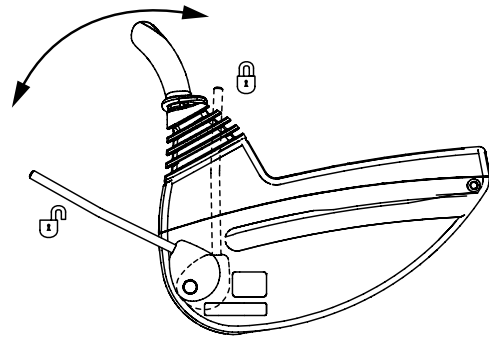

Pilot Shutoff Lever (unlocked position)

DW90712,00004D0-19-12APR16-1/1

Power Boost Button

Press and hold down power boost button for an 8 second increase in hydraulic power. Release button to reset power boost function.

Power boost is automatically activated when the following conditions are met:

- Boom Up
- No Arm In
- High Delivery Pressure

DW90712,00004CF-19-01FEB07-1/1

Hydraulic Oil Tank Pressure Vent—If Equipped

The purpose of this system is to provide the operator a method of minimizing oil leakage in the event of an oil line rupture or part failure. The hydraulic oil tank on the machine is fitted with a filler cap that allows a pressure of 48 kPa (0.48 bar) (7 psi) to be created inside the tank. The purpose of this pressure is to maintain a positive pressure on the suction side of the main pumps to prevent pump cavitation. The downside effect of this pressure is that hydraulic oil will continue to leak until the operator vents this pressure.

The system incorporates a hydraulic oil tank pressure vent solenoid (1) that bypasses the cap and provides an electrically controlled method for venting the tank pressure. A hydraulic oil tank pressure vent switch (2) (momentary push-button switch) on the left console, in the cab operates this valve. To prevent inadvertent actuation and possible pump cavitation, the controls are electrically interlocked with the key switch so that key switch must be in OFF position before the system can be activated.

- 1—Hydraulic Oil Tank Pressure Vent Solenoid 2—Hydraulic Oil Tank Pressure Vent Switch

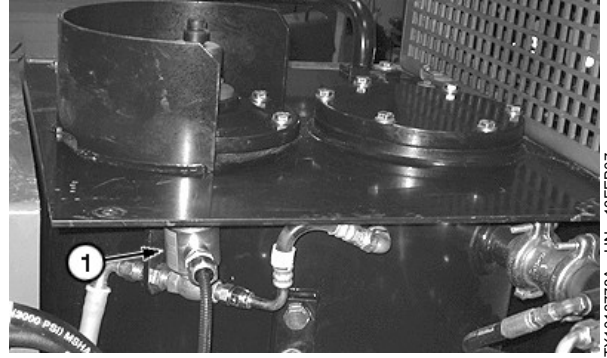

TX1018778A—UN—13FEB07

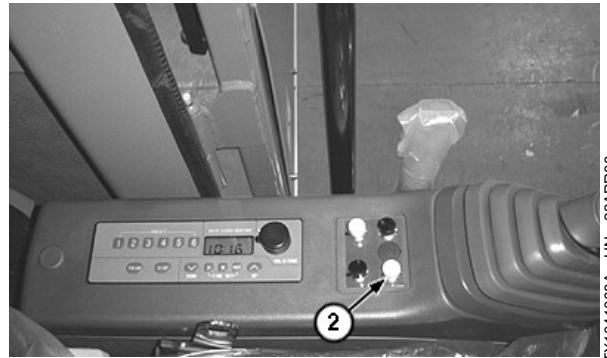

TX1041068A—UN—22APR08

Hydraulic Oil Tank Pressure Vent Switch-Side Entry Cab Shown

DW90712,0000570-19-14OCT08-1/1

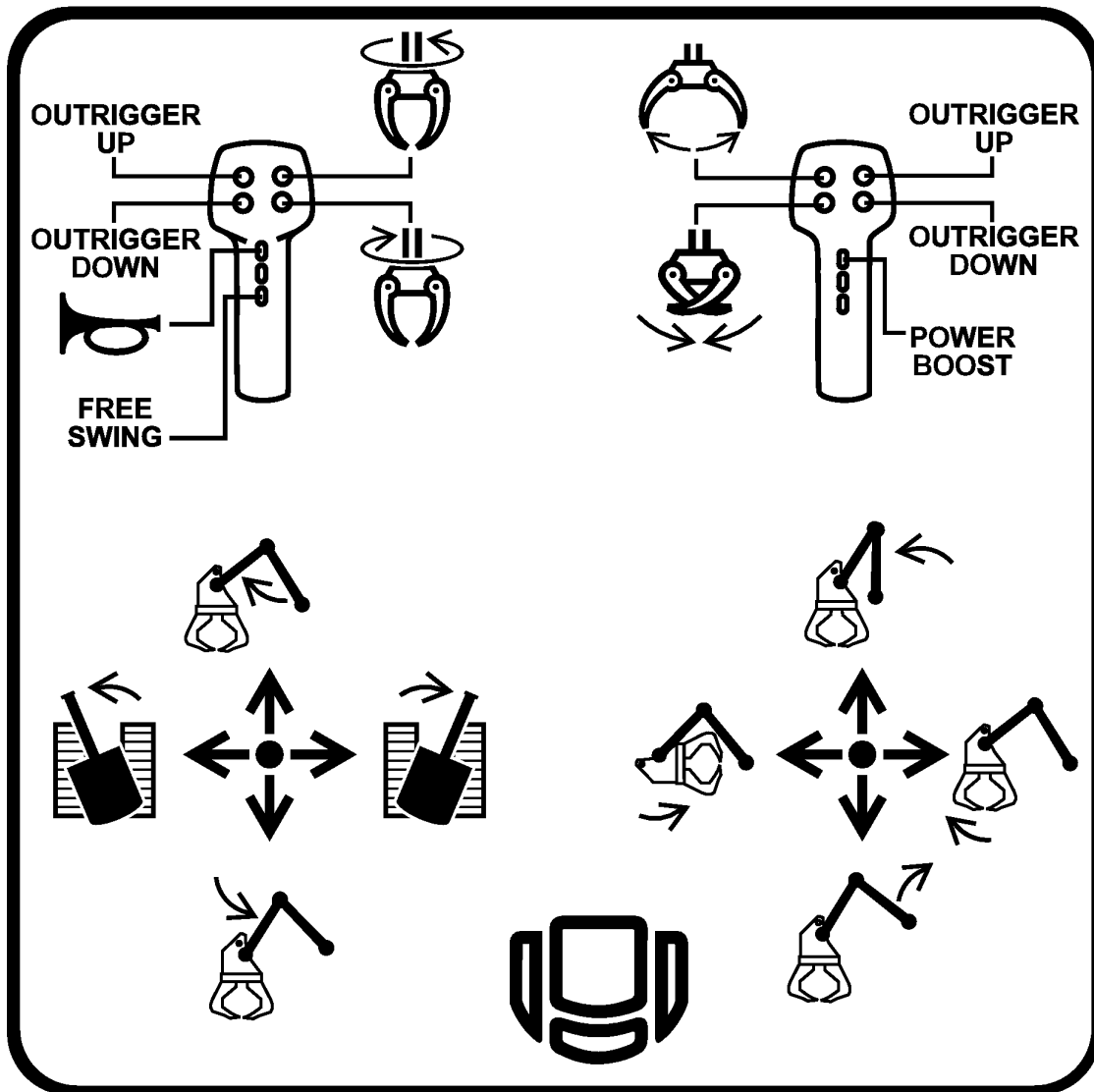

TX1030604

Control Lever Pattern—Butt-N-Top Grapple With Valve-In-Head

DW90712,000063B-19-19JUN08-2/2

TX1030604—19—25OCT07

(including copper, lead, zinc, tin, brass, and bronze) used in fuel handling, distribution, and storage equipment

- Possible reduction in water separator efficiency
- Possible damage to paint if exposed to biodiesel
- Possible corrosion of fuel injection equipment
- Possible elastomeric seal and gasket material degradation (primarily an issue with older engines)
- Possible high acid levels within fuel system

- Because biodiesel blends above B20 contain more ash, using blends above B20 can result in more rapid ash loading and require more frequent cleaning of the Exhaust Filter (if present)

IMPORTANT: Raw pressed vegetable oils are NOT acceptable for use as fuel in any concentration in John Deere engines. Their use could cause engine failure.

DX,FUEL7-19-13JAN18-2/2

Testing Diesel Fuel

A fuel analysis program can help to monitor the quality of diesel fuel. The fuel analysis can provide critical data such as calculated cetane index, fuel type, sulfur content, water content, appearance, suitability for cold weather operations, bacteria, cloud point, acid number, particulate

contamination, and whether the fuel meets ASTM D975 or equivalent specification.

Contact your John Deere dealer for more information on diesel fuel analysis.

DX,FUEL6-19-13JAN18-1/1

Engine Break-In Oil

IMPORTANT: Do not use John Deere PLUS-50® oil or engine oils meeting API CG4, API CF4, or CCMC D5 performance levels during the first 250 hours of operation of a new or rebuilt engine. These oils will not allow the engine to break-in properly.

New engines are filled at the factory with John Deere ENGINE BREAK-IN OIL.

Change the oil and filter after the first 250 hours of operation of a new or rebuilt engine.

PLUS-50 is a trademark of Deere & Company.

After engine overhaul, fill the engine with John Deere ENGINE BREAK-IN OIL.

If John Deere ENGINE BREAK-IN OIL is not available, use a diesel engine oil with oil viscosity based on the expected air temperature range, and meeting one of the following, during the first 250 hours of operation:

- API Service Classification
- CCMC Specification D4

After the break-in period, use John Deere PLUS-50® or other diesel engine oil as recommended in this manual.

DW90712,0000505-19-31JAN07-1/1

Diesel Engine Oil — Tier 3 and Stage IIIA

Failure to follow applicable oil standards and drain intervals can result in severe engine damage that might not be covered under warranty. Warranties, including the emissions warranty, are not conditioned on the use of John Deere oils, parts, or service.

Use oil viscosity based on the expected air temperature range during the period between oil changes.

John Deere Plus-50™ II oil is preferred.

John Deere Plus-50™ is also recommended.

John Deere Torq-Gard™ is also allowed.

Other oils may be used if they meet one or more of the following standards:

- API Service Category CK-4
- API Service Category CJ-4
- API Service Category CI-4 PLUS
- API Service Category CI-4
- ACEA Oil Sequence E9
- ACEA Oil Sequence E7
- ACEA Oil Sequence E6
- ACEA Oil Sequence E5
- ACEA Oil Sequence E4

Multi-viscosity diesel engine oils are preferred.

Diesel fuel quality and fuel sulfur content must comply with all existing emissions regulations for the area in which the engine operates.

Plus-50 is a trademark of Deere & Company
Torq-Gard is a trademark of Deere & Company

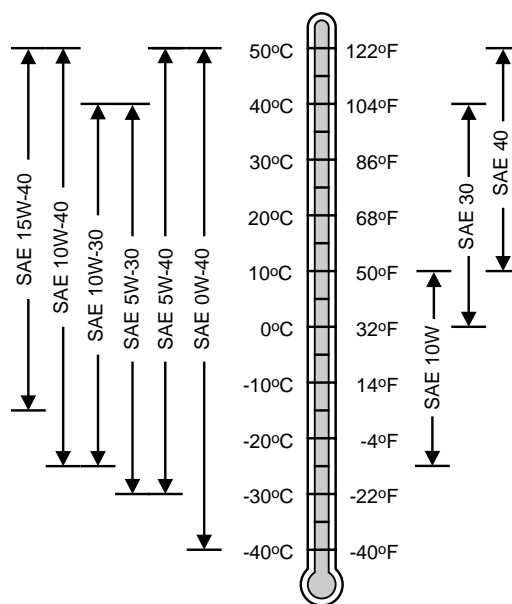

Oil Viscosities for Air Temperature Ranges

DO NOT use diesel fuel with sulfur content greater than 10 000 mg/kg (10 000 ppm).

TS1743—UN—25APR19

DX,ENOIL11-19-23APR19-1/1

Open Engine Cover for Service

CAUTION: Prevent personal injury from heavy door closing. Unlock latch. Pull open latches to unlock cover. Raise the cover until the end of the bar is securely locked into catch.

Raise cover using handle on cover until the end of the rod is securely locked into catch (1).

1—Catch

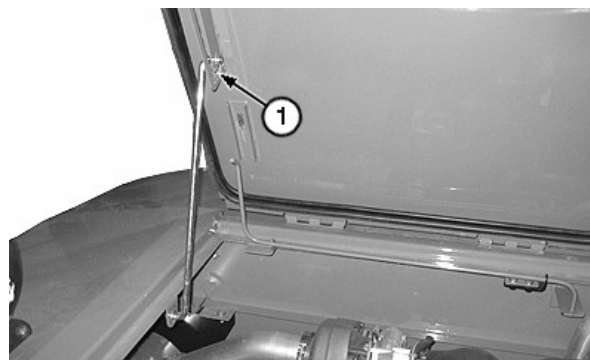

TX1019099A—UN—15FEB07

DW90712,0000584-19-09OCT08-1/1

Fuel Tank

CAUTION: Handle fuel carefully. If the engine is hot or running, DO NOT fill the fuel tank. DO NOT smoke while filling fuel tank or working on fuel system.

IMPORTANT: If machine has been run out of fuel, engine will not start. Contact your authorized dealer for instructions.

To avoid condensation, fill the fuel tank at the end of each day's operation.

Specification

Fuel Tank—Capacity. 1050.0 L
277.0 gal

DW90712,0000585-19-28APR15-1/1

Fluid Analysis Program Test Kits and 3-Way Coolant Test Kit

Fluid Analysis Program Test Kits and the 3-Way Coolant Test Kit are John Deere fluid sampling products to help you monitor machine maintenance and system condition. The objective of a fluid sampling program is to ensure machine availability when you need it and to reduce repair costs by identifying potential problems before they become critical.

Engine, hydraulic, power train, and coolant samples should be taken from each system on a periodic basis, usually prior to a filter and/or fluid change interval. Certain systems require more frequent sampling. Consult your authorized John Deere dealer on a maintenance program for your specific application. Your authorized John Deere dealer has the sampling products and expertise to assist you in



Fluid Analysis Kits

lowering your overall operating costs through fluid sampling.

TX1003513A—UN—20FEB06

AM40430,00002FE-19-19OCT11-1/1

Maintenance—Every 10 Hours or Daily

Lubricate Front End Pin Joints

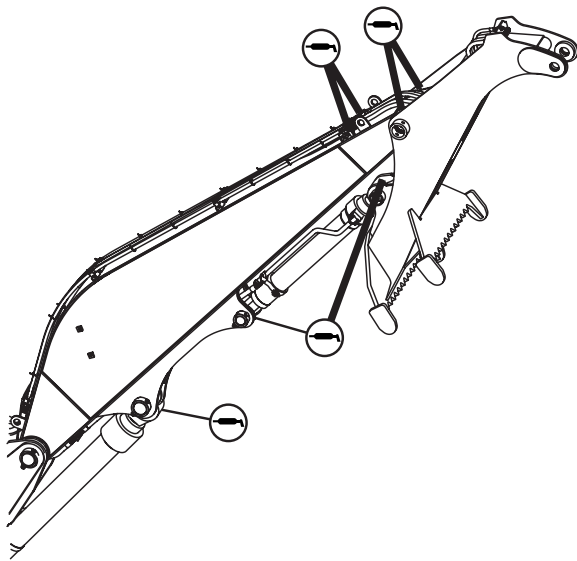

TX1041668—UN—07MAY08

7 Points with live heel

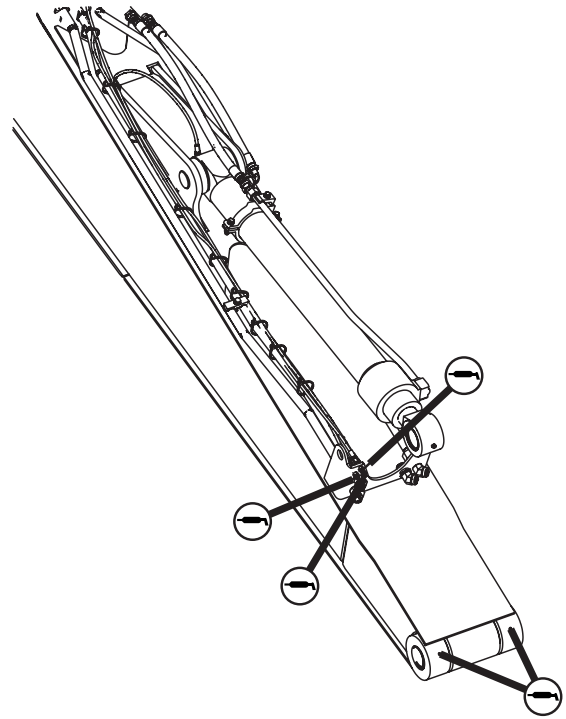

TX1041894—UN—07MAY08

5 Points with tilt cylinder

Lubricate front end pin joints (14 points with live heel, 12 points with tilt cylinder) until grease escapes from joints. Lubricate every 4 hours for first 20 hours. Lubricate every 10 hours during first 30—100 hours and when working in mud and water.

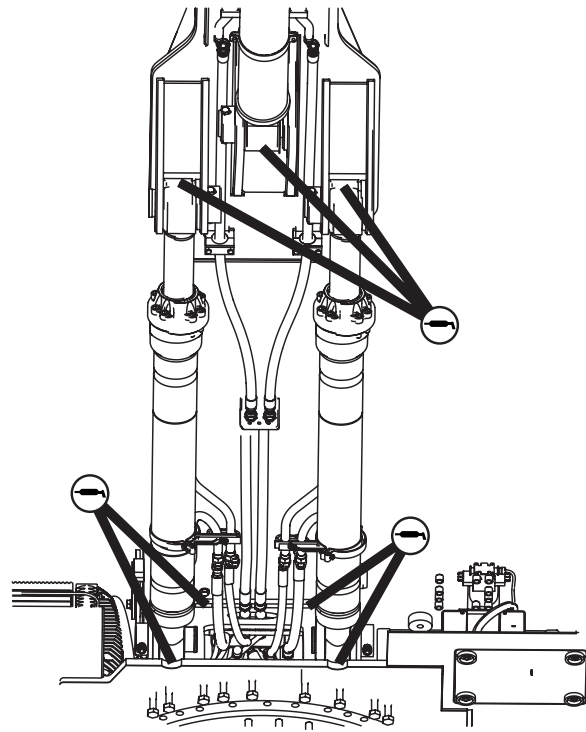

TX1041667—UN—01MAY08

7 Points

OUT4001.0000101-19-07JUN11-1/1

If equipped with pressure release button:

⚠ CAUTION: High pressure release of oil from pressurized system can cause serious burns or penetrating injury. The hydraulic tank is pressurized. Relieve pressure by pushing pressure release button (1).

1. Stop engine.
2. To relieve pressure, push the pressure release button (1).
3. Remove hydraulic oil tank cover (2).
4. After oil is cool, loosen sump plug (3) for several seconds to drain water and sediment into a container. Do not remove plug completely. Dispose of waste properly.
5. Tighten sump plug, and install hydraulic oil tank cover.

1—Pressure Release Button 3—Sump Plug
2—Hydraulic Oil Tank Cover

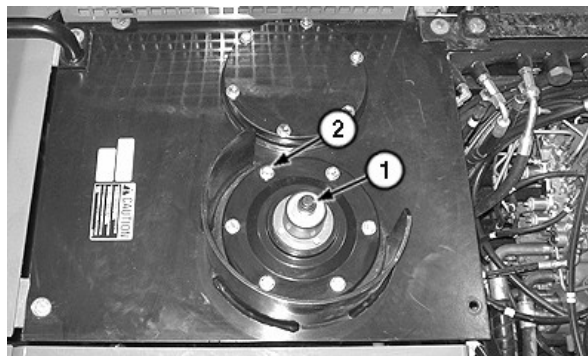

TX1019230A—UN—15FEB07

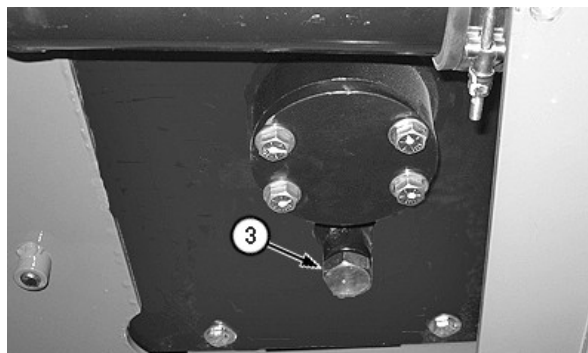

TX1019238A—UN—19FEB07

DW90712,0000588-19-06OCT11-2/2

Check Pump Drive Gear Case Oil Level

1. Remove dipstick (1).
2. Wipe dipstick clean and insert completely into tube.
3. Remove dipstick.
4. Oil must be approximately halfway below the "H" (level) mark. Insert dipstick.

To add oil:

1. Remove fill plug (2).
2. Add oil.
3. Install fill plug.

1—Dipstick 2—Fill Plug

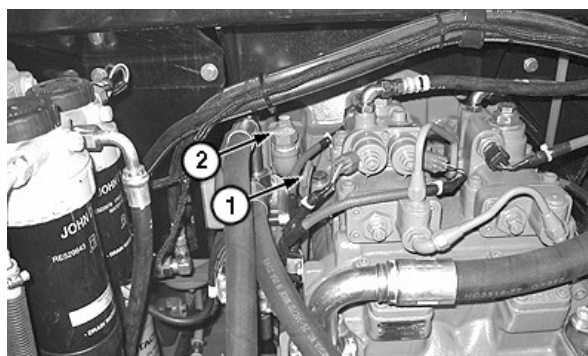

TX1019247A—UN—15FEB07

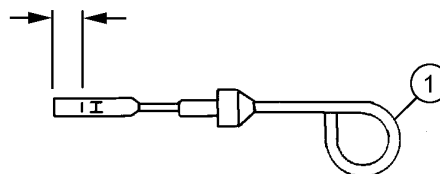

T145092—UN—31AUG01

DW90712,0000589-19-15FEB07-1/1

CLICK HERE TO **DOWNLOAD** THE COMPLETE MANUAL

- Thank you very much for reading the preview of the manual.
- You can download the complete manual from: www.heydownloads.com by clicking the link below



- Please note: If there is no response to CLICKING the link, please download this PDF first and then click on it.

CLICK HERE TO **DOWNLOAD** THE COMPLETE MANUAL

If equipped with hydraulic tank cap:

⚠ CAUTION: High pressure release of oil from pressurized system can cause serious burns or penetrating injury. The hydraulic tank is pressurized. Relieve pressure by slowly turning the cap (4) counterclockwise a few degrees.

1. Insert 4 mm hex wrench (11) into hole (12) and turn counterclockwise to release locking pin.
2. Slowly turn cap (4) counterclockwise a few degrees to relieve pressure. Remove cap.

If equipped with pressure release button:

⚠ CAUTION: High pressure release of oil from pressurized system can cause serious burns or penetrating injury. The hydraulic tank is pressurized. **DO NOT** remove hydraulic cap. Relieve pressure by pushing the pressure release button (1).

To release pressure, push the pressure release button (1).

- | | |
|---------------------------|------------------|
| 1—Pressure Release Button | 9—Aligning Mark |
| 2—Filter cover | 10—Case Assembly |
| 3—Cap Screw (6 used) | 11—Wrench |
| 4—Hydraulic Tank Cap | 12—Hole |

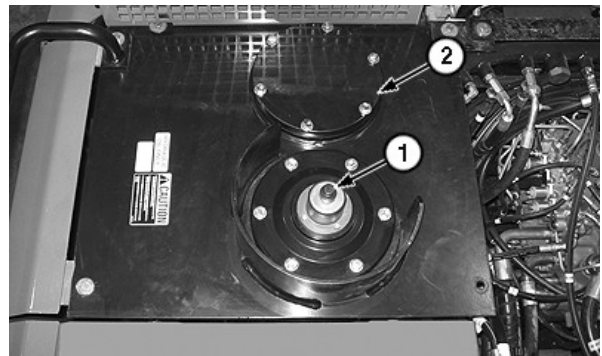
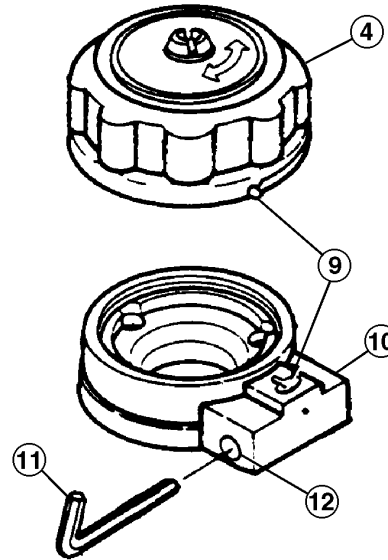
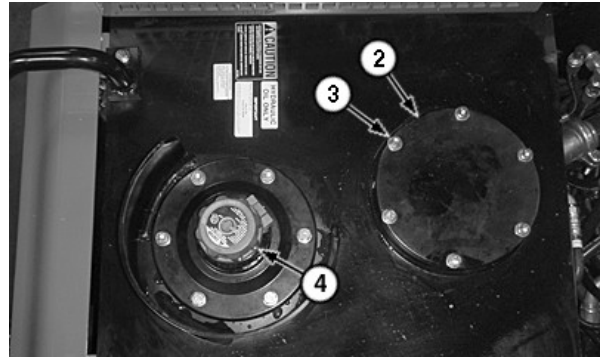

Continued on next page

OUT4001,0000186-19-07OCT11-2/3

- Remove drain plug (9). Allow oil to drain into a container. Dispose of waste oil properly.

Specification

Hydraulic Tank—Oil Capacity. 147.6 L
 39.0 gal

NOTE: The hydraulic oil filter and pilot oil filter can be changed at this point in the procedure. See Maintenance—Every 1000 Hours. (Section 3-10.)

- Remove suction screen.
- Clean inside of tank and suction screen.
- Install suction screen with cover. Suction screen must seal against outlet pipe in bottom of tank. If necessary, loosen nut (11) to adjust rod length.

Specification

Suction Screen Rod (1)—Length. 869 mm
 34.2 in.

Suction Screen Rod Nut—Torque. 14.7—19.6 N·m
 10.8—14.5 lb·ft

Hydraulic Cover Cap Screw—Torque 49 N·m
 36 lb·ft

- Install tank drain plug and bottom guard.
- Add oil until it is between marks on sight glass.

IMPORTANT: If the hydraulic pump is not filled with oil, it will be damaged when the engine is started.

- Remove air bleed plugs (12) from hydraulic pump until oil flows from bleed holes.
- Install air bleed plugs in hydraulic pump.
- Check oil level in sight glass. Add oil if necessary. Install and tighten tank cover.
- Purge air from cylinders and swing motor by cycling hydraulic functions.

- | | |
|-----------------------|---------------------------|
| 9—Drain Plug | 11—Suction Screen Rod Nut |
| 10—Suction Screen Rod | 12—Bleed Plug (2 used) |

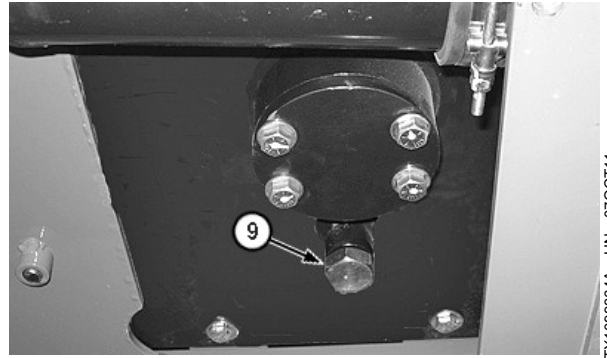

TX1099364A—UN—07OCT11

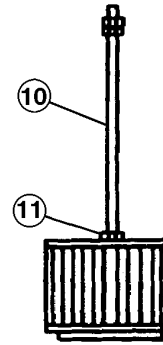

TX1099366—UN—10OCT11

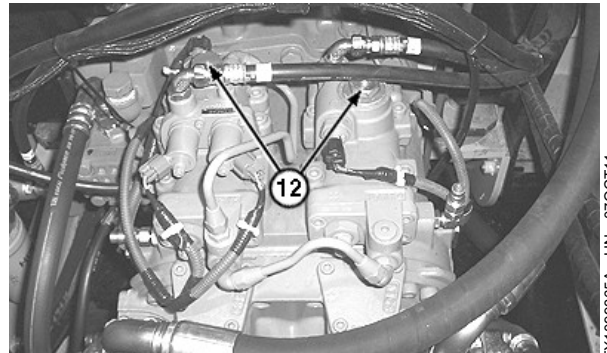

TX1099365A—UN—07OCT11

MB60223,000025B-19-24APR15-3/3

Miscellaneous—Machine

Inspect and Clean Polycarbonate Windows

Polycarbonate windows are important for the protection of the operator and the safe operation of the machine. Inspect the windows system regularly, and if surface crazing or cracks are observed, replace windows using only John Deere replacement parts to ensure the original operator protection level. Inspect the windows after any significant impact to the windows or frame.

NOTE: The use of cleaning agents, solvents, polishing compounds, or waxes not listed in this instruction block is not recommended. Contact an authorized dealer for additional information regarding glazing materials.

IMPORTANT: DO NOT use glass cleaners on polycarbonate windows.

NEVER use abrasive or highly alkaline cleaners on polycarbonate windows. Some cleaning compounds may attack the polycarbonate material, resulting in cracks.

NEVER use aromatic or halogenated solvents like toluene, benzene, acetone, tetrachloride, or petroleum products. Gasoline should not be used.

Acceptable cleaning agents are John Deere Polycarbonate Cleaner and John Deere Polycarbonate Wash.

Acceptable soap based cleaning agents are Joy®, Palmolive® Liquid, and Scott® Pink Lotion Skin Cleanser.

Cleaning should never be done in direct sunlight or at high temperatures, as this can lead to staining.

Before washing or applying any cleaning agents or solvents, inspect the hard coating of window for microcrazing or cracking. Do NOT apply solvents or cleaning agents to window with microcrazing or cracks.

Minor scratches and abrasions can be minimized by using a buffing compound or polish agent like NOVUS 1 or 2. Test any intended polishing product in a small area before using on the entire window. All polishing should follow the manufacturer's instructions to prevent further damage to the window's hard coat.

To begin the cleaning process, flush away as much loose dirt as possible with water, then clean the windows using a solution of approved cleaner and lukewarm water. Use a soft, grit-free cloth or sponge to loosen any dirt or grime. Never scrub with brushes, steel wool, or other abrasive materials. Never use squeegees, razor blades, or other sharp instruments to remove deposits or spots. The

*Joy is a trademark of Procter & Gamble
Palmolive is a trademark of Colgate-Palmolive
Scott is a trademark of Kimberly-Clark Corporation*

windows are made of a polycarbonate material, which is less abrasion resistant than glass. The windows will scratch.

Use of incompatible cleaning materials can cause structural and/or surface damage.

IMPORTANT: Always rinse window with water prior to cleaning process.

The edges of polycarbonate sheet are not protected with an abrasion and chemical resistance coating. Do not allow cleaning solutions and solvents to pool along the edges at any time. Always rinse edges thoroughly with generous amounts of clean, lukewarm water.

CAUTION: Make sure the work area is well ventilated when working with organic solvents.

Solvent fumes can be hazardous to health if proper safety precautions are not taken.

Do not smoke around organic solvents. Solvents can cause risk of fire if proper safety precautions are not taken.

For all mentioned chemicals, consult the manufacturer's material safety data sheet (MSDS) for proper safety precautions.

Masking adhesive and glazing compounds can be removed by applying Isopropyl Alcohol or Naphtha VM&P grade to a soft cloth and rubbing lightly; additionally, any of these cleaning agents or butyl cellosolve can be used to remove paints, marking pen inks, lipstick, or other forms of graffiti. Afterwards, wash the window using a solution of approved cleaner and lukewarm water. Rinse thoroughly to remove any trace of solvents.

Masking tape and adhesive tape work well for lifting off old, weathered paints.

To remove labels and stickers, the use of kerosene is generally effective. If the solvent does not penetrate the sticker material, apply heat using a hair dryer to soften the adhesive and promote removal. Afterwards, wash the window using a solution of approved cleaner and lukewarm water. Rinse thoroughly to remove any trace of solvents.

To remove tree sap, flush away as much loose dirt as possible, then use John Deere Polycarbonate Cleaner, kerosene, or Naphtha VM&P grade on a soft cloth and rub lightly. Rinse well with clean water and dry with a chamois or softer cloth to prevent water spotting.

MB60223,0000088-19-11MAY17-1/1

7. The single or four parameter screen will display the warning icon until the trouble code condition is corrected.

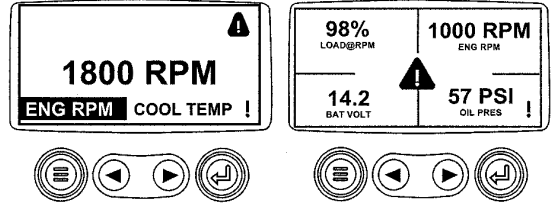

Active Trouble Code Condition

VD76477,00015EF-19-22AUG07-7/7

RG13243—UN—01OCT03

Adjusting Backlighting

1. Turn the key switch to the ON position. Starting at the single or four engine parameter display, press the menu key.

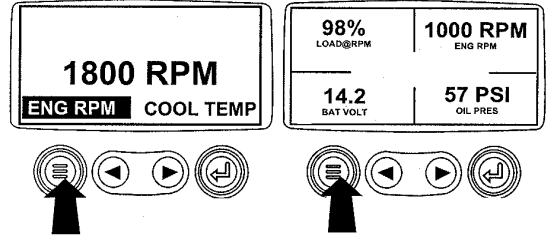

Menu Key

VD76477,00015F4-19-22AUG07-1/6

RG13159—UN—26SEP03

2. The main menu will be displayed. Use the arrow keys to scroll through the menu until Adjust Backlight is highlighted.

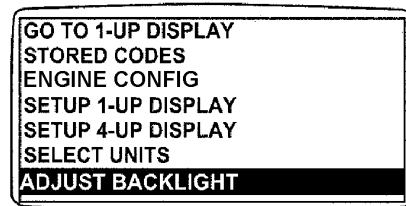

Select Adjust Backlight

VD76477,00015F4-19-22AUG07-2/6

RG13181—UN—02OCT03

3. Once the Adjust Backlight menu item has been highlighted, press the enter key to activate the Adjust Backlight function.

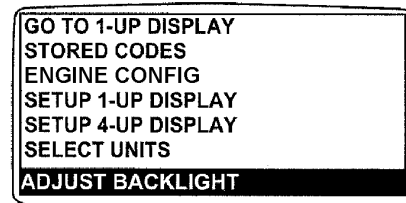

Press Enter Key

VD76477,00015F4-19-22AUG07-3/6

RG13182—UN—02OCT03

Continued on next page

17. Press the enter key again to toggle the Automatic Scan function off.

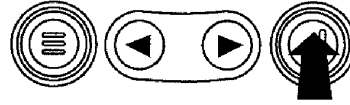
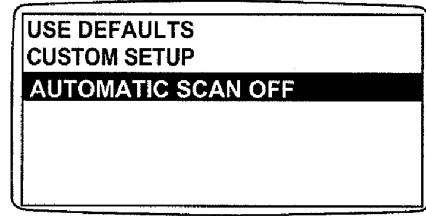

Automatic Scan Off

RG13223—UN—26SEP03

VD76477,00015F7-19-22AUG07-16/18

18. Once the Use Defaults, Custom Setup and Automatic Scan functions have been set, press the menu key to return to the main menu.

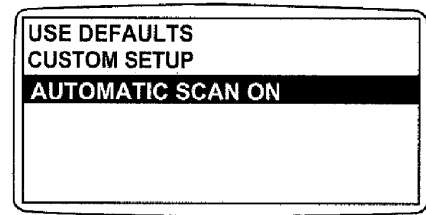

Menu Key

RG13224—UN—26SEP03

VD76477,00015F7-19-22AUG07-17/18

19. Press the menu key to exit the main menu and return to the engine parameter display.

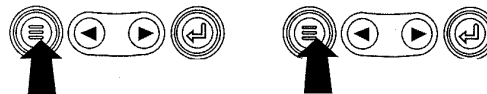
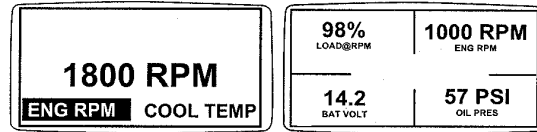

Exit Main Menu

RG13159—UN—26SEP03

VD76477,00015F7-19-22AUG07-18/18

Setup 4-Up Display

1. Turn the key switch to the ON position. From the single or four engine parameter display, press the menu key.

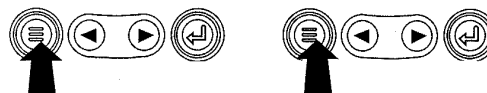
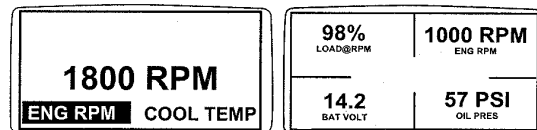

Menu Key

RG13159—UN—26SEP03

Continued on next page

VD76477,00015F8-19-22AUG07-1/14

Fuse Block 2

- | | |
|---|-------------------------------------|
| F21—Front Cab Work Lights 15 A Fuse | F30—Front Attachment 10 A Fuse |
| F22—Front Cab Work Lights 15 A Fuse | F31—Rear Cab Work Lights 15 A Fuse |
| F23—12 Volt Option 30 A Fuse | F32—Not Used |
| F24—12 Volt Power Outlet 20 A Fuse | F49—Seat Compressor 10 A Fuse |
| F25—12 Volt Option 10 A Fuse | F50—Seat Heater 10 A Fuse |
| F26—12 Volt Option 10 A Fuse | F51—24 Volt Option Plug 1 10 A Fuse |
| F27—Windshield Wiper (rear entry cab) 20 A Fuse | F52—24 Volt Option Plug 2 10 A Fuse |
| F28—Not Used | F53—24 Volt Option Plug 3 10 A Fuse |
| F29—Cab Fan 10 A Fuse | F54—Not Used |

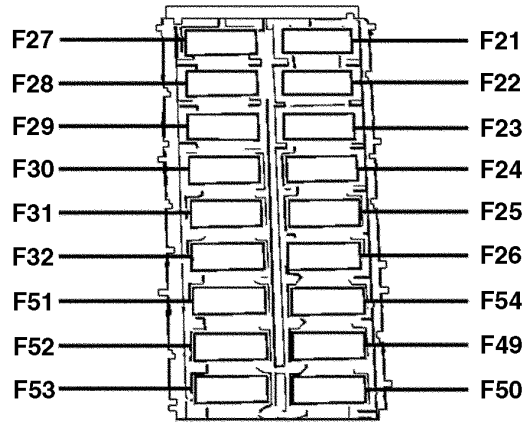

TX1041282

Fuse Block 2

TX1041282—UN—28APR08

DW90712,0000543-19-05JAN11-3/7

- | | |
|---|--|
| F34—Engine Control Unit (ECU) 20 A Fuse | F35—Service Advisor Connector 5 A Fuse |
|---|--|

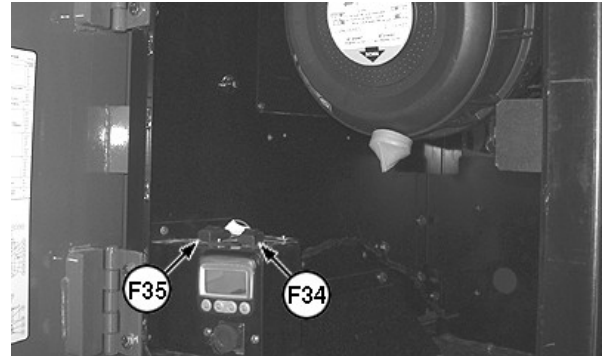

TX1041322A—UN—01MAY08

Continued on next page

DW90712,0000543-19-05JAN11-4/7

LOOK: Does auto-idle indicator light (17) and/or auto-acceleration indicator light (18) illuminate, depending on switch position?

LOOK: Does dig mode indicator light (14) or attachment mode indicator (15) illuminate, depending on switch position?

LOOK: After 2—3 seconds does only the alternator voltage indicator light (8), engine oil pressure indicator light (11), and dig or attachment mode indicator light remain ON?

LOOK: Does check engine indicator light (9) go OFF?

LB82152,00004F9-19-16OCT13-8/52

Horn Circuit Check

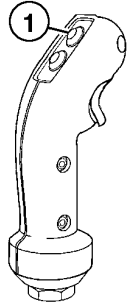

**LEFT
CONTROL LEVER**

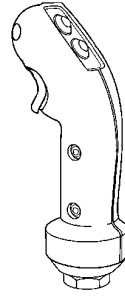

**RIGHT
CONTROL LEVER**

TX1021431—19—30APR07

Horn Switch—Non Valve-in-Head

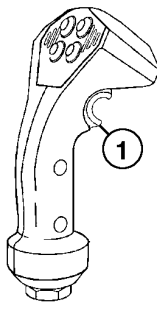

**LEFT
CONTROL LEVER**

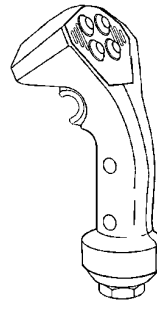

**RIGHT
CONTROL LEVER**

TX1021430—19—30APR07

Horn Switch—Valve-in-Head

1—Horn Switch

Key switch ON.

Engine OFF.

Push horn switch (1).

LISTEN: Does horn sound?

YES: Go to next check.

NO: Check horn 10 A fuse (F14) (marked HORN).

NO: See your authorized dealer.

Continued on next page

LB82152,00004F9-19-16OCT13-9/52

P (Standard) Mode Check



T7351CC—UN—22AUG90

LOCKED—Side Entry Shown

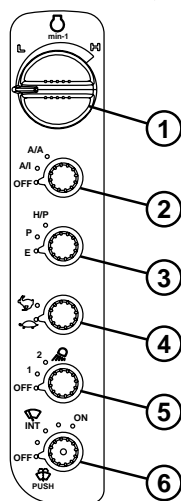

T142011—UN—10MAY01

Switch Panel

- 1—Engine Speed Dial
- 2—Auto-Idle/Auto-Acceleration Switch
- 3—Power Mode Switch
- 4—Travel Speed Switch
- 5—Work Light Switch
- 6—Windshield Wiper and Washer Switch

Engine running.

Pilot control shutoff lever in LOCKED position.

Auto-idle/auto-acceleration switch (2) OFF.

Turn engine speed dial (1) to H (fast idle) position.

Turn power mode switch (3) to E (economy) mode.

LISTEN: Does engine speed decrease?

Turn power mode switch from E (economy) to P (standard) mode.

LISTEN: Does engine speed increase?

YES: Go to next check.

NO: Check main controller (MCX) 5 A fuse (F2) (marked CONTROLLER).

NO: See your authorized dealer.

Continued on next page

LB82152,00004F9-19-16OCT13-21/52

Boom, Arm, and Attachment Drift Check

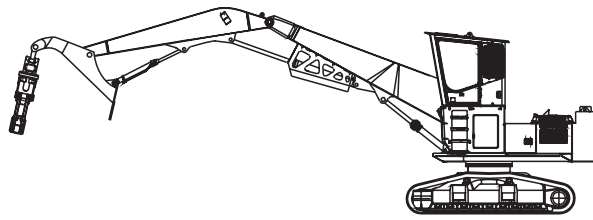

TX1041639—UN—02MAY08

Boom, Arm, and Attachment Drift Check—Live Heel Grapple

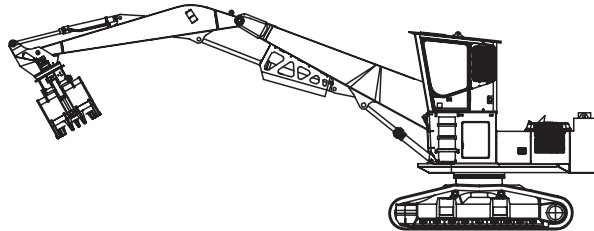

TX1021400—UN—12JUN07

Boom, Arm, and Attachment Drift Check—Articulated Grapple

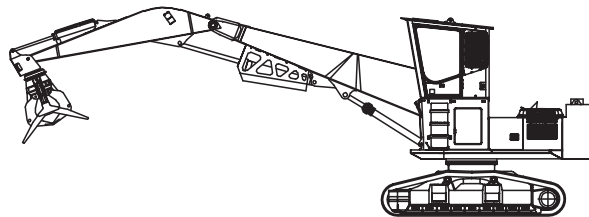

TX1021399—UN—12JUN07

Boom, Arm, and Attachment Drift Check—Butt-N-Top Grapple

⚠ CAUTION: Prevent possible injury from machine movement. Make sure area is clear of bystanders and large enough to operate all machine functions.

Position attachment at maximum reach with arm-to-attachment pivot pin the same height as boom pivot pin.

NOTE: Raise attachment to appropriate height to ensure that attachment does not settle to the ground during test. If attachment settles to ground during time limit, raise attachment to a higher level and repeat test.

Retract grapple tilt cylinder (heel cylinder) to relief then extend approximately 2 inches. Stop engine.

Measure and record current length of boom cylinder, arm cylinder, and grapple tilt cylinder (heel cylinder).

Measure distance from bottom of grapple to ground.

Wait 5 minutes

YES: Go to next check.

NO: See your authorized dealer.

Continued on next page

LB82152,00004F9-19-16OCT13-34/52

Cycle Times Check—
2954D (S.N. —290132)

CAUTION: Prevent possible injury from unexpected machine movement. Clear all persons from the area before operating machine.

IMPORTANT: Prevent possible machine damage. Remove attachment before performing cycle times check.

NOTE: Warm hydraulic oil to operating temperature for this check.

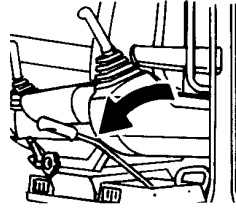

T7351CB—UN—22AUG90

UNLOCKED—Side Entry Shown

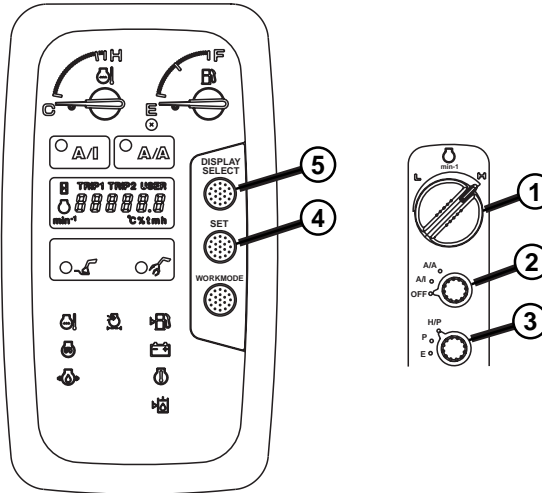

TX1142391

TX1142391—UN—15AUG13

Monitor and Switch Panel

- 1—Engine Speed Dial
- 2—Auto-Idle/Auto-Acceleration Switch
- 3—Power Mode Switch
- 4—Set Switch
- 5—Display Select Switch

NOTE: Machines with serial number less than or equal to 290132 may be equipped with an updated main controller (MCX), which will affect machine operation in HP (high power) mode. The following check must be performed to determine if machine has updated main controller.

Check for updated main controller:

- Key switch in OFF position.
- Monitor in user mode.
- Start engine.
- Set monitor to display engine speed.
- Pilot control shutoff lever in UNLOCKED (forward) position.
- Auto-idle/auto-acceleration switch (2) in OFF position.
- Engine speed dial (1) in H (fast idle) position.

Move power mode switch (3) to HP (high power) mode.

LISTEN/LOOK: Does engine speed increase as power mode switch is moved to HP (high power) mode?

YES: Continue this check.

NO: Go to Cycle Times Check—2954D (S.N. 290132 —).

Continued on next page

LB82152,00004F9-19-16OCT13-45/52

Symptom	Problem	Solution
	Loose surge tank cap	Secure cap properly.
	Incorrect engine oil	Use correct oil.
	Variable speed fan	See authorized dealer.
Engine Uses Too Much Fuel	Clogged or dirty air intake system	Clean air intake system.
	Incorrect fuel	Use correct fuel.
	Engine running too cool	Replace thermostat.
Engine Emits Excessive Black or Gray Exhaust Smoke	Incorrect fuel	Use correct fuel.
	Clogged or dirty air intake or exhaust system	Clean air intake and exhaust system.
Engine Emits Excessive White Exhaust Smoke	Incorrect fuel	Use correct fuel.
	Cold engine	Run engine until warm.

DW90712,0000547-19-03JUL08-3/3

Keep Machines Secure

1. Install vandal-proof devices.
2. When machine is in storage:
 - Lower equipment to the ground
 - Set tracks to widest position to make loading more difficult
 - Remove any keys and batteries
3. When parking indoors, put large equipment in front of exits and lock storage buildings.
4. When parking outdoors, store in a well-lighted and fenced area.
5. Make note of suspicious activity and report any thefts immediately to law enforcement agencies.
6. Notify your John Deere dealer of any losses.

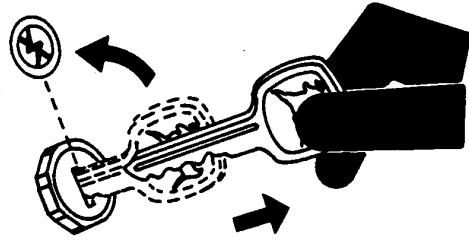

TS230—UN—24MAY89

DW90712,000054D-19-26MAY10-1/1

Index

	Page		Page
A			
Accessory		Attachments	
Electrical	4-1-30	Adding safely	1-3-5
Accessory power port	2-1-7	Operating safely	1-3-5
Acid burns	3-8-5	Auto-acceleration	
Adjustment		Indicator	2-1-3
Armrest	2-1-14	Switch	2-1-6
Belt tension	3-10-7	Auto-acceleration	
Seat	2-1-14	Circuit, operational check	4-2-18
Track sag	3-3-5	Auto-idle	
Air		Indicator	2-1-3
Intake hoses	3-9-3	Switch	2-1-6
Air cleaner		Auto-idle	
Clean	3-10-8	Circuit, operational check	4-2-17
Dust unloader valve	3-3-2	Auxiliary fuel filter and water separator	
Dust unloader valve replacement	3-10-8	Drain	3-3-6
Replace	3-10-8	B	
Air conditioner	2-1-9	Backover accidents	
Rear entry cab	2-1-10	Avoiding	1-3-4
Air conditioner belt		Batteries	
Check and adjust	4-1-2	Using battery charger	4-1-28
Air filter		Battery	
Clean	3-10-8	Acid burns	3-8-5
Replace	3-10-8	Booster batteries	4-1-26
Air filter restriction		Electrolyte level check	3-8-5
Indicator	2-1-3	Explosion	3-8-5
Air inlet screen		Safety	4-1-27
Cleaning	3-3-3	Specification	4-1-29
Air suspension seat		Terminals	3-8-5
Adjusting	2-1-15	Battery disconnect	
Alternator		Relay, operational check	4-2-3
Precaution	4-1-3	Battery explosions	
Alternator voltage		Prevent	1-2-5
Indicator	2-1-3	Before starting work	2-2-1
Arm		Belt	
Lubricate	3-4-1	Tension adjust	3-10-7
Arm		Belt tension	
Regenerative valve, operational check	4-2-28	Air conditioner	4-1-2
Arm drift		Biodiesel fuel	3-1-3
Operational check	4-2-24	Bleed	
Armrest		Fuel system	4-1-2
Adjustment	2-1-14	Bolt and screw torque values	
Articulated grapple with valve-in-head		Metric	4-1-37
Control levers	2-2-7	Unified inch	4-1-36
Articulated grapple with valve-in-head		Boom	
Control lever switches	2-1-2	Lubricate	3-4-1
Articulated grapple/valve in head		Boom drift	
Control levers	2-2-9	Operational check	4-2-24
Attachment drift		Boom lower	
Operational check	4-2-24	With engine stopped	2-2-13
Attachment mode		Boost starting	4-1-26
Indicator	2-1-3		

Continued on next page

CLICK HERE TO **DOWNLOAD** THE COMPLETE MANUAL

- Thank you very much for reading the preview of the manual.
- You can download the complete manual from: www.heydownloads.com by clicking the link below



- Please note: If there is no response to CLICKING the link, please download this PDF first and then click on it.

CLICK HERE TO **DOWNLOAD** THE COMPLETE MANUAL