

2654G and 2654GLC Forestry Excavator

(PIN: 1FF2654G__C260001—)

(PIN: 1FF2654G__D260001—)



OPERATOR'S MANUAL

2654G and 2654GLC Forestry Excavator

OMT388074X19 ISSUE A3 (ENGLISH)

CALIFORNIA

Proposition 65 Warning

Diesel engine exhaust and some of its constituents are known to the State of California to cause cancer, birth defects, and other reproductive harm.

If this product contains a gasoline engine:

⚠ WARNING

The engine exhaust from this product contains chemicals known to the State of California to cause cancer, birth defects or other reproductive harm.

The State of California requires the above two warnings.

**Worldwide Construction
And Forestry Division**

PRINTED IN U.S.A.

CLICK HERE TO **DOWNLOAD** THE COMPLETE MANUAL

- Thank you very much for reading the preview of the manual.
- You can download the complete manual from: www.heydownloads.com by clicking the link below



- Please note: If there is no response to CLICKING the link, please download this PDF first and then click on it.

CLICK HERE TO **DOWNLOAD** THE COMPLETE MANUAL

Emissions Control System Certification Label

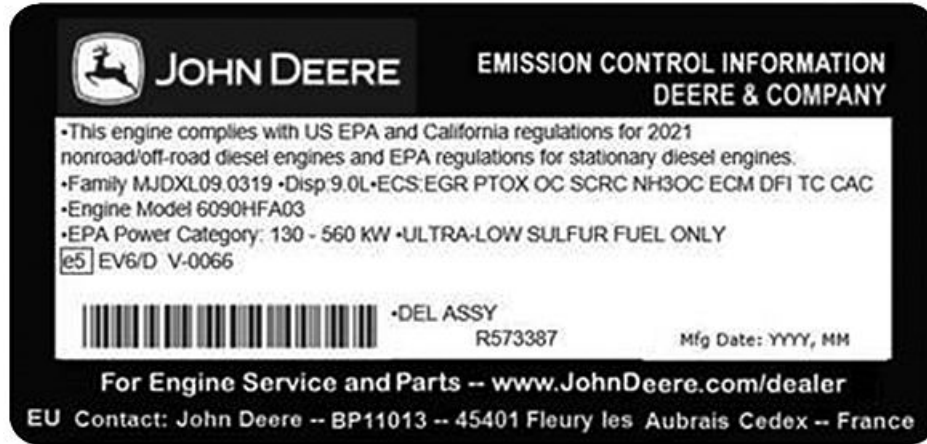

Engine Emissions Label

⚠ CAUTION: Statutes providing severe penalties for tampering with emissions controls may apply to the user or dealer.

The emissions warranty applies to those engines marketed by John Deere that have been certified by the United States Environmental Protection Agency (EPA) and/or California Air Resources Board (CARB); and used in the United States and Canada in Non-road equipment. The presence of an emissions label like the one shown signifies that the engine has been certified with the EPA and/or CARB. The EPA and CARB warranties only apply to new engines having the certification label affixed to the engine and sold as stated above in the geographic areas. The presence of an EU number signifies that the engine has been certified with the European Union countries per Regulation (EU) 2016/1628 and supplementing legislation. The EPA and/or CARB emissions warranties do not apply to the EU countries.

The emissions label has applicable US EPA and/or CARB regulatory year. The regulatory year determines which warranty statement is applicable to engine. See “EPA Non-road Emissions Control Warranty Statement—Compression Ignition” and “CARB Non-road Emissions Control Warranty Statement—Compression Ignition”. For additional regulatory year warranty statements, see www.JohnDeere.com or contact the nearest John Deere service dealer for assistance.

Emission Control System(s) Laws

The U.S. EPA and California ARB prohibit the removal or rendering inoperative of any device or element of design installed on or in engines/equipment in compliance with applicable emission regulations prior to or after the sale and delivery of the engines/equipment to the ultimate purchaser.

DX,EMISSIONS,LABEL -19-05FEB21-1/1

RG33429—UN—04FEB21

JOHN DEERE'S WARRANTY RESPONSIBILITY:

Where a warrantable condition exists, John Deere will repair or replace, as it elects, your off-road diesel engine at no cost to you, including diagnosis, parts or labor. Warranty coverage is subject to the limitations and exclusions set forth herein. The off-road diesel engine is warranted for a period of five years from the date the engine is delivered to an ultimate purchaser or 3,000 hours of operation, whichever occurs first. The following are emissions-related parts:

<p>Air Induction System</p> <ul style="list-style-type: none"> • Intake manifold • Turbocharger • Charge air cooler <p>Fuel Metering system</p> <ul style="list-style-type: none"> • Fuel injection system <p>Exhaust Gas Recirculation</p> <ul style="list-style-type: none"> • EGR valve <p>Catalyst or Thermal Reactor Systems</p> <ul style="list-style-type: none"> • Catalytic converter • Exhaust manifold 	<p>Emission control labels</p> <p>Particulate Controls</p> <ul style="list-style-type: none"> • Any device used to capture particulate emissions • Any device used in the regeneration of the capturing system • Enclosures and manifolding • Smoke Puff Limiters <p>Positive Crankcase Ventilation (PCV) System</p> <ul style="list-style-type: none"> • PCV valve • Oil filler cap 	<p>Advanced Oxides of Nitrogen (NOx) Controls</p> <ul style="list-style-type: none"> • NOx absorbers and catalysts <p>SCR systems and urea containers/dispensing systems</p> <p>Miscellaneous Items used in Above Systems</p> <ul style="list-style-type: none"> • Electronic control units, sensors, actuators, wiring harnesses, hoses, connectors, clamps, fittings, gasket, mounting hardware
--------------------------------------------------------------------------------------------------------------------------------------------------------------------------------------------------------------------------------------------------------------------------------------------------------------------------------------------------------------------------------------------------------------------------------------------------------------------------------------------------------------------------------------	-----------------------------------------------------------------------------------------------------------------------------------------------------------------------------------------------------------------------------------------------------------------------------------------------------------------------------------------------------------------------------------------------------------------------------------------------------------------------------	------------------------------------------------------------------------------------------------------------------------------------------------------------------------------------------------------------------------------------------------------------------------------------------------------------------------------------------------------------------------------------------------------------------------------------------------------

Any warranted emissions-related part scheduled for replacement as required maintenance is warranted by John Deere for the period of time prior to the first scheduled replacement point for the part. Any warranted emissions-related part not scheduled for replacement as required maintenance or scheduled only for regular inspection is warranted by John Deere for the stated warranty period.

OWNER'S WARRANTY RESPONSIBILITIES:

As the off-road diesel engine owner you are responsible for the performance of the required maintenance listed in your Operator's Manual. John Deere recommends that the owner retain all receipts covering maintenance on the off-road diesel engine, but John Deere cannot deny warranty solely for the lack of receipts or for the owner's failure to ensure the performance of all scheduled maintenance. However, as the off-road diesel engine owner, you should be aware that John Deere may deny you warranty coverage if your off-road diesel engine or a part has failed due to abuse, neglect, improper maintenance or unapproved modifications.

The off-road diesel engine is designed to operate on diesel fuel as specified in the Fuels, Lubricants and Coolants section in the Operators Manual. Use of any other fuel may result in the engine no longer operating in compliance with applicable emissions requirements.

The owner is responsible for initiating the warranty process, and should present the machine to the nearest authorized John Deere dealer as soon as a problem is suspected. The warranty repairs should be completed by the authorized John Deere dealer as quickly as possible.

Emissions regulations require the customer to bring the unit to an authorized servicing dealer when warranty service is required. As a result, John Deere is NOT liable for travel or mileage on emissions warranty service calls.

Emission_CI_CARB (14Apr20)

DX,EMISSIONS,CARB -19-26AUG20-8/8

RG32759 —UN—19AUG20

Emissions Performance and Tampering

Operation and Maintenance

The engine, including the emissions control system, shall be operated, used, and maintained in accordance with the instructions provided in this manual to maintain the emissions performance of the engine within the requirements applicable to the engine's category/certification.

Tampering

No deliberate tampering with or misuse of the engine emissions control system shall take place; in particular with regard to deactivating or not maintaining an exhaust gas recirculation (EGR) or a DEF dosing system. Tampering with an engine's emissions control system will void the European Union (EU) type approval and applicable emissions-related warranties.

DX,EMISSIONS,PERFORM -19-12JAN18-1/1

Contents

Page	Page
Safety—Safety and Operator Conveniences	
Safety and Operator Convenience Features 1-1-1	
Safety—General Precautions	
Recognize Safety Information 1-2-1	
Follow Safety Instructions 1-2-1	
Prepare for Emergencies 1-2-1	
Operate Only If Qualified 1-2-2	
Wear Protective Equipment 1-2-2	
Protect Against Noise 1-2-2	
Avoid Unauthorized Machine Modifications 1-2-2	
Control Pattern 1-2-3	
Control Pattern Selector—If Equipped 1-2-3	
Inspect Machine 1-2-3	
Stay Clear of Moving Parts 1-2-3	
Avoid High-Pressure Fluids 1-2-3	
Avoid High-Pressure Oils 1-2-4	
Work In Ventilated Area 1-2-4	
Avoid Static Electricity Risk When Refueling 1-2-5	
Prevent Fires, Clean Debris From Machine 1-2-6	
In Case of Machine Fire 1-2-6	
Clean Debris from Machine 1-2-7	
Prevent Battery Explosions 1-2-7	
Handle Chemical Products Safely 1-2-7	
Handle Starting Fluid Safely 1-2-8	
Decommissioning — Proper Recycling and Disposal of Fluids and Components 1-2-8	
Add Cab Guarding for Special Uses 1-2-8	
Safety—Operating Precautions	
Use Steps and Handholds Correctly 1-3-1	
Start Only From Operator's Seat 1-3-1	
Use and Maintain Seat Belt 1-3-1	
Heated and Ventilated Operator's Seat 1-3-2	
Prevent Unintended Machine Movement 1-3-2	
Avoid Work Site Hazards 1-3-3	
Keep Riders Off Machine 1-3-3	
Avoid Backover Accidents 1-3-4	
Avoid Machine Tip Over and Machine Damage 1-3-4	
Avoid Power Lines 1-3-5	
Inspect and Maintain ROPS 1-3-5	
Keep the Operator Protective Structure (OPS) in Place 1-3-5	
Operate Boom With Care 1-3-6	
Operating on Slopes 1-3-6	
Use Special Care When Lifting Objects 1-3-6	
Use Care When Swinging Machine 1-3-6	
Travel Safely 1-3-7	
Prevent Acid Burns 1-3-7	
Add and Operate Attachments Safely 1-3-7	
Saw Chain Hazard 1-3-8	
Safety—Maintenance Precautions	
Park and Prepare for Service Safely 1-4-1	
Service Machines Safely 1-4-1	
Service Cooling System Safely 1-4-2	
Remove Paint Before Welding or Heating 1-4-2	
Make Welding Repairs Safely 1-4-2	
Drive Metal Pins Safely 1-4-3	
Use Proper Lifting Equipment 1-4-3	
Chain Shot Guard Inspection 1-4-3	
Safety—Safety Signs and Other Instructions	
Safety Signs and Other Instructions 1-5-1	
Operation—Operator's Station	
Pedals, Levers, and Panels 2-1-1	
Switch Panel 2-1-1	
Switch Panel Functions 2-1-2	
Rear Panel 2-1-3	
Horn Button 2-1-4	
Power Boost Button 2-1-4	
Pilot Shutoff Lever 2-1-5	
Left Console 2-1-5	
Travel Alarm and Travel Alarm Cancel Switch 2-1-6	
Cab Dome Light Switch 2-1-6	
Horn Switch—Processor Only 2-1-6	
Reversing Fan Switch—If Equipped 2-1-7	
Max Speed Program Switch—If Equipped 2-1-7	
Hydraulic Oil Tank Pressure Vent Switch—If Equipped 2-1-8	
Right Console 2-1-9	
Service and Access Lights Switch—If Equipped 2-1-10	
Service ADVISOR™ Remote (SAR) Switch 2-1-11	
USB Charge Port—If Equipped 2-1-12	
Attachment Combo Switch—If Equipped 2-1-13	
Cab Heater and Air Conditioner 2-1-14	
Selecting Display Between Celsius and Fahrenheit 2-1-15	
Operating the AM/FM Radio 2-1-16	
Satellite Radio—If Equipped 2-1-18	

Continued on next page

Original Instructions. All information, illustrations and specifications in this manual are based on the latest information available at the time of publication. The right is reserved to make changes at any time without notice.

COPYRIGHT © 2023
DEERE & COMPANY
Moline, Illinois
All rights reserved.
A John Deere ILLUSTRATION™ Manual
Previous Editions
Copyright © 2018, 2019, 2020, 2021, 2022

Avoid Static Electricity Risk When Refueling

The removal of sulfur and other compounds in Ultra-Low Sulfur Diesel (ULSD) fuel decreases its conductivity and increases its ability to store a static charge.

Refineries may have treated the fuel with a static dissipating additive. However, there are many factors that can reduce the effectiveness of the additive over time.

Static charges can build up in ULSD fuel while it is flowing through fuel delivery systems. Static electricity discharge when combustible vapors are present could result in a fire or explosion.

Therefore, it is important to ensure that the entire system used to refuel your machine (fuel supply tank, transfer pump, transfer hose, nozzle, and others) is properly grounded and bonded. Consult with your fuel or fuel system supplier to ensure that the delivery system is in compliance with fueling standards for proper grounding and bonding practices.

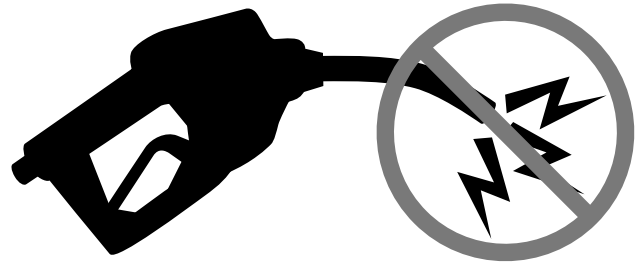

RG22142 —UN—17MAR14

RG21992 —UN—21AUG13

DX,FUEL,STATIC,ELEC -19-12JUL13-1/1

Travel Safely

When working on steep slopes, travel as straight up and down as possible to prevent roll over.

DO NOT PARK ON A HILLSIDE OR AN INCLINE.

Always park the machine on level ground.

Know the location of bystanders before moving the machine.

Always keep the reverse/travel warning alarm in working condition. The alarm warns bystanders when the machine starts to move in reverse.

Use a signal person when moving the machine in congested areas. Coordinate hand signals before starting the machine.

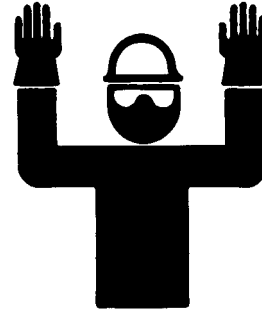

Travel Safely

T6964AD —UN—20DEC88

TX,TRAVEL,SAFE1 -19-08MAY20-1/1

Prevent Acid Burns

Sulfuric acid in battery electrolyte is poisonous. It is strong enough to burn skin, eat holes in clothing, and cause blindness if splashed into eyes.

Avoid the hazard by:

1. Filling batteries in a well-ventilated area.
2. Wearing eye protection and rubber gloves.
3. Avoiding breathing fumes when electrolyte is added.
4. Avoiding spilling or dripping electrolyte.
5. Use proper jump start procedure.

If you spill acid on yourself:

1. Flush your skin with water.
2. Apply baking soda or lime to help neutralize the acid.
3. Flush your eyes with water for 15—30 minutes. Get medical attention immediately.

If acid is swallowed:

1. Do not induce vomiting.
2. Drink large amounts of water or milk, but do not exceed 2 L (2 quarts).
3. Get medical attention immediately.

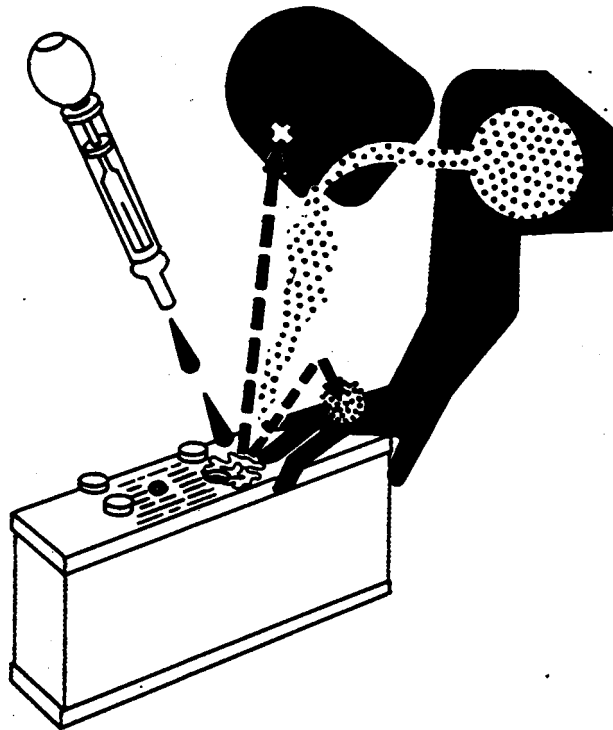

T5203 —UN—23AUG88

DX,POISON -19-21APR93-1/1

Add and Operate Attachments Safely

Always verify compatibility of attachments by contacting your authorized dealer. Adding unapproved attachments could affect machine stability or reliability and could create a hazard for others near the machine.

Ensure that a qualified person is involved in attachment installation. Add guards to machine if operator protection

is required or recommended. Verify that all connections are secure and attachment responds properly to controls.

Carefully read attachment manual and follow all instructions and warnings. In an area free of bystanders and obstructions, carefully operate attachment to learn its characteristics and range of motion.

TX,ATTACH -19-20JAN11-1/1

8. CAUTION, Engine Fan

Engine fan may unexpectedly purge debris from the radiator. Flying debris is a hazard and can cause personal injury.

Stay clear of the machine until the engine has stopped.

This safety label is located inside the cab on the cab door.

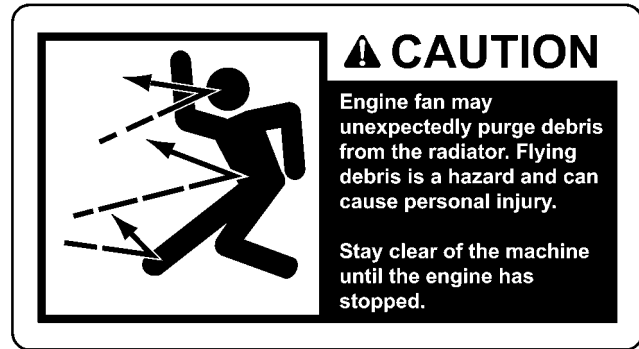

CAUTION, Engine Fan

px7bwb6,1660593393567 -19-29NOV22-9/58

TX1153338 —19—07AUG14

9. CAUTION, Cab Riser

- To avoid injury, never operate this machine unless the cab riser hold down bolts have been properly installed.
- Check bolts regularly and retorque when necessary.

This safety label is located inside the cab on the cab door.



CAUTION, Cab Riser

px7bwb6,1660593393567 -19-29NOV22-10/58

TX1211371 —19—23FEB16

10. DANGER, Electric Lines

Serious injury or death can result from contact with electric lines.

Never move any part of unit or load closer to electric line than 3 M [10 FT.] plus twice the line insulator length.

This safety label is located inside the cab on the right side window.

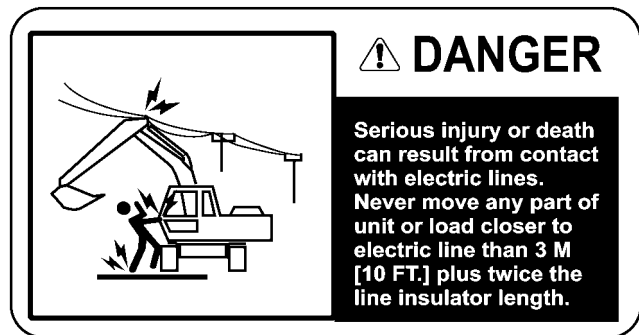

DANGER, Electric Lines

Continued on next page

px7bwb6,1660593393567 -19-29NOV22-11/58

TX1104374 —19—19DEC12

1. **IMPORTANT, Polycarbonate Windows**

THIS MACHINE HAS POLYCARBONATE WINDOWS
- Common cleaning agents may be incompatible with polycarbonate

Clean with John Deere Polycarbonate Cleaner

DO NOT use glass cleaners on polycarbonate

See Operator's Manual for additional care instructions

This label is located inside the cab on the front window.

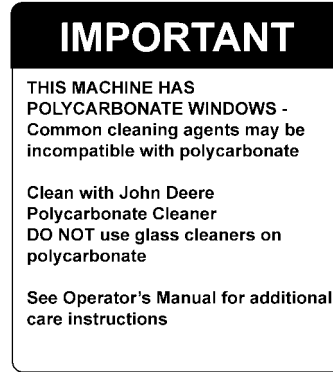

IMPORTANT, Polycarbonate Windows

px7bwb6,1660593393567 -19-29NOV22-32/58

TX1238760 —19—11MAY17

2. **CAUTION, Attachment**

Attachment can hit cab.

This safety label is located inside the cab on the front window.



CAUTION, Attachment

px7bwb6,1660593393567 -19-29NOV22-33/58

TX1211401 —19—24FEB16

3. **IMPORTANT, Operator Protective Structure (OPS)**

KEEP THE OPERATOR PROTECTIVE STRUCTURE (OPS) IN PLACE

Keep doors, screens, windows, windshield, etc. in place to minimize hazards from whipping or intruding objects. Replace damaged parts immediately.

This safety label is located inside the cab on the left roll-over protective structure (ROPS) post.

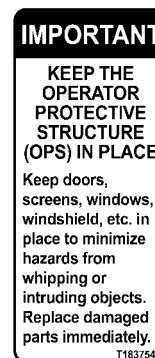

IMPORTANT, Operator Protective Structure (OPS)

Continued on next page

px7bwb6,1660593393567 -19-29NOV22-34/58

TX1130522 —19—08FEB13

27. CAUTION, Sharp Objects—If Equipped

Prevent possible injury from sharp objects. Always mount tools with tool head pointed downward.

This safety label is located on the right side of the machine behind the log deflector.

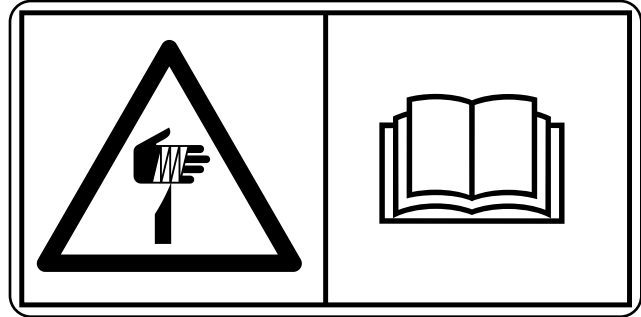

CAUTION, Sharp Objects (if equipped)

px7bwb6,1660593393567 -19-29NOV22-58/58

TX1261067—UN—18JUL18

Service and Access Lights Switch—If Equipped



Service and Access Lights Switches (console switches)

TX1213307—UN—28MAR16

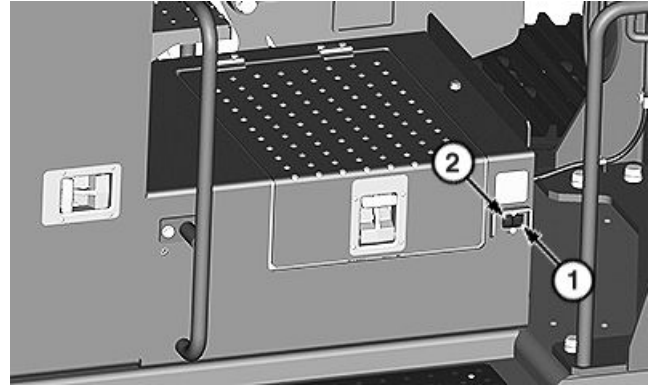

Service and Access Lights Switches (step switches)

TX1216363—UN—15JUN16

There are two sets of service and access lights switches (1 and 2). Both sets of switches control the same lights. One set of switches is located in the cab on the right console (early production) or left console (late production) and the other set of switches is located on the bottom of the steps on the right side of the machine.

Press service lights switch (1) to turn on all compartment lights.

Compartment light locations:

- Engine compartment
- Right service compartments
- Left service compartments
- Cab riser compartment (if equipped)

Press the access light switch (2) to turn on the access light (3) on the rear side of the cab.

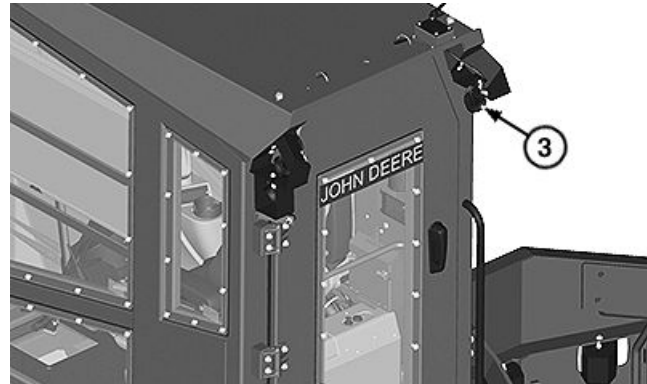

Access Light—Rear Entry Cab

TX1216334—UN—25MAY16



Access Light—Side Entry Cab

TX1216335—UN—25MAY16

- 1— Service Lights Switch
- 2— Access Light Switch

- 3— Access Light

KR46761,00011C5 -19-27JUL18-1/1

Hydraulic Oil Level Alarm—If Equipped

IMPORTANT: Avoid possible machine damage to hydraulic pump. Immediately park and turn off machine if hydraulic oil level alarm (1) is activated.

When hydraulic oil tank level is critically low, the hydraulic oil level alarm (1) is activated. The indicator illuminates as an audible warning advises the operator to park and turn off machine within 5 seconds to avoid hydraulic pump damage.

1—Hydraulic Oil Level Alarm

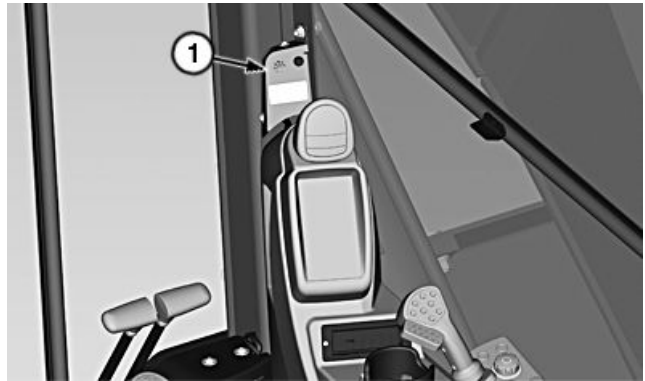

Hydraulic Oil Level Alarm (early production)

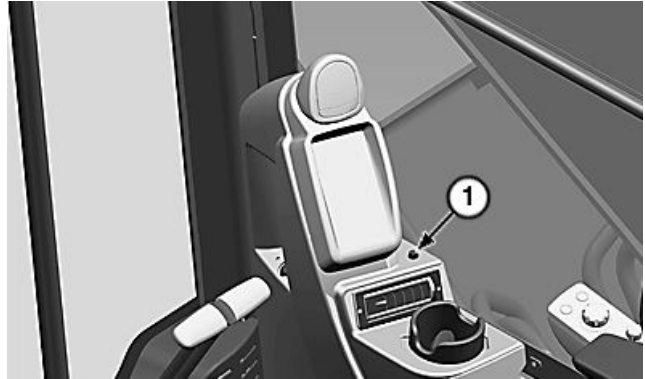

Hydraulic Oil Level Alarm (late production)

TX1260999A —UN—17JUL18

TX1302520A —UN—09SEP20

TD48962,00000E6 -19-14SEP20-1/1

Operation—Monitor Operation

Monitor



TX1219418

Monitor

- | | |
|-----------------------------|-------------------------------|
| 1— Work Mode Indicator | 11— Fuel Mark |
| 2— Auxiliary Indicator | 12— Sub Meter |
| 3— Power Mode Indicator | 13— Radio Display |
| 4— Auxiliary Indicator | 14— Air Conditioner Display |
| 5— Auxiliary Indicator | 15— Coolant Temperature Mark |
| 6— Hour Meter and Clock | 16— Coolant Temperature Gauge |
| 7— Engine Preheat Indicator | 17— Travel Mode Indicator |
| 8— Seat Belt Indicator | 18— Auto-Idle Indicator |
| 9— Not Used | 19— Auto Shutdown Indicator |
| 10— Fuel Gauge | 20— Alarm Indicators |

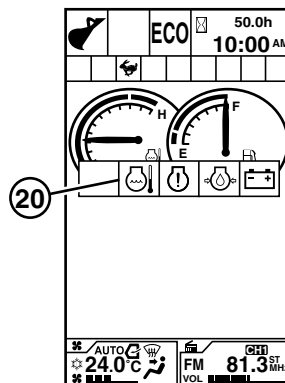

Alarm Indicators

TX1219418—UN—19JUL16

TX1219419—UN—19JUL16

KR46761,00012C6 -19-01MAR17-1/1

□ **A/C**

NOTE: Blower speed switch on switch panel needs to be ON in order to operate the ON/OFF function of the air conditioner in the monitor menu.

Rotate monitor dial to highlight A/C. Press monitor dial to turn ON the air conditioner. The color of the preceding square will turn green and an air conditioner icon (7) will appear in the air conditioner display in the lower left corner of the monitor. Press monitor dial again to turn OFF the air conditioner. The color of the preceding square will be gray and air conditioner icon will disappear.

If an exclamation mark appears on the monitor, communication between the air conditioner and the monitor is abnormal. See an authorized John Deere dealer.

Press back button (3) to return to previous screen.

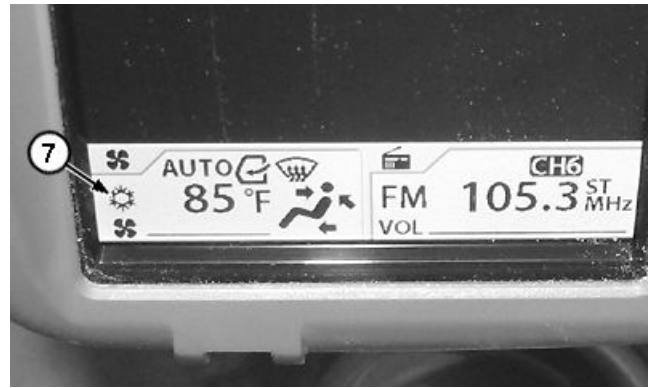

Air Conditioner Icon

7— Air Conditioner Icon

Press home button (4) to return to default screen.

KR46761.00014A7 -19-30JAN17-2/2

Main Menu—Information Menu—Operation

The **Operation** menu provides fuel consumption and operating hours of the breaker, front attachment, tracks, and overall machine hours.

At Information Menu, rotate monitor dial to highlight Operation. Press monitor dial to display Operation menu.

NOTE: Total fuel consumption and fuel consumption rate depend on the operating environment and the operation method of machine.

Operation menu items include:

• **Fuel Consumption**

Rotate monitor dial to highlight Fuel Consumption. Press monitor dial to display Fuel Consumption information:

- **Machine Operation Hours** **XX h**
- **Fuel Consumption** **XX L**
- **Average Fuel Consumption Rate**....**XX.X L/h**

Press monitor dial to return to the previous menu. To reset fuel consumption data, rotate monitor dial to highlight CLEAR in the bottom right corner of screen and press monitor dial.

• **Breaker Operation**

Rotate monitor dial to highlight Breaker Operation. Press monitor dial to display Breaker Operation information:

- **Operating Time****XXXXXX.X h**
- **Machine Operation Hours****XXXX.X h**
- **Operation Ratio**.....**XXX.X %**

Press monitor dial to return to the previous menu. To reset breaker operating data, rotate monitor dial to highlight CLEAR in the bottom right corner of screen and press monitor dial.

• **Attachment Operation**

Rotate monitor dial to highlight Attachment Operation. Press monitor dial to display Attachment Operation information:

- **Operating Time****XXXX.X h**

Press monitor dial to return to the previous menu. To reset attachment operating hours, rotate monitor dial to highlight CLEAR in the bottom right corner of screen and press monitor dial.

• **Travel Operation**

Rotate monitor dial to highlight Travel Operation. Press monitor dial to display Travel Operation information:

- **Operating Time****XXXX.X h**

Press monitor dial to return to the previous menu. To reset travel operating hours, rotate monitor dial to highlight CLEAR in the bottom right corner of screen and press monitor dial.

• **Actual Operation**

NOTE: The actual operation time includes the front attachment operation and the travel operation hours.

Rotate monitor dial to highlight Actual Operation. Press monitor dial to display Actual Operation information:

- **Operating Time****XXXX.X h**

Press monitor dial to return to the previous menu. To reset actual operating hours, rotate monitor dial to highlight CLEAR in the bottom right corner of screen and press monitor dial.

Press back button to return to previous screen.

Press home button to return to default screen.

Control Levers

IMPORTANT: Prevent unintended machine movement. Some control lever functions can be reassigned to suit operator preference. Verify machine functions before operating. For more information, see an authorized John Deere dealer.

Forestry Excavator

- | | |
|----------------------|----------------|
| 1—Horn Button | 6—Swing Right |
| 2—Power Boost Button | 7—Boom Lower |
| 3—Arm Out | 8—Boom Raise |
| 4—Arm In | 9—Bucket Curl |
| 5—Swing Left | 10—Bucket Dump |

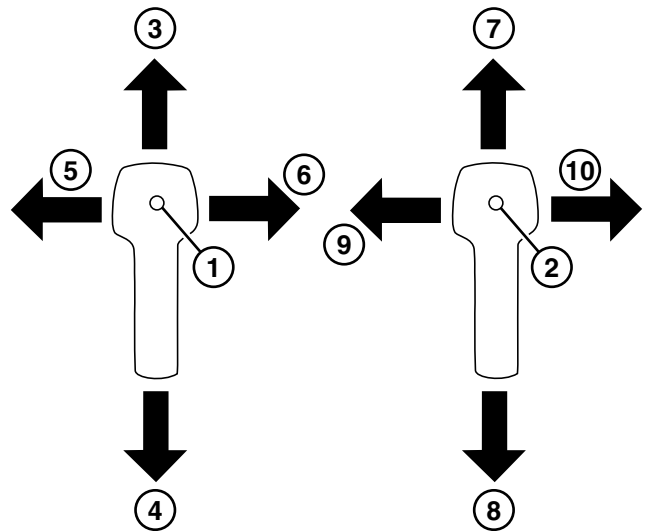

Control Levers

KR46761,00011DC -19-20JUN19-1/4

TX1213079—UN—31MAR16

Forestry Excavator With Thumb—If Equipped

- | | |
|----------------------|----------------|
| 1—Not Used | 8—Swing Left |
| 2—Horn Button | 9—Swing Right |
| 3—Thumb Open | 10—Boom Lower |
| 4—Thumb Close | 11—Boom Raise |
| 5—Power Boost Button | 12—Bucket Curl |
| 6—Arm Out | 13—Bucket Dump |
| 7—Arm In | |

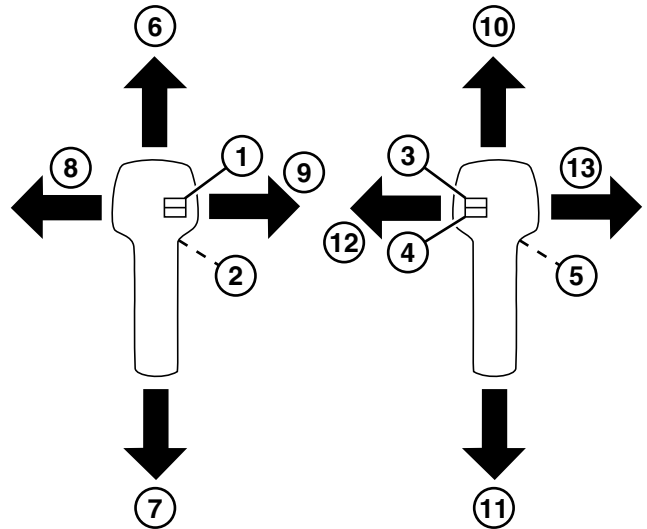

Control Levers

Continued on next page

KR46761,00011DC -19-20JUN19-2/4

TX1213080—UN—30MAR16

Securing the Machine to Transport Equipment

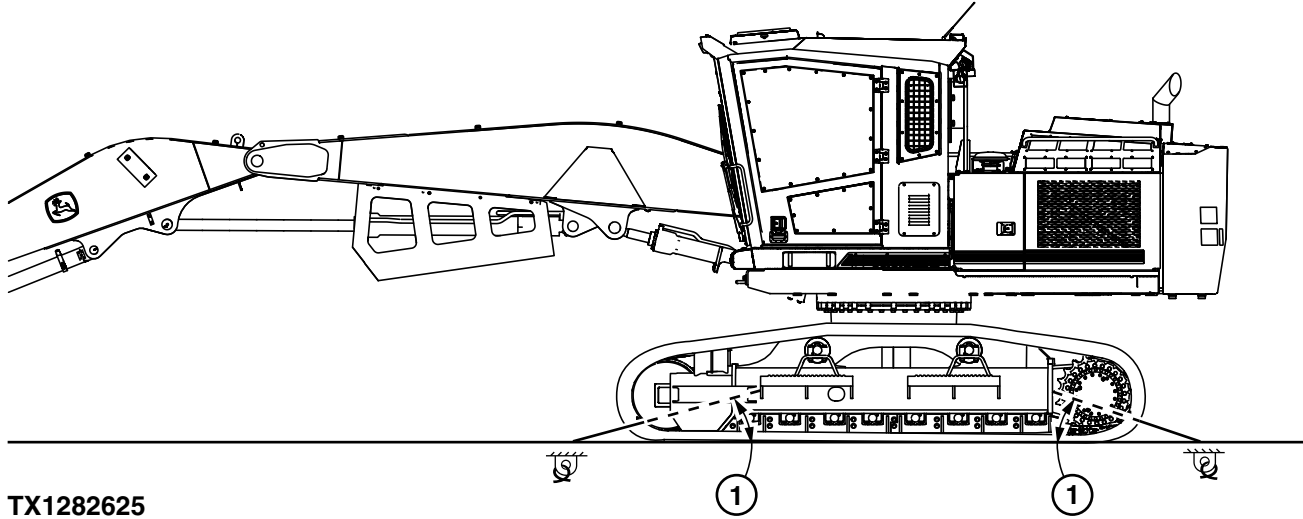

TX1282625

Machine (side entry cab, left side shown)

- 1—Vertical Tiedown Angle (4 used)
2—Side Tiedown Angle (4 used)

TD48962,00001CD -19-25OCT19-3/4

TX1282625—UN—01AUG19

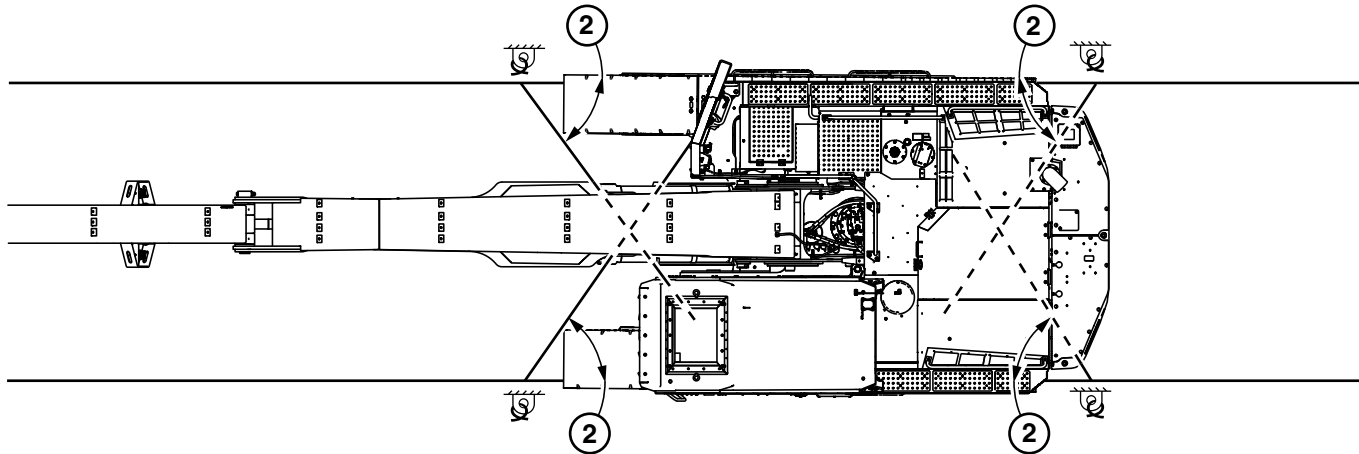

TX1282626

Machine (side entry cab, top of machine shown)

- 1—Vertical Tiedown Angle (4 used)
2—Side Tiedown Angle (4 used)

IMPORTANT: Avoid machine damage. Fasten chains or cables to machine frame. Do not place chains or cables over or against hydraulic lines or hoses.

1. Fasten machine to trailer using chains or cables with appropriate load binder at the following points:
 - Front frame tiedown point (2 used)

- Rear frame tiedown point (2 used)

Ensure vertical tiedown angles (1) and side tiedown angles (2) have angles between 15—60°.

2. Fasten all equipment to trailer using chains or cables with appropriate load binder.

TD48962,00001CD -19-25OCT19-4/4

TX1282626—UN—01AUG19

Diesel Engine Break-In™ Oil— Non-Emissions Certified and Certified Tier 1, Tier 2, Tier 3, Stage I, Stage II, and Stage III

New engines are filled at the factory with either John Deere Break-In™ or Break-In Plus™ Engine Oil. During the break-in period, add John Deere Break-In or Break-In Plus Engine Oil, respectively, as needed to maintain the specified oil level.

Operate the engine under various conditions, particularly heavy loads with minimal idling, to help seat engine components properly.

Change the oil and filter at 250 hours maximum for Break-In Oil or 500 hours maximum for Break-In Plus Oil during the initial operation of a new or rebuilt engine.

After engine overhaul, fill the engine with either John Deere Break-In or Break-In Plus Engine Oil.

If John Deere Break-In or Break-In Plus Engine Oil is not available, use a 10W-30 diesel engine oil meeting one of the following during the first 250 hours of operation:

- API Service Classification CE
- API Service Classification CD
- API Service Classification CC
- ACEA Oil Sequence E2
- ACEA Oil Sequence E1

IMPORTANT: Do not use Plus-50™ II, Plus-50, or engine oils meeting any of the following for the initial break-in of a new or rebuilt engine:

*Break-In is a trademark of Deere & Company
Break-In Plus is a trademark of Deere & Company
Plus-50 is a trademark of Deere & Company*

API CK-4	ACEA E9
API CJ-4	ACEA E7
API CI-4 PLUS	ACEA E6
API CI-4	ACEA E5
API CH-4	ACEA E4
API CG-4	ACEA E3
API CF-4	
API CF-2	
API CF	

These oils will not allow the engine to break in properly.

John Deere Break-In Plus Engine Oil can be used for all John Deere diesel engines at all emission certification levels.

After the break-in period, use John Deere Plus-50 II, John Deere Plus-50, or other diesel engine oil as recommended in this manual.

TX,ENOIL4 -19-12AUG20-1/1

Water Quality for Mixing with Coolant Concentrate

Engine coolants are a combination of three chemical components: ethylene glycol (EG) or propylene glycol (PG) antifreeze, inhibiting coolant additives, and quality water.

Water quality is important to the performance of the cooling system. Deionized or demineralized water is recommended for mixing with ethylene glycol and propylene glycol base engine coolant concentrate.

All water used in the cooling system should meet the following minimum specifications for quality:

Chlorides	<40 mg/L
Sulfates	<100 mg/L
Total solids	<340 mg/L
Total dissolved l hardness	<170 mg/L
pH	5.5—9.0

IMPORTANT: Do not use bottled drinking water because it often contains higher concentrations of total dissolved solids.

Freeze Protection

The relative concentrations of glycol and water in the engine coolant determine its freeze protection limit.

Ethylene Glycol	Freeze Protection Limit
40%	-24°C (-12°F)
50%	-37°C (-34°F)
60%	-52°C (-62°F)
Propylene Glycol	Freeze Protection Limit
40%	-21°C (-6°F)
50%	-33°C (-27°F)
60%	-49°C (-56°F)

DO NOT use a coolant-water mixture greater than 60% ethylene glycol or 60% propylene glycol.

DX,COOL19 -19-13JAN18-1/1

Operating in Warm Temperature Climates

John Deere engines are designed to operate using recommended engine coolants.

Always use a recommended engine coolant, even when operating in geographical areas where freeze protection is not required.

IMPORTANT: Water may be used as coolant in emergency situations only.

Foaming, hot surface aluminum and iron corrosion, scaling, and cavitation occur when water is used as the coolant, even when coolant conditioners are added.

Drain cooling system and refill with recommended engine coolant as soon as possible.

DX,COOL6 -19-17FEB20-1/1

CLICK HERE TO **DOWNLOAD** THE COMPLETE MANUAL

- Thank you very much for reading the preview of the manual.
- You can download the complete manual from: www.heydownloads.com by clicking the link below



- Please note: If there is no response to CLICKING the link, please download this PDF first and then click on it.

CLICK HERE TO **DOWNLOAD** THE COMPLETE MANUAL

Required Parts

REQUIRED PARTS							
Ensure machine performance and availability; use only genuine John Deere parts. Verify that part numbers are current and that any associated parts are also on hand, i.e., filter O-rings.							
Description	Every 250 Hours	Every 500 Hours	Every 1000 Hours	Every 2000 Hours	Every 4000 Hours	Every 5000 Hours	Every 6000 Hours
Engine Oil Filter		1	1	1	1	1	1
Primary Fuel Filter Element		1	1	1	1	1	1
Final Fuel Filter Element		1	1	1	1	1	1
Auxiliary Fuel Filter Element (if equipped)		1	1	1	1	1	1
Hydraulic Tank Oil Filter Element			1	1	1	1	1
Pilot Oil Filter Element			1	1	1	1	1
Primary Air Filter Element			1	1	1	1	1
Secondary Air Filter Element			1	1	1	1	1
Dust Unloader Valve			1	1	1	1	1
Fuel Tank Breather			1	1	1	1	1
Engine Rocker Arm Cover Gasket				1	1		1
Engine Crankshaft Damper					1		
Hydraulic Tank Cap Breather Element						1	
Cab Fresh Air Filter	As Required						
Cab Recirculating Air Filter	As Required						
Serpentine Belt	As Required						
Air Conditioner V-Belt	As Required						
High-Pressure Supply Filter (if equipped)	As Required						
Case Drain Filter (if equipped)	As Required						
John Deere Plus-50™ II Engine Oil ³		19.5 L (5.2 gal)	20.5 L (5.4 gal)	20.5 L (5.4 gal)	20.5 L (5.4 gal)	20.5 L (5.4 gal)	20.5 L (5.4 gal)
API GL-5 Swing Gear Case Oil ³			11.8 L (3.1 gal)	11.8 L (3.1 gal)	11.8 L (3.1 gal)	11.8 L (3.1 gal)	11.8 L (3.1 gal)
API GL-5 Travel Gear Case Oil ³				17.0 L (4.4 gal)	17.0 L (4.4 gal)		17.0 L (4.4 gal)
John Deere Hydraul™ XR Hydraulic Oil ^{1,3}				147.6 L (39.0 gal)	147.6 L (39.0 gal)		147.6 L (39.0 gal)
John Deere Zinc-Free Hydraulic Oil 46 ^{2,3}						147.6 L (39.0 gal)	
John Deere Hydraul™ XR Cab Tilt Oil ³ —Rear Entry Cab Only						3.3 L (3.4 qt)	
John Deere Cool-Gard™ II Pre-Mix							23.0 L (6.1 gal)
Fluid Analysis Kits⁴							
Diesel Engine Oil	1	1	1	1	1	1	1
Hydraulic Oil		1	1	1	1	1	1
Travel Gear Case Oil		2	2	2	2	2	2
Swing Gear Case Oil		1	1	1	1	1	1
Pump Drive Gear Case Oil		1	1	1	1	1	1
Cab Tilt Oil—Rear Entry Cab Only		1	1	1	1	1	1

Continued on next page

JL41294,000036C -19-13JUL22-1/2

Clean Auxiliary Hydraulic Cooler Screen—If Equipped

⚠ CAUTION: Clear area of bystanders and wear personal protection equipment, including eye protection. Reduce compressed air to less than 196 kPa (1.96 bar) (28.4 psi) when using for cleaning purposes.

1. Remove cap screws (1) and lift auxiliary hydraulic cooler screen (2) to remove.
2. Attach an air wand to an air compressor and blow out dirt and debris from auxiliary hydraulic cooler screen.
3. Install auxiliary hydraulic cooler screen and cap screws.

1— Cap Screw (4 used)

2— Auxiliary Hydraulic Cooler Screen

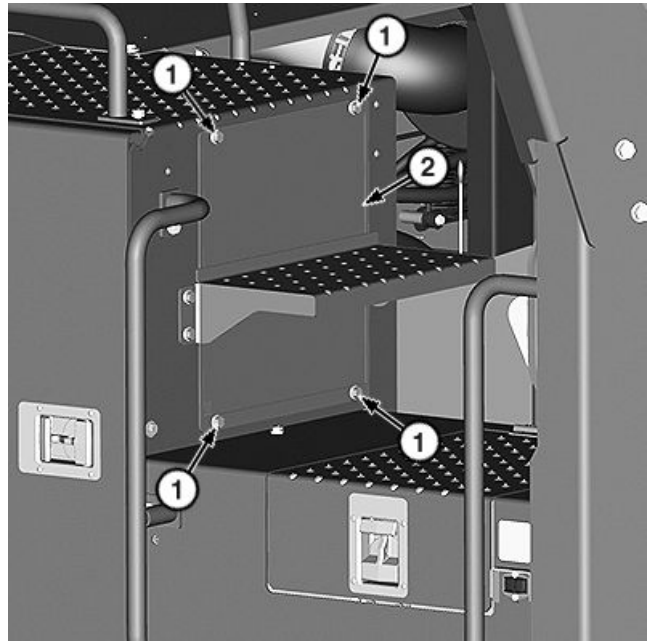

TX1217630 —UN—15JUN16

Auxiliary Hydraulic Cooler Screen

KR46761,000122E -19-26JUL16-1/1

Lubricate Door Hinges

Lubricate all door hinge grease fittings until grease escapes at joints. See Track Adjuster, Working Tool Pivot, Swing Bearing, and Swing Bearing Gear Grease. (Section 3-1.)

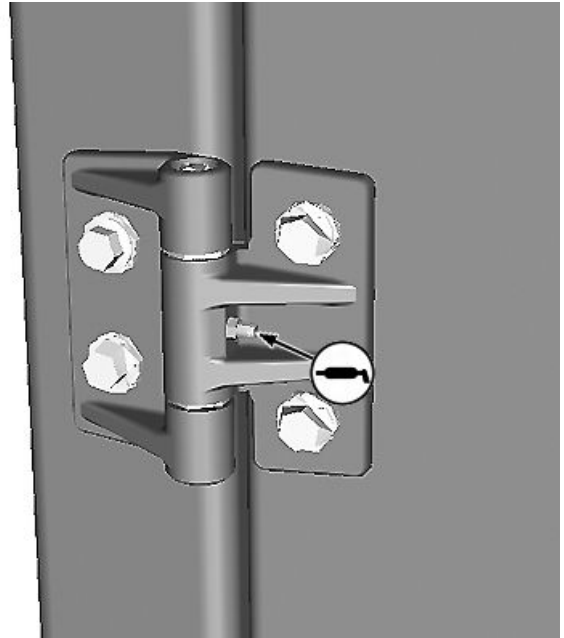

TX1216139 —UN—23MAY16

Door Hinge Grease Fitting

KR46761,0001168 -19-23MAY16-1/1

Lubricate Working Tool Pivots—If Equipped

NOTE: See attachment manufacturer's manual for recommended service.

Lubricate working tool pivots (4 points) until grease escapes from joints. See Track Adjuster, Working Tool Pivot, Swing Bearing, and Swing Bearing Gear Grease. (Section 3-1.)

Lubricate every 4 hours for first 20 hours of operation, then every 10 hours thereafter.

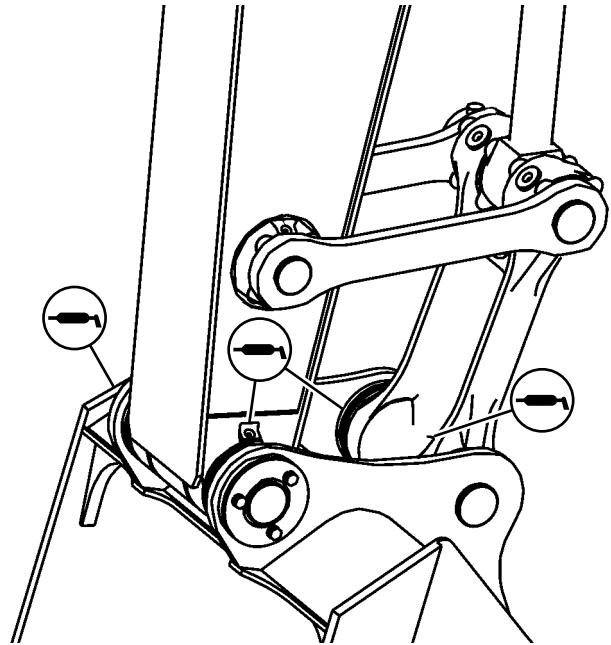

Forestry Excavator (four points)

TX1211165—UN—18FEB16

KR46761.0001234 -19-30JUN16-1/1

Replace Hydraulic Tank Oil Filter

1. Park and position machine with arm cylinder fully retracted and bucket cylinder (if equipped) fully extended.

IMPORTANT: Turbocharger can be damaged if procedure to shut down engine is not done properly.

2. Run engine at slow idle speed without load for 5 minutes.
3. Stop engine.
4. Insert 4 mm hex wrench (2) into hole (3) and turn counterclockwise to release locking pin.

CAUTION: Avoid personal injury from high-pressure fluid. High-pressure release of oil from pressurized system can cause serious burns or penetrating injury. Relieve pressure by slowly turning hydraulic tank cap (1) counterclockwise a few degrees.

To prevent possible burn injury from hot hydraulic oil, wait for hydraulic oil to cool before starting work.

5. Slowly turn hydraulic tank cap (1) counterclockwise a few degrees to relieve pressure.
6. Hold down hydraulic oil filter cover (6) against light spring load when removing the last two cap screws (7).

- | | |
|-----------------------|-------------------------------|
| 1— Hydraulic Tank Cap | 5— Aligning Mark (2 used) |
| 2— Hex Wrench | 6— Hydraulic Oil Filter Cover |
| 3— Hole | 7— Cap Screw (6 used) |
| 4— Case Assembly | |



Pressurized Fluids

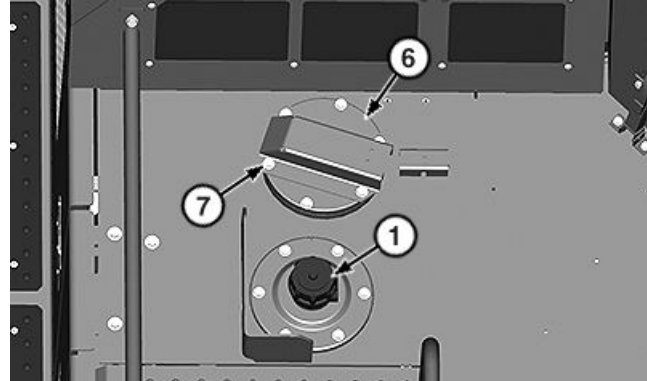

Hydraulic Tank

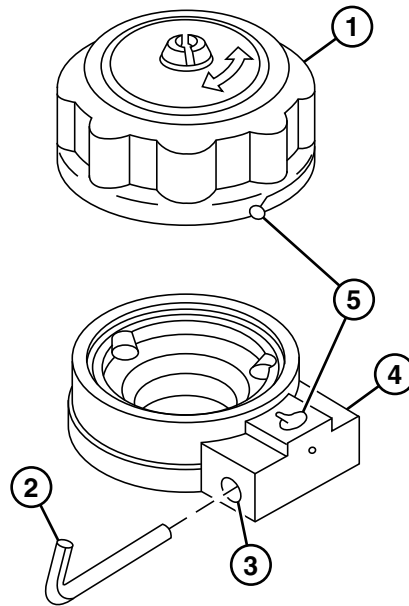

Hydraulic Tank Cap

Continued on next page

KR46761,0001253 -19-12JUL16-1/2

TS281 —UN—15APR13

TX1217874 —UN—21JUN16

TX1217692 —UN—22JUN16

Maintenance—Every 2000 Hours

Drain and Refill Hydraulic Tank Oil and Clean Suction Screen

Change original factory fill hydraulic oil after first 2000 hours. Change every 2000 hours thereafter if using John Deere Hydrau™ XR zinc-based hydraulic oil. If using alternative oils, see Hydraulic Oil. (Section 3-1.)

Perform this service at the 2000-hour interval when operating in normal conditions. When operating with an attachment, drain and refill as necessary.

IMPORTANT: Prevent damage to hydraulic system components. Do NOT run engine without oil in the tank.

This machine is factory filled with either John Deere Zinc-Free Hydraulic Oil 46 extended life hydraulic oil or John Deere Hydrau™ XR zinc-based hydraulic oil. Avoid servicing this machine with products that do not meet these specifications. If oils have been mixed or if alternate service oils are desired, the complete hydraulic system needs to be completely flushed by an authorized dealer.

Avoid mixing different brands or types of oils. Oil manufacturers engineer their oils to meet certain specifications and performance requirements. Mixing different oil types can degrade lubricant and machine performance.

1. Park machine on level surface with upperstructure rotated 90° for easier access. Position machine with arm cylinder fully retracted and bucket cylinder (if equipped) fully extended.

IMPORTANT: Turbocharger can be damaged if procedure to shut down engine is not done properly.

2. Run engine at low idle speed without load for 5 minutes.
3. Stop engine.
4. Insert 4 mm hex wrench (2) into hole (3) and turn counterclockwise to release locking pin.

CAUTION: Avoid personal injury from high-pressure fluid. High-pressure release of oil from pressurized system can cause serious burns or penetrating injury. Relieve pressure by slowly turning hydraulic tank cap (1) counterclockwise a few degrees.

To prevent possible burn injury from hot hydraulic oil, wait for hydraulic oil to cool before starting work.

5. Slowly turn hydraulic tank cap (1) counterclockwise a few degrees to relieve pressure. Remove cap.
6. Remove cap screws (6).

Hydrau is a trademark of Deere & Company



Pressurized Fluids

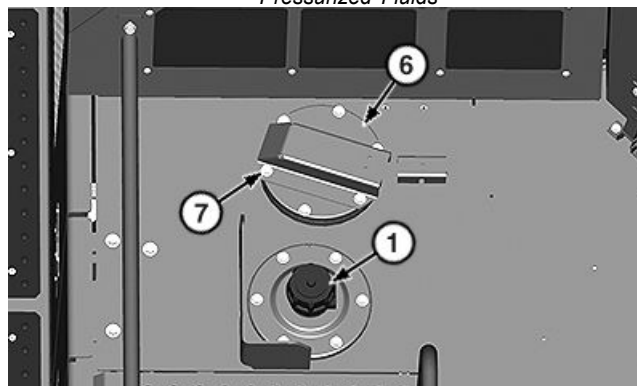

Hydraulic Tank

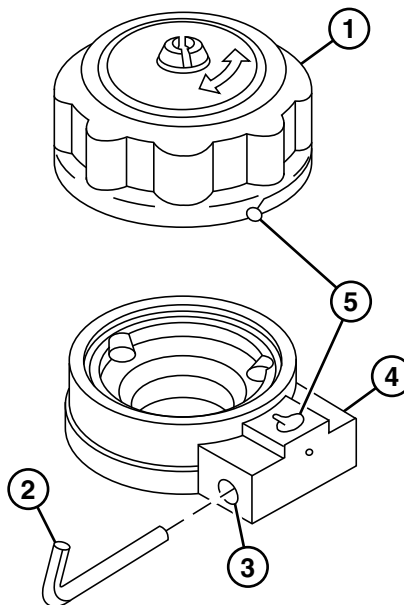

Hydraulic Tank Cap

- | | |
|-----------------------|---------------------------|
| 1— Hydraulic Tank Cap | 5— Aligning Mark (2 used) |
| 2— Hex Wrench | 6— Cap Screw (6 used) |
| 3— Hole | 7— Hydraulic Tank Cover |
| 4— Case Assembly | |

7. Remove hydraulic tank cover (7).

Continued on next page

KR46761.0001263 -19-23AUG22-1/2

Cooling System Fill and Deaeration Procedure



Pressurized Fluids

CAUTION: Prevent possible injury from hot, spraying fluids. Shut off engine. Remove filler cap only when cool enough to touch with bare hands. Slowly loosen cap to relieve pressure before removing completely.

IMPORTANT: Avoid mixing different brands or types of coolant. Coolant manufacturers engineer their coolants to meet certain specifications and performance requirements. Mixing different coolant types can degrade coolant and machine performance.

Use only permanent-type, low silicate, ethylene glycol antifreeze in coolant solution. Other types of antifreeze may damage cylinder seals.

John Deere COOL-GARD™ II Pre-Mix coolant is recommended when adding new coolant to cooling system.

Follow directions on container for correct mixture ratio.

FREEZING TEMPERATURES: Fill with permanent-type, low silicate, ethylene glycol antifreeze (without stop-leak additive) and clean soft water.

Fill

Remove surge tank cap (1) to relieve pressure. Fill surge tank to above the full hot mark. See Diesel Engine Coolant (engine with wet sleeve cylinder liners). (Section 3-1.) Install surge tank cap.

Deaeration

The cooling system requires several warm-up and cool down cycles to deaerate. It will NOT deaerate during normal operation. Only during warm-up and cool down cycles will the system deaerate.

1. Start engine. Run engine until coolant reaches a warm temperature.

COOL-GARD is a trademark of Deere & Company

TS281 —UN—15APR13

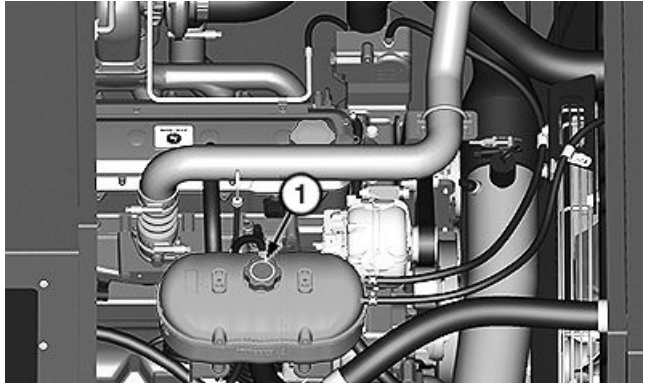

Surge Tank (engine 6068HT130)

TX1220418 —UN—03AUG16

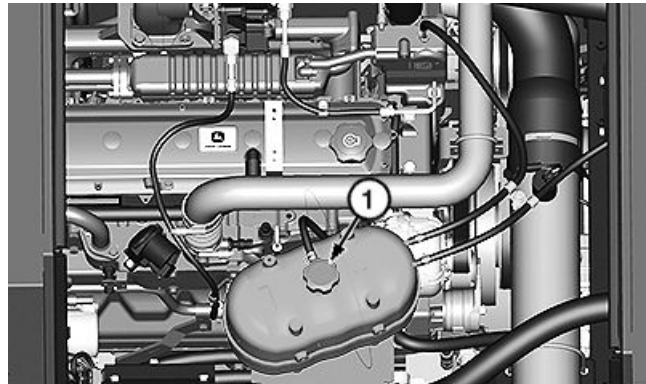

Surge Tank (engine 6068HT122)

TX1220629 —UN—04AUG16

1— Surge Tank Cap

2. Stop engine. Allow coolant to cool.
3. Check coolant level at surge tank. See Check Engine Coolant Level. (Section 3-4.)
4. Repeat steps 1—3 until surge tank coolant level is repeatedly at the same level (stabilized).

NOTE: Coolant level **MUST BE** repeatedly checked after all drain and refill procedures to ensure that all air is out of the system, which allows the coolant level to stabilize. Coolant level should only be checked when the engine is cold.

5. If necessary, fill surge tank to above the MIN COLD mark.

Specification

Cooling System—Capacity.....	23.0 L
	6.1 gal

KR46761,00012F0 -19-05AUG16-1/1

Using Booster Batteries—24-Volt System

Before boost starting, machine must be properly shut down to prevent unexpected machine movement when engine starts.

CAUTION: An explosive gas is produced while batteries are in use or being charged. Keep flames or sparks away from the battery area. Make sure the batteries are charged in a well-ventilated area.

IMPORTANT: The machine electrical system is a 24-volt negative (-) ground. Connect two 12-volt booster batteries together as shown for 24 volts.

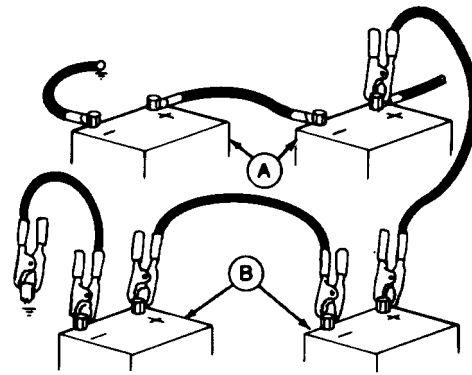

Booster Batteries, 2-Battery Application

1. Connect one end of the positive (+) cable to the positive (+) terminal of the machine batteries (A) and the other end to the positive (+) terminal of the booster batteries (B).
2. Connect one end of the negative (-) cable to the negative (-) terminal of the booster batteries. Connect the other end of the negative (-) cable to the machine frame as far away from the machine batteries as possible.
3. Start engine.

A—Machine Battery (2 used) B—Booster Battery (2 used)

4. Immediately after starting engine, disconnect the end of the negative (-) cable from the machine frame. Then disconnect the other end of the negative (-) cable from the negative (-) terminal of the booster batteries.
5. Disconnect positive (+) cable from booster batteries and machine batteries.

OUT4001,0000238 -19-09MAR17-1/1

T7233JN —UN—21MAY90

Replacing Batteries

CAUTION: Avoid personal injury from battery acid. Always wear protective equipment. Sulfuric acid in battery electrolyte is poisonous. Sulfuric acid is strong enough to burn skin, eat holes in clothing, and cause blindness if splashed into eyes.

NOTE: Reserve capacity is the time in minutes it takes a fully charged battery at 26.6°C (80°F) to drop below 10 volts.

Turn battery disconnect switch to the OFF position. See Battery Disconnect Switch. (Section 2-3.)

Open left rear service door to access batteries (1).

This machine has two 12-volt batteries with negative (-) ground connected in series to provide 24 volts.

Only use batteries which meet the following specifications:

	Specification
Battery—Cold Cranking Amps (CCA) at -18°C (0°F) per Battery.....	1000 CCA
Battery—Minutes Reserve Capacity at 25 Amps per Battery.....	440 min

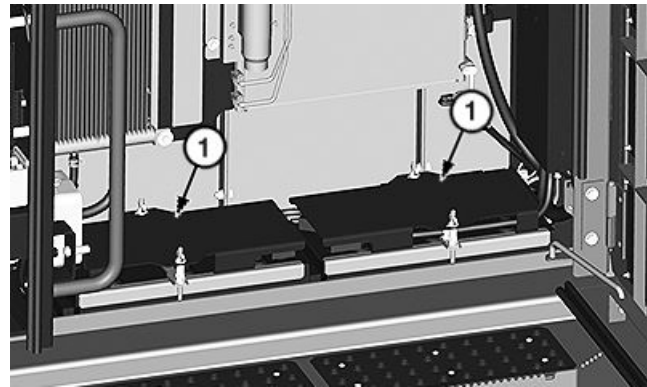

Batteries

1— Battery (2 used)

If one battery in a 24-volt system has malfunctioned but the other is still good, replace the malfunctioned battery with one of the same type. For example, replace a malfunctioned maintenance-free battery with a new maintenance-free battery. Different types of batteries may have different rates of charge. This difference could overload one of the batteries and cause it to malfunction.

KR46761,0001283 -19-06JUL16-1/1

TX1218740 —UN—06JUL16

Check Track Shoe Hardware

Check track shoes periodically for loose or missing cap screws and nuts. For shoes with missing or loose cap screws and nuts, remove shoes and clean the mating surface of shoes and links before tightening cap screws and nuts. Replace cap screws when they have been stretched to yield previously.

Operating a machine with loose shoes can cause the cap screws and holes in the shoes and links to wear, making it difficult to keep the shoes tight. Loose shoes can also cause hardware malfunction and loss of shoes.

1. Clean the mating surface of shoe and links. Install shoes.
2. Apply a light coating of oil to cap screw threads before installing.
3. Install nuts with the rounded corners against milled surface of link and chamfered side away from link.

Check that nuts are square with the milled surface of link and there is full contact between nut and milled surface. As necessary, hold the nut so it does not turn.

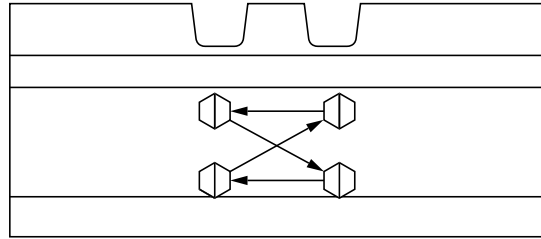

Cap Screw Tightening Sequence

4. Starting at any cap screw, tighten all cap screws in sequence shown to the torque specification, then tighten an additional 1/2 turn (180°).

TX,TRACKSHOE -19-10MAR22-1/1

TX1255661 —UN—19APR18

Hardware Torque Specifications

Check cap screws and nuts to be sure they are tight. If hardware is loose, tighten to torque shown on the following charts unless a special torque is specified.

TX,90,FF1225 -19-15MAR93-1/1

Rear Camera Check
(if equipped)



TX1113092A —UN—27APR12

Default Screen

5— Default Screen

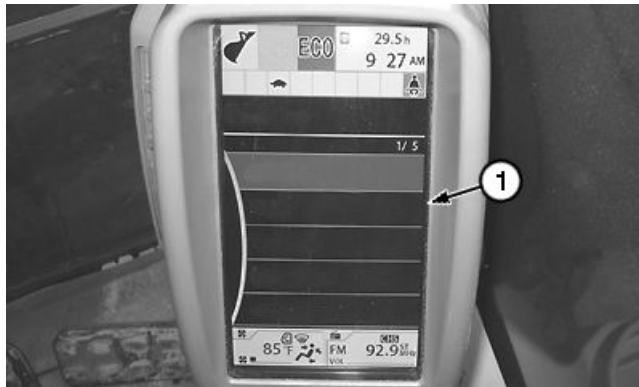

TX1113093A —UN—27APR12

Main Menu Screen

1— Main Menu Screen

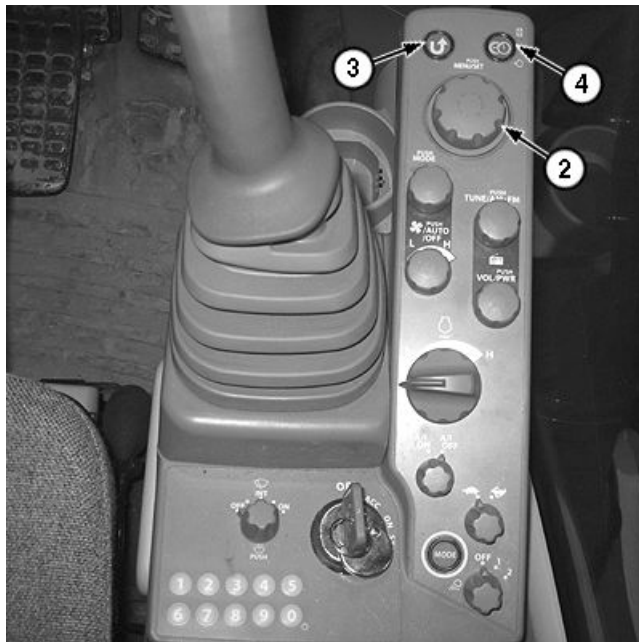

TX1086272A —UN—27DEC10

Switch Panel

- 2— Monitor Dial
- 3— Back Button
- 4— Home Button

Continued on next page

KR46761,000131D -19-15SEP22-12/51

Engine Speed Dial Check

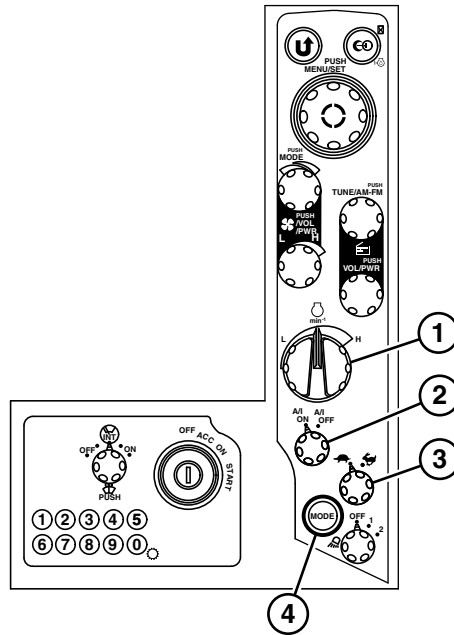

TX1086753 —UN—11JAN11

Switch Panel

- 1— Engine Speed Dial
- 2— Auto-Idle Switch
- 3— Travel Mode Switch
- 4— Power Mode Button

Turn auto-idle switch (2) to A/I OFF.

Place pilot shutoff lever in locked (UP) position.

Turn engine speed dial (1) clockwise.

LISTEN: Does engine speed increase?

Turn engine speed dial counterclockwise.

LISTEN: Does engine speed decrease?

YES: Go to next check.

NO: Check data converter and main controller battery power 5 A fuse (marked CONTROLLER) (F10). See Replacing Fuses. (Section 4-1.)

IF OK: See an authorized John Deere dealer.

Continued on next page

KR46761,000131D -19-15SEP22-23/51

- 1— Rotate Grapple Clockwise
- 2— Rotate Grapple Counterclockwise
- 3— Horn Button
- 4— Grapple Open
- 5— Grapple Closed
- 6— Power Boost Button
- 7— Arm Out
- 8— Arm In
- 9— Swing Left
- 10— Swing Right
- 11— Boom Lower
- 12— Boom Raise
- 13— Tilt In
- 14— Tilt Out
- 15— Grapple Saw Button (if equipped)
- 16— Free Swing Button (if equipped)
- 17— Outrigger Raise Button (if equipped)
- 18— Outrigger Lower Button (if equipped)

 **CAUTION:** Prevent possible injury from unexpected machine movement. Clear all persons from the area before operating machine.

Turn engine speed dial to L (slow idle) position.

Place pilot shutoff lever in unlocked (DOWN) position.

Slowly move hydraulic levers to all positions.

LOOK: Does pilot control lever operate functions properly according to pattern of machine configuration?

YES: Go to next check.

NO: See an authorized John Deere dealer.

Continued on next page

KR46761,000131D -19-15SEP22-33/51

Travel System Tracking Check

⚠ CAUTION: Prevent possible injury from unexpected machine movement. Clear all persons from the area before operating machine.

Warm hydraulic oil to operating temperature for this check.

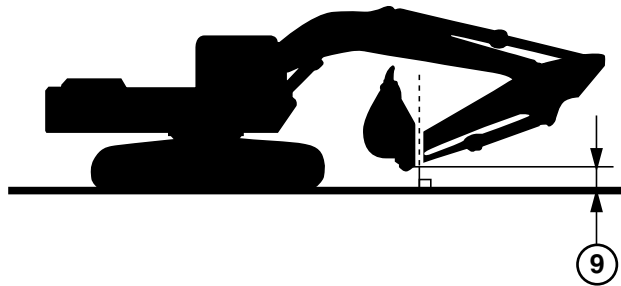

TX1120783 —UN—20AUG12

Machine Position

9— Attachment Height

Fully extend arm cylinder and attachment cylinder.

Position boom so attachment height (9) is approximately 400 mm (16 in) above ground.

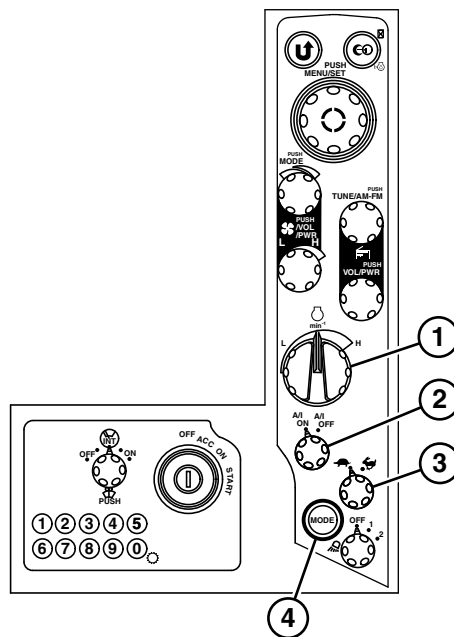

TX1086753 —UN—11JAN11

Switch Panel

- 1— Engine Speed Dial**
- 2— Auto-Idle Switch**
- 3— Travel Mode Switch**
- 4— Power Mode Button**

Turn engine speed dial (1) to H (fast idle) position.

Turn auto-idle switch (2) to A/I OFF position.

Turn travel mode switch (3) to fast speed (rabbit) mode.

Press power mode button (4) until PWR (power) mode is displayed on monitor.

Continued on next page

KR46761,000131D -19-15SEP22-43/51

Miscellaneous—Troubleshooting

Troubleshooting Procedure

NOTE: Troubleshooting charts are arranged from the simplest to verify, to least likely, more difficult to verify. When diagnosing a problem, use all possible means to isolate the problem to a single component or system. Use the following steps to diagnose problems:

Step 1. Operational Checkout Procedure

Step 2. Troubleshooting Charts

Step 3. Adjustments

Step 4. See your authorized John Deere dealer.

TX, TROUBLESHOOT -19-20JAN11-1/1

Symptom	Problem	Solution
	Batteries undercharged or dead	Recharge or replace.
	Battery cables making poor connections	Clean and tighten connections.
	Fuse	Check POWER ON 5 A fuse (F17). Replace if necessary.
	Starter	Repair or replace starter. See an authorized John Deere dealer.
	Starter pinion jammed in flywheel gear	Repair or replace starter or ring gear. See an authorized John Deere dealer.
Starter Turns but Will Not Crank Engine	Starter	Repair or replace starter. See an authorized John Deere dealer.
Engine Cranks Slowly	Battery cables damaged or broken internally	Inspect and replace cables.
	Battery or starter cable connections loose or corroded	Clean and tighten connections.
	Batteries undercharged or dead	Recharge or replace.
	Low battery voltage	Recharge or replace.
	Starter	Repair or replace starter. See an authorized John Deere dealer.
Starter Continues to Run After Engine Starts	Starter	Repair or replace starter. See an authorized John Deere dealer.
	Key switch malfunction	Disconnect battery ground. See an authorized John Deere dealer.
	Starter relay	Disconnect battery ground. See an authorized John Deere dealer.
Charging Indicator Light On, Engine Running	Loose or corroded electrical connections on battery, ground strap, starter, or alternator	Inspect, clean, or tighten electrical connections.
	Worn drive belt	Replace belt.
	Fuse	Check CONTROLLER 5 A fuse (F10). Check ECU P1 20 A fuse (F8). Check ALT 70 A fuse (F61). Replace if necessary.

Continued on next page

KR46761,000116F -19-02JUL18-2/3

Miscellaneous—Specifications

Item	Measurement	Specification
2—Machine Transport	Length (SN - 1FF2654GJND260215) (SN - 1FF2654GKPC260240)	10 160 mm 33 ft 4 in
	Length (SN 1FF2654GJND260216 -) (SN 1FF2654GKPC260241 -)	10 290 mm 33 ft 9 in
3—Rear End Swing	Radius (SN - 1FF2654GJND260215) (SN - 1FF2654GKPC260240)	3150 mm 10 ft 4 in
	Radius (SN 1FF2654GJND260216 -) (SN 1FF2654GKPC260241 -)	3205 mm 10 ft 6 in
4—Sprocket Center to Idler Center		
2620 mm (8 ft 7 in) Undercarriage	Distance	3730 mm 12 ft 3 in
2790 mm (9 ft 2 in) Undercarriage	Distance	4060 mm 13 ft 4 in
5—Undercarriage		
2620 mm (8 ft 7 in) Undercarriage	Length	4070 mm 13 ft 4 in
2790 mm (9 ft 2 in) Undercarriage	Length	5030 mm 16 ft 6 in
6—Counterweight	Clearance	1400 mm 4 ft 7 in
7—Cab		
Side Entry Cab	Height	3840 mm 12 ft 7 in
Rear Entry Cab	Height	5180 mm 17 ft 0 in
Rear Entry Cab—Tilted	Height	3760 mm 12 ft 4 in
8—Upperstructure	Width	3377 mm 11 ft 1 in
9—Minimum Ground		
2620 mm (8 ft 7 in) Undercarriage	Clearance	710 mm 2 ft 4 in
2790 mm (9 ft 2 in) Undercarriage	Clearance	760 mm 2 ft 6 in
10—Center of Sprocket to Center of Sprocket		
2620 mm (8 ft 7 in) Undercarriage	Distance	2620 mm 8 ft 7 in
2790 mm (9 ft 2 in) Undercarriage	Distance	2790 mm 9 ft 2 in
11—Track Shoe	Width	660 mm (26 in) 700 mm (28 in) 800 mm (32 in)

Continued on next page

KR46761.000130A -19-20DEC22-2/4

Miscellaneous—Specifications

Item	Measurement	Specification
1—Maximum Digging Reach at Ground Level	Distance	8640 mm 28 ft 4 in
2—Maximum Digging Reach	Distance	8940 mm 29 ft 4 in
3—Maximum Digging	Depth	4850 mm 15 ft 11 in
4—Maximum Cutting	Height	9880 mm 32 ft 5 in
5—Maximum Dumping	Height	7470 mm 24 ft 6 in
6—Minimum Swing	Radius	2820 mm 9 ft 3 in
7—Tail Swing	Radius (SN - 1FF2654GJND260215)	3150 mm
	(SN - 1FF2654GKPC260240)	10 ft 4 in
	Radius (SN 1FF2654GJND260216 -)	3271 mm
	(SN 1FF2654GKPC260241 -)	10 ft 9 in

KR46761,000130D -19-20DEC22-2/2

Index

	Page
A	
Access	
Door	3-2-3
Access light	
Switch	
If equipped.....	2-1-5, 2-1-9, 2-1-10
Accessory power port	
Rear panel	2-1-3
Adjustment	
Armrest	2-1-23, 2-1-27
Seat.....	2-1-23, 2-1-27
Track sag	3-3-6
Air conditioner	
Cab	2-1-14
V-belt	
Inspect.....	3-7-8
Air conditioner condenser	
Clean.....	4-1-3
Air conditioner display	2-2-1
Air suspension	
Seat.....	2-1-23
Alarm	
Hydraulic oil level	
If equipped.....	2-1-20
Alternative	
Exit.....	2-1-21
Alternator	
Precautions.....	4-1-6
Arm drift	
Operational check.....	4-2-33
Armrest	
Adjustment.....	2-1-23, 2-1-27
Attachment combo	
Control levers	
Operation	
If equipped.....	2-3-10
Switch	
If equipped.....	2-1-9, 2-1-13
Attachment drift	
Operational check.....	4-2-33
Attachments	
Adding safely	1-3-7
Operating safely.....	1-3-7
Auto shutdown indicator	2-2-1
Auto-idle	
Switch	2-1-1
Function.....	2-1-2
Auto-idle circuit	
Operational check.....	4-2-21
Auto-idle indicator.....	2-2-1
Auxiliary indicator	2-2-1
Avoid static electricity risk when fueling	1-2-5

	Page
B	
Back	
Button.....	2-1-1
Function.....	2-1-2
Backover Accidents	1-3-4
Battery	
Acid burns	3-7-5
Booster batteries.....	4-1-10
Clean and tighten.....	3-3-10
Disconnect switch	2-3-3
Electrolyte level check	3-7-5
Explosion	3-7-5
Handling, checking, and servicing	4-1-7
Replace.....	4-1-10
Specifications.....	4-1-10
Terminals.....	3-7-5
Using charger.....	4-1-8
Battery charger	
Using.....	4-1-8
Before starting work.....	2-3-1
Belt	
Air Conditioner	
Inspect.....	3-7-8
Serpentine	
Inspect.....	3-9-6
Biodiesel fuel	3-1-4
Blower speed	
Switch	2-1-1
Function.....	2-1-2
Bolt and screw torque values	
Metric	4-1-22
Unified inch	4-1-21
Boom drift	
Operational check.....	4-2-33
Boom lower	
With engine stopped	2-3-15
Boost starting.....	4-1-10
Break-In engine oil.....	3-1-8
Breather	
Fuel tank	3-9-10
Bucket	
Heavy-duty tooth, replace	4-1-17
Removal.....	4-1-18
Tooth replacement	4-1-17
Tooth, replace	4-1-16
Button	
Back.....	2-1-1
Function.....	2-1-2
Home	2-1-1
Function.....	2-1-2
Horn	2-1-4
Power boost.....	2-1-4
Power mode.....	2-1-1
Function.....	2-1-2

Continued on next page

CLICK HERE TO **DOWNLOAD** THE COMPLETE MANUAL

- Thank you very much for reading the preview of the manual.
- You can download the complete manual from: www.heydownloads.com by clicking the link below



- Please note: If there is no response to CLICKING the link, please download this PDF first and then click on it.

CLICK HERE TO **DOWNLOAD** THE COMPLETE MANUAL