

# 2654G and 2654GLC Forestry Excavator

(PIN: 1FF2654G\_\_F260001— )



## OPERATOR'S MANUAL

### 2654G and 2654GLC Forestry Excavator (PIN: 1FF2654G\_\_F260001— )

OMT388071X19 ISSUE A3 (ENGLISH)

CALIFORNIA  
Proposition 65 Warning

Diesel engine exhaust and some of its constituents are known to the State of California to cause cancer, birth defects, and other reproductive harm.

If this product contains a gasoline engine:

**⚠ WARNING**

The engine exhaust from this product contains chemicals known to the State of California to cause cancer, birth defects or other reproductive harm.

The State of California requires the above two warnings.

CLICK HERE TO **DOWNLOAD** THE COMPLETE MANUAL

- Thank you very much for reading the preview of the manual.
- You can download the complete manual from: [www.heydownloads.com](http://www.heydownloads.com) by clicking the link below



- Please note: If there is no response to CLICKING the link, please download this PDF first and then click on it.

CLICK HERE TO **DOWNLOAD** THE COMPLETE MANUAL

## Emissions Control System Certification Label

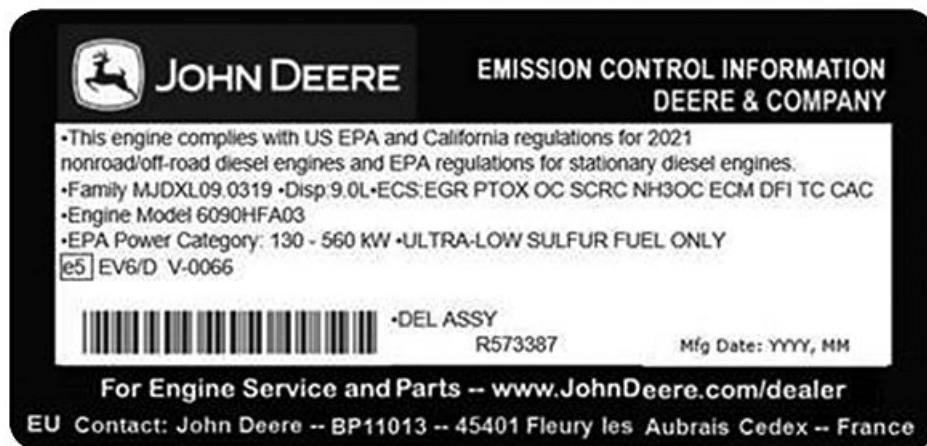

Engine Emissions Label

**⚠ CAUTION: Statutes providing severe penalties for tampering with emissions controls may apply to the user or dealer.**

The emissions warranty applies to those engines marketed by John Deere that have been certified by the United States Environmental Protection Agency (EPA) and/or California Air Resources Board (CARB); and used in the United States and Canada in Non-road equipment. The presence of an emissions label like the one shown signifies that the engine has been certified with the EPA and/or CARB. The EPA and CARB warranties only apply to new engines having the certification label affixed to the engine and sold as stated above in the geographic areas. The presence of an EU number signifies that the engine has been certified with the European Union countries per Regulation (EU) 2016/1628 and supplementing legislation. The EPA and/or CARB emissions warranties do not apply to the EU countries.

The emissions label has applicable US EPA and/or CARB regulatory year. The regulatory year determines which warranty statement is applicable to engine. See “EPA Non-road Emissions Control Warranty Statement—Compression Ignition” and “CARB Non-road Emissions Control Warranty Statement—Compression Ignition”. For additional regulatory year warranty statements, see [www.JohnDeere.com](http://www.JohnDeere.com) or contact the nearest John Deere service dealer for assistance.

#### Emission Control System(s) Laws

The U.S. EPA and California ARB prohibit the removal or rendering inoperative of any device or element of design installed on or in engines/equipment in compliance with applicable emission regulations prior to or after the sale and delivery of the engines/equipment to the ultimate purchaser.

DX,EMISSIONS,LABEL -19-05FEB21-1/1

RG33429—UN—04FEB21

**JOHN DEERE'S WARRANTY RESPONSIBILITY:**

Where a warrantable condition exists, John Deere will repair or replace, as it elects, your off-road diesel engine at no cost to you, including diagnosis, parts or labor. Warranty coverage is subject to the limitations and exclusions set forth herein. The off-road diesel engine is warranted for a period of five years from the date the engine is delivered to an ultimate purchaser or 3,000 hours of operation, whichever occurs first. The following are emissions-related parts:

<p><b>Air Induction System</b></p> <ul style="list-style-type: none"> <li>• Intake manifold</li> <li>• Turbocharger</li> <li>• Charge air cooler</li> </ul> <p><b>Fuel Metering system</b></p> <ul style="list-style-type: none"> <li>• Fuel injection system</li> </ul> <p><b>Exhaust Gas Recirculation</b></p> <ul style="list-style-type: none"> <li>• EGR valve</li> </ul> <p><b>Catalyst or Thermal Reactor Systems</b></p> <ul style="list-style-type: none"> <li>• Catalytic converter</li> <li>• Exhaust manifold</li> </ul>	<p><b>Emission control labels</b></p> <p><b>Particulate Controls</b></p> <ul style="list-style-type: none"> <li>• Any device used to capture particulate emissions</li> <li>• Any device used in the regeneration of the capturing system</li> <li>• Enclosures and manifolding</li> <li>• Smoke Puff Limiters</li> </ul> <p><b>Positive Crankcase Ventilation (PCV) System</b></p> <ul style="list-style-type: none"> <li>• PCV valve</li> <li>• Oil filler cap</li> </ul>	<p><b>Advanced Oxides of Nitrogen (NOx) Controls</b></p> <ul style="list-style-type: none"> <li>• NOx absorbers and catalysts</li> </ul> <p><b>SCR systems and urea containers/dispensing systems</b></p> <p><b>Miscellaneous Items used in Above Systems</b></p> <ul style="list-style-type: none"> <li>• Electronic control units, sensors, actuators, wiring harnesses, hoses, connectors, clamps, fittings, gasket, mounting hardware</li> </ul>
--	---	--

Any warranted emissions-related part scheduled for replacement as required maintenance is warranted by John Deere for the period of time prior to the first scheduled replacement point for the part. Any warranted emissions-related part not scheduled for replacement as required maintenance or scheduled only for regular inspection is warranted by John Deere for the stated warranty period.

**OWNER'S WARRANTY RESPONSIBILITIES:**

As the off-road diesel engine owner you are responsible for the performance of the required maintenance listed in your Operator's Manual. John Deere recommends that the owner retain all receipts covering maintenance on the off-road diesel engine, but John Deere cannot deny warranty solely for the lack of receipts or for the owner's failure to ensure the performance of all scheduled maintenance. However, as the off-road diesel engine owner, you should be aware that John Deere may deny you warranty coverage if your off-road diesel engine or a part has failed due to abuse, neglect, improper maintenance or unapproved modifications.

The off-road diesel engine is designed to operate on diesel fuel as specified in the Fuels, Lubricants and Coolants section in the Operators Manual. Use of any other fuel may result in the engine no longer operating in compliance with applicable emissions requirements.

The owner is responsible for initiating the warranty process, and should present the machine to the nearest authorized John Deere dealer as soon as a problem is suspected. The warranty repairs should be completed by the authorized John Deere dealer as quickly as possible.

Emissions regulations require the customer to bring the unit to an authorized servicing dealer when warranty service is required. As a result, John Deere is NOT liable for travel or mileage on emissions warranty service calls.

Emission\_CI\_CARB (14Apr20)

DX,EMISSIONS,CARB -19-26AUG20-8/8

RG32759 —UN—19AUG20

**Emissions Performance and Tampering**

**Operation and Maintenance**

The engine, including the emissions control system, shall be operated, used, and maintained in accordance with the instructions provided in this manual to maintain the emissions performance of the engine within the requirements applicable to the engine's category/certification.

**Tampering**

No deliberate tampering with or misuse of the engine emissions control system shall take place; in particular with regard to deactivating or not maintaining an exhaust gas recirculation (EGR) or a DEF dosing system. Tampering with an engine's emissions control system will void the European Union (EU) type approval and applicable emissions-related warranties.

DX,EMISSIONS,PERFORM -19-12JAN18-1/1

# Contents

Page	Page
<b>Safety—Safety and Operator Conveniences</b>	
Safety and Operator Convenience Features ..... 1-1-1	
<b>Safety—General Precautions</b>	
Information for European Union	
Directives and Eurasian Economic	
Union Technical Regulations Compliance ..... 1-2-1	
Recognize Safety Information ..... 1-2-2	
Follow Safety Instructions ..... 1-2-3	
Prepare for Emergencies ..... 1-2-3	
Operate Only If Qualified ..... 1-2-3	
Wear Protective Equipment ..... 1-2-4	
Protect Against Noise ..... 1-2-4	
Avoid Unauthorized Machine Modifications ..... 1-2-4	
Control Pattern ..... 1-2-4	
Control Pattern Selector—If Equipped ..... 1-2-5	
Inspect Machine ..... 1-2-5	
Stay Clear of Moving Parts ..... 1-2-5	
Avoid High-Pressure Fluids ..... 1-2-5	
Avoid High-Pressure Oils ..... 1-2-6	
Work In Ventilated Area ..... 1-2-6	
Avoid Static Electricity Risk When Refueling ..... 1-2-7	
Prevent Fires, Clean Debris From Machine ..... 1-2-8	
In Case of Machine Fire ..... 1-2-8	
Clean Debris from Machine ..... 1-2-9	
Prevent Battery Explosions ..... 1-2-9	
Handle Chemical Products Safely ..... 1-2-9	
Handle Starting Fluid Safely ..... 1-2-10	
Decommissioning — Proper Recycling	
and Disposal of Fluids and Components ..... 1-2-10	
Exhaust Filter Ash Handling and Disposal ..... 1-2-10	
Add Cab Guarding for Special Uses ..... 1-2-11	
<b>Safety—Operating Precautions</b>	
Use Steps and Handholds Correctly ..... 1-3-1	
Start Only From Operator's Seat ..... 1-3-1	
Use and Maintain Seat Belt ..... 1-3-1	
Heated and Ventilated Operator's Seat ..... 1-3-2	
Prevent Unintended Machine Movement ..... 1-3-2	
Avoid Work Site Hazards ..... 1-3-3	
Keep Riders Off Machine ..... 1-3-3	
Avoid Backover Accidents ..... 1-3-4	
Avoid Machine Tip Over and Machine	
Damage ..... 1-3-4	
Use Special Care When Lifting Objects ..... 1-3-5	
Use Care When Swinging Machine ..... 1-3-5	
Operate Boom With Care ..... 1-3-5	
Avoid Power Lines ..... 1-3-6	
Operating on Slopes ..... 1-3-6	
Inspect and Maintain ROPS ..... 1-3-6	
Keep the Operator Protective Structure	
(OPS) in Place ..... 1-3-6	
Travel Safely ..... 1-3-7	
Prevent Acid Burns ..... 1-3-7	
Add and Operate Attachments Safely ..... 1-3-7	
Saw Chain Hazard ..... 1-3-8	
<b>Safety—Maintenance Precautions</b>	
Park and Prepare for Service Safely ..... 1-4-1	
Service Machines Safely ..... 1-4-1	
Service Cooling System Safely ..... 1-4-2	
Remove Paint Before Welding or Heating ..... 1-4-2	
Make Welding Repairs Safely ..... 1-4-2	
Drive Metal Pins Safely ..... 1-4-3	
Use Proper Lifting Equipment ..... 1-4-3	
Clean Exhaust Filter Safely ..... 1-4-4	
Chain Shot Guard Inspection ..... 1-4-5	
<b>Safety—Safety Signs and Other Instructions</b>	
Safety Signs and Other Instructions ..... 1-5-1	
<b>Operation—Operator's Station</b>	
Pedals, Levers, and Panels ..... 2-1-1	
Switch Panel ..... 2-1-1	
Switch Panel Functions ..... 2-1-2	
Rear Panel ..... 2-1-3	
Horn Button ..... 2-1-4	
Power Boost Button ..... 2-1-4	
Pilot Shutoff Lever ..... 2-1-5	
Left Console ..... 2-1-5	
Travel Alarm and Travel Alarm Cancel Switch ..... 2-1-6	
Cab Dome Light Switch ..... 2-1-6	
Horn Switch—Processor Only ..... 2-1-6	
Reversing Fan Switch—If Equipped ..... 2-1-7	
Max Speed Program Switch—If Equipped ..... 2-1-7	
Hydraulic Oil Tank Pressure Vent	
Switch—If Equipped ..... 2-1-8	
Right Console ..... 2-1-9	
Exhaust Filter Parked Cleaning Switch ..... 2-1-10	
Service and Access Lights Switch—If	
Equipped ..... 2-1-11	
Service ADVISOR™ Remote (SAR) Switch ..... 2-1-12	
USB Charge Port—If Equipped ..... 2-1-13	

Continued on next page

*Original Instructions. All information, illustrations and specifications in this manual are based on the latest information available at the time of publication. The right is reserved to make changes at any time without notice.*

COPYRIGHT © 2023  
DEERE & COMPANY  
Moline, Illinois  
All rights reserved.  
A John Deere ILLUSTRATION™ Manual  
Previous Editions  
Copyright © 2019, 2020, 2021, 2022

## Follow Safety Instructions

Carefully read all safety messages in this manual and on your machine safety signs. Keep safety signs in good condition. Replace missing or damaged safety signs. Use this operator's manual for correct safety sign placement. Be sure that new equipment components and repair parts include the current safety signs. Replacement safety signs are available from your John Deere dealer.

There can be additional safety information contained on parts and components sourced from suppliers that is not reproduced in this operator's manual.

Learn how to operate the machine and how to use controls properly. Do not let anyone operate without instruction.

Keep your machine in proper working condition. Unauthorized modifications to the machine could impair the function or safety and affect machine life.

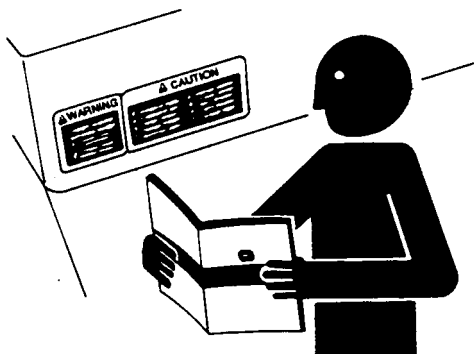

TS201—UN—15APR13

If you do not understand any part of this manual and need assistance, contact your John Deere dealer.

TX,FOLLOW -19-20JAN11-1/1

## Prepare for Emergencies

Be prepared if a fire starts.

Keep a first aid kit and fire extinguisher handy.

Keep emergency numbers for doctors, ambulance service, hospital, and fire department near your telephone.

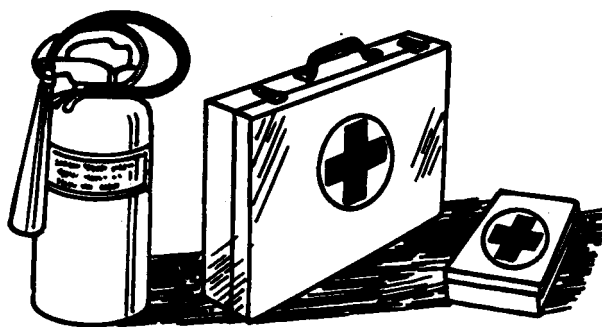

TS291—UN—15APR13

DX,FIRE2 -19-03MAR93-1/1

## Operate Only If Qualified

Do not operate this machine unless the operator's manual has been read carefully, and you have been qualified by supervised training and instruction.

Operator should be familiar with the job site and surroundings before operating. Try all controls and

machine functions with the machine in an open area before starting to work.

Know and observe all safety rules that may apply to every work situation and work site.

TX,QUALIFIED -19-18JAN11-1/1

### Heated and Ventilated Operator's Seat

An overheated seat heater can cause a burn injury or damage to the seat. To reduce the risk of burns, use caution when using the seat heater for extended periods of time, especially if the operator cannot feel temperature change or pain to the skin. Do not place objects on the seat, such as a blanket, cushion, cover, or similar item, which can cause the seat heater to overheat.



H124189 —UN—11MAY18

DX,SEATHEATER -19-20NOV18-1/1

### Prevent Unintended Machine Movement

Be careful not to accidentally actuate control levers when coworkers are present. Pull pilot shutoff lever to locked (UP) position during work interruptions. Pull pilot shutoff lever to locked (UP) position and stop engine before allowing anyone to approach machine.

Always lower work equipment to the ground and pull pilot shutoff lever to locked (UP) position before standing up or leaving the operator's seat. Stop engine before exiting.

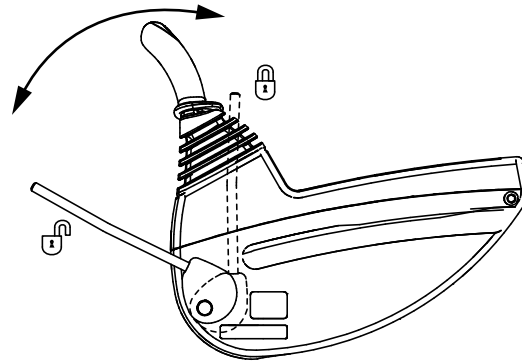

T216779 —UN—22NOV05

VD76477,000036D -19-19APR11-1/1

## Clean Exhaust Filter Safely

During exhaust filter cleaning operations, the engine may run at elevated idle and hot temperatures for an extended period of time. Exhaust gases and exhaust filter components reach temperatures hot enough to burn people, or ignite or melt common materials.

Keep machine away from people, animals, or structures which may be susceptible to harm or damage from hot exhaust gases or components. Avoid potential fire or explosion hazards from flammable materials and vapors near the exhaust. Keep exhaust outlet away from people and anything that can melt, burn, or explode.

Closely monitor machine and surrounding area for smoldering debris during and after exhaust filter cleaning.

Adding fuel while an engine is running can create a fire or explosion hazard. Always stop engine before refueling machine and clean up any spilled fuel.

Always make sure that engine is stopped while hauling machine on a truck or trailer.

Contact with exhaust components while still hot can result in serious personal injury.

Avoid contact with these components until cooled to safe temperatures.

If service procedure requires engine to be running:

- Only engage power-driven parts required by service procedure
- Ensure that other people are clear of operator station and machine

Keep hands, feet, and clothing away from power-driven parts.

Always disable movement (neutral), set the parking brake or mechanism and disconnect power to attachments or tools before leaving the operator's station.

Shut off engine and remove key (if equipped) before leaving the machine unattended.

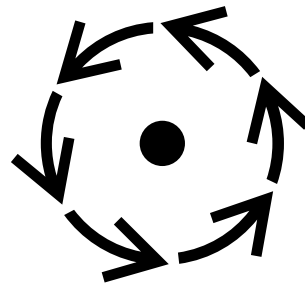
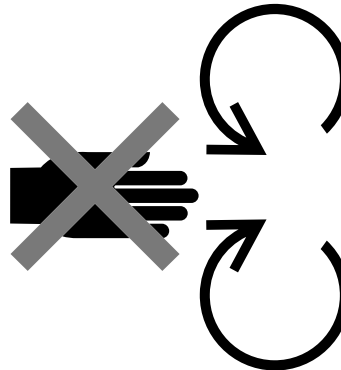
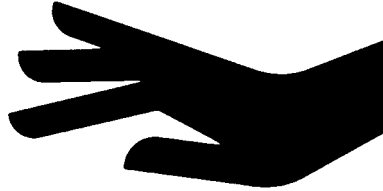

**STOP**

TS227 —UN—15APR13

TS271 —UN—23AUG88

TS1693 —UN—09DEC09

TS1695 —UN—07DEC09

DX,EXHAUST,FILTER -19-12JAN11-1/1

### 15. CAUTION, Hydraulic Reservoir Cap

- Before removing hydraulic reservoir cap and air breather always stop engine.
- Do not remove cap when oil temperature is hot.
- Do not loosen drain plug when oil temperature is hot.

This safety label is located on top of the hydraulic tank.

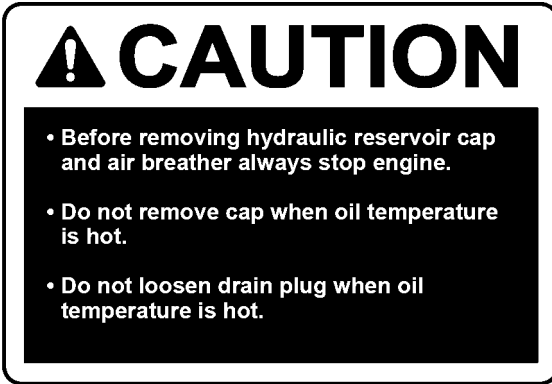

CAUTION, Hydraulic Reservoir Cap

px7bwb6,1660593212580 -19-17AUG22-16/58

TX1212346 —19—09MAR16

### 16. CAUTION, Prevent Machine Fires

#### PREVENT MACHINE FIRES

Keep engine compartment and other machine areas free of trash and debris. Clean daily.

Check for fuel or oil leaks every day. Repair and clean up spills immediately.

Keep fire extinguishers on machine and properly maintained. Recharge immediately after use.

These safety labels are located inside the left front service door and right rear service door.



CAUTION, Prevent Machine Fires

px7bwb6,1660593212580 -19-17AUG22-17/58

TX1210058 —19—17FEB16

### 17. Tiedowns

Route appropriate tiedown device through tiedown points.

These labels are located strategically throughout machine.

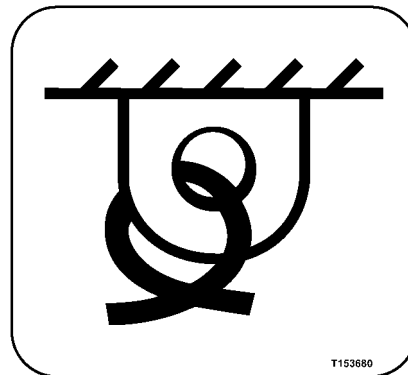

Tiedown

Continued on next page

px7bwb6,1660593212580 -19-17AUG22-18/58

TX1166256 —UN—24JUL14

### 10. CAUTION, Operate Machine Safely

- AVOID DEATH OR SERIOUS INJURY - READ AND UNDERSTAND THE OPERATOR'S MANUAL AND SAFETY MANUAL PRIOR TO OPERATING THIS MACHINE.
- Controls may be changed for attachment or operator preference. Try control pattern before operating.
- Always lower working tools to the ground and engage hydraulic control lockout lever before leaving operator's seat.
- Keep riders off machine.
- Avoid contact between boom/attachments and overhead obstacles whenever operating, traveling or transporting machine.
- Keep bystanders clear of machine; especially before moving boom, swinging upperstructure or traveling.
- Upperstructure position affects travel direction. Try pedals or levers to determine travel direction before moving machine.
- Avoid tipping - Do not lift or move objects that exceed machine stability.
- Avoid parking machine on an incline.

This safety label is located inside the cab on the cab door.

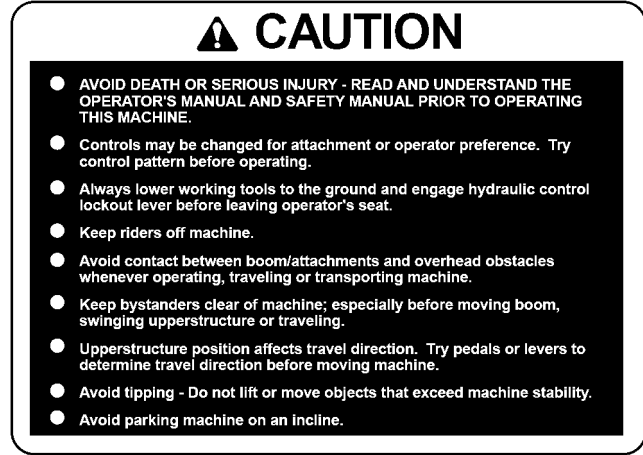

*CAUTION, Operate Machine Safely*

px7bwb6,1660593212580 -19-17AUG22-41/58

TX121399 —19—24FEB16

### 11. Lifting Points

Route appropriate lifting device through lifting points.  
These labels are located strategically throughout machine.

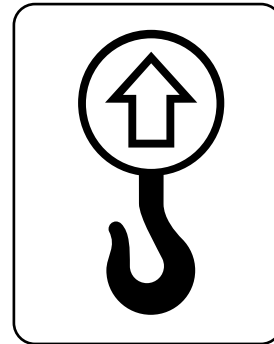

*Lifting Point*

Continued on next page

px7bwb6,1660593212580 -19-17AUG22-42/58

TX1166778 —UN—23JUL14

**14. Key Switch**—Switch has four positions:

- OFF
- ACC
- ON
- START

- Press keypad numbers 1—8 while radio is on to switch between programmed stations.
- When work light switch is on position 2, monitor changes to night mode (background lighting is dimmed). Press and hold number 0 on keypad to adjust monitor back to daytime mode display.

**15. Keypad**—Keypad has different applications:

- Use numbers 0—9 to enter password at machine start-up if equipped.

KR46761,0001154 -19-14DEC16-2/2

**Rear Panel**

**Lighter (1):** For operator convenience. Can also be used as an electrical port for 24-volt appliances only.

**Accessory Power Port (2):** 12-volt, 5-amp electrical port provided for service and maintenance.

**Fuse Box Cover (3):** Prevents damage to fuses. For more on fuses, see Replacing Fuses. (Section 4-1.)

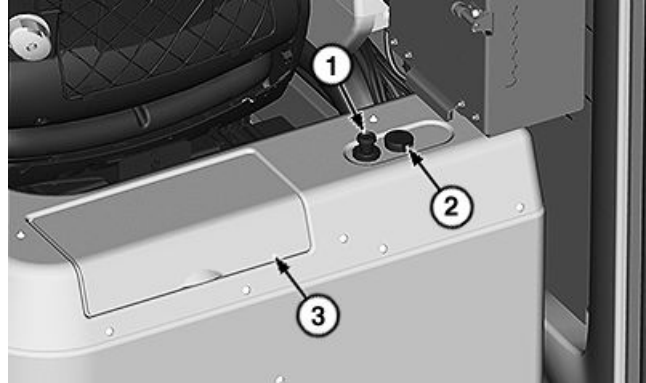

Rear Panel—Rear Entry Cab

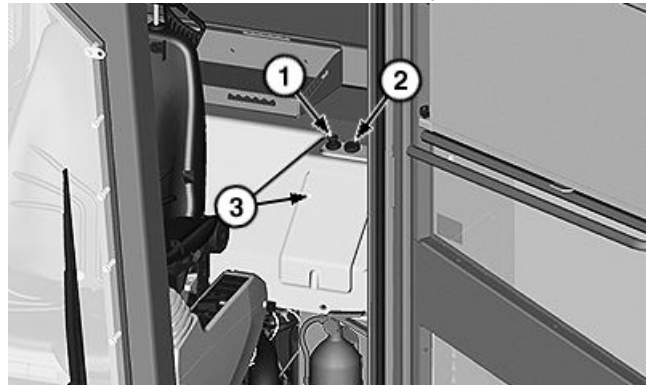

Rear Panel—Side Entry Cab

KR46761,00010FB -19-18NOV16-1/1

TX1213195—UN—22MAR16

TX1213194—UN—22MAR16

## USB Charge Port—If Equipped

The USB charge port (3) allows operator to charge USB-connected devices only. The USB charge port will not transfer data to or from a connected device.

The USB charge port location (1) for machines not equipped with satellite radio is on the right console.

The USB charge port location for machines equipped with satellite radio is on the right side wall behind the operator's seat.

1. Open USB charge port cover (2).
2. Connect device to USB charge port with a USB cord.
3. Turn key switch to the ACC or ON position to charge a connected device.

1— USB Charge Port Location    3— USB Charge Port  
2— USB Charge Port Cover

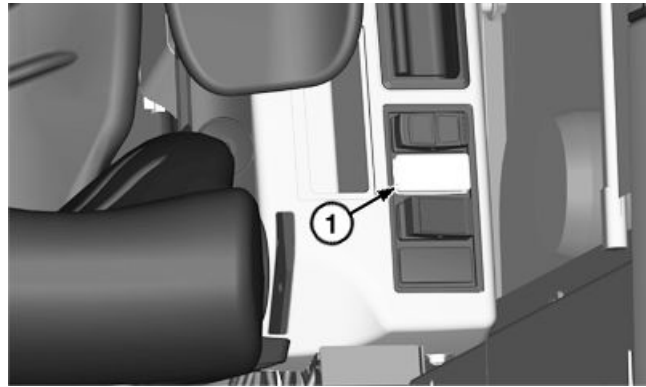

TX1260701A—UN—13JUL18

USB Charge Port Location (machines not equipped with satellite radio)

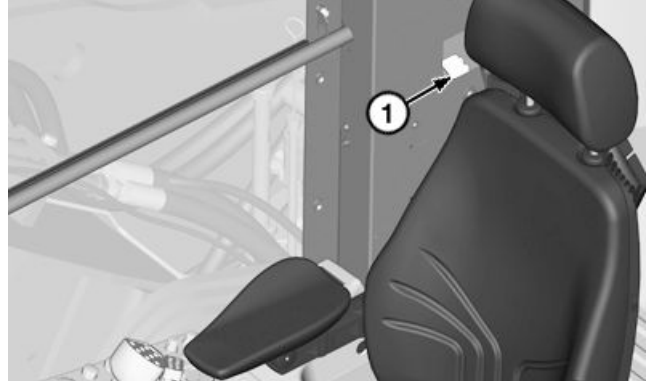

TX1260702A—UN—13JUL18

USB Charge Port Location (machines equipped with satellite radio)

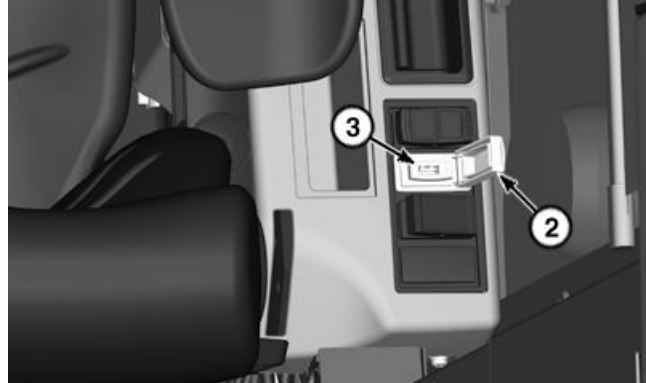

TX1260704A—UN—13JUL18

USB Charge Port Cover

TD48962.00000E4 -19-25JUL18-1/1

### Rear Entry Cab—Knob Latch

The skylight provides an alternative exit path if the cab door is blocked in an emergency situation.

Remove pins (1), loosen knobs (2), and push on skylight pane to remove and to open exit path.

1— Pin (2 used)

2— Knob (2 used)



TX1314651A —UN—12JUL21

Alternative Exit

KR46761.0001112 -19-04AUG21-2/3

### Side Entry Cab

The rear window provides an alternative exit path if the cab door is blocked in an emergency situation.

*NOTE: There are also knobs on the outside of the cab that can open the rear window.*

Loosen knobs (1) and push on rear window pane to remove and to open exit path.

The skylight is another alternative exit. See Rear Entry Cab in this section.

1— Knob (4 used)

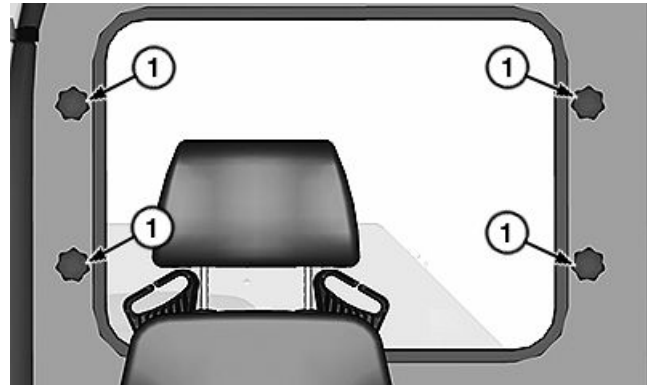

TX1213129 —UN—21MAR16

Alternative Exit

KR46761.0001112 -19-04AUG21-3/3

**22. Alarm Indicators:** Displays if an abnormality occurs. If six or more alarms are generated, the indicators can be scrolled through using the monitor dial on the switch

panel. For more information, see Main Menu—Alarm List in this section.

KR46761,00013EA -19-30JAN17-2/2

• **Diesel Exhaust Fluid (DEF) Alarm**—Diesel exhaust fluid (DEF) tank is empty or DEF quality is poor. Engine power is derated. Refill DEF tank as soon as possible.

TX1156518 —UN—20MAR14



*Diesel Exhaust Fluid (DEF) Alarm*

**Monitor Display Messages**

The monitor automatically displays a message for specific machine situations and certain diagnostic trouble codes (DTCs). Depending on machine situation or if a DTC is

initially active, a message displays on the monitor until the situation changes or the DTC is resolved.

Display Message	Message Trigger
Exhaust Filter Cleaning Failed Aborted by Operator Cleaning Incomplete	The cleaning process was discontinued due to one of the following conditions: <ul style="list-style-type: none"> <li>• Pilot shutoff lever is moved.</li> <li>• Engine speed dial is moved.</li> <li>• Parked cleaning is aborted due to a system fault.</li> <li>• Engine runs out of fuel.</li> <li>• Engine is shut off by operator (not recommended).</li> </ul>
Exhaust Filter Cleaning Complete	Exhaust filter cleaning complete and machine is ready to return to operation.
REFILL DEF DEF Tank Level Low	DEF tank level is low.
REFILL DEF DEF Tank Empty Engine Power Limited	DEF tank level is empty.
REFILL DEF DEF Tank Empty Engine Power and Speed Limited	DEF tank level is empty.
DEF System Fault Engine Power and Speed Limited Check Active Codes	Initiated by active code.
DEF Quality Poor Engine Power and Speed Limited Check Active Codes	Poor DEF quality detected.
DEF System Fault Engine Power and Speed Limited Check Active Codes	Initiated by active code.

KR46761,00014A6 -19-30JAN17-27/27

## Main Menu—Setting Menu—Display Item Selection

**NOTE:** Only one display item can be selected at a time. When one of the selections is ON, the color of the preceding square is green.

The **Display Item Selection** menu provides the capability to change what appears on the default screen.

At Setting Menu, rotate monitor dial to highlight Display Item Selection. Press monitor dial to display Display Item Selection menu.

Display Item Selection menu items include:

- Logo**  
Rotate monitor dial to highlight Logo. Press monitor dial to have manufacturer logo (1) appear on default screen.
- Operational Information**  
Rotate monitor dial to highlight Operational Information. Press monitor dial to have operational information (2) appear on default screen.
- OFF (Disable)**  
Rotate monitor dial to highlight OFF (disable). Press monitor dial to turn OFF any images.

Press back button to return to previous screen.

Press home button to return to default screen.

1— Manufacturer Logo

2— Operational Information



Manufacturer Logo



Operational Information

TX1160742A—UN—15MAY14

TX1160743A—UN—15MAY14

CN93077,000023F -19-31AUG15-1/1

## Main Menu—Setting Menu—Brightness Adjustment

The **Brightness Adjustment** menu allows operator to adjust the brightness of the monitor for better viewing.

At Setting Menu, rotate monitor dial to highlight Brightness Adjustment. Press monitor dial to display Brightness Adjustment menu.

Rotate monitor dial clockwise for lighter image and counterclockwise for darker image.

Press back button to return to previous screen.

Press home button to return to default screen.

OUT4001,000072C -19-31AUG15-1/1

## Main Menu—Setting Menu—Language

The **Language** menu allows operator to change the language text that appears on the monitor to a specific preference.

At Setting Menu, rotate monitor dial to highlight Language. Press monitor dial to display Language menu. A list of different languages appears.

**NOTE:** Only one language can be selected at a time. When one of the selections is ON, the color of the preceding square is green.

Rotate monitor dial to highlight desired language and press monitor dial to store setting.

Press back button to return to previous screen.

Press home button to return to default screen.

OUT4001,000072D -19-31AUG15-1/1

## Cold Weather Start Aid

**CAUTION:** Ether is highly flammable. Do not use ether when starting an engine equipped with glow plugs.

**IMPORTANT:** Prevent possible damage to the engine. The diesel fired coolant heater is required for temperatures  $-20^{\circ}\text{C}$  ( $-4^{\circ}\text{F}$ ) and below. See an authorized John Deere dealer.

**IMPORTANT:** Prevent possible damage to engine. Temperatures below  $-20^{\circ}\text{C}$  ( $-4^{\circ}\text{F}$ ) require an additional warm-up period. See Cold Weather Warm-Up in this section.

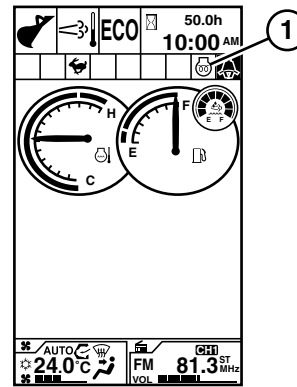

Engine Preheat Indicator

1— Engine Preheat Indicator

This machine is equipped with glow plugs. Glow plugs are automatically controlled by the engine controller when the key is turned ON. Do not start engine until the engine preheat indicator (1) disappears on the monitor.

KR46761.000123D -19-13JUL16-1/2

TX1219189 —UN—19JUL16

## Engine Block Heater—If Equipped

**CAUTION:** Prevent possible injury from electrical shock. Use grounded cord and inspect for damage before connecting to power source.

**IMPORTANT:** Prevent property damage as a result of possible fire from an overheated electrical cord. Use a heavy-duty, grounded cord to connect heater to electrical power.

Supply voltage for engine block heater is 120 V. Ensure correct supply voltage is used for engine block heater.

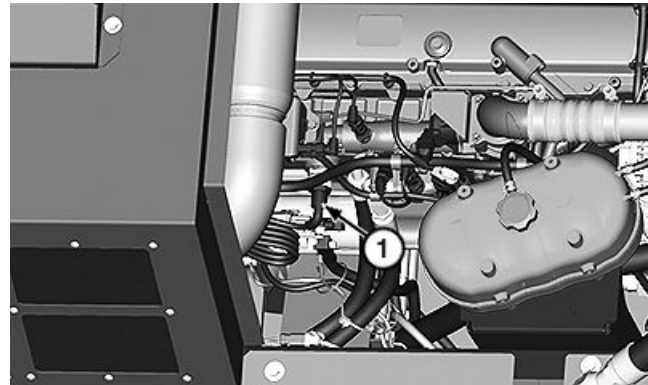

Engine Block Heater

1— Engine Block Heater

1. Open engine cover to access engine block heater (1).
2. Connect engine block heater to electrical power 10 hours before starting engine.
3. Close engine cover.

KR46761.000123D -19-13JUL16-2/2

TX1217763 —UN—17JUN16

During the cleaning process, the engine speed is controlled automatically and the machine must remain parked to complete the procedure. Complete cleaning time takes less than 45 minutes, but varies on several criteria including fuel type, oil type, duty cycle, ambient temperature, and the number of previously aborted exhaust filter cleaning requests. Exhaust combustion may temporarily emit white smoke during the cleaning process.

The cleaning process continues until one of the following conditions exist:

- An elapsed time of 45 minutes occurs, causing a time-out.
- Pilot shutoff lever is moved.
- Engine speed dial is moved.
- Parked cleaning is aborted due to a system fault.
- Engine runs out of fuel.
- Engine is shut off by operator (not recommended).

If any of these conditions happen during the parked cleaning process, the process is cancelled and a message is displayed on the monitor informing the operator. The condition needs to be amended and the parked cleaning

process must start over. For a system fault, see an authorized John Deere dealer.

**IMPORTANT: Avoid engine damage. If machine will NOT be returning to operation immediately after a parked cleaning procedure, allow the engine and exhaust filter time to return to normal operating temperatures BEFORE stopping engine.**

*NOTE: If machine needs to be operated during the parked cleaning procedure, press the exhaust filter parked cleaning switch again. The process is cancelled and a message is displayed on the monitor informing the operator. Machine operation can resume, but a parked cleaning must be performed as soon as possible.*

When there is no soot restriction in the exhaust filter, the parked cleaning procedure is complete. Engine automatically returns to slow idle and exhaust filter cleaning indicator turns off. A message appears on the monitor stating Exhaust Filter Cleaning Complete and the machine is ready to return to operation.

CN93077,000024D -19-30JUN16-2/2

Securing the Machine to Transport Equipment

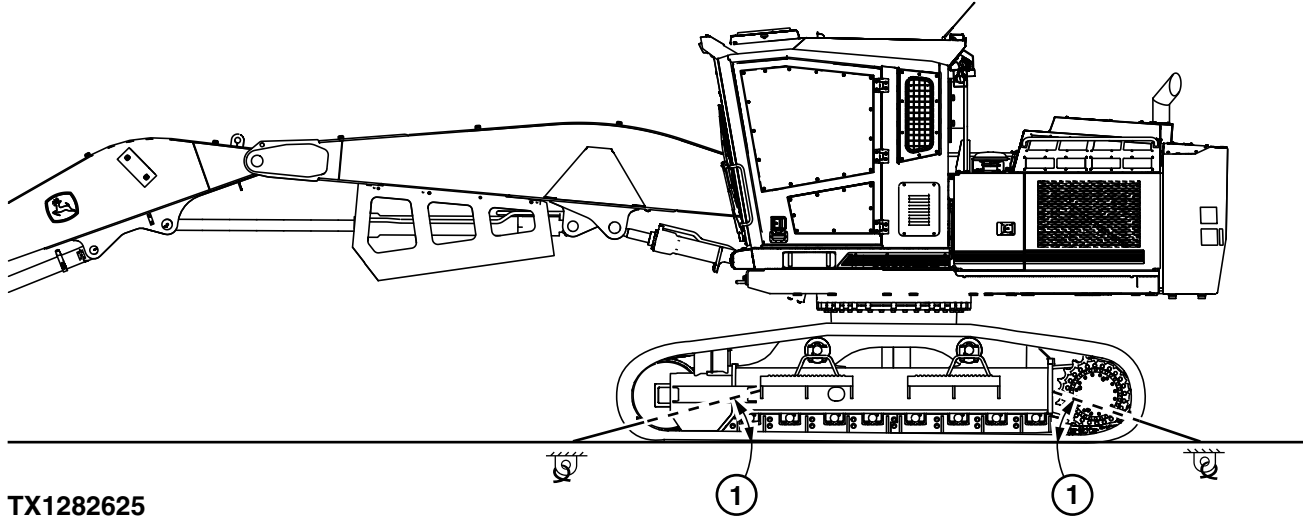

TX1282625

Machine (side entry cab, left side shown)

- 1—Vertical Tiedown Angle (4 used)  
 2—Side Tiedown Angle (4 used)

TD48962,00001CD -19-25OCT19-3/4

TX1282625—UN—01AUG19

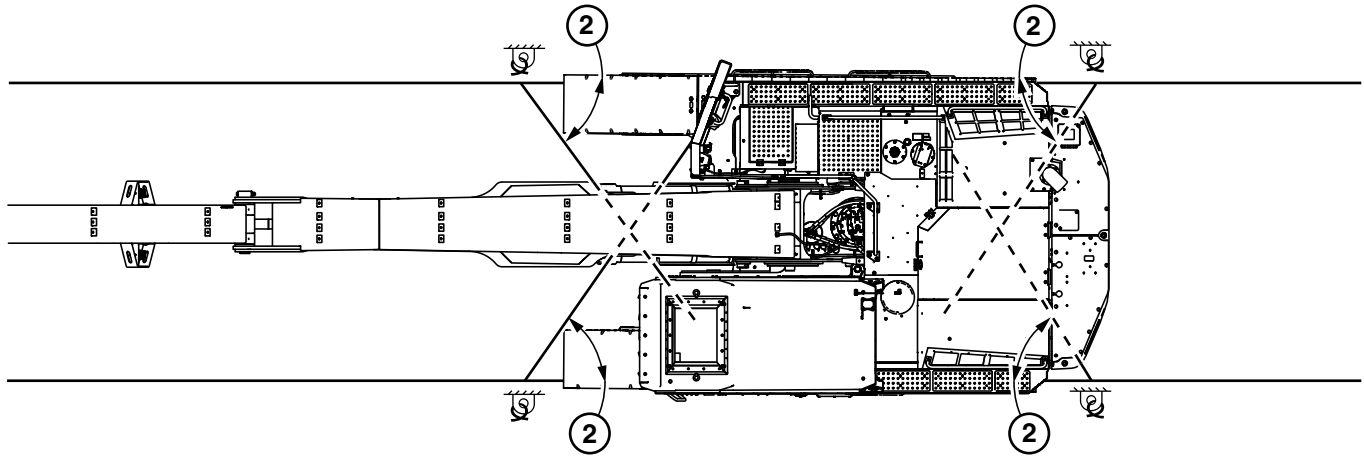

TX1282626

Machine (side entry cab, top of machine shown)

- 1—Vertical Tiedown Angle (4 used)  
 2—Side Tiedown Angle (4 used)

**IMPORTANT: Avoid machine damage. Fasten chains or cables to machine frame. Do not place chains or cables over or against hydraulic lines or hoses.**

1. Fasten machine to trailer using chains or cables with appropriate load binder at the following points:
  - Front frame tiedown point (2 used)

- Rear frame tiedown point (2 used)

Ensure vertical tiedown angles (1) and side tiedown angles (2) have angles between 15—60°.

2. Fasten all equipment to trailer using chains or cables with appropriate load binder.

TD48962,00001CD -19-25OCT19-4/4

TX1282626—UN—01AUG19

## Testing Diesel Exhaust Fluid (DEF)

**IMPORTANT: Using DEF with the correct concentration is critical to engine and aftertreatment system performance. Extended storage and other conditions can adversely alter the DEF concentration.**

If DEF quality is questionable, draw a sample out of the DEF tank or storage tank into a clear container. DEF must be crystal clear with a light ammonia smell. If DEF appears cloudy, has a colored tint, or has a profound ammonia smell, it is likely not within specification. DEF in this condition should not be used. Drain tank, flush with distilled water and refill with new or good DEF. After refilling the tank, check the DEF concentration.

If the DEF passes the visual and smell test, check the DEF concentration with a handheld refractometer calibrated to measure DEF.

DEF concentration should be checked when the engine has been stored for extended periods, or if there is

suspicion the engine or packaged DEF fluid has been contaminated with water.

Two approved tools are available through your John Deere dealer:

- JDG11594 Digital DEF Refractometer—A digital tool providing an easy to read concentration measurement
- JDG11684 DEF Refractometer—Low-cost alternative tool providing an analog reading

Follow instructions included with either tool to obtain the measurement.

The correct DEF concentration is 31.8—33.2% urea. If the DEF concentration is not within specification, drain the DEF tank, flush with distilled water and fill with new or good DEF. If packaged DEF is not within specification, dispose of DEF packages and replace with new or good DEF.

DX,DEF,TEST -19-13JUN13-1/1

## Storing Diesel Exhaust Fluid (DEF)

**CAUTION: Avoid contact with eyes. In case of contact, immediately flush eyes with large amounts of water for a minimum of 15 minutes. Reference the Materials Safety Data Sheet (MSDS) for additional information.**

**Do not ingest DEF. In the event DEF is ingested, contact a physician immediately. Reference the Materials Safety Data Sheet (MSDS) for additional information.**

**IMPORTANT: It is unlawful to tamper with or remove any component of the aftertreatment system. Do not use DEF that does not meet the required specifications or operate the engine with no DEF.**

**Never attempt to create DEF by mixing agricultural grade urea with water. Agricultural grade urea does not meet the necessary specifications and can damage the aftertreatment system.**

**Do not add any chemicals or additives to DEF in an effort to prevent freezing. Any chemicals or additives added to DEF can damage the aftertreatment system.**

**Never add water or any other fluid in place of, or in addition to DEF. Operating with a modified DEF or using an unapproved DEF can damage the aftertreatment system.**

Storage information provided below is for reference and is to be used as a guideline only.

It is preferred to store DEF out of extreme ambient temperatures. DEF freezes at  $-11^{\circ}\text{C}$  ( $12^{\circ}\text{F}$ ). Exposure to temperatures greater than  $30^{\circ}\text{C}$  ( $86^{\circ}\text{F}$ ) can degrade DEF over time. Do not store DEF in direct sunlight.

Dedicated DEF storage containers must be sealed between uses to prevent evaporation and contamination. Containers made of polyethylene, polypropylene, or stainless steel are recommended to transport and store DEF.

Ideal conditions for storage of DEF are:

- Store at temperatures between  $-5^{\circ}\text{C}$  and  $30^{\circ}\text{C}$  ( $23^{\circ}\text{F}$  and  $86^{\circ}\text{F}$ )
- Store in dedicated containers sealed to avoid contamination and evaporation

Under these conditions, DEF is expected to remain useable for a minimum of 18 months. Storing DEF at higher temperatures can reduce its useful life by approximately 6 months for every  $5^{\circ}\text{C}$  ( $9^{\circ}\text{F}$ ) temperature above  $30^{\circ}\text{C}$  ( $86^{\circ}\text{F}$ ).

If unsure how long or under what conditions DEF has been stored, test DEF. See Testing Diesel Exhaust Fluid (DEF).

Long-term storage in the DEF tank (over 12 months) is not recommended. If long-term storage is necessary, test DEF prior to operating engine. See Testing Diesel Exhaust Fluid (DEF).

It is recommended to purchase DEF in quantities that will be consumed within 12 months.

DX,DEF,STORE -19-15JUL20-1/1

CLICK HERE TO **DOWNLOAD** THE COMPLETE MANUAL

- Thank you very much for reading the preview of the manual.
- You can download the complete manual from: [www.heydownloads.com](http://www.heydownloads.com) by clicking the link below



- Please note: If there is no response to CLICKING the link, please download this PDF first and then click on it.

CLICK HERE TO **DOWNLOAD** THE COMPLETE MANUAL

## Water Quality for Mixing with Coolant Concentrate

Engine coolants are a combination of three chemical components: ethylene glycol (EG) or propylene glycol (PG) antifreeze, inhibiting coolant additives, and quality water.

Water quality is important to the performance of the cooling system. Deionized or demineralized water is recommended for mixing with ethylene glycol and propylene glycol base engine coolant concentrate.

All water used in the cooling system should meet the following minimum specifications for quality:

Chlorides	<40 mg/L
Sulfates	<100 mg/L
Total solids	<340 mg/L
Total dissolved hardness	<170 mg/L
pH	5.5—9.0

**IMPORTANT: Do not use bottled drinking water because it often contains higher concentrations of total dissolved solids.**

### Freeze Protection

The relative concentrations of glycol and water in the engine coolant determine its freeze protection limit.

Ethylene Glycol	Freeze Protection Limit
40%	-24°C (-12°F)
50%	-37°C (-34°F)
60%	-52°C (-62°F)
Propylene Glycol	Freeze Protection Limit
40%	-21°C (-6°F)
50%	-33°C (-27°F)
60%	-49°C (-56°F)

DO NOT use a coolant-water mixture greater than 60% ethylene glycol or 60% propylene glycol.

DX,COOL19 -19-13JAN18-1/1

## Operating in Warm Temperature Climates

John Deere engines are designed to operate using recommended engine coolants.

Always use a recommended engine coolant, even when operating in geographical areas where freeze protection is not required.

**IMPORTANT: Water may be used as coolant in emergency situations only.**

**Foaming, hot surface aluminum and iron corrosion, scaling, and cavitation occur when water is used as the coolant, even when coolant conditioners are added.**

**Drain cooling system and refill with recommended engine coolant as soon as possible.**

DX,COOL6 -19-17FEB20-1/1

## Required Parts

REQUIRED PARTS							
<b>Ensure machine performance and availability; use only genuine John Deere parts. Verify that part numbers are current and that any associated parts are also on hand, i.e., filter O-rings.</b>							
Description	Every 250 Hours	Every 500 Hours	Every 1000 Hours	Every 2000 Hours	Every 4000 Hours	Every 5000 Hours	Every 6000 Hours
Engine Oil Filter		1	1	1	1	1	1
Primary Fuel Filter Element		1	1	1	1	1	1
Final Fuel Filter Element		1	1	1	1	1	1
Auxiliary Fuel Filter Element (if equipped)		1	1	1	1	1	1
Hydraulic Tank Oil Filter Element			1	1	1	1	1
Pilot Oil Filter Element			1	1	1	1	1
Primary Air Filter Element			1	1	1	1	1
Secondary Air Filter Element			1	1	1	1	1
Dust Unloader Valve			1	1	1	1	1
Fuel Tank Breather			1	1	1	1	1
Engine Rocker Arm Cover Gasket				1	1		1
Open Crankcase Ventilation (OCV) Filter				1	1		1
Diesel Exhaust Fluid (DEF) Dosing Unit Filter <sup>5</sup>				1	1		1
Diesel Exhaust Fluid (DEF) Header Suction Filter and Baffle (kit) (S.N. —260155)					1		
Diesel Exhaust Fluid (DEF) Tank Breather Filter					1		
Diesel Exhaust Fluid (DEF) In-Line Filter <sup>5</sup> (S.N. 260156— )							1
Hydraulic Tank Cap Breather Element						1	
Cab Fresh Air Filter	As Required						
Cab Recirculating Air Filter	As Required						
Serpentine Belt	As Required						
Diesel Particulate Filter (DPF) (component of exhaust filter)	As Required						
High-Pressure Supply Filter (if equipped)	As Required						
Case Drain Filter (if equipped)	As Required						
John Deere Plus-50™ II Engine Oil <sup>3</sup>		19.5 L (5.2 gal)	20.5 L (5.4 gal)	20.5 L (5.4 gal)	20.5 L (5.4 gal)	20.5 L (5.4 gal)	20.5 L (5.4 gal)
API GL-5 Swing Gear Case Oil <sup>3</sup>			11.8 L (3.1 gal)	11.8 L (3.1 gal)	11.8 L (3.1 gal)	11.8 L (3.1 gal)	11.8 L (3.1 gal)
API GL-5 Travel Gear Case Oil <sup>3</sup>				17.0 L (4.4 gal)	17.0 L (4.4 gal)		17.0 L (4.4 gal)
John Deere Hydrau™ XR Hydraulic Oil <sup>1,3</sup>				147.6 L (39.0 gal)	147.6 L (39.0 gal)		147.6 L (39.0 gal)
John Deere Zinc-Free Hydraulic Oil 46 <sup>2,3</sup>						147.6 L (39.0 gal)	
John Deere Hydrau™ XR Cab Tilt Oil <sup>3</sup> —Rear Entry Cab Only						3.3 L (3.4 qt)	
John Deere Cool-Gard™ II Pre-Mix							23.0 L (6.1 gal)
<b>Fluid Analysis Kits<sup>4</sup></b>							

Continued on next page

KR46761,00011DA -19-13JUL22-1/2

## Clean Auxiliary Hydraulic Cooler Screen—If Equipped

**CAUTION:** Clear area of bystanders and wear personal protection equipment, including eye protection. Reduce compressed air to less than 196 kPa (1.96 bar) (28.4 psi) when using for cleaning purposes.

1. Remove cap screws (1) and lift auxiliary hydraulic cooler screen (2) to remove.
2. Attach an air wand to an air compressor and blow out dirt and debris from auxiliary hydraulic cooler screen.
3. Install auxiliary hydraulic cooler screen and cap screws.

1— Cap Screw (4 used)

2— Auxiliary Hydraulic Cooler Screen

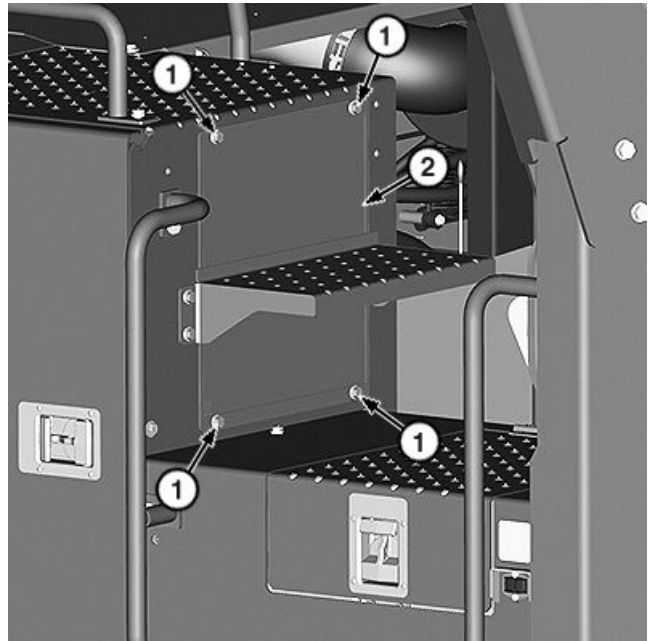

TX1217630 —UN—15JUN16

Auxiliary Hydraulic Cooler Screen

KR46761,000122E -19-26JUL16-1/1

## Lubricate Door Hinges

Lubricate all door hinge grease fittings until grease escapes at joints. See Track Adjuster, Working Tool Pivot, Swing Bearing, and Swing Bearing Gear Grease. (Section 3-1.)

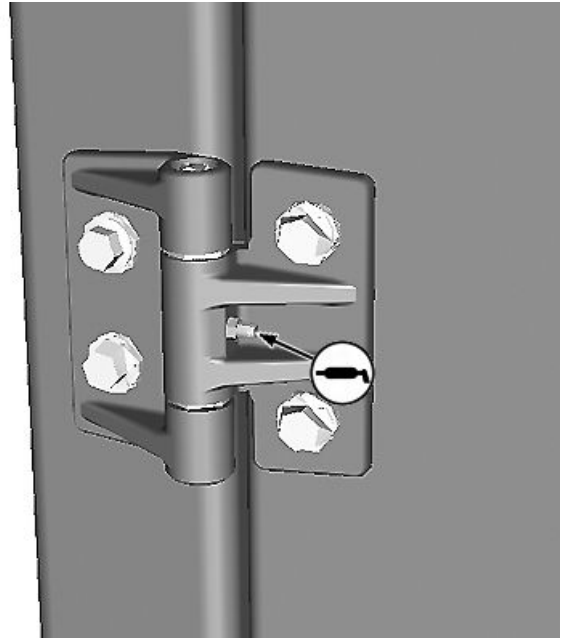

TX1216139 —UN—23MAY16

Door Hinge Grease Fitting

KR46761,0001168 -19-23MAY16-1/1

**Processor**

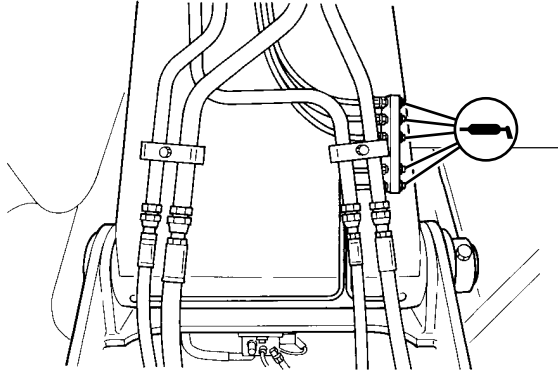

Five Points

TX1211144—UN—18FEB16

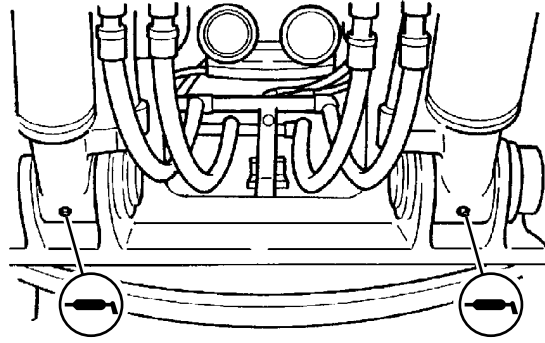

Two Points

TX1211151—UN—18FEB16

**NOTE:** See attachment manufacturer's manual for recommended service.

Lubricate front end pin joints (10 points) until grease escapes from joints. See Track Adjuster, Working Tool Pivot, Swing Bearing, and Swing Bearing Gear Grease. (Section 3-1.)

Lubricate every 4 hours for first 20 hours of operation, then every 10 hours thereafter.

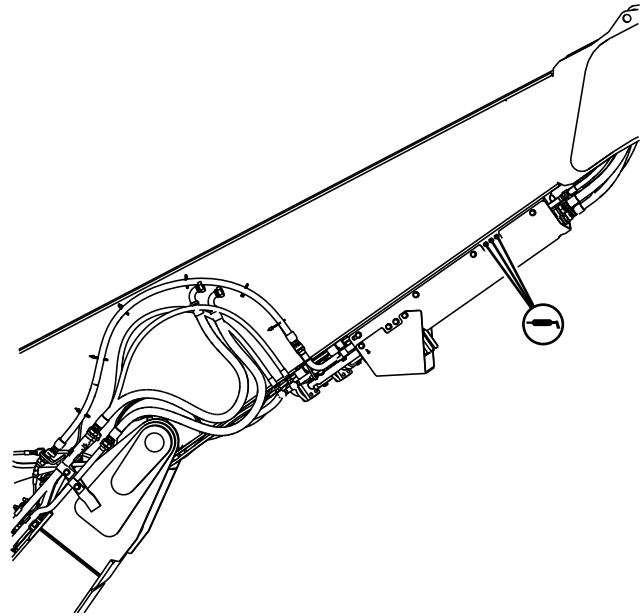

Three Points

TX1234098—UN—14FEB17

KR46761,0001233 -19-14FEB17-2/2

**IMPORTANT:** If water is added to batteries during freezing weather, batteries must be charged after water is added to prevent batteries from freezing. Charge battery using a battery charger or by running the engine.

2. Fill each cell to within the specified range with distilled water. DO NOT overfill.

**CAUTION:** Prevent possible injury. ALWAYS remove grounded (-) battery clamp first and replace it last.

3. Disconnect battery clamps, grounded clamp first.
4. Clean battery terminal (4) and clamps with a stiff brush.
5. Apply lubricating grease (5) around battery terminal base only.
6. Install and tighten clamps, grounded clamp last.

1— Battery Post  
2— Fill Tube  
3— Electrolyte Level Range

4— Battery Terminal  
5— Lubricating Grease

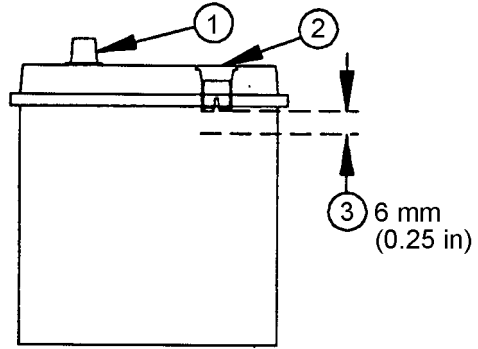

Battery Terminal and Fill Hole

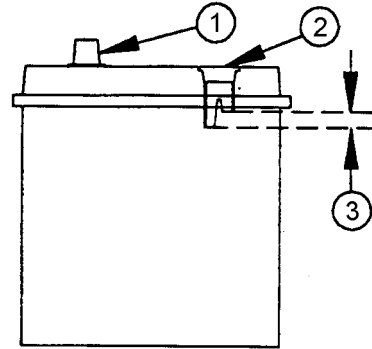

Fill Level

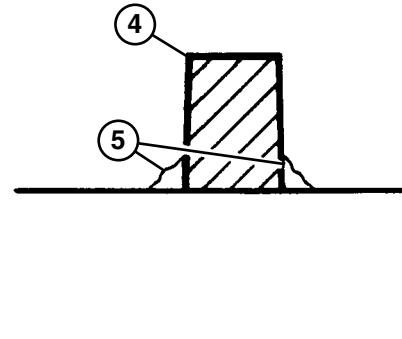

Terminal and Grease

TX1208617 —UN—05JAN16

T137636 —UN—25JAN01

TX1265575 —UN—03OCT18

TX, HYBATT, CHK -19-24APR20-2/2

## Replace Hydraulic Tank Oil Filter

1. Park and position machine with arm cylinder fully retracted and bucket cylinder (if equipped) fully extended.

**IMPORTANT:** Turbocharger can be damaged if procedure to shut down engine is not done properly.

2. Run engine at slow idle speed without load for 5 minutes.
3. Stop engine.
4. Insert 4 mm hex wrench (2) into hole (3) and turn counterclockwise to release locking pin.

**CAUTION:** Avoid personal injury from high-pressure fluid. High-pressure release of oil from pressurized system can cause serious burns or penetrating injury. Relieve pressure by slowly turning hydraulic tank cap (1) counterclockwise a few degrees.

To prevent possible burn injury from hot hydraulic oil, wait for hydraulic oil to cool before starting work.

5. Slowly turn hydraulic tank cap (1) counterclockwise a few degrees to relieve pressure.
6. Hold down hydraulic oil filter cover (6) against light spring load when removing the last two cap screws (7).

- |                       |                               |
|-----------------------|-------------------------------|
| 1— Hydraulic Tank Cap | 5— Aligning Mark (2 used)     |
| 2— Hex Wrench         | 6— Hydraulic Oil Filter Cover |
| 3— Hole               | 7— Cap Screw (6 used)         |
| 4— Case Assembly      |                               |

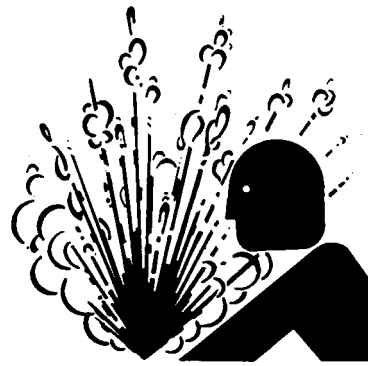

Pressurized Fluids

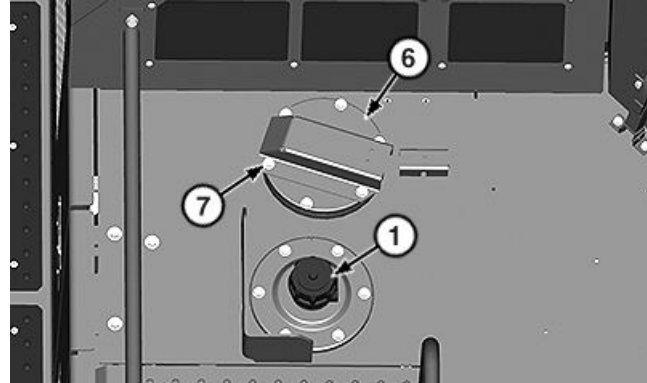

Hydraulic Tank

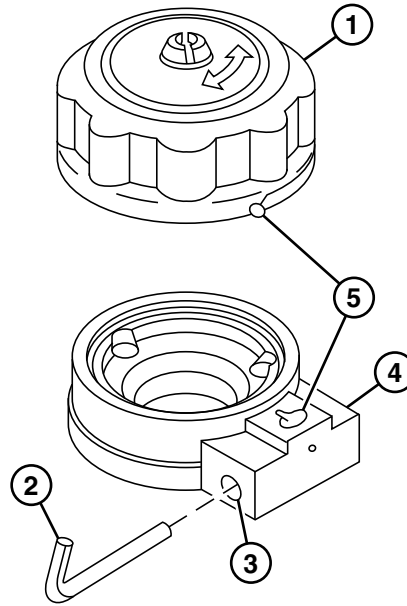

Hydraulic Tank Cap

Continued on next page

KR46761,0001253 -19-12JUL16-1/2

TS281 —UN—15APR13

TX1217874 —UN—21JUN16

TX1217692 —UN—22JUN16

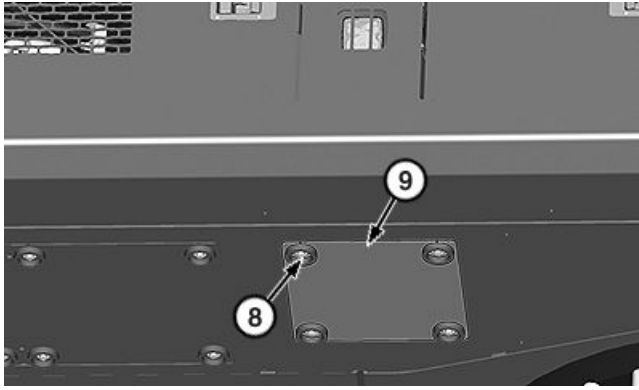

Access Cover (view from under machine)

TX1217987—UN—22JUN16

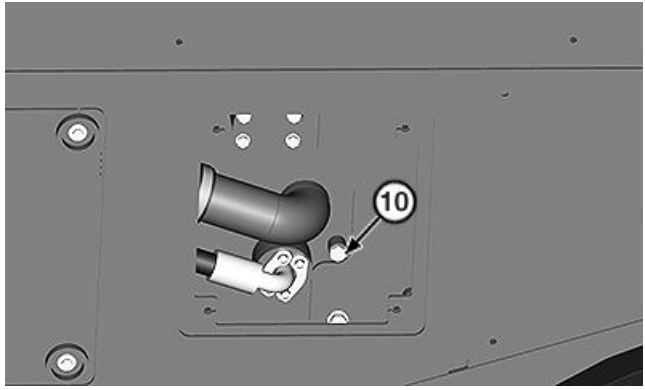

Drain Valve Cap Screw (view from under machine)

TX1217988—UN—22JUN16

8. Underneath right side of machine, remove cap screws (8) and access cover (9) to access drain valve cap screw (10).
9. Remove drain valve cap screw. Allow oil to drain into a container. Dispose of waste oil properly.
10. Install drain valve cap screw.
11. Remove suction screen from hydraulic tank cover. Clean inside of tank and suction screen.

**NOTE:** The hydraulic tank oil filter and pilot oil filter can be changed at this point in the procedure. See Maintenance—Every 1000 Hours. (Section 3-9.)

12. Install suction screen with hydraulic tank cover and cap screws. Suction screen must seal against outlet pipe in bottom of tank. Loosen suction screen rod nut (12) to adjust rod length if necessary.

**Specification**

Suction Screen Rod	
(11)—Length.....	869 mm (34 in)
Suction Screen Rod Nut	
(12)—Torque.....	15—20 N·m (133—177 lb-in)
Hydraulic Tank Cover	
Cap Screw—Torque.....	50 N·m (37 lb-ft)

**IMPORTANT: If the hydraulic pump is not filled with oil, it will be damaged when the engine is started.**

13. Add oil until it is between marks on sight glass. See Hydraulic Oil. (Section 3-1.)

**Specification**

Hydraulic Tank	
Oil—Capacity.....	147.6 L (39.0 gal)

14. Install hydraulic tank cap (1) to case assembly (4) using aligning marks (5) and turn cap clockwise to lock position.
15. Bleed air from hydraulic system. See Bleed Hydraulic System. (Section 4-1.)

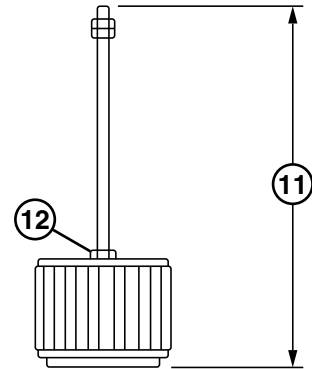

Suction Screen Assembly

TX1218002—UN—24JUN16

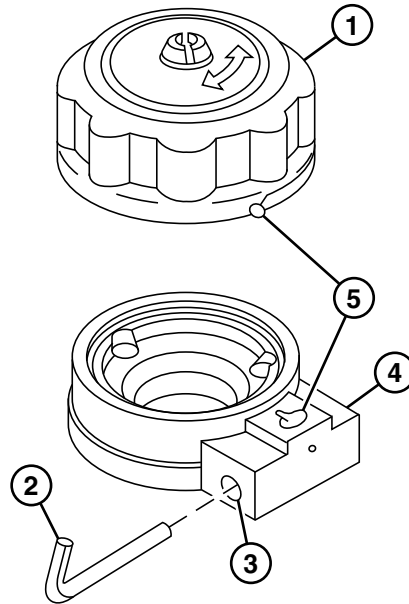

Hydraulic Tank Cap

TX1217692—UN—22JUN16

- |                          |                           |
|--------------------------|---------------------------|
| 1—Hydraulic Tank Cap     | 8—Cap Screw (4 used)      |
| 2—Hex Wrench             | 9—Access Cover            |
| 3—Hole                   | 10—Drain Valve Cap Screw  |
| 4—Case Assembly          | 11—Suction Screen Rod     |
| 5—Aligning Mark (2 used) | 12—Suction Screen Rod Nut |

# Maintenance—Every 6000 Hours

## Drain Cooling System



*Pressurized Fluids*

1. Open engine cover.
2. Check coolant hoses for cracks and leaks. Replace if necessary.
3. Check radiator, charge air, and oil cooler for dirt, grease, leaks, and loose or broken mountings. Clean radiator, charge air, and oil cooler fins. See Clean Radiator, Oil Cooler, Charge Air Cooler, and Fuel Cooler. (Section 4-1.)

**CAUTION:** Prevent possible injury from hot, spraying fluids. Shut off engine. Remove filler cap only when cool enough to touch with bare hands. Slowly loosen cap to relieve pressure before removing completely.

4. Remove surge tank cap (1) to relieve pressure.
5. Underneath left side of machine, remove cap screws (2) and access panel (3).

TS281 —UN—15APR13

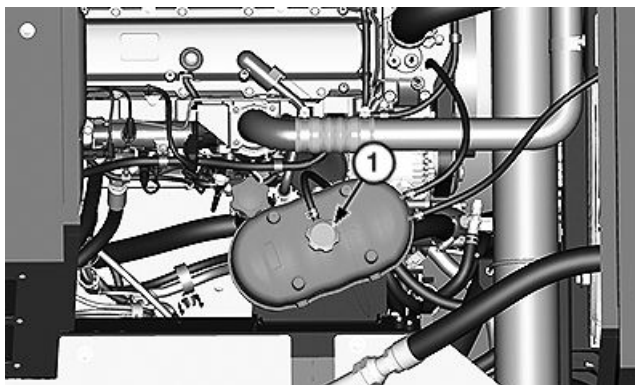

*Surge Tank Cap*

TX1218594 —UN—30JUN16

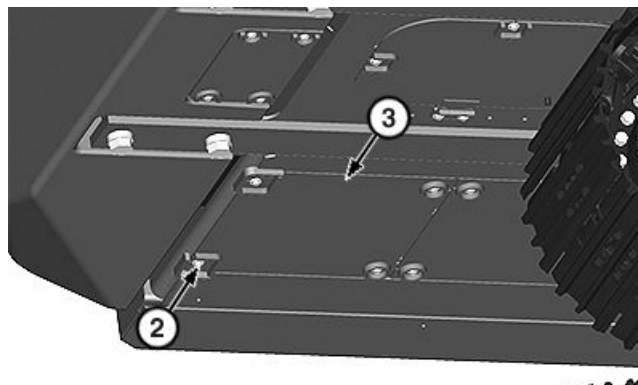

*Access Panel (view from under machine)*

TX1218589 —UN—30JUN16

1— Surge Tank Cap  
2— Cap Screw (4 used)

3— Access Panel

Continued on next page

KR46761.0001273 -19-16NOV16-1/2

### Check Windshield Washer Fluid Level—If Equipped

1. Open left rear service door to access windshield washer fluid bottle (1).

*NOTE: All-season windshield washer fluid is recommended during the winter season.*

2. Check fluid level in windshield washer fluid bottle and refill as required.
3. Close service door.

**1— Windshield Washer Fluid Bottle**

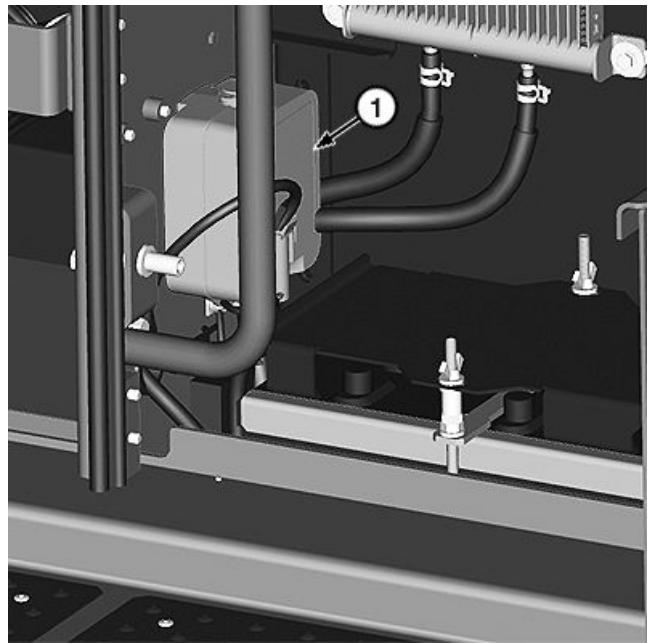

Windshield Washer Fluid Bottle

TX1218731 —UN—06JUL16

KR46761,0001277 -19-19DEC16-1/1

### JDLink™ In-Line Fuses—If Equipped

1. Turn off machine.
2. Open left front service door to access the JDLink™ unswitched power in-line 7.5 A fuse (F6001) on the red wire.
3. To deactivate the JDLink™ machine monitoring system, remove the JDLink™ unswitched power in-line 7.5 A fuse.
4. Close service door.

**F6001—JDLink™ Unswitched Power In-Line 7.5 A Fuse**

**F6003—JDLink™ Switched Power In-Line 7.5 A Fuse**

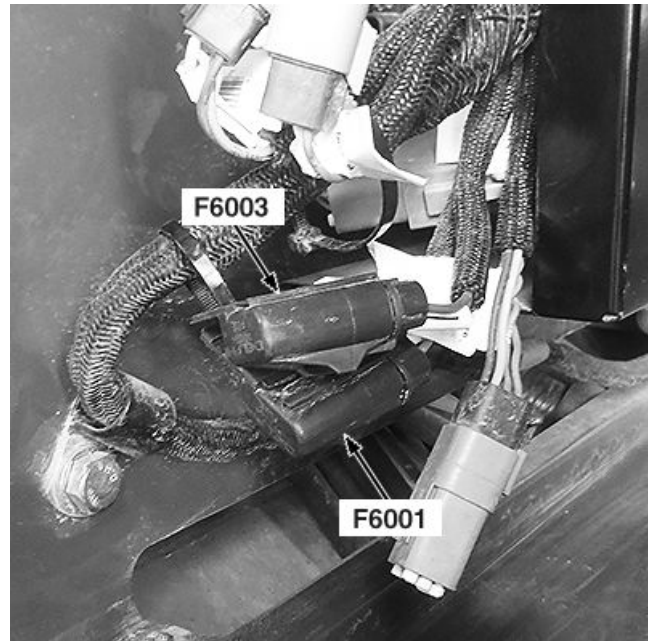

JDLink In-Line Fuses

TX1219211 —UN—13JUL16

JDLink is a trademark of Deere & Company

KR46761,00012B6 -19-10AUG18-2/2

### Fluid Sampling Test Ports—If Equipped

Open right rear service door to access engine oil sampling test port (1) and hydraulic oil sampling test port (2).

**1— Engine Oil Sampling Test Port**

**2— Hydraulic Oil Sampling Test Port**

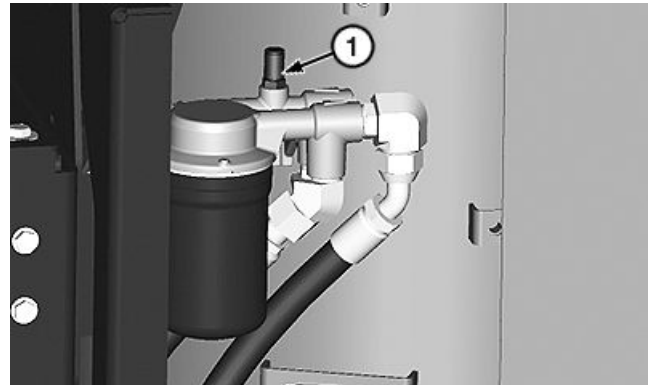

Engine Oil Sampling Test Port

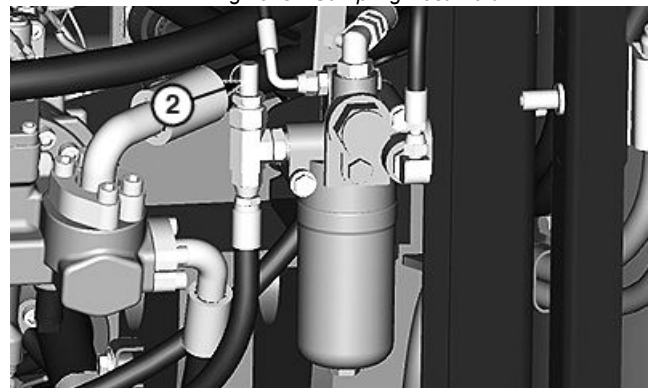

Hydraulic Oil Sampling Test Port

TX1218751 —UN—02AUG16

TX1220393 —UN—02AUG16

KR46761,000127B -19-02AUG16-1/1

**Horn Circuit Check**

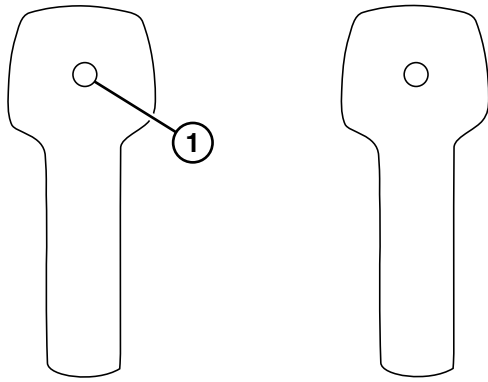

TX1213199 —UN—23MAR16  
Forestry Excavator or Forestry Excavator With Processor

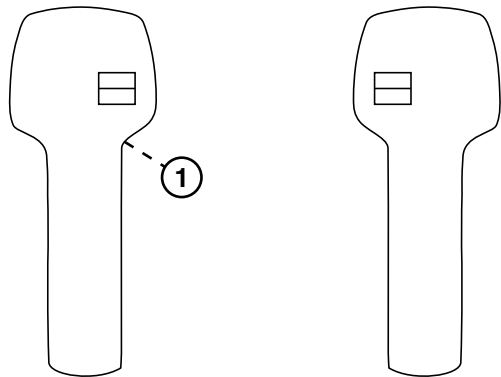

TX1213200 —UN—23MAR16  
Forestry Excavator With Thumb or Forestry Excavator With Power Clam

**NOTE:** Machines equipped with a processor do not include a horn button on the pilot control lever.

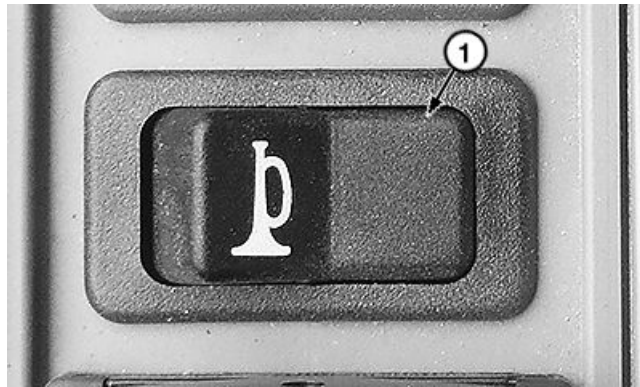

TX1213273 —UN—23MAR16  
Horn Switch (processor only)

- 1—Horn Button (forestry excavator)
- 1—Horn Button (forestry excavator with thumb or power clam)
- 1—Horn Switch (processor)

Key switch in OFF position.

Press horn button (1) located on left pilot control lever or horn switch (1) on the left console behind the left pilot control lever.

**LISTEN:** Does horn sound?

**YES:** Go to next check.

**NO:** Check horn 10 A fuse (marked HORN) (F19). See Replacing Fuses. (Section 4-1.)

IF OK: See an authorized John Deere dealer.

Continued on next page

KR46761,0001319 -19-01AUG18-5/51

**Windshield Wiper Control Check**

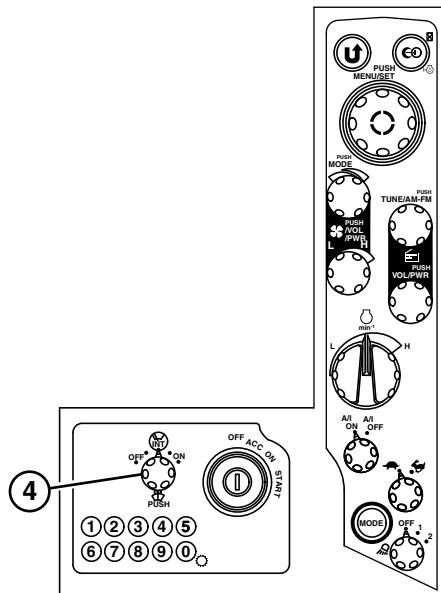

TX1086748 —UN—11JAN11

Switch Panel

**4— Windshield Wiper and Washer Switch**

Turn windshield wiper and washer switch (4) to first INT position.

*LOOK: Does wiper operate intermittently (8-second interval)?*

Turn windshield wiper and washer switch to second INT position.

*LOOK: Does wiper operate intermittently, but faster than when in first position (6-second interval)?*

Turn windshield wiper and washer switch to third INT position.

*LOOK: Does wiper operate intermittently, but faster than when in second position (3-second interval)?*

Turn windshield wiper and washer switch to ON position.

*LOOK: Does wiper operate continuously?*

Turn windshield wiper and washer switch to OFF position.

*LOOK: Does wiper arm stop and retract to left side of windshield?*

**YES:** Go to next check.

**NO:** Check windshield wiper and washer 20 A fuse (marked WIPER) (F2). See Replacing Fuses. (Section 4-1.)

IF OK: See an authorized John Deere dealer.

Continued on next page

KR46761,0001319 -19-01AUG18-16/51

Travel Alarm Check

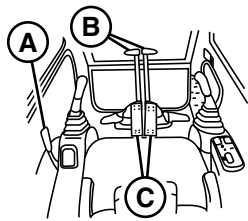

TX1095497 —UN—09AUG11

Travel Alarm

- A—Pilot Shutoff Lever
- B—Travel Lever and Pedal Forward
- C—Travel Lever and Pedal Rearward

**⚠ CAUTION: Avoid possible injury. Machine will move during this check. Make sure area is clear and large enough to operate machine.**

Place pilot shutoff lever (A) in unlocked (DOWN) position.

Push travel lever and pedal forward (B).

*LISTEN: Does travel alarm sound?*

Push travel lever and pedal rearward (C).

*LISTEN: Does travel alarm sound?*

**YES:** Go to next check.

**NO:** Check optional and attachment connector 5 A fuse (marked OPT. 1 ALT/SAW) (F5). See Replacing Fuses. (Section 4-1.)

IF OK: See an authorized John Deere dealer.

Continued on next page

KR46761,0001319 -19-01AUG18-27/51

**Dig Function Drift  
Check—Forestry  
Excavator Only**

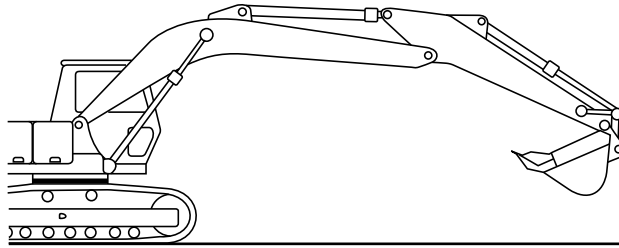

TX1095487 —UN—28JUN13

**Dig Function Drift Check—Forestry Excavator**

Fill the bucket with dirt to specification, if applicable.

**Specification**

Loaded Bucket—Weight (approximate)..... 1500 kg  
3307 lb

Position attachment at maximum reach with attachment pivot pin at same height as boom pivot pin.

Retract arm cylinder, then extend approximately 50 mm (2 in).

Extend attachment cylinder, then retract approximately 50 mm (2 in).

Measure distance from bottom of attachment to ground.

Stop engine.

Measure amount cylinders extend or retract in 5 minutes.

Compare measurements to specifications.

**Dig Function Drift—Specification**

Boom Cylinder—Drift.....	20 mm
	0.79 in
Arm Cylinder—Drift.....	30 mm
	1.18 in
Attachment Cylinder (if applica- ble)—Drift.....	20 mm
	0.79 in
Bottom of Attachment-to-Ground—Drift.....	150 mm
	5.91 in

*LOOK: Is cylinder drift within specification?*

**YES:** Go to next check.

**NO:** See an authorized John Deere dealer.

Continued on next page

KR46761,0001319 -19-01AUG18-37/51

Cycle Times Check

**CAUTION:** Prevent possible injury from unexpected machine movement. Clear all persons from the area before operating machine.

*NOTE:* For accurate cycle time reading, warm hydraulic oil to operating temperature.

*NOTE:* Cycle times are calculated with attachment removed.

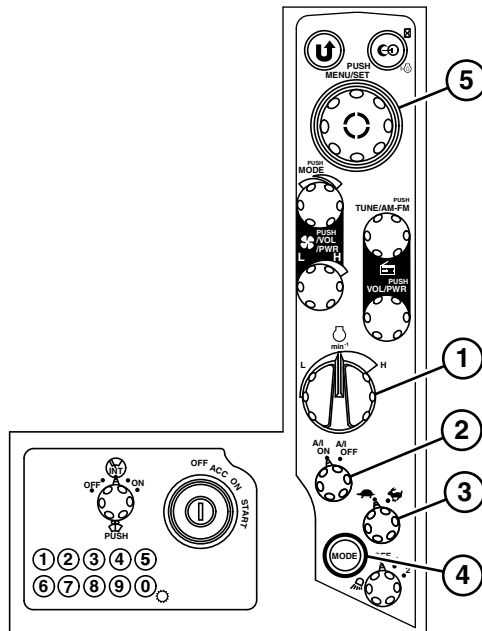

TX1136301 —UN—10MAY13

Switch Panel

- 1— Engine Speed Dial
- 2— Auto-Idle Switch
- 3— Travel Mode Switch
- 4— Power Mode Button
- 5— Monitor Dial

Turn engine speed dial (1) to H (fast idle) position.

Turn auto-idle switch (2) to A/I OFF position.

Press power mode button (4) until PWR (power) mode is displayed on monitor.

Symptom	Problem	Solution
<b>Engine Not Developing Full Power</b>	Air filters restricted or dirty	Replace air filter elements.
	Fuel filters restricted	Replace filters. Bleed air. Clean fuel tank inlet screen.
	Fuel filter not installed correctly	Install new filter and O-ring. Ensure proper O-ring seal. Bleed air.
	Contaminated fuel	Drain fuel tank. Change primary fuel filter and water separator. Bleed air. Add clean fuel.
	Incorrect fuel	Drain fuel tank and refill with correct fuel.
	Incorrect engine oil	Drain crankcase and refill with correct oil.
	Diesel exhaust fluid tank empty	Refill diesel exhaust fluid (DEF) tank. See Refilling Diesel Exhaust Fluid (DEF) Tank. (Section 3-1.)
	Exhaust filter restricted	See an authorized John Deere dealer.
	Incorrect valve clearance	See an authorized John Deere dealer.
	Worn engine	See an authorized John Deere dealer.
<b>Engine Oil Pressure Low</b>	Hydraulic issue	See an authorized John Deere dealer.
	Low crankcase oil level	Fill crankcase to proper oil level.
	Incorrect engine oil	Drain crankcase and refill with correct oil.
	Oil filter restricted	Replace oil filter.
	Oil leaks	Locate source of leak and repair as required.
	Excessive oil temperature	See an authorized John Deere dealer.
	Worn engine	See an authorized John Deere dealer.
<b>Engine Oil Pressure High</b>	Incorrect engine oil	Drain crankcase and refill with correct oil.

Continued on next page

KR46761,0000C35 -19-10JUL18-4/5

## Preparing Engine for Long-Term Storage

**IMPORTANT:** Any time the engine is not used for over 6 months, the following recommendations for storing and removing the engine from storage helps to minimize corrosion and deterioration.

**IMPORTANT:** Long-term storage is not advised when using biodiesel. For storage longer than 1 year, use straight hydrocarbon fuel.

If biodiesel must be used, it is recommended the blend not exceed B7 and a high-quality fuel stabilizer be used. Storage should not exceed 1 year.

For more information, see **BioDiesel Fuel.** (Section 3-1.)

*NOTE: The following storage preparations are used for long-term engine storage up to 1 year. After that, the engine should be started, warmed up, and retreated for an extended storage period.*

1. Change engine oil and replace filter. Used oil does not give adequate protection. Add 30 mL of rust preventive oil to the engine crankcase for every 1 L of engine oil, or 1 oz of rust preventative oil per 1 qt of engine oil. This rust preventive oil should be a SAE 10 oil with 1%—4% morpholine or equivalent vapor corrosion inhibitor such as NOX RUST VCI-10 OIL from Daubert Chemical Company, Inc.
  2. Replace air cleaner.
  3. Draining and flushing of cooling system is not necessary if the engine is only stored for less than 1 year. However, for extended storage periods of 1 year or longer, the recommendation is that the cooling system be drained, flushed, and refilled. Refill with appropriate coolant. See Diesel Engine Coolant (engine with wet sleeve cylinder liners). (Section 3-1.)
  4. Prepare a solution of diesel fuel and rust preventive oil in a temporary container, add 78 mL of rust preventive oil per 1 L of diesel fuel (10 oz of rust preventive oil per 1 gal of diesel fuel).
  5. Remove existing lines and plugs as required. Run a temporary line from the temporary container to the engine fuel intake located before the fuel filters. Run another temporary line from the fuel return to the temporary container. This set up allows rust preventive oil solution to circulate through the injection system during cranking.
- IMPORTANT:** Prevent possible damage to starter. Do not operate starter more than 30 seconds at a time. Wait at least 2 minutes for starter to cool before trying again.
6. Crank the engine several revolutions with starter. Do not allow the engine to start. Cranking the engine without starting allows rust preventive oil solution to circulate.
 

See an authorized John Deere dealer for the proper procedure.
  7. Remove temporary lines installed in step 5 and replace any lines or plugs previously removed.
  8. Loosen (or remove) and store fan and alternator poly-vee belt.
  9. Remove and clean batteries. Store them in a cool, dry place and keep them fully charged.
  10. Disengage the clutch for any driveline.
  11. For extended storage periods of 1 year or longer, drain or siphon diesel exhaust fluid (DEF) from DEF tank (if equipped).
  12. Clean the exterior of the engine with salt-free water and touch up any scratched or chipped painted surfaces with a high-quality paint.
  13. Coat all exposed bare metal surfaces with grease or corrosion inhibitor if not feasible to paint.
  14. Seal all openings on engine with plastic bags and tape.
  15. Store the engine in a dry, protected place. If engine must be stored outside, cover it with a waterproof canvas or other suitable protective material and use a strong, waterproof tape.

TX,PREP,ENG,STOR2 -19-23JUN20-1/1

Miscellaneous—Specifications

Item	Measurement	Specification
Rear Entry Cab With Forward Riser and Heavy Counterweight 2654GLC	Operating Weight (approximate)	34 560 kg 76 192 lb
Side Entry Cab	Operating Weight (approximate)	34 062 kg 75 094 lb
Rear Entry Cab	Operating Weight (approximate)	34 734 kg 76 575 lb
Rear Entry Cab With Forward Riser	Operating Weight (approximate)	34 801 kg 76 723 lb
Side Entry Cab With Heavy Counterweight	Operating Weight (approximate)	34 611 kg 76 304 lb
Rear Entry Cab With Heavy Counterweight	Operating Weight (approximate)	35 283 kg 77 786 lb
Rear Entry Cab With Forward Riser and Heavy Counterweight	Operating Weight (approximate)	35 350 kg 77 933 lb

KR46761,00012A4 -19-20DEC22-4/4

\* Hydraulically Limited Capacities

KR46761,00012A0 -19-16DEC16-2/2

	Page		Page
Testing.....	3-1-8	Display unit	
Use in SCR equipped engines.....	3-1-6	Software update menu.....	2-3-18
DEF (S.N. —260155)		Door	
Baffle		Access.....	3-2-3
Replace.....	3-11-1	Enclosure.....	3-2-3
Suction filter		Hinges	
Replace.....	3-11-1	Lubricate.....	3-3-9
Tank		Service.....	3-2-3
Clean.....	3-11-1	Drain and refill capacities	
DEF (S.N. 260156—)		Specifications.....	4-6-2
In-line filter		Driving	
Replace.....	3-13-4	Slopes.....	2-3-20
DEF dosing unit filter		Dust unloader valve	
Access.....	3-10-4	Engine air cleaner	
Replace.....	3-10-5	Replace.....	3-9-9
DEF tank breather filter			
Replace.....	3-11-2	<b>E</b>	
Diagnose malfunctions		E (economy) mode	
Troubleshooting procedure.....	4-3-1	Operational check.....	4-2-19
Diagnostic trouble code check		EAC Marking.....	1-2-1
Operational check.....	4-2-1	Effect of cold weather on diesel engines.....	3-1-5
Dial		Electrical	
Engine speed.....	2-1-1	System.....	4-1-13
Function.....	2-1-2	Electrical accessory	
Monitor.....	2-1-1	Adding.....	4-1-11
Function.....	2-1-2	Electrical system	
Diesel engine oil		Troubleshooting.....	4-3-10
Interim tier 4, final tier 4, stage IIIB, stage		Emission system	
IV, and stage V.....	3-1-11	Certification label.....	-11
Service interval for operation at high altitude.....	3-1-12	Emissions	
Diesel engines, cold weather effect.....	3-1-5	Required language	
Diesel exhaust fluid (DEF)		EPA.....	3-1-1
Indicator.....	2-2-1	Emissions Performance	
Function.....	2-2-2	Tampering.....	-21
Diesel exhaust fluid (DEF) (S.N. 260156—)		Enclosure	
In-line filter		Door.....	3-2-3
Replace.....	3-13-4	Engine	
Diesel exhaust fluid (DEF)(S.N. —260155)		Air intake hose	
Baffle		Check.....	3-8-5
Replace.....	3-11-1	Break-in.....	2-3-3
Tank		Cold weather warm-up.....	2-3-6
Clean.....	3-11-1	Coolant	
Suction filter		Check.....	3-4-2
Replace.....	3-11-1	Deaeration.....	3-13-3
Diesel fuel.....	3-1-1	Drain.....	3-13-1
Specifications.....	3-1-2	Fill.....	3-13-3
Supplemental additives.....	3-1-4	Test.....	3-9-10
Diesel fuel specifications.....	3-1-2	Cover.....	3-2-4
Diesel fuel, testing.....	3-1-4	Oil	
Dig function drift		Check.....	3-4-1
Operational check.....	4-2-32	Drain and refill.....	3-8-6
Display		Oil filter	
Air conditioner.....	2-2-1	Replace.....	3-8-6
Function.....	2-2-2	Specifications.....	4-6-1
Radio.....	2-2-1	Starting.....	2-3-4
Function.....	2-2-2	Troubleshooting.....	4-3-2
Display and clear trouble codes			
Operational check.....	4-2-1		

Continued on next page

CLICK HERE TO **DOWNLOAD** THE COMPLETE MANUAL

- Thank you very much for reading the preview of the manual.
- You can download the complete manual from: [www.heydownloads.com](http://www.heydownloads.com) by clicking the link below



- Please note: If there is no response to CLICKING the link, please download this PDF first and then click on it.

CLICK HERE TO **DOWNLOAD** THE COMPLETE MANUAL