

250GLC Excavator

(PIN: 1FF250GX_ _F608713—)



OPERATOR'S MANUAL 250GLC Excavator (PIN: 1FF250GX_ _F608713—) OMT351369X19 ISSUE D2 (ENGLISH)

CALIFORNIA
Proposition 65 Warning

Diesel engine exhaust and some of its constituents are known to the State of California to cause cancer, birth defects, and other reproductive harm.

If this product contains a gasoline engine:

⚠ WARNING

The engine exhaust from this product contains chemicals known to the State of California to cause cancer, birth defects or other reproductive harm.

The State of California requires the above two warnings.

Additional Proposition 65 Warnings can be found in this manual.

**Worldwide Construction
And Forestry Division**
PRINTED IN U.S.A.

CLICK HERE TO **DOWNLOAD** THE COMPLETE MANUAL

- Thank you very much for reading the preview of the manual.
- You can download the complete manual from: www.heydownloads.com by clicking the link below



- Please note: If there is no response to CLICKING the link, please download this PDF first and then click on it.

CLICK HERE TO **DOWNLOAD** THE COMPLETE MANUAL



JOHN DEERE

**U.S. AND CANADA EMISSION CONTROL WARRANTY STATEMENT
YOUR WARRANTY RIGHTS AND OBLIGATIONS**

To determine if the John Deere engine qualifies for the additional warranties set forth below, look for the "Emissions Control Information" label located on the engine. If the engine is operated in the United States or Canada and the Emissions Control information label states: "This engine complies with US EPA regulations for nonroad and stationary diesel engines", or "This engine conforms to US EPA nonroad compression-ignition regulations", refer to the "U.S. and Canada Emission Control Warranty Statement." If the engine is operated in California, and the label states: "This engine complies with US EPA and CARB regulations for nonroad diesel engines", or "This engine conforms to US EPA and California nonroad compression-ignition emission regulations", also refer to the "California Emission Control Warranty Statement."

Warranties stated on this certificate refer only to emissions-related parts and components of your engine. The complete engine warranty, less emissions-related parts and components, is provided separately. If you have any questions about your warranty rights and responsibilities, you should contact John Deere at 1-319-292-5400.

JOHN DEERE'S WARRANTY RESPONSIBILITY

John Deere warrants to the ultimate purchaser and each subsequent purchaser that this off-road diesel engine including all parts of its emission-control system was designed, built and equipped so as to conform at the time of the sale with Section 213 of the Clean Air Act and is free from defects in materials and workmanship which would cause the engine to fail to conform with applicable US EPA regulations for a period of five years from the date the engine is placed into service or 3,000 hours of operation, whichever first occurs.

Where a warrantable condition exists, John Deere will repair or replace, as it elects, any part or component with a defect in materials or workmanship that would increase the engine's emissions of any regulated pollutant within the stated warranty period at no cost to you, including expenses related to diagnosing and repairing or replacing emission-related parts. Warranty coverage is subject to the limitations and exclusions set forth herein. Emission-related components include engine parts developed to control emissions related to the following:

- | | |
|-----------------------------------|---------------------------------|
| Air-Induction System | Aftertreatment Devices |
| Fuel System | Crankcase Ventilation Valves |
| Ignition System | Sensors |
| Exhaust Gas Recirculation Systems | Engine Electronic Control Units |

EMISSION WARRANTY EXCLUSIONS

John Deere may deny warranty claims for malfunctions or failures caused by:

- Non-performance of maintenance requirements listed in the Operator's Manual
- The use of the engine/equipment in a manner for which it was not designed
- Abuse, neglect, improper maintenance or unapproved modifications or alterations
- Accidents for which it does not have responsibility or by acts of God

The off-road diesel engine is designed to operate on diesel fuel as specified in the Fuels, Lubricants and Coolants section in the Operators Manual. Use of any other fuel can harm the emissions control system of the engine/equipment and is not approved for use.

To the extent permitted by law John Deere is not liable for damage to other engine components caused by a failure of an emission-related part, unless otherwise covered by standard warranty.

THIS WARRANTY IS EXPRESSLY IN LIEU OF ANY OTHER WARRANTIES, EXPRESS OR IMPLIED, INCLUDING ANY WARRANTY OF MERCHANTABILITY OR FITNESS FOR A PARTICULAR PURPOSE. REMEDIES UNDER THIS WARRANTY ARE LIMITED TO THE PROVISIONS OF MATERIAL AND SERVICES AS SPECIFIED HEREIN. WHERE PERMITTED BY LAW, NEITHER JOHN DEERE NOR ANY AUTHORIZED JOHN DEERE ENGINE DISTRIBUTOR, DEALER, OR REPAIR FACILITY OR ANY COMPANY AFFILIATED WITH JOHN DEERE WILL BE LIABLE FOR INCIDENTAL OR CONSEQUENTIAL DAMAGES.

Emission_CI_EPA (18Dec09)

DX,EMISSIONS,EPA -19-12DEC12-2/2

TS1721 -JUN-15JUL13

FCC Notifications to User

FCC Notification

These devices comply with Part 15 of the FCC Rules. Operation is subject to the following two conditions: (1) These devices may not cause harmful interference, and (2) these devices must accept any interference received, including interference that may cause undesired operation.

These devices must be operated as supplied by John Deere Ag Management Solutions. Any changes or modifications made to these devices without the express written approval of John Deere Ag Management Solutions may void the user's authority to operate these devices.

Modular Telematics Gateway and Satellite Module

This equipment has been tested and found to comply with the limits for Class B digital devices, pursuant to part 15 of the FCC Rules. These limits are designed to provide reasonable protection against harmful interference in a

residential installation. This equipment generates, uses, and can radiate radio frequency energy, and if not installed and used in accordance with the instructions, may cause harmful interference to radio communications. However, no guarantee shall be made that interference will not occur in a particular installation. If this equipment does cause harmful interference to radio or television reception, which can be determined by turning the equipment off and on, the user is encouraged to try to correct the interference by one or more of the following measures:

- Reorient or relocate the receiving antenna.
- Increase the separation between the equipment and receiver.
- Connect the equipment into an outlet on a circuit different from that to which the receiver is connected.
- Consult the dealer or an experienced radio/TV technician for help.

MM16284.000196F -19-20FEB19-1/1

	Page
Lift Capacity—Arm: 2.50 m (8 ft. 2 in.); Bucket: 851 kg (1876 lb.); Shoe 600 mm (28 in.).....	4-6-6
Lift Capacity—Arm: 2.50 m (8 ft. 2 in.); Bucket: 851 kg (1876 lb.); Shoe 700 mm (28 in.).....	4-6-7
Lift Capacity—Arm: 2.50 m (8 ft. 2 in.); Bucket: 851 kg (1876 lb.); Shoe 800 mm (32 in.).....	4-6-8
Lift Capacity—Arm: 2.96 m (9 ft. 9 in.); Bucket: 871 kg (1920 lb.); Shoe: 700 mm (28 in.).....	4-6-9
Lift Capacity—Arm: 2.96 m (9 ft. 9 in.); Bucket: 871 kg (1920 lb.); Shoe: 800 mm (32 in.).....	4-6-10
Lift Capacity—Arm: 3.61 m (11 ft. 10 in.); Bucket: 871 kg (1920 lb.); Shoe: 700 mm (28 in.).....	4-6-11
Lift Capacity—Arm: 3.61 m (11 ft. 10 in.); Bucket: 871 kg (1920 lb.); Shoe: 800 mm (32 in.).....	4-6-12

Decommissioning — Proper Recycling and Disposal of Fluids and Components

Safety and environmental stewardship measures must be taken into account when decommissioning a machine and/or component. These measures include the following:

- Use appropriate tools and personal protective equipment such as clothing, gloves, face shields or glasses, during the removal or handling of objects and materials.
- Follow instructions for specialized components.
- Release stored energy by lowering suspended machine elements, relaxing springs, disconnecting the battery or other electrical power, and releasing pressure in hydraulic components, accumulators, and other similar systems.
- Minimize exposure to components which may have residue from agricultural chemicals, such as fertilizers and pesticides. Handle and dispose of these components appropriately.
- Carefully drain engines, fuel tanks, radiators, hydraulic cylinders, reservoirs, and lines before recycling components. Use leak-proof containers when draining fluids. Do not use food or beverage containers.
- Do not pour waste fluids onto the ground, down a drain, or into any water source.
- Observe all national, state, and local laws, regulations, or ordinances governing the handling or disposal of waste fluids (example: oil, fuel, coolant, brake fluid);

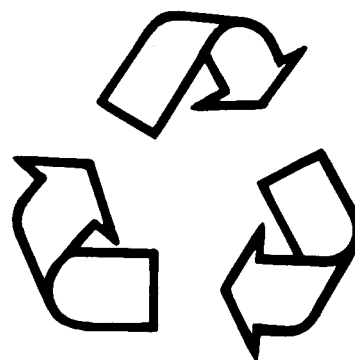

TS1133 —UN—15APR13

- filters; batteries; and, other substances or parts. Burning of flammable fluids or components in other than specially designed incinerators may be prohibited by law and could result in exposure to harmful fumes or ashes.
- Service and dispose of air conditioning systems appropriately. Government regulations may require a certified service center to recover and recycle air conditioning refrigerants which could damage the atmosphere if allowed to escape.
 - Evaluate recycling options for tires, metal, plastic, glass, rubber, and electronic components which may be recyclable, in part or completely.
 - Contact your local environmental or recycling center, or your John Deere dealer for information on the proper way to recycle or dispose of waste.

DX,DRAIN -19-01JUN15-1/1

Exhaust Filter Ash Handling and Disposal

CAUTION: Under federal, state, and local laws or regulations, exhaust filter ash can be classified as a hazardous waste. Hazardous waste must be disposed of in accordance with all applicable federal, state, and local laws or regulations governing hazardous waste disposal. Only a

qualified service provider should remove ash from the exhaust filter. Personal protective equipment and clothing, maintained in a sanitary and reliable condition, should be used when handling and cleaning exhaust filter. See an authorized John Deere dealer for exhaust filter ash handling and disposal.

TX,ASH,DISP -19-31MAR22-1/1

Prepare for Emergencies

Be prepared if a fire starts.

Keep a first aid kit and fire extinguisher handy.

Keep emergency numbers for doctors, ambulance service, hospital, and fire department near your telephone.

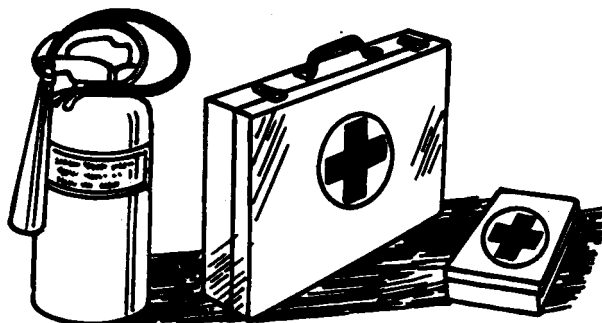

TS291 —UN—15APR13

DX,FIRE2 -19-03MAR93-1/1

Service Cooling System Safely

Explosive release of fluids from pressurized cooling system can cause serious burns.

Do not service radiator through the radiator cap. Only fill through the surge tank filler cap. Shut off engine. Only remove surge tank filler cap when cool enough to touch with bare hands. Slowly loosen cap to relieve pressure before removing completely.

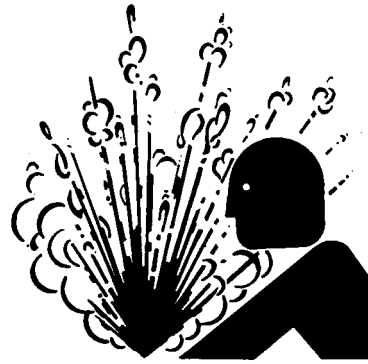

TS281—UN—15APR13

TX,SURGE -19-19JAN11-1/1

Remove Paint Before Welding or Heating

Avoid potentially toxic fumes and dust.

Hazardous fumes can be generated when paint is heated by welding, soldering, or using a torch.

Remove paint before heating:

- Remove paint a minimum of 100 mm (4 in.) from area to be affected by heating. If paint cannot be removed, wear an approved respirator before heating or welding.
- If you sand or grind paint, avoid breathing the dust. Wear an approved respirator.
- If you use solvent or paint stripper, remove stripper with soap and water before welding. Remove solvent or paint stripper containers and other flammable material from area. Allow fumes to disperse at least 15 minutes before welding or heating.

Do not use a chlorinated solvent in areas where welding will take place.

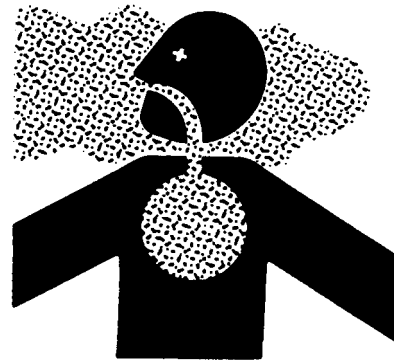

TS220—UN—15APR13

Do all work in an area that is well ventilated to carry toxic fumes and dust away.

Dispose of paint and solvent properly.

DX,PAINT -19-24JUL02-1/1

Make Welding Repairs Safely

IMPORTANT: Disable electrical power before welding. Turn off main battery switch and disconnect positive (+) and negative (-) battery cables.

Do not weld or apply heat on any part of a reservoir or tank that has contained oil or fuel. Heat from welding and cutting can cause oil, fuel, or cleaning solution to create gases which are explosive, flammable, or toxic.

Avoid welding or heating near pressurized fluid lines. Flammable spray may result and cause severe burns if pressurized lines malfunction as a result of heating. Do not let heat go beyond work area to nearby pressurized lines.

Remove paint properly. Do not inhale paint dust or fumes. Use a qualified welding technician for structural repairs.



Heating Near Pressurized Fluid Lines

T133547—UN—15APR13

Make sure there is good ventilation. Wear eye protection and protective equipment when welding.

TX,WELD,SAFE -19-08MAY20-1/1

Safety Signs Installed on Hydraulic Coupler—If Equipped

⚠ WARNING



CLEARANCE HAZARD!
COUPLER MOUNTED AND SOME DIRECT MOUNTED ATTACHMENTS COULD POSSIBLY CONTACT CAB OR BOOM. MAINTAIN CLEARANCE BETWEEN ATTACHMENT, CAB AND BOOM.

A57967

⚠ WARNING



CRUSH HAZARD!
Improperly locked attachment could release and cause death or serious injury. Do not operate attachment when supplemental lock is primary locking device.

- Release supplemental lock by going to full curl before picking up attachment.
- Engage supplemental lock by pressing LOCK button on control box and extending bucket cylinder and holding until locking plate wedges under attachment pin, then uncurl bucket.

Make sure locking plate is right under attachment pin.
Supplemental lock must be engaged before using coupler.

A58270A

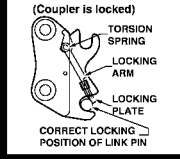

⚠ WARNING



CRUSH HAZARD!
GROUND TEST REQUIRED!
BEFORE USING THE ATTACHMENT, PERFORM A GROUND TEST TO VERIFY IT IS PROPERLY LOCKED TO THE COUPLER. PLACE ATTACHMENT FLAT ON THE GROUND. WHILE APPLYING SLIGHT DOWN PRESSURE, TRY TO UNCURL THE ATTACHMENT. THE ATTACHMENT SHOULD STAY IN TIGHT CONTACT WITH THE COUPLER WITH LITTLE OR NO MOVEMENT.









A57965

⚠ WARNING

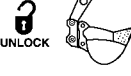

CRUSH HAZARD!
Attachment could drop without warning if not properly attached. Read owner's manual for proper installation procedures.

TO LOCK COUPLER	TO UNLOCK COUPLER
<p>1. Engage front hook on pin</p> 	<p>1. Keep attachment close to ground</p> 
<p>2. Rotate to full-curl position. Push LOCK button. Hold in full-curl position for 5 seconds.</p> 	<p>2. Rotate coupler to full curl position to release supplemental lock</p> 
<p>3. Slowly uncurl coupler. Visually verify supplemental lock contacts locking plate. Visually verify lock plate is behind attachment pin.</p> 	<p>3. Push UNLOCK button and hold for two seconds. Hold coupler in full-curl position for 5 seconds.</p> 
<p>4. Continue to slowly uncurl coupler. Verify attachment is properly locked.</p> 	<p>4. Slowly uncurl coupler. Attachment will release from hooks.</p> 

A58273A

TX1105472

Hydraulic Coupler Safety Signs

TX.SIGNS,HYD,COUP -19-18MAY20-1/1

TX1105472—19—13JAN12

Service ADVISOR™ Remote (SAR) Switch

The Service ADVISOR™ Remote (SAR) switch (1) allows operator to accept or decline software updates available to the machine when prompted by an alarm on the monitor. LEDs on the SAR switch will illuminate when the alarm appears. The left LED will be red and the right LED will be green.

Press left side of SAR switch (red LED) to DECLINE installation (2) of software updates.

Press right side of SAR switch (green LED) to ACCEPT installation (3) of software updates.

For more information on SAR functionality, see Service ADVISOR™ Remote (SAR) Software Delivery Process and Service ADVISOR™ Remote (SAR) Operation. (Section 2-3.)

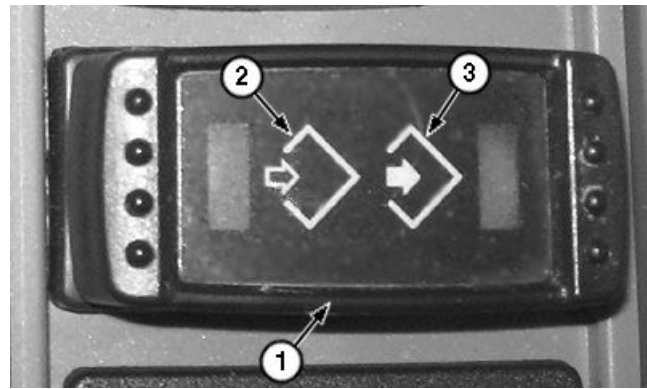

Service ADVISOR™ Remote Switch

1— Service ADVISOR™ Remote (SAR) Switch
2— DECLINE Installation

3— ACCEPT Installation

Service ADVISOR is a trademark of Deere & Company

OUT4001,0000748 -19-15MAY19-1/1

TX1086797A—UN—21JAN11

Auxiliary Function Enable Switch—If Equipped

(S.N. —610767)

The pilot control shutoff lever must be in the unlocked (DOWN) position to enable auxiliary function lever (AFL) functions. See Pilot Shutoff Lever. (Section 2-1.)

Press auxiliary function enable switch (1) to enable auxiliary function lever (AFL) on the right pilot control lever. The light-emitting diode (LED) on auxiliary function enable switch illuminates when functions are enabled.

NOTE: If pilot control lever is cycled to the locked (UP) position and then back to the unlocked (DOWN) position, the auxiliary function enable switch will be disabled.

To disable AFL, press the auxiliary function enable switch again or place the pilot control shutoff lever in the locked (UP) position. LED turns off when functions are disabled.

For more information, see Auxiliary Function Lever (AFL)—If Equipped. (Section 2-3.)

(S.N. 610768—)

The pilot control shutoff lever must be in the unlocked (DOWN) position to enable auxiliary function lever (AFL) functions. See Pilot Shutoff Lever. (Section 2-1.)

Press auxiliary function enable switch to enable auxiliary function lever (AFL) on the right pilot control lever. The



Auxiliary Function Enable Switch

1— Auxiliary Function Enable Switch

light-emitting diode (LED) on auxiliary function enable switch illuminates when functions are enabled.

NOTE: If pilot control lever is cycled to the locked (UP) position and then back to the unlocked (DOWN) position, the auxiliary function enable switch will remain enabled.

To disable AFL, press the auxiliary function enable switch again. LED turns off when functions are disabled.

For more information, see Auxiliary Function Lever (AFL)—If Equipped. (Section 2-3.)

TD48962,000005F -19-25JAN18-1/1

TX1168382A—UN—11AUG14

Adjusting the Air Suspension Seat—If Equipped

CAUTION: Prevent possibly injury. Do not adjust seat settings while operating the machine.

While sitting on seat, push down on seat angle lever (1) to adjust seat to desired angle. Release lever.

Pull up on seat fore-and-aft handle (2) to unlock seat. Slide seat to desired distance from pilot control levers. Release handle.

Pull out firmness button (3) to decrease seat firmness. With key switch in the ON position, press in and hold firmness button to increase seat firmness.

Pull up on backrest lever (4) to release backrest lock. Move backrest to desired position. Release lever.

Squeeze lumbar ball (5) to add air for firmness to lower backrest area. Press button on bottom of lumbar ball to release air and decrease firmness.

Pull headrest (6) upward or push downward to desired height. Move headrest to desired angle.

Pull up on armrest (7) to move it out of the way when exiting the cab.

Turn armrest dial (8) to adjust angle of armrest.

Pull seat and console handle (9) up toward operator. Slide entire seat and consoles to desired distance from travel pedals and levers. Release handle.

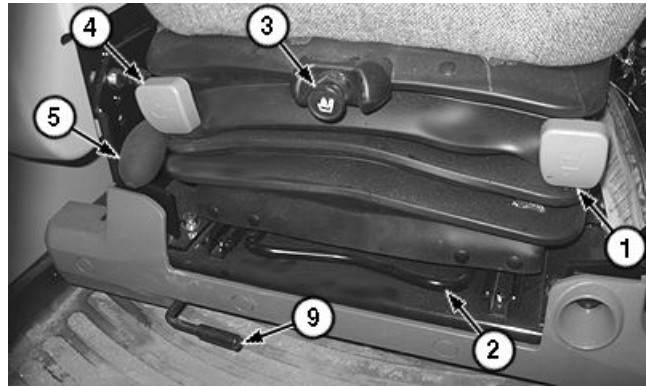

Air Suspension Seat

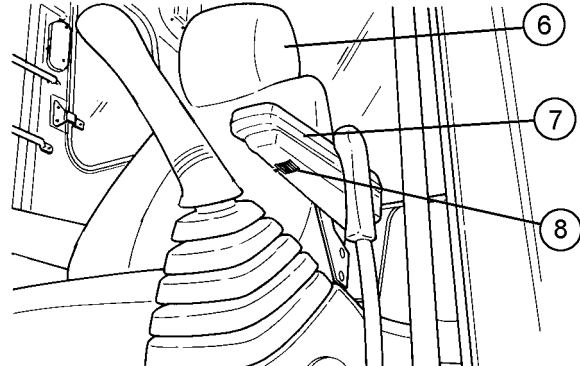

Adjusting the Armrest

- | | |
|-----------------------------|----------------------------|
| 1— Seat Angle Lever | 6— Headrest |
| 2— Seat Fore-and-Aft Handle | 7— Armrest |
| 3— Firmness Button | 8— Armrest Dial |
| 4— Backrest Lever | 9— Seat and Console Handle |
| 5— Lumbar Ball | |

TX1087310A—UN—25JAN11

T140133—UN—02MAY01

CN93077.000025C -19-11JAN17-1/1

Main Menu—Alarm List

The **Alarm List** menu will always appear as the first submenu under Main Menu, but **ONLY** if there is an actual alarm generated. If there is more than one alarm, a list will be displayed. If there are no alarms, Alarm List will not appear as a submenu.

The submenus under Main Menu that appear on monitor include:

NOTE: Alarm List ONLY appears as a submenu if there is an actual alarm.

- Alarm List
- Air Conditioner
- Radio
- Work Mode
- Setting Menu
- Information Menu

At Main Menu screen (1) with Alarm List highlighted, press monitor dial (2) to view generated alarms.

If there is more than one alarm, rotate monitor dial to highlight a particular alarm. Press monitor dial to view detailed information about that alarm and how to rectify the problem.

When an alarm indicator appears on the monitor display, an alarm light (5) is also illuminated on the bottom of the monitor to alert the operator.

Press back button (3) to return to previous screen.

Press home button (4) to return to default screen.

- | | |
|---------------------|----------------|
| 1— Main Menu Screen | 4— Home Button |
| 2— Monitor Dial | 5— Alarm Light |
| 3— Back Button | |

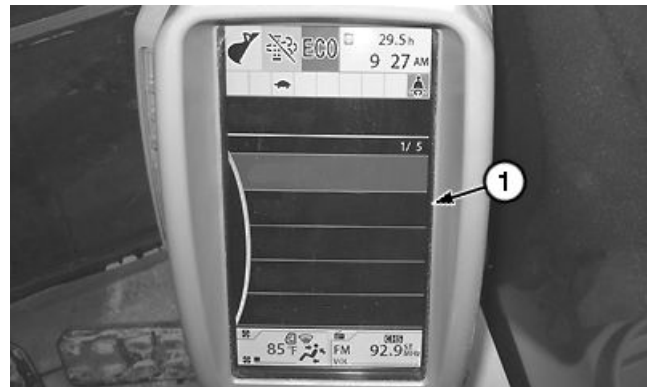

Main Menu Screen

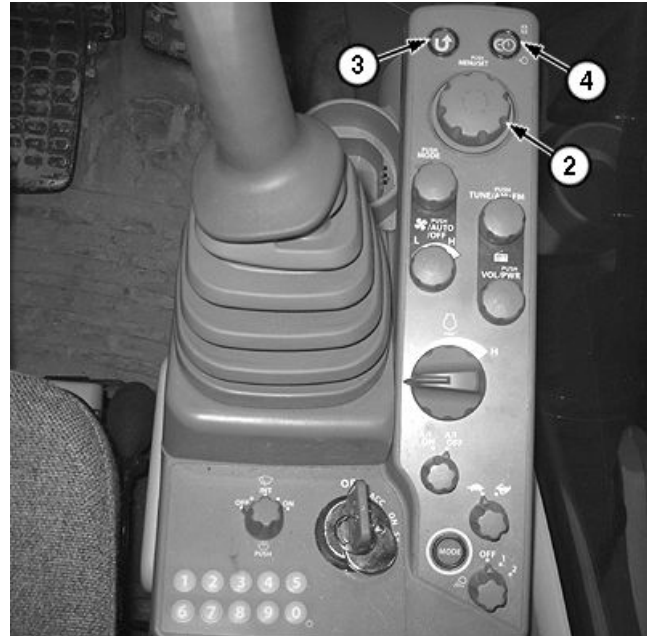

Switch Panel



Alarm Light

Continued on next page

CN93077,000023B -19-28JUL17-1/28

TX1086306A—UN—28DEC10

TX1086272A—UN—27DEC10

TX1160717A—UN—15MAY14

Main Menu—Work Mode

The **Work Mode** menu allows operator to select front attachment.

The submenus under Main Menu that appear on monitor include:

NOTE: Alarm List ONLY appears as a submenu if there is an actual alarm.

- Alarm List
- Air Conditioner
- Radio
- Work Mode
- Setting Menu
- Information Menu

At Main Menu screen (1), rotate monitor dial (2) to highlight Work Mode. Press monitor dial to display Work Mode menu.

Work Mode menu items include:

NOTE: This list of front attachments are examples only. Personalized list of front attachments can be entered in monitor through the Attachment Name Input screen. See Main Menu—Setting Menu—Attachment Name Input in this section.

- Bucket (bucket icon will also be shown)
- Thumb 1 (thumb icon will also be shown)
- Breaker 1 (breaker icon will also be shown)
Type-A
- Breaker 2 (breaker icon will also be shown)
Type-B
- Pulverizer 1 (pulverizer icon will also be shown)
- Crusher 1 (crusher icon will also be shown)
- Grapple 1 (grapple icon will also be shown)

Rotate monitor dial to highlight desired front attachment. Press monitor dial to select the desired attachment for operation.

If Bucket work mode was selected, screen will revert back to the default screen and a bucket icon displays on monitor in the upper left corner.

If any other work mode is selected, the following information is displayed:

- Maximum Pump Flow Rate.....XXX.XX gpm
- Maximum Engine Speed.....XXXX min⁻¹
- Selector Valve.....O/T or C/V
- 2 Pumps Combined Flow.....OFF/ON
- Breaker Relief Pressure.....OFF/ON
- ✓

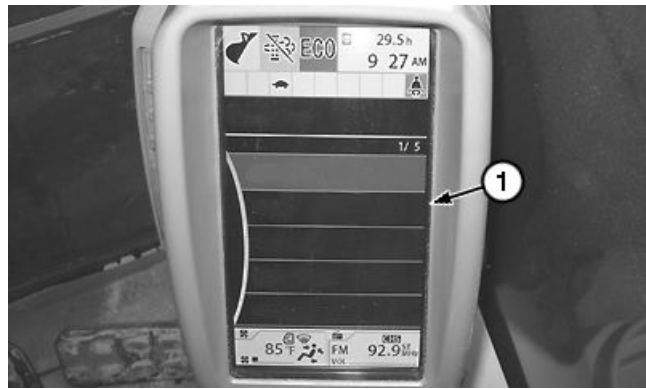

Main Menu Screen

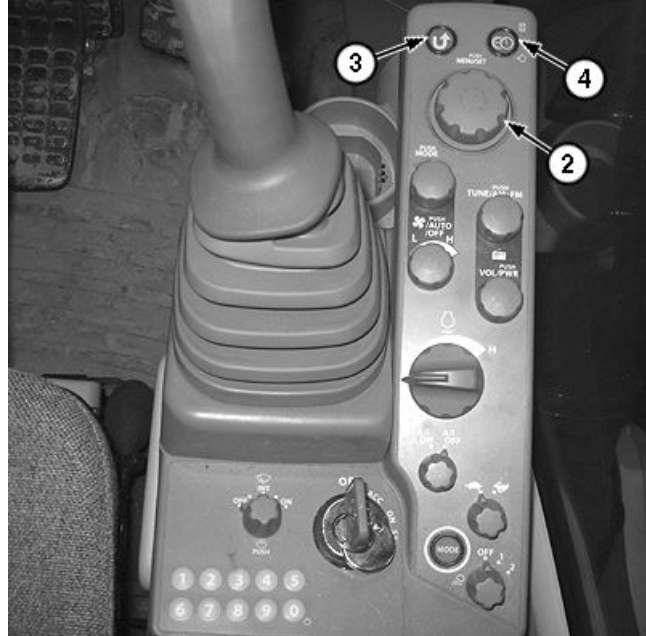

Switch Panel

1— Main Menu Screen
2— Monitor Dial

3— Back Button
4— Home Button

If adjustments need to be made to this information, see an authorized John Deere dealer. If information is correct and ready for operation, rotate monitor dial to highlight the checkmark (✓) and press monitor dial. Screen will revert back to the default screen and selected attachment icon displays on monitor in the upper left corner.

Press back button (3) to return to previous screen.

Press home button (4) to return to default screen.

OUT4001,0000720 -19-31AUG15-1/1

TX1086306A—UN—28DEC10

TX1086272A—UN—27DEC10

Main Menu—Information Menu—Operation

The **Operation** menu provides fuel consumption and operating hours of the breaker, front attachment, tracks, and overall machine hours.

At Information Menu, rotate monitor dial to highlight Operation. Press monitor dial to display Operation menu.

NOTE: Total fuel consumption and fuel consumption rate depend on the operating environment and the operation method of machine.

Operation menu items include:

• Fuel Consumption

Rotate monitor dial to highlight Fuel Consumption. Press monitor dial to display Fuel Consumption information:

- **Machine Operation Hours** **XX h**
- **Fuel Consumption** **XX L**
- **Average Fuel Consumption Rate**....**XX.X L/h**

Press monitor dial to return to the previous menu. To reset fuel consumption data, rotate monitor dial to highlight CLEAR in the bottom right corner of screen and press monitor dial.

• Breaker Operation

Rotate monitor dial to highlight Breaker Operation. Press monitor dial to display Breaker Operation information:

- **Operating Time****XXXXXX.X h**
- **Machine Operation Hours****XXXX.X h**
- **Operation Ratio**.....**XXX.X %**

Press monitor dial to return to the previous menu. To reset breaker operating data, rotate monitor dial to highlight CLEAR in the bottom right corner of screen and press monitor dial.

• Attachment Operation

Rotate monitor dial to highlight Attachment Operation. Press monitor dial to display Attachment Operation information:

- **Operating Time****XXXX.X h**

Press monitor dial to return to the previous menu.

To reset attachment operating hours, rotate monitor dial to highlight CLEAR in the bottom right corner of screen and press monitor dial.

• Travel Operation

Rotate monitor dial to highlight Travel Operation. Press monitor dial to display Travel Operation information:

- **Operating Time****XXXX.X h**

Press monitor dial to return to the previous menu. To

reset travel operating hours, rotate monitor dial to highlight CLEAR in the bottom right corner of screen and press monitor dial.

• Actual Operation

NOTE: The actual operation time includes the front attachment operation and the travel operation hours.

Rotate monitor dial to highlight Actual Operation. Press monitor dial to display Actual Operation information:

- **Operating Time****XXXX.X h**

Press monitor dial to return to the previous menu. To reset actual operating hours, rotate monitor dial to highlight CLEAR in the bottom right corner of screen and press monitor dial.

Press back button to return to previous screen.

Press home button to return to default screen.

Travel Pedals and Levers

CAUTION: Prevent possible injury from unexpected machine movement. Keep bystanders clear of machine when traveling.

Keep bystanders clear of machine when traveling.

IMPORTANT: Prevent unexpected machine movement. Note current position of the travel motors (4). If motors are to the front of the machine, the machine moves **OPPOSITE** to the travel direction described in the following instructions.

The following instructions apply when the travel motors (4) are to the rear of the machine. If the travel motors are to the front of the machine, the machine moves **OPPOSITE** to the direction described.

FORWARD TRAVEL (1): Push down on front of both pedals or press both levers forward.

REVERSE TRAVEL (2): Push down on rear of both pedals or pull both levers rearward.

NEUTRAL POSITION (3): Travel brakes automatically stop and hold the machine.

RIGHT TURN: Push down on front of left pedal or press left lever forward.

LEFT TURN: Push down on front of right pedal or press right lever forward.

SHORT TURN (COUNTER ROTATE): Push down the front of one pedal and the rear of the other or press one lever forward and pull the other rearward.

SINGLE PEDAL TRAVEL (5): If equipped, single pedal travel can be used to move machine in forward or reverse direction of travel only.

1. Disengage single pedal travel lock (6) by pushing forward.
2. **FORWARD TRAVEL:** Push down on front of single pedal travel.
3. **REVERSE TRAVEL:** Push down on rear of single pedal travel.
4. Engage single pedal travel lock by pulling back.

CAUTION: Prevent possible injury from machine tipping. Operate control pedals or levers slowly when traveling down a slope.

TRAVELING DOWN A SLOPE: Operate control pedals or levers slowly when traveling down a slope.

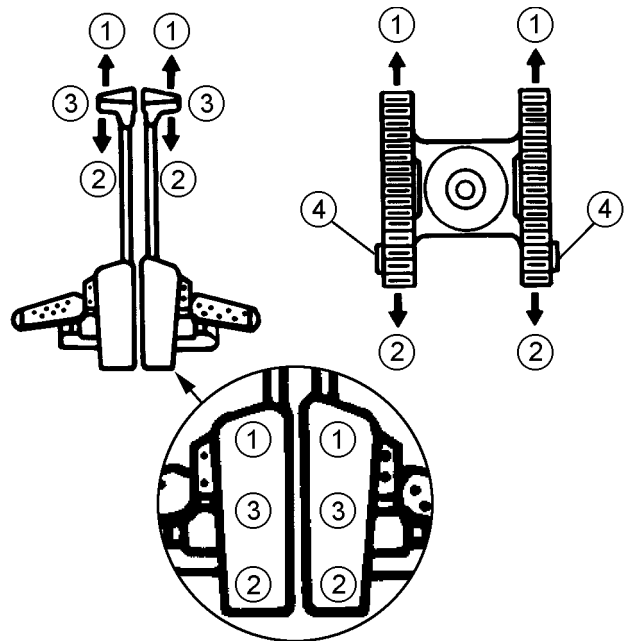

Travel Pedals and Levers

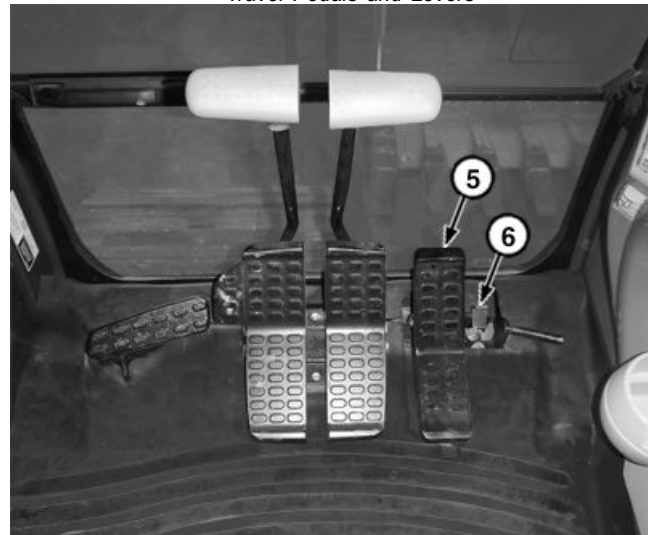

Single Pedal Travel

- | | |
|---------------------|-----------------------------|
| 1— Forward Travel | 4— Travel Motor (2 used) |
| 2— Reverse Travel | 5— Single Pedal Travel |
| 3— Neutral Position | 6— Single Pedal Travel Lock |

COLD WEATHER OPERATION: Travel pedal and lever dampers are provided for smooth control. In extreme cold weather, pedal or lever effort increases. Operate pedals or levers several times with pilot shutoff lever in the locked (UP) position.

TD48962,0000059 -19-30JAN18-1/1

T1137492 —UN—25JAN01

TX1250286A —UN—16JAN18

Service ADVISOR™ Remote (SAR) Operation

The flex power controller (FPC) will interface with JDLink™ and the monitor to communicate the availability of software updates and programming progress. The Service ADVISOR™ Remote (SAR) switch (1) is wired directly to the FPC and allows the operator to accept or decline available updates. Alarm indicators on the display are controlled through diagnostic trouble codes (DTCs) originating from the FPC. The FPC will create the DTCs under certain conditions, which will then prompt the monitor to display operator instructions. It will be necessary to interact with a John Deere dealer or technician for needed information.

NOTE: The programming alarm indicator is used for different purposes, but the color of the alarm indicator changes for each purpose.

When a software update is available to install, a yellow programming alarm will appear on the monitor, along with a message stating:

SOFTWARE UPDATE READY

NOTE: Alarm List ONLY appears as a submenu if there is an actual alarm.

The Alarm List submenu under the Main Menu will give instructions to guide the operator through the process. For viewing alarm instructions, see Main Menu—Alarm List. (Section 2-2.)

Park machine and stop engine. Installation of the software can only process if the engine is not running and pilot shutoff lever is in locked (UP) position.

NOTE: Before installing software, make sure the **SOFTWARE TERMS AND CONDITIONS** have been read. Find **SOFTWARE TERMS AND CONDITIONS** at the beginning of this manual.

LEDs on the SAR switch will illuminate when this alarm appears. The left LED will be red and the right LED will be green.

Press and hold the right side of SAR switch (green LED) for 3 seconds to begin programming installation. Press left side of SAR switch (red LED) to cancel software update and wait until the next power cycle.

*JDLink is a trademark of Deere & Company
Service ADVISOR is a trademark of Deere & Company*

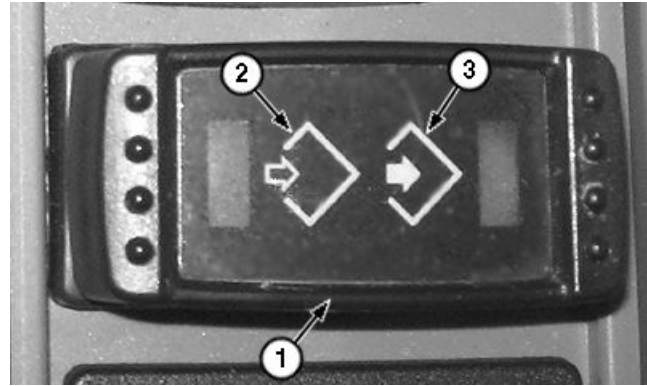

Service ADVISOR™ Remote Switch
TX1087187 —UN—21JAN11



Programming Alarm

- | | |
|---|----------------------------|
| 1— Service ADVISOR™ Remote (SAR) Switch | 3— ACCEPT Software Updates |
| 2— DECLINE Software Updates | |

If operator chooses to install the new update, the programming alarm will remain on the monitor, but the color will change to red and the message will state:

PROGRAMMING IN PROCESS

Green LED on SAR switch will blink while programming is taking place.

DO NOT turn OFF machine power until the programming is complete.

Once programming is completed, programming alarm will turn green and the message will state:

PROGRAMMING COMPLETED

Cycle machine power to complete the installation process.

Continued on next page

TX,SAR,OPERATION,1 -19-13JUL20-1/3

TX1086797A —UN—21JAN11

Engine stop indicator illuminates when a condition exists which requires immediate operator action and service.

RG22493 —UN—21AUG13

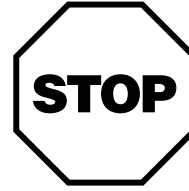

Engine Stop Indicator

TX,MACH,STOP,WARNING -19-23JUN20-3/6

Emission System Fault Has Occurred

RG26361 —UN—04SEP14

Four hours or less remaining, engine emissions system malfunction and warning indicators are illuminated to warn operator of emissions-related fault. Two hours or less when pop-up is displayed.

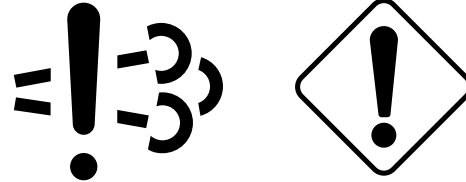

Engine Emissions System Malfunction and Warning Indicators

- Engine power is normal.
- Machine operation is normal.
- Place machine in a safe state.
- Contact service provider.

TX,MACH,STOP,WARNING -19-23JUN20-4/6

Sixty minutes remaining, engine emissions system malfunction and engine stop indicators are illuminated and alarm sounds to warn operator of emissions-related fault. Sixty minutes or less from when pop-up is displayed until final power restriction.

RG26972 —UN—26MAR15

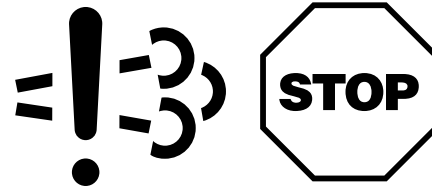

Engine Emissions System Malfunction and Engine Stop Indicators

- Engine power and torque will be reduced.
- Key Off—Key On will temporarily provide full power.
- Place machine in a safe state.
- Contact service provider.

TX,MACH,STOP,WARNING -19-23JUN20-5/6

Two minutes or less remaining, engine emissions system malfunction and engine stop indicators are illuminated and alarm sounds to warn operator of emissions-related fault which has not been corrected. “DEF System Fault-Engine Power and Speed Limited” is displayed on machines with monitors.

RG26972 —UN—26MAR15

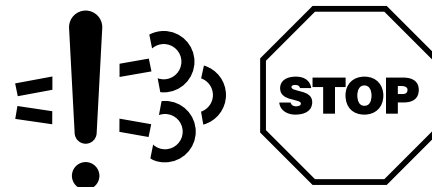

Engine Emissions System Malfunction and Engine Stop Indicators

- Engine power is idle only.
- Place machine in a safe state.
- Contact service provider.

TX,MACH,STOP,WARNING -19-23JUN20-6/6

Maintenance—Machine

Required Emission-Related Information

Service Provider

A qualified repair shop or person of the owner's choosing may maintain, replace, or repair emission control devices and systems with original or equivalent replacement parts. However, warranty, recall, and all other services paid for by John Deere must be performed at an authorized John Deere service center.

DX,EMISSIONS,REQINFO -19-12JUN15-1/1

Diesel Fuel

Consult a local fuel distributor for properties of the diesel fuel available in the area.

In general, diesel fuels are blended to satisfy the low temperature requirements of the geographical area in which they are marketed.

Diesel fuels specified to EN 590 or ASTM D975 are recommended. Renewable diesel fuel produced by hydrotreating animal fats and vegetable oils is basically identical to petroleum diesel fuel. Renewable diesel fuel that meets EN 590 or ASTM D975 is acceptable for use at all percentage mixture levels.

Required Fuel Properties

In all cases, the fuel shall meet the following properties:

Cetane number of 43 minimum. Cetane number greater than 47 is preferred, especially for temperatures below -20°C (-4°F) or elevations above 1500 m (5000 ft).

Cloud Point should be below the expected lowest ambient temperature or **Cold filter plugging point** (CFPP) should be at least 5°C (9°F) below the expected lowest temperature or **Cloud Point** below the expected lowest ambient temperature.

Fuel lubricity should pass a maximum scar diameter of 0.52 mm as measured by ASTM D6079 or ISO 12156-1. A maximum scar diameter of 0.45 mm is preferred.

Diesel fuel quality and sulfur content must comply with all existing emissions regulations for the area in which the engine operates. DO NOT use diesel fuel with sulfur content greater than 10 000 mg/kg (10 000 ppm).

E-Diesel fuel

 **CAUTION: Avoid severe injury or death due to the fire and explosion risk from using E-Diesel fuel.**

DO NOT use E-Diesel (Diesel fuel and ethanol blend).

Use of E-Diesel fuel in any John Deere machine may void the machine warranty.

Sulfur Content for Engines That Meet Interim Tier 4, Final Tier 4, Stage III B, Stage IV, and Stage V Engines

- Use ONLY ultra low sulfur diesel (ULSD) fuel with a maximum of 15 mg/kg (15 ppm) sulfur content.

Use of fuel other than ULSD will reduce the efficiency and durability of the engine, will harm and permanently damage the engine's advanced emissions control systems, reduce fuel economy, and possibly prevent the engine from running at all. Emission-related warranties are likely to be rendered void by the use of fuel that does not meet these specifications.

Sulfur Content for Engines That Meet Tier 3 and Stage III A Engines

- Use of diesel fuel with sulfur content less than 2000 mg/kg (2000 ppm) is RECOMMENDED.
- Use of diesel fuel with sulfur content 2000—5000 mg/kg (2000—5000 ppm) REDUCES the oil and filter change interval.
- BEFORE using diesel fuel with sulfur content greater than 5000 mg/kg (5000 ppm), contact an authorized John Deere dealer.

Sulfur Content for Engines That Meet Tier 2 and Stage II Engines

- Use of diesel fuel with sulfur content less than 2000 mg/kg (2000 ppm) is RECOMMENDED.
- Use of diesel fuel with sulfur content 2000—5000 mg/kg (2000—5000 ppm) REDUCES the oil and filter change interval.
- BEFORE using diesel fuel with sulfur content greater than 5000 mg/kg (5000 ppm), contact an authorized John Deere dealer.

Sulfur Content for Other Engines

- Use of diesel fuel with sulfur content less than 5000 mg/kg (5000 ppm) is RECOMMENDED.
- Use of diesel fuel with sulfur content greater than 5000 mg/kg (5000 ppm) REDUCES the oil and filter change interval.

IMPORTANT: Do not mix used diesel engine oil or any other type of lubricating oil with diesel fuel.

Improper fuel additive usage may cause damage on fuel injection equipment of diesel engines.

MB60223,0000029 -19-29JUL21-1/1

CLICK HERE TO **DOWNLOAD** THE COMPLETE MANUAL

- Thank you very much for reading the preview of the manual.
- You can download the complete manual from: www.heydownloads.com by clicking the link below



- Please note: If there is no response to CLICKING the link, please download this PDF first and then click on it.

CLICK HERE TO **DOWNLOAD** THE COMPLETE MANUAL

Engine Oil and Filter Service Intervals — Interim Tier 4, Final Tier 4, Stage IIIB, Stage IV, and Stage V Engines

Failure to follow applicable oil standards and drain intervals can result in severe engine damage that might not be covered under warranty. Warranties, including the emissions warranty, are not conditioned on the use of John Deere oils, parts, or service.

Recommended oil and filter service intervals are based on a combination of oil pan capacity, type of engine oil and filter used, and sulfur content of the diesel fuel. Actual service intervals also depend on operation and maintenance practices.

Approved Oil Types:

- John Deere Plus-50™ II
- “Other Oils” include API CK-4, API CJ-4, ACEA E9, and ACEA E6

Use oil analysis to evaluate the condition of the oil and to aid in selection of the proper oil and filter service interval. Contact your John Deere dealer or other qualified service provider for more information on engine oil analysis.

Change the oil and oil filter at least once every 12 months even if the hours of operation are fewer than the otherwise recommended service interval.

Diesel fuel sulfur content affects engine oil and filter service intervals. Higher fuel sulfur levels reduce oil and filter service intervals.

Use of diesel fuel with sulfur content less than 15 mg/kg (15 ppm) is **REQUIRED**.

Plus-50 is a trademark of Deere & Company

Engine operation at high altitude decreases oil change intervals. See Diesel Engine Oil Service Interval for Operation at High Altitude for additional information.

NOTE: The 500 hour extended oil and filter change interval is only allowed if all of the following conditions are met:

- Use of diesel fuel with sulfur content less than 15 mg/kg (15 ppm)
- Use of John Deere Plus-50™ II oil
- Use of an approved John Deere oil filter

Engine Oil and Filter Service Intervals	
John Deere Plus-50™ II	500 hours
Other Oils	250 hours
Oil analysis may extend the service interval of “Other Oils” to a maximum not to exceed the interval of Plus-50™ II oils. Oil analysis means taking a series of oil samples at 50-hour increments beyond the normal service interval until either the data indicates the end of useful oil life or the maximum service interval of John Deere Plus-50 II oils is reached.	

IMPORTANT: To avoid engine damage:

- **Reduce oil and filter service intervals by 50% when using biodiesel blends greater than B20. Oil analysis may allow longer service intervals.**
- **Use only approved oil types.**

DX,ENOIL15,IT4,120toMAX -19-13JAN18-1/1

Diesel Engine Oil Service Interval for Operation at High Altitude

IMPORTANT: Diesel fuel sulfur content also affects engine oil and filter service intervals. See Engine Oil and Service Intervals in this section to determine the appropriate service interval prior to performing high altitude recommendations.

To avoid excessive oil degradation and potential engine damage, reduce oil and filter service intervals to 50% of the original recommended values when operating engines at altitudes above **1676 m (5500 ft)**.

Oil analysis may allow longer service intervals.

Use only approved oil types.

Example of Original Hours	Corresponding High Altitude Hours
125	60
150	75
175	85
200	100
250	125
275	135
300	150
350	175
375	185
400	200
500	250

TX,ENOIL,SERV,HIALT -19-24JUN20-1/1

Prepare Machine for Maintenance

Before performing maintenance procedures in the following chapters and before leaving operator's seat, park machine as described below unless another position is specified in the procedure.

1. Park machine on a level surface as shown.
2. Lower equipment to the ground.
3. Turn auto-idle switch (1) to the A/I OFF position.



IMPORTANT: Turbocharger can be damaged if procedure to shut down engine is not done properly.

4. Run engine with engine speed dial (2) at 1/3 position without load for 2 minutes.
5. Turn engine speed dial to slow idle position.
6. Turn key switch (3) to the OFF position. Remove key from switch.
7. Place pilot shutoff lever (4) to locked (UP) position.

IMPORTANT: Avoid machine damage. After turning key switch to OFF position, only turn battery disconnect switch to OFF position when indicator light no longer illuminates.

8. Turn battery disconnect switch to the OFF position. See Battery Disconnect Switch. (Section 2-3.)

1— Auto-Idle Switch
2— Engine Speed Dial

3— Key Switch
4— Pilot Shutoff Lever

Machine Position

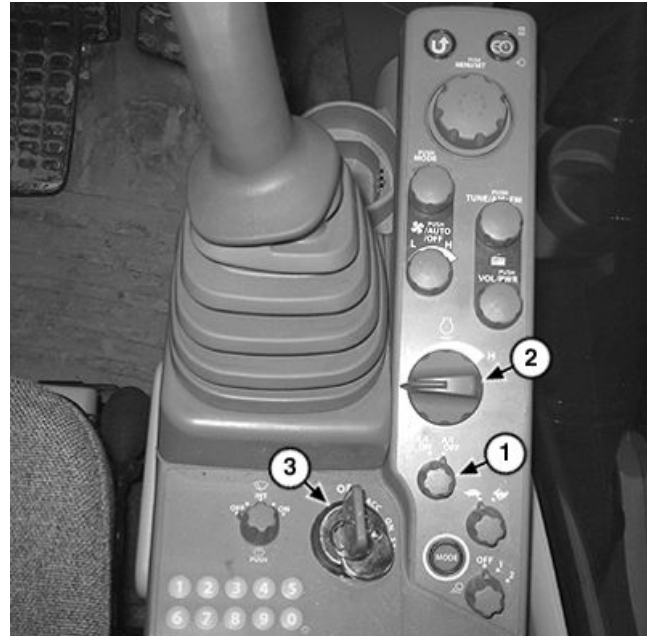

Switch Panel

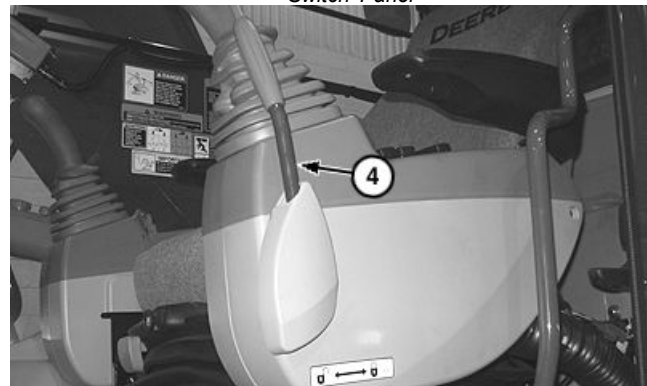

Pilot Shutoff Lever

T6811AI —UN—18OCT88

TX1087012A —UN—18JAN11

TX1087013A —UN—18JAN11

KR46761,0000C05 -19-19APR16-1/1

Clean Rear Camera Lens—If Equipped

CAUTION: Avoid personal injury. **DO NOT** climb on machine when inspecting or cleaning rear camera lens.

NOTE: The camera lens surface is a resin product. Lightly wipe the surface with a wet, clean cloth. Never use an organic solvent.

Inspect camera lens (1) for any accumulation of dirt, mud, snow, ice, or debris.

Clean lens as necessary.

1— Camera Lens



Rear Camera

TX1086324A —UN—28DEC10

ER79617.0000D75 -19-27JUL15-1/1

Service Exhaust Filter

CAUTION: Under federal, state, and/or local laws or regulations, exhaust filter ash may be classified as a hazardous waste. Hazardous waste must be disposed of in accordance with all applicable federal, state and local laws or regulations governing hazardous waste disposal. Only a qualified service provider should remove ash from the exhaust filter. See your authorized dealer for exhaust filter ash handling and disposal.

The exhaust filter (1) is designed to retain residual ash, which is a noncombustible result of additives used in crankcase lubrication oils and the fuel. As ash levels rise, the capacity for soot storage is reduced. Engine performance can be reduced due to increased exhaust system back pressure. The residual ash must be removed from the filter. Ash removal is performed by removing the exhaust filter from machine and having it cleaned by specialized equipment or replacing the exhaust filter.

Do **NOT** attempt to remove exhaust filter from machine. **Contact your authorized dealer to remove exhaust filter for ash removal or replacement.**

Failure to follow the approved ash removal methods may violate U.S. federal, state and local hazardous waste laws, along with damage to the exhaust filter resulting in potential denial of the emissions warranty.

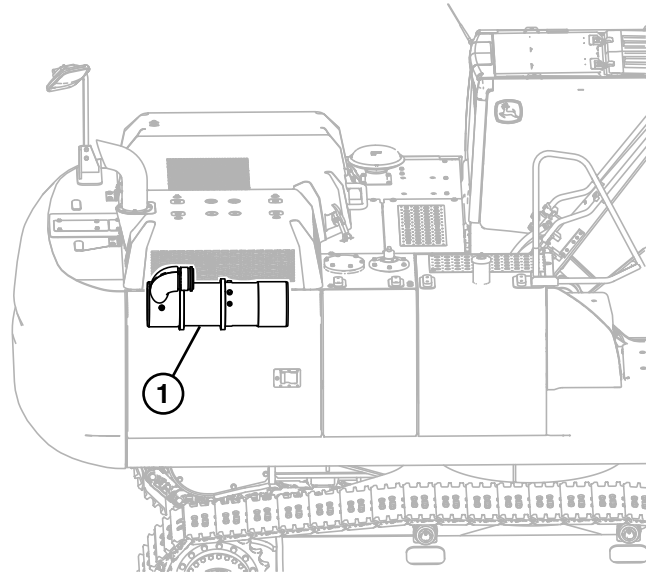

Exhaust Filter

1— Exhaust Filter

TX1156075 —UN—14MAR14

KR46761.0000BB4 -19-14MAR14-1/1

Maintenance—Every 250 Hours

Check Swing Gear Case Oil Level

1. Park machine on a level surface.

IMPORTANT: Turbocharger can be damaged if procedure to shutdown engine is not done properly.

2. Run engine at slow idle speed without load for 5 minutes.
3. Stop engine.
4. Remove dipstick (1). Wipe dipstick clean and replace completely into tube.
5. Remove dipstick. Oil must be in the dipstick cross-hatch area (3).
6. If necessary, remove filler cap (2) and add oil. See Swing Gear Case and Travel Gear Case Oils. (Section 3-1.)
7. Install filler cap.
8. Check oil level on dipstick.

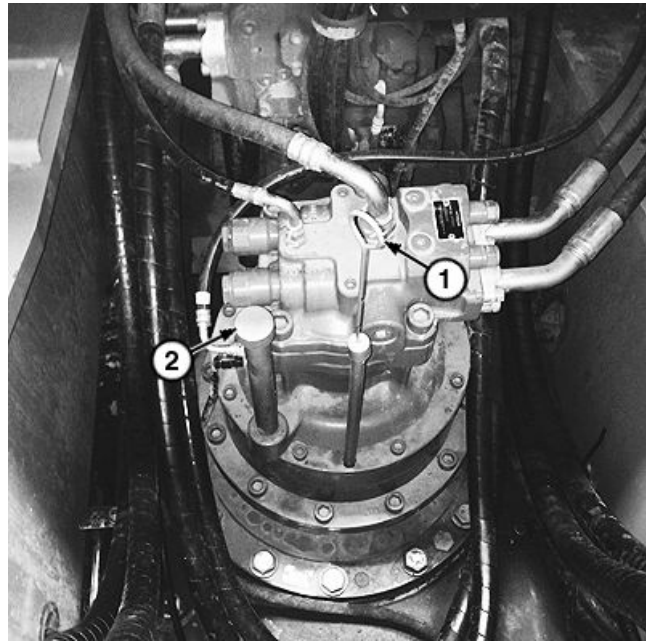

Swing Gear Case

1— Dipstick
2— Filler Cap

3— Dipstick Cross-Hatch Area

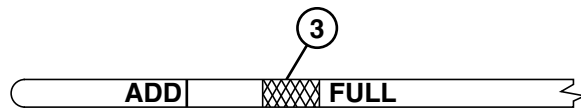

Dipstick Cross-Hatch Area

KR46761,0000BF8 -19-05MAR15-1/1

TX1156448A—UN—18MAR14

T216546—UN—29NOV05

Replace Auxiliary Fuel Filter and Water Separator—If Equipped

1. Ensure that key switch is in the OFF position.
2. Open right rear service door to access auxiliary fuel filter and water separator (1).
3. Thoroughly clean exterior of auxiliary fuel filter and water separator assembly and surrounding area.
4. Close fuel shutoff valve (if equipped) (4) located on inlet of auxiliary fuel filter.

NOTE: Drain waste into a container. Dispose of waste properly.

5. Loosen drain valve (3) to relieve pressure and drain contaminates from water separator bowl (2). Dispose of waste properly. Close drain valve.
6. Rotate auxiliary fuel filter counterclockwise and remove from mounting base. Remove water separator bowl from auxiliary fuel filter. Dispose of used fuel filter properly.
7. Clean filter mounting base.
8. Clean and dry water separator bowl. Replace if necessary.
9. Install water separator bowl to new auxiliary fuel filter.

IMPORTANT: DO NOT prefill fuel filters. Debris in unfiltered fuel will damage fuel system components.

Only lubricate filter seal with diesel fuel before installing.

10. Install new auxiliary fuel filter onto mounting base. Rotate filter housing clockwise by hand. Tighten 1/2—3/4 turn after seal contacts mounting base.
11. Open fuel shutoff valve (if equipped).
12. Prime fuel system and bleed air. See Bleed Fuel System. (Section 4-1.)
13. Operate engine and check for leaks.
14. Tighten filter element and bowl only enough to stop leaks.
15. Close service door.

1—Auxiliary Fuel Filter and Water Separator
2—Water Separator Bowl

3—Drain Valve
4—Fuel Shutoff Valve (if equipped)

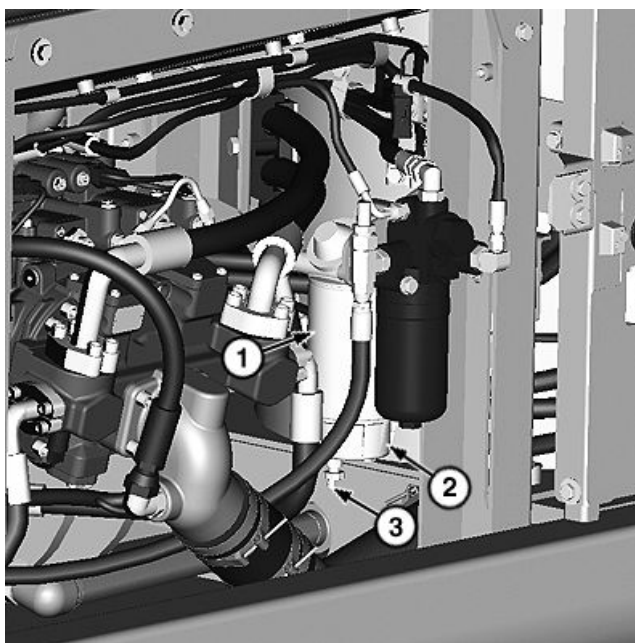

Auxiliary Fuel Filter and Water Separator

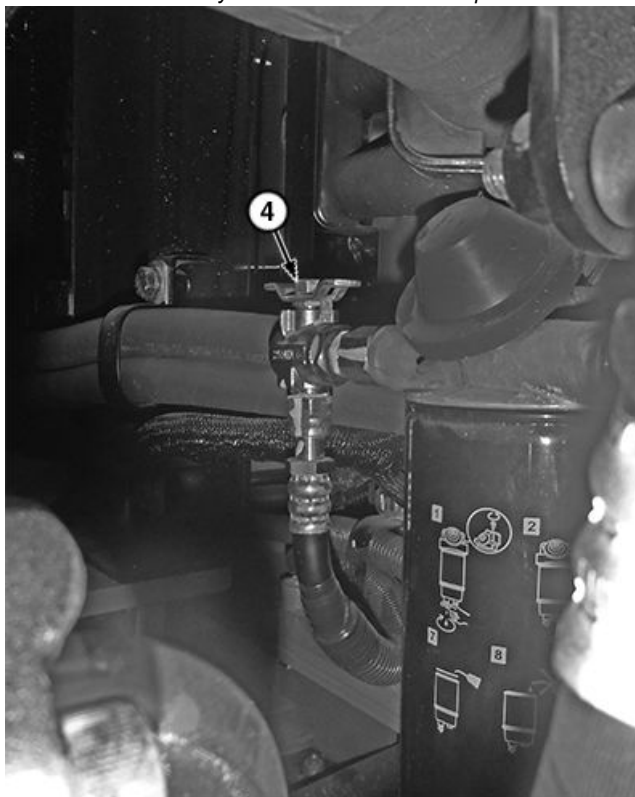

Fuel Shutoff Valve (if equipped)

TX1156858 —UN—27MAR14

TX1252146A —UN—08FEB18

TD48962.0000067 -19-09FEB18-1/1

Replace Air Cleaner Dust Unloader Valve

IMPORTANT: Avoid machine damage. A missing, damaged, or hardened air cleaner dust unloader valve (1) will make the dust cup precleaner ineffective, causing very short element life. Valve should suck closed when engine is running.

1. On left side of machine, open front service door to access dust unloader valve (1).
2. Twist and pull on dust unloader valve to remove dust unloader valve from the air cleaner cover.
3. Install new dust unloader valve on air cleaner cover.
4. Close service door.

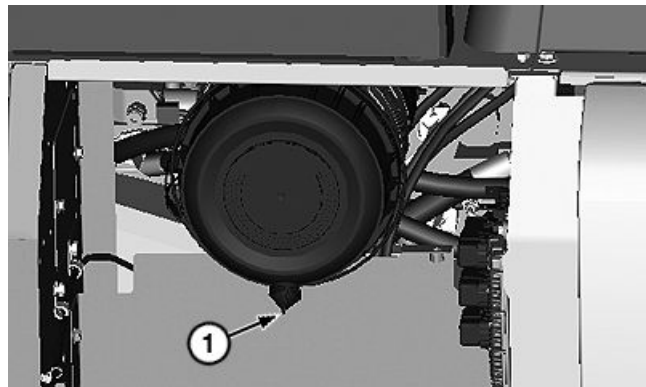

Dust Unloader Valve

1— Dust Unloader Valve

KR46761,0000BEE -19-29JAN15-1/1

TX1156004 —UN—27MAR14

Check Coolant Condition

CAUTION: Prevent possible injury from hot, spraying fluids. Shut off engine. Remove filler cap only when cool enough to touch with bare hands. Slowly loosen cap to relieve pressure before removing completely.

NOTE: Coolant should be checked every 1000 hours or 1 year, or when replacing 1/3 or more of coolant using SERVICEGARD™ tool program.

1. Open engine cover to access surge tank.
2. Test engine coolant. See Testing Coolant Freeze Point. (Section 3-1.)
3. Install surge tank cap.

SERVICEGARD is a trademark of Deere & Company

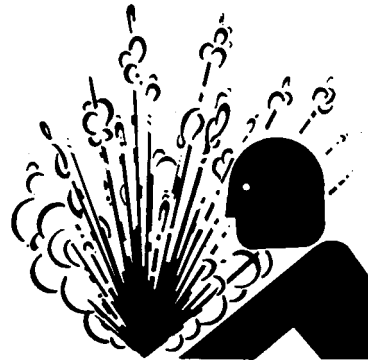

Pressurized Fluids

4. Close engine cover.

KR46761,0000BB7 -19-17APR17-1/1

TS281 —UN—15APR13

Cooling System Fill and Deaeration Procedure

CAUTION: Prevent possible injury from hot spraying fluids. Shut off engine. Remove filler cap only when cool enough to touch with bare hands. Slowly loosen cap to relieve pressure before removing completely.

IMPORTANT: Avoid mixing different brands or types of coolant. Coolant manufacturers engineer their coolants to meet certain specifications and performance requirements. Mixing different coolant types can degrade coolant and machine performance.

Use only permanent-type low silicate ethylene glycol base antifreeze in coolant solution. Other types of antifreeze may damage cylinder seals.

John Deere COOL-GARD™ II Pre-Mix coolant is recommended when adding new coolant to cooling system.

Follow directions on container for correct mixture ratio.

FREEZING TEMPERATURES: Fill with permanent-type, low silicate, ethylene glycol antifreeze (without stop-leak additive) and clean, soft water.

Fill

Remove surge tank cap (1) to relieve pressure. Fill surge tank to above the full hot mark. Replace surge tank cap.

Deaeration

The cooling system requires several warmup and cool down cycles to deaerate. It will NOT deaerate during normal operation. Only during warmup and cool down cycles will the system deaerate.

1. Start engine. Run engine until coolant reaches a warm temperature.
2. Stop engine. Allow coolant to cool.
3. Check coolant level at surge tank.
4. Repeat steps 1—3 until surge tank coolant level is repeatedly at the same level (stabilized).

NOTE: The level of the coolant in the cooling system **MUST BE** repeatedly checked after all drain and

COOL-GARD is a trademark of Deere & Company

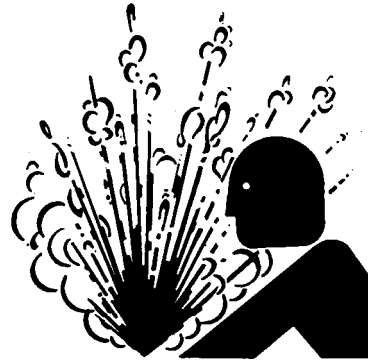

Pressurized Fluids

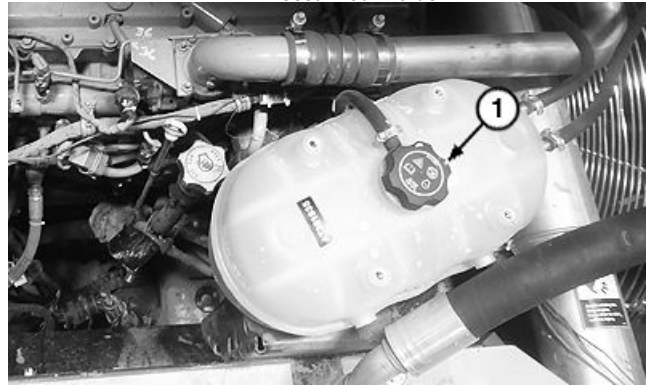

Surge Tank Cap

1— Surge Tank Cap

refill procedures to insure that all air is out of the system which allows the coolant level to stabilize. Check coolant level only when the engine is cold.

5. If necessary, fill surge tank to above the MIN COLD mark.

Specification

Cooling System—Capacity.....	23.0 L
	6.0 gal.

KR46761,0000BC7 -19-02APR14-1/1

TS281—UN—15APR13

TX1156018A—UN—10MAR14

A fully charged battery will have a corrected specific gravity reading of 1.260. If the reading is below 1.200, charge the battery.

SERVICEGARD is a trademark of Deere & Company

TX.SERV.BATT.CARE -19-02APR20-2/2

Using Battery Charger

12-Volt System

CAUTION: Prevent possible injury from exploding battery. Do not charge a battery if ambient temperature is below 0°C (32°F). Warm battery to 16°C (60°F) before charging.

Turn off charger before connecting or disconnecting it.

IMPORTANT: Do not use battery charger as a booster if a battery has a 1.150 specific gravity reading or lower.

Disconnect battery ground (-) clamp before charging batteries in the machine to prevent damage to electrical components.

NOTE: Some battery chargers may also be used as a booster to start the engine. Follow battery charger manufacturer's operating instruction before boosting.

1. Turn the battery disconnect switch (if equipped) to the OFF position.
2. Ventilate the area where battery is being charged.
3. Connect positive (+) cable to the positive (+) terminal of machine battery.
4. Connect negative (-) cable to the negative (-) terminal of machine battery.

CAUTION: Prevent possible injury from exploding battery. Follow battery charger manufacturer's operating instructions before charging.

IMPORTANT: Prevent battery or machine damage from improper use of charger. Follow battery charger manufacturer's operation instruction before charging.



Prevent Battery Explosions

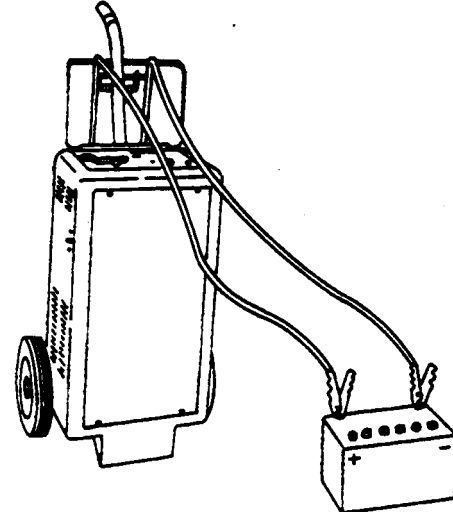

Charger

5. Stop or cut back charging rate if battery case becomes hot or is venting electrolyte. Battery temperature must not exceed 52°C (125°F).
6. Remove charger cables in reverse order of connection.

Continued on next page

KR46761,0000C06 -19-17AUG21-1/2

TS204—UN—15APR13

N36890—UN—07OCT88

Replacing Bucket Teeth

⚠ CAUTION: Guard against injury from flying pieces of metal; wear goggles or safety glasses.

IMPORTANT: Angle the drift toward the bucket to avoid damaging the rubber pin lock.

Check bucket teeth periodically so that wear does not extend to the bucket tooth shank.

1. Use a hammer and drift to drive out locking pin.

NOTE: Alternate buckets may use different tooth assemblies.

2. Remove tooth.
3. Inspect rubber pin lock (A) for damage. Replace if necessary.
4. If rubber pin lock has moved, reposition in slot in adapter tooth shank.
5. Position the new tooth over the tooth shank.
6. Drive the locking pin into the hole fully.

A—Rubber Pin Lock



Bucket Teeth



Rubber Pin Lock



Tooth Shank

T95784 —UN—10NOV88

T95785 —UN—10NOV88

T95786 —UN—10NOV88

04T,90,M16 -19-05JAN16-1/1

Horn Circuit Check

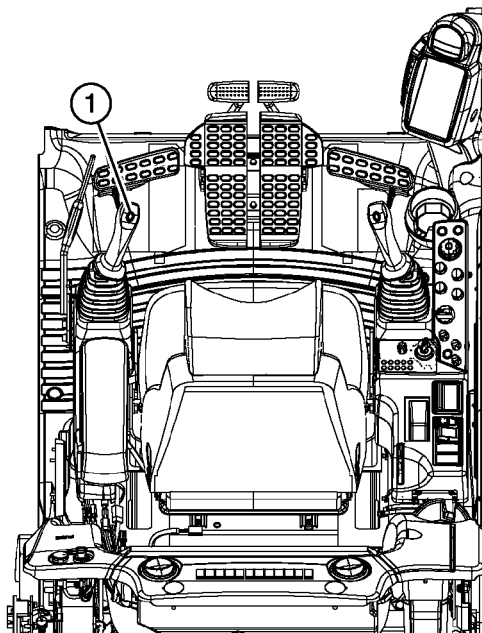

TX1159741 —UN—02MAY14

Horn Circuit

1—Horn Button

Key switch in OFF position.

Press horn button (1) on top of left pilot control lever.

LISTEN: Does horn sound?

YES: Go to next check.

NO: Check horn 10 A fuse (F19) (marked HORN). See Replacing Fuses. (Section 4-1.)

IF OK: See your authorized dealer.

Continued on next page

KR46761,0000C3E -19-13FEB18-5/52

Rear Cab Light (if equipped)



TX1250182A —UN—18JAN18

Rear Cab Light Switch

S36— Rear Cab Light Switch

NOTE: Rear cab light switch (S36) position may vary depending on machine configuration.

Turn rear cab light switch (S36) to the ON position.

LOOK: Is light illuminated on rear of cab?

YES: Go to next check.

NO: Check rear cab light 10 A fuse (F23) (marked CAB LAMP REAR). See Replacing Fuses. (Section 4-1.)

IF OK: See an authorized John Deere dealer.

Continued on next page

KR46761,0000C3E -19-13FEB18-16/52

H/P (high power) Mode Check

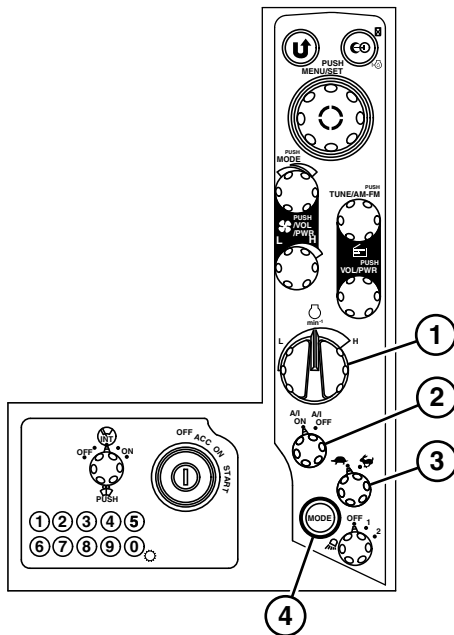

TX1086753 —UN—11JAN11

Switch Panel

- 1— Engine Speed Dial**
- 2— Auto-Idle Switch**
- 3— Travel Speed Switch**
- 4— Power Mode Button**

Turn auto-idle switch (2) to A/I OFF position.

Turn engine speed dial (1) to H (fast idle) position.

Press and release power mode button until H/P (high power) mode is displayed on monitor.

Actuate arm in function over relief.

LOOK/LISTEN: Does engine speed increase as function goes over relief?

YES: Go to next check.

NO: Check information controller and main controller battery power 5 A fuse (F10) (marked CONTROLLER). See Replacing Fuses. (Section 4-1.)

IF OK: See your authorized dealer.

Continued on next page

KR46761,0000C3E -19-13FEB18-28/52

**Dig Function Drift Check
(empty bucket)**



TX1109902 —UN—28JUN13

Machine Position—Empty Bucket

Empty bucket of material.

Extend arm cylinder, then retract about 50 mm (2 in).

Extend bucket cylinder, then retract about 50 mm (2 in).

Lower boom until arm tip position above ground (1) is 1 m (40 in).

Stop engine.

Measure amount cylinders extend or retract in 5 minutes.

Measure distance from arm tip to ground.

Compare measurements to specifications.

Dig Function Drift Specifications (empty bucket)—Specification

Boom Cylinder—Bucket Empty—Drift.....	5 mm
	0.20 in
Arm Cylinder—Bucket Empty—Drift.....	15 mm
	0.59 in
Bucket Cylinder—Bucket Empty—Drift.....	10 mm
	0.39 in
Arm Tip-to-Ground—Drift.....	110 mm
	4.33 in

LOOK: Is cylinder drift within specification?

YES: Go to next check.

NO: See your authorized dealer.

Continued on next page

KR46761,0000C3E -19-13FEB18-39/52

**Heater and Air
Conditioner Circuit
Check**

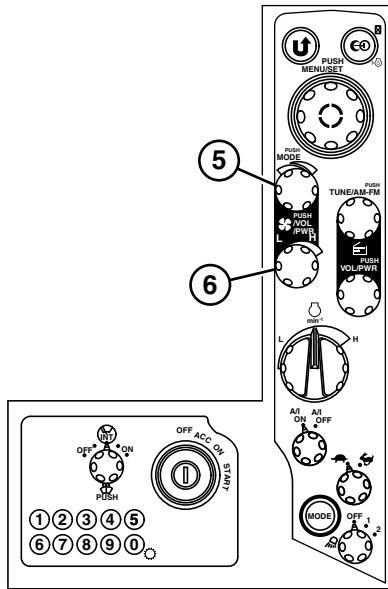

TX1086866 —UN—13JAN11

Switch Panel

- 5— Temperature Control/Mode Switch**
- 6— Blower Speed Switch**

Start engine and warm to normal operating temperature.

Turn temperature control/mode switch (5) clockwise to maximum heat position.

FEEL: Does warm air come from the vents?

Turn temperature control/mode switch counterclockwise to maximum cold position.

LISTEN: Does air conditioner compressor clutch solenoid "click"?

FEEL: Does cool air come from the vents?

YES: Checks complete.

NO: Heater does not operate. Check air conditioner and heater 20 A fuse (F3) (marked HEATER). See Replacing Fuses. (Section 4-1.)

IF OK: See your authorized dealer.

Continued on next page

KR46761,0000C3E -19-13FEB18-50/52

Symptom	Problem	Solution
	Water in oil	Drain hydraulic tank and refill with oil.
	Air leak in oil line from reservoir	Repair leak.
	Kinks or dents in oil lines	Inspect and correct.
No Swing Function	Pilot shutoff lever	Place pilot shutoff lever in unlocked (DOWN) position.
	Pilot control valve hoses pinched or kinked	Inspect and correct.
Swing Function is Jerky	Lack of grease in swing bearing	Fill with grease.
	Rocks or mud jammed in track frame	Remove and repair.
Slow Travel Speed Only	Pilot control valve hoses pinched or kinked	Inspect and correct.
	Cold oil	Perform hydraulic warm-up procedure.
Travel is Jerky	Engine speed too slow	Increase engine speed.
	Track sag adjustment	Adjust track sag.
	Rocks or mud jammed in track frame	Remove and repair.
Engine Stops When Travel or Control Lever Actuated	Air filters restricted or dirty	Replace air filter elements.
	Fuel filters restricted	Replace filters. Bleed air. Clean fuel tank inlet screen.
	Air in fuel system	Bleed air. See Bleed Fuel System. (Section 4-1.)

KR46761,0000C45 -19-19MAY16-2/2

Record Hydraulic Coupler Serial Number—If Equipped

Hydraulic Coupler Serial Number:

The hydraulic coupler serial number plate (1) is located on the front side of the coupler.

1— Hydraulic Coupler Serial Number Plate

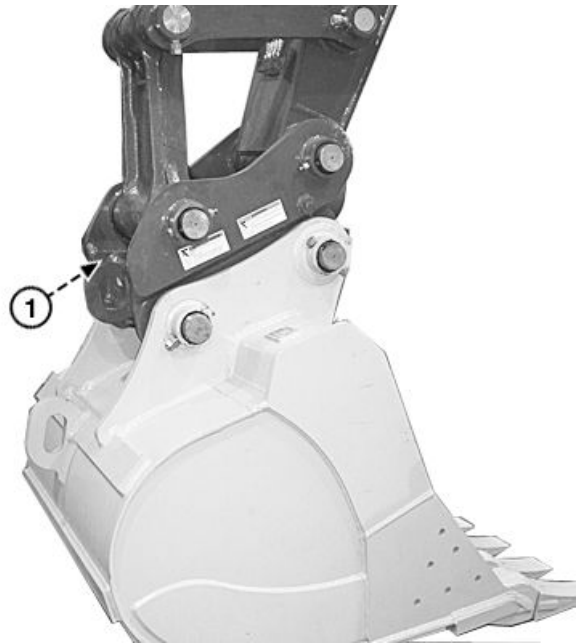

Hydraulic Coupler Serial Number Plate Location

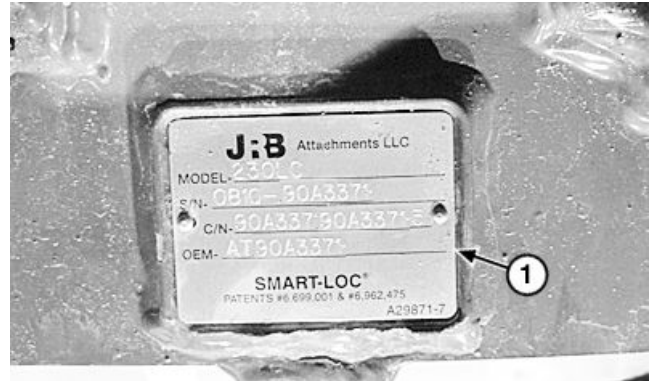

Hydraulic Coupler Serial Number Plate

TX1086497A—UN—04JAN11

TX1086500A—UN—04JAN11

ER79617,0000D8F -19-05JAN16-1/1

Record Hydraulic Pump Serial Number

Hydraulic Pump Serial Number

Open the right rear service door to access the hydraulic pump. The hydraulic pump serial number plate (1) is located on the front of the hydraulic pump.

1— Hydraulic Pump Serial Number Plate

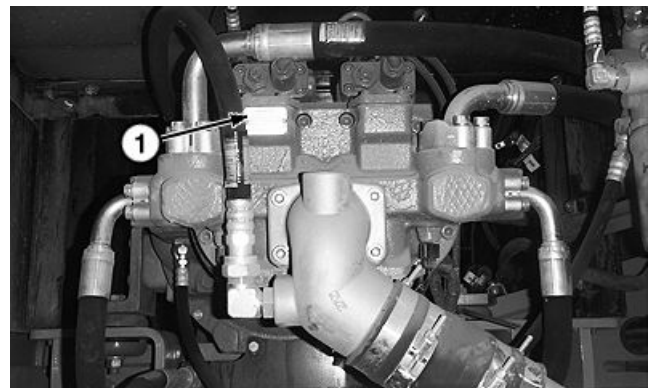

Hydraulic Pump Serial Number

TX1156402A—UN—17MAR14

KR46761,0000BF5 -19-11DEC17-1/1

Lift Capacity—Arm: 2.96 m (9 ft. 9 in.); Bucket: 871 kg (1920 lb.); Shoe: 700 mm (28 in.)

Ratings are at bucket lift hook, using standard counterweight, situated on firm, level, uniform supporting surface.

marked with an asterisk (*) are hydraulically-limited capacities. Remaining figures are stability-limited capacities.

Figures do not exceed 87 percent of hydraulic capacity or 75 percent of weight needed to tip machine. Figures

Arm: 2.96 m (9 ft. 9 in.)		Bucket: 871 kg (1920 lb.)			Shoe: 700 mm (28 in.)	
Power Dig: On						
LIFTING OVER FRONT						
Load Point Height	Horizontal Distance from Centerline of Rotation					
m (ft.)	1.5 (5)	3.0 (10)	4.5 (15)	6.0 (20)	7.5 (25)	
6.0 (20)				5126* (11 207*)	4261*	
4.5 (15)			7138* (15 343*)	5939* (12 881*)	5358* (11 712*)	
3.0 (10)			9529* (20 456*)	7053* (15 254*)	5900* (12 831*)	
1.5 (5)			11 578* (24 945*)	8135* (17 591*)	6109 (13 128)	
Ground Line			12 543* (27 129*)	8576 (18 423)	5973 (12 839)	
-1.5 (-5)		8446* (19 259*)	12 551* (27 188*)	8471 (18 196)	5919 (12 733)	
-3.0 (-10)	9964* (22 420*)	14 599* (33 304*)	11 732* (25 372*)	8509 (18 290)		
-4.5 (-15)		13 748* (29 522*)	9758* (20 866*)			
LIFTING OVER SIDE						
Load Point Height	Horizontal Distance from Centerline of Rotation					
m (ft.)	1.5 (5)	3.0 (10)	4.5 (15)	6.0 (20)	7.5 (25)	
6.0 (20)				5126* (11 207*)	4218	
4.5 (15)			7138* (15 343*)	5939* (12 881*)	4155 (8903)	
3.0 (10)			9253 (19 947)	5839 (12 571)	4012 (8610)	
1.5 (5)			8596 (18 513)	5515 (11 872)	3852 (8276)	
Ground Line			8277 (17 798)	5295 (11 393)	3728 (8013)	
-1.5 (-5)		8446* (19 259*)	8201 (17 622)	5203 (11 192)	3679 (7916)	
-3.0 (-10)	9964* (22 420*)	14 599* (33 304*)	8282 (17 803)	5237 (11 275)		
-4.5 (-15)		13 748* (29 522*)	8530 (18 366)			

* Hydraulically Limited Capacities

KR46761,0000C10 -19-27MAR14-1/1

CLICK HERE TO **DOWNLOAD** THE COMPLETE MANUAL

- Thank you very much for reading the preview of the manual.
- You can download the complete manual from: www.heydownloads.com by clicking the link below



- Please note: If there is no response to CLICKING the link, please download this PDF first and then click on it.

CLICK HERE TO **DOWNLOAD** THE COMPLETE MANUAL