

2154D Log Loader



JOHN DEERE

OPERATOR'S MANUAL

2154D Log Loader

OMT231419 ISSUE L3 (ENGLISH)



CALIFORNIA

Proposition 65 Warning

Diesel engine exhaust and some of its constituents are known to the State of California to cause cancer, birth defects, and other reproductive harm.

If this product contains a gasoline engine:

WARNING

The engine exhaust from this product contains chemicals known to the State of California to cause cancer, birth defects or other reproductive harm.

The State of California requires the above two warnings.

**Worldwide Construction,
And Forestry Division**

PRINTED IN U.S.A.

CLICK HERE TO **DOWNLOAD** THE COMPLETE MANUAL

- Thank you very much for reading the preview of the manual.
- You can download the complete manual from: www.heydownloads.com by clicking the link below



- Please note: If there is no response to CLICKING the link, please download this PDF first and then click on it.

CLICK HERE TO **DOWNLOAD** THE COMPLETE MANUAL

**Required Emission-Related Information
Service Provider**

A repair shop or person of the owner's choosing may maintain, replace, or repair emission control devices and systems with original or equivalent replacement parts. However, warranty, recall, and all other services paid for by John Deere must be performed at an authorized John Deere service center.

DX,EMISSIONS,REQINFO-19-08DEC23-1/1

Technical Information Feedback Form

We need your help to continually improve our technical publications. Please copy this page and FAX or mail your comments, ideas and improvements.

SEND TO: John Deere Dubuque Works
18600 South John Deere Road
Attn: Publications, Dept. 324
Dubuque, IA 52004-0538
USA

FAX NUMBER: 1-563-589-5800 (USA)

Publication Number: _____

Page Number: _____

Ideas, Comments: _____

Name: _____

Phone: _____

Email Address: _____

THANK YOU!

TX,TM,FAX-19-03JUL01-1/1

Stay Clear of Moving Parts

Entanglements in moving parts can cause serious injury.

Stop engine before examining, adjusting or maintaining any part of machine with moving parts.

Keep guards and shields in place. Replace any guard or shield that has been removed for access as soon as service or repair is complete.

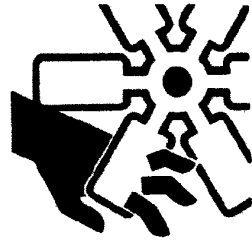

T133592—UN—15APR13

TX03679,00016D2-19-03JAN07-1/1

Avoid High-Pressure Fluids

Inspect hydraulic hoses periodically – at least once per year – for leakage, kinking, cuts, cracks, abrasion, blisters, corrosion, exposed wire braid or any other signs of wear or damage.

Replace worn or damaged hose assemblies immediately with John Deere approved replacement parts.

Escaping fluid under pressure can penetrate the skin causing serious injury.

Avoid the hazard by relieving pressure before disconnecting hydraulic or other lines. Tighten all connections before applying pressure.

Search for leaks with a piece of cardboard. Protect hands and body from high-pressure fluids.

If an accident occurs, see a doctor immediately. Any fluid injected into the skin must be surgically removed within a few hours or gangrene may result. Doctors unfamiliar with

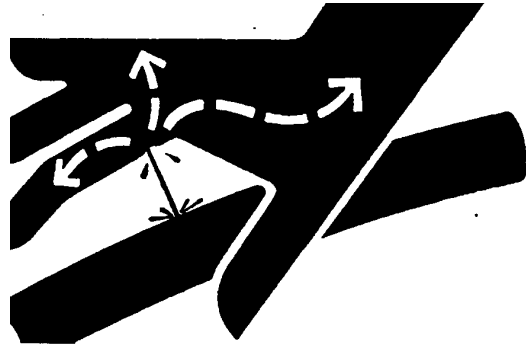

X9811—UN—23AUG88

this type of injury should reference a knowledgeable medical source. Such information is available in English from Deere & Company Medical Department in Moline, Illinois, U.S.A., by calling 1-800-822-8262 or +1 309-748-5636.

DX,FLUID-19-12OCT11-1/1

Avoid High-Pressure Oils

This machine uses a high-pressure hydraulic system. Escaping oil under pressure can penetrate the skin causing serious injury.

Never search for leaks with your hands. Protect hands. Use a piece of cardboard to find location of escaping oil. Stop engine and relieve pressure before disconnecting lines or working on hydraulic system.

If hydraulic oil penetrates your skin, see a doctor immediately. Injected oil must be removed surgically within hours or gangrene may result. Contact a knowledgeable medical source or the Deere & Company Medical Department in Moline, Illinois, U.S.A.



T133509—UN—15APR13

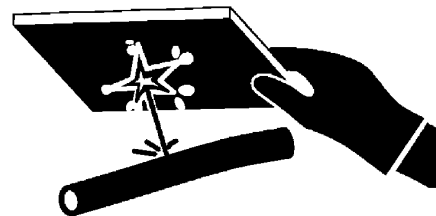

T133840—UN—20SEP00

TX03679,00016D3-19-03NOV08-1/1

Safety—Maintenance Precautions

Park and Prepare for Service Safely

Warn others of service work. Always park and prepare your machine for service or repair properly.

- Park machine on a level surface and lower equipment and attachments to the ground.
- Place pilot shutoff lever in “lock” position. Stop engine and remove key.
- Attach a “Do Not Operate” tag in an obvious place in the operator’s station.

Securely support machine or attachment before working under it.

- Do not support machine with boom, arm, or other hydraulically actuated attachments.
- Do not support machine with cinder blocks or wooden pieces that may crumble or crush.
- Do not support machine with a single jack or other devices that may slip out of place.

Understand service procedures before beginning repairs. Keep service area clean and dry. Use two people whenever the engine must be running for service work.

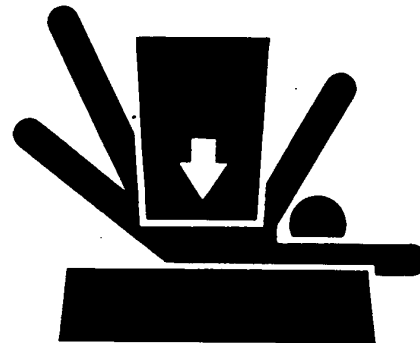

T133332—19—17APR13

TS229—UN—23AUG88

TX03679,00016E9-19-03JAN07-1/1

Service Machines Safely

Tie long hair behind your head. Do not wear a necktie, scarf, loose clothing, or necklace when you work near machine tools or moving parts. If these items were to get caught, severe injury could result.

Remove rings and other jewelry to prevent electrical shorts and entanglement in moving parts.

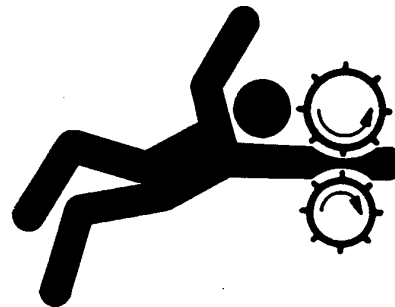

Service Machines Safely

TS228—UN—23AUG88

OUTJ002,00004BA-19-04FEB14-1/1

Service Cooling System Safely

Explosive release of fluids from pressurized cooling system can cause serious burns.

Do not service radiator through the radiator cap. Only fill through the surge tank filler cap. Shut off engine. Only remove surge tank filler cap when cool enough to touch with bare hands. Slowly loosen cap to relieve pressure before removing completely.



TS281—UN—15APR13

TX.SURGE-19-19JAN11-1/1

Front Switch Panel

- 1—Engine Speed Dial
- 2—Auto-Idle/Auto-Acceleration Switch
- 3—Power Mode Switch
- 4—Travel Speed Switch
- 5—Operating Lights Switch
- 6—Washer/Wiper Switch

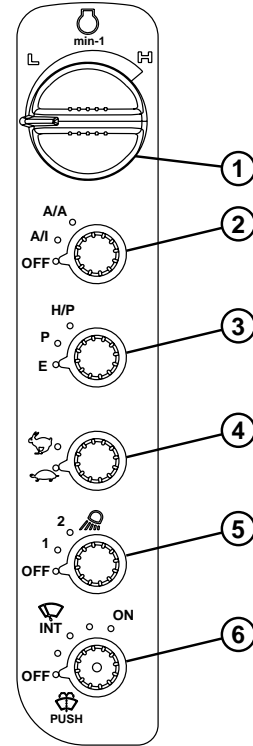

T136155—UN—18DEC00

DW90712.0000562-19-21APR08-1/1

Adjusting the Air Suspension Seat—If Equipped

- With the vehicle at a standstill and the driver on the seat sitting still, briefly pull the weight and height adjustment lever (1) to adjust seat for the driver's weight.
- To adjust the angle of the seat pan, lift the seat pan angle adjustment handle (2). Move seat pan to the desired angle and release handle.
- The shock absorber lever (3) has two settings, soft and hard. Turn lever clockwise to the soft position. Turn counterclockwise for the hard position.

NOTE: Before adjusting the height, adjust shock absorbers to the soft position.

IMPORTANT: Avoid damage. Do not operate compressor for more than 1 minute.

- The seat height can be set pneumatically and is continuously adjustable. To adjust seat height, pull or press weight and height adjustment lever fully out or in.
- Turn the seat heater ON and OFF by pressing the seat heater switch (4).
- Lift the locking bar (5) to adjust the fore/aft position.
- To adjust the depth of the seat cushion, lift the seat depth adjustment handle (6). Move the seat cushion backwards or forward to the desired position.
- The height and angle of the headrest (7) can be adjusted. To adjust the height, pull the headrest upward to the desired position. To adjust the angle of the headrest, push it forward or rearward. To remove the headrest, pull it upward past the end stop.

NOTE: The locking lever must latch into the desired position. It should not be possible to move the backrest into another position when it is locked.

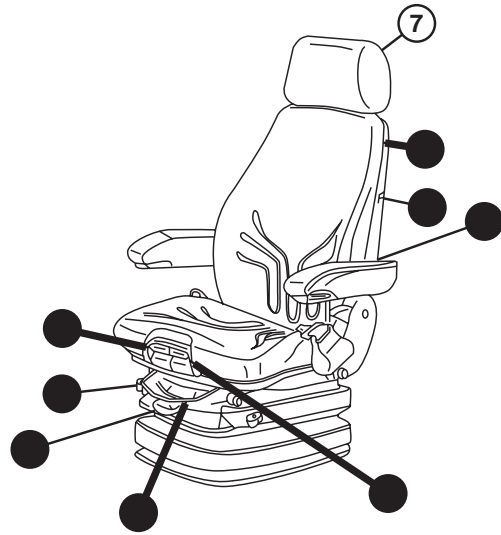

- | | |
|--------------------------------------|--------------------------------|
| 1—Weight and Height Adjustment Lever | 6—Seat Depth Adjustment Handle |
| 2—Seat Pan Angle Adjustment Handle | 7—Headrest |
| 3—Shock Absorber Lever | 8—Backrest Adjustment Lever |
| 4—Seat Heater Switch | 9—Lumbar Support Knob |
| 5—Locking Bar | |

- Pull the backrest adjustment lever (8) upward to adjust the backrest position. Release lever at desired position.
- To adjust the height and curvature of the lumbar support, turn the lumbar support knob (9) left or right.

TX1030118—UN—19AUG10

DW90712.00004DD-19-30SEP08-1/1

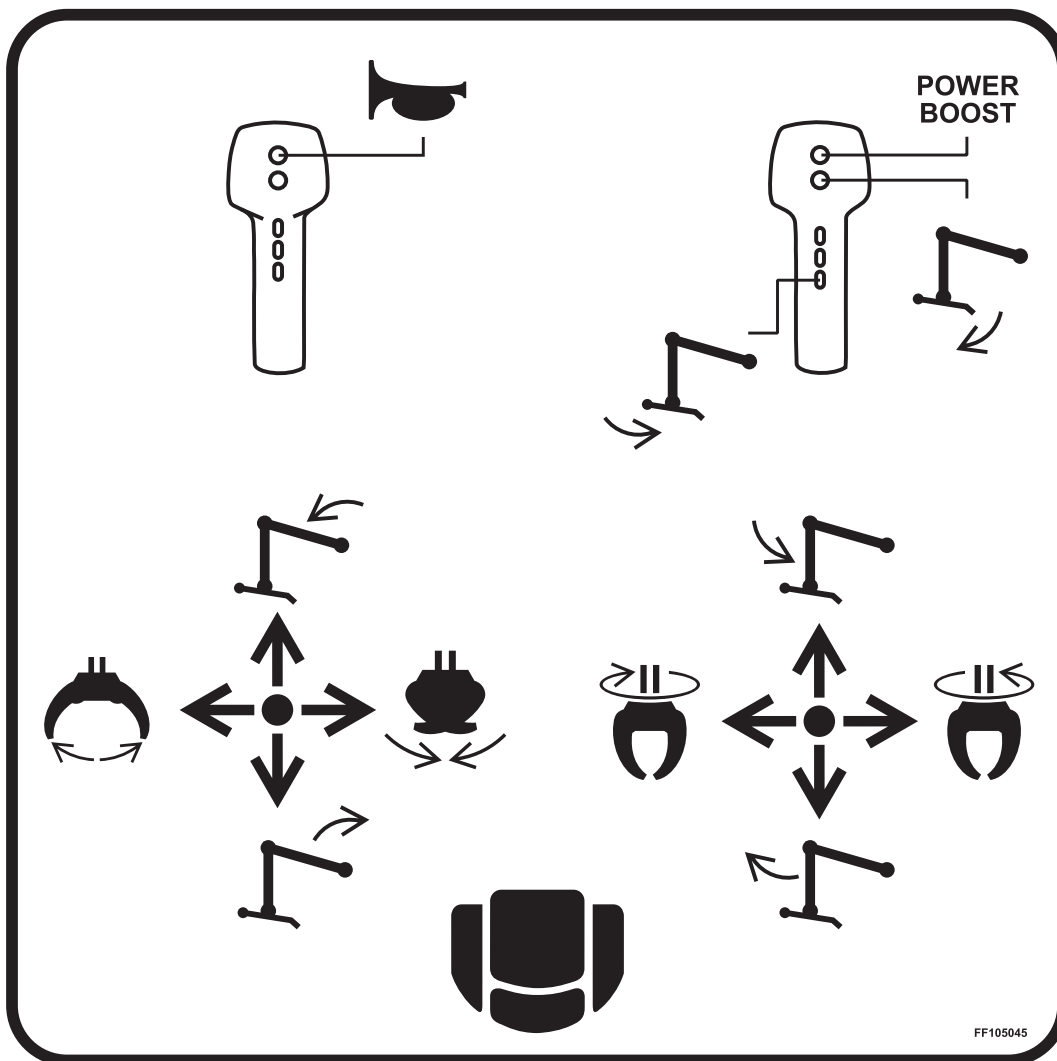

TX1043713

Control Lever Pattern—Live Heel With Knuckle Boom Loader (KBL)

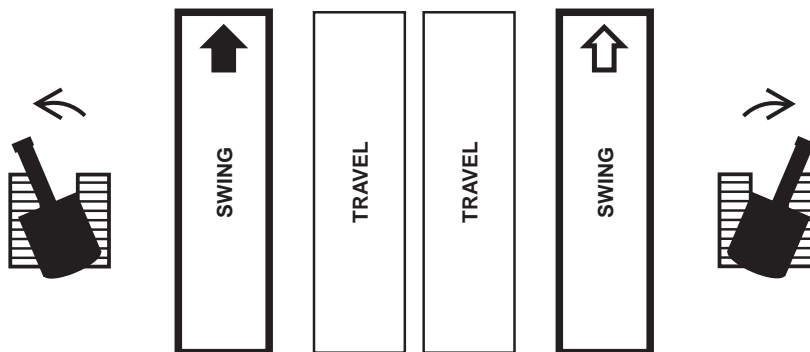

Foot Swing Pedal Operation

Continued on next page

OUT4001,000016A-19-03JUL08-3/7

TX1043713—19—12JUN08

TX1043722—19—20JUN08

Control Levers—Butt-N-Top Grapple

⚠ CAUTION: Never place any part of body beyond window frame. It could be crushed by the boom if boom control lever is accidentally bumped or otherwise engaged. If window is missing or broken, replace immediately.

Prevent possible injury from unexpected machine movement. Make sure you know the location and function of each control before operating.

With this control pattern, functions must correspond to the black-on-white labels located on the control console.

IMPORTANT: When operating, avoid contact with cab, cylinders, hoses or tracks with grapple or load.

1. Operate control levers to verify that control pattern labels match machine operation. See Control Lever Switches—Butt-N-Top. (Section 2-1.)
2. Replace labels if they do not match machine movement.

Continued on next page

DW90712,000063B-19-19JUN08-1/2

Maintenance—Machine

Diesel Fuel

Consult your local fuel distributor for properties of the diesel fuel available in your area.

In general, diesel fuels are blended to satisfy the low temperature requirements of the geographical area in which they are marketed.

Diesel fuels specified to EN 590 or ASTM D975 are recommended. Renewable diesel fuel produced by hydrotreating animal fats and vegetable oils is basically identical to petroleum diesel fuel. Renewable diesel that meets EN 590, ASTM D975, or EN 15940 is acceptable for use at all percentage mixture levels.

Required Fuel Properties

In all cases, the fuel shall meet the following properties:

Cetane number of 40 minimum. Cetane number greater than 47 is preferred, especially for temperatures below -20°C (-4°F) or elevations above 1675 m (5500 ft.).

Cloud Point should be below the expected lowest ambient temperature or **Cold Filter Plugging Point (CFPP)** should be a maximum 10°C (18°F) below the fuel cloud point.

Fuel lubricity should pass a maximum scar diameter of 0.52 mm as measured by ASTM D6079 or ISO 12156-1. A maximum scar diameter of 0.45 mm is preferred.

Diesel fuel quality and sulfur content must comply with all existing emissions regulations for the area in which the engine operates. **DO NOT** use diesel fuel with sulfur content greater than 10 000 mg/kg (10 000 ppm).

Materials such as copper, lead, zinc, tin, brass and bronze should be avoided in fuel handling, distribution and storage equipment as these metals can catalyze fuel oxidation reactions which can lead to fuel system deposits and plugged fuel filters.

E-Diesel fuel

DO NOT use E-Diesel (Diesel fuel and ethanol blend). Use of E-Diesel fuel in any John Deere machine may void the machine warranty.

 **CAUTION: Avoid severe injury or death due to the fire and explosion risk from using E-Diesel fuel.**

¹ See *DX, ENOIL12, OEM, DX, ENOIL12, T2, STD, or DX, ENOIL12, T2, EXT* for more information on Engine Oil and Filter Service Intervals.

Sulfur Content for Interim Tier 4, Final Tier 4, Stage III B, Stage IV, and Stage V Engines Above 560 kW

- Use ONLY diesel fuel with a maximum of 500 mg/kg (500 ppm) sulfur content.

Sulfur Content for Interim Tier 4, Final Tier 4, Stage III B, Stage IV Engines, and Stage V Engines

- Use ONLY ultra low sulfur diesel (ULSD) fuel with a maximum of 15 mg/kg (15 ppm) sulfur content.

Sulfur Content for Tier 3 and Stage III A Engines

- Use of diesel fuel with sulfur content less than 1000 mg/kg (1000 ppm) is RECOMMENDED.
- Use of diesel fuel with sulfur content 1000—2000 mg/kg (1000—2000 ppm) REDUCES the oil and filter change interval.
- BEFORE using diesel fuel with sulfur content greater than 2000 mg/kg (2000 ppm), contact your John Deere dealer.

Sulfur Content for Tier 2 and Stage II Engines

- Use of diesel fuel with sulfur content less than 2000 mg/kg (2000 ppm) is RECOMMENDED.
- Use of diesel fuel with sulfur content 2000—5000 mg/kg (2000—5000 ppm) REDUCES the oil and filter change interval.¹
- BEFORE using diesel fuel with sulfur content greater than 5000 mg/kg (5000 ppm), contact your John Deere dealer.

Sulfur Content for Other Engines

- Use of diesel fuel with sulfur content less than 5000 mg/kg (5000 ppm) is RECOMMENDED.
- Use of diesel fuel with sulfur content greater than 5000 mg/kg (5000 ppm) REDUCES the oil and filter change interval.

IMPORTANT: Do not mix used diesel engine oil or any other type of lubricating oil with diesel fuel.

Improper fuel additive usage may cause damage on fuel injection equipment of diesel engines.

DX,FUEL1-19-01NOV22-1/1

Diesel Engine Oil — Tier 3 and Stage IIIA

Failure to follow applicable oil standards and drain intervals can result in severe engine damage that might not be covered under warranty. Warranties, including the emissions warranty, are not conditioned on the use of John Deere oils, parts, or service.

Use oil viscosity based on the expected air temperature range during the period between oil changes.

John Deere Plus-50™ II oil is preferred.

John Deere Plus-50™ is also recommended.

John Deere Torq-Gard™ is also allowed.

Other oils may be used if they meet one or more of the following standards:

- API Service Category CK-4
- API Service Category CJ-4
- API Service Category CI-4 PLUS
- API Service Category CI-4
- ACEA Oil Sequence E9
- ACEA Oil Sequence E7
- ACEA Oil Sequence E6
- ACEA Oil Sequence E5
- ACEA Oil Sequence E4

Multi-viscosity diesel engine oils are preferred.

Diesel fuel quality and fuel sulfur content must comply with all existing emissions regulations for the area in which the engine operates.

*Plus-50 is a trademark of Deere & Company
Torq-Gard is a trademark of Deere & Company*

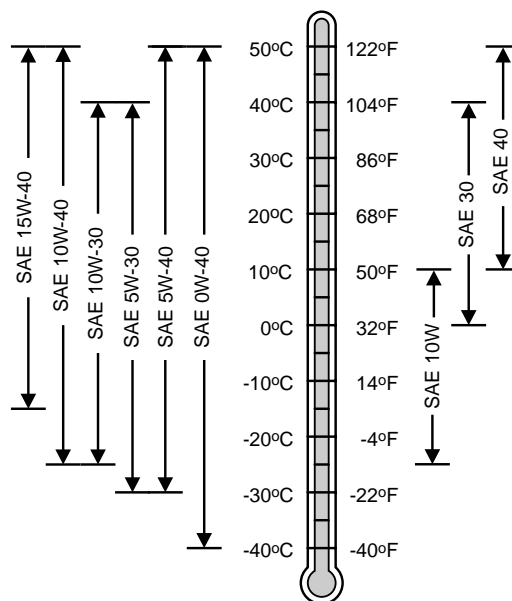

Oil Viscosities for Air Temperature Ranges

DO NOT use diesel fuel with sulfur content greater than 10 000 mg/kg (10 000 ppm).

TS1743—UN—25APR19

DX,ENOIL11-19-23APR19-1/1

Testing Diesel Engine Coolant

Maintaining adequate concentrations of glycol and inhibiting additives in the coolant is critical to protect the engine and cooling system against freezing, corrosion, and cylinder liner erosion and pitting.

Test the coolant solution at intervals of 12 months or less and whenever excessive coolant is lost through leaks or overheating.

Coolant Test Strips

Coolant test strips are available from your John Deere dealer. These test strips provide a simple, effective method to check the freeze point and additive levels of your engine coolant.

When Using John Deere COOL-GARD II

John Deere COOL-GARD II Premix™, COOL-GARD II PG Premix and COOL-GARD II Concentrate are maintenance free coolants for up to six years or 6000 hours of operation, provided that the cooling system is topped off using only John Deere COOL-GARD II Premix or COOL-GARD II PG premix. Test the coolant condition annually with coolant test strips designed for use with John Deere COOL-GARD II coolants. If the test strip chart indicates that additive is required, add John Deere COOL-GARD II Coolant Extender as directed.

COOL-GARD is a trademark of Deere & Company

Add only the recommended concentration of John Deere COOL-GARD II Coolant Extender. DO NOT add more than the recommended amount.

When Using Nitrite-Containing Coolants

Compare the test strip results to the supplemental coolant additive (SCA) chart to determine the amount of inhibiting additives in your coolant and whether more John Deere Liquid Coolant Conditioner should be added.

Add only the recommended concentration of John Deere Liquid Coolant Conditioner. DO NOT add more than the recommended amount.

Coolant Analysis

For a more thorough evaluation of your coolant, perform a coolant analysis. The coolant analysis can provide critical data such as freezing point, antifreeze level, pH, alkalinity, nitrite content (cavitation control additive), molybdate content (rust inhibitor additive), silicate content, corrosion metals, and visual assessment.

Contact your John Deere dealer for more information on coolant analysis.

DX,COOL9-19-11APR11-1/1

Check Track Sag

1. Swing upperstructure 90° to tracks and position boom, arm, and front attachment as shown.
 2. Raise track off ground with boom.
- ⚠ CAUTION: Prevent possible injury from unexpected machine movement. Place blocks under machine frame to support machine while measuring track sag.**
3. Place blocks under machine frame to support machine.
 4. Rotate track forward two full rotations and then in reverse two full rotations.

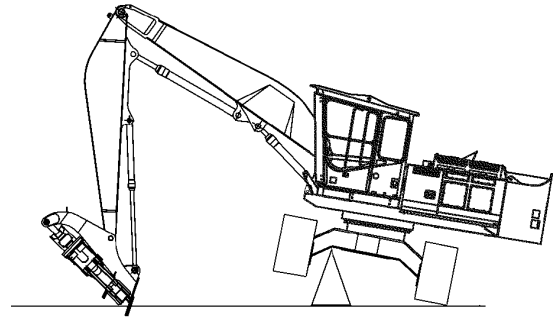

TX1041024—UN—23APR08

Live Heel and Fixed Heel Grapple Position (Live Heel Shown)

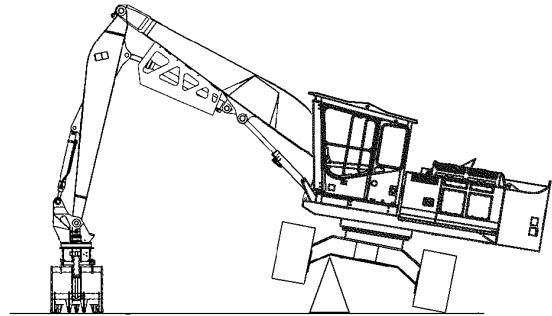

TX1041025—UN—23APR08

Articulated Grapple With Valve-In-Head Position

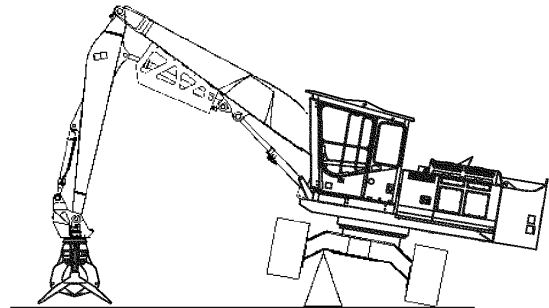

TX1041023—UN—23APR08

Butt-N-Top Grapple With Valve-In-Head Position

OUT4001,000016E-19-03JUL08-1/2

5. Measure distance (1) at middle track roller from bottom of track frame to top surface of track shoe.

2154D — Specification

Track—Sag 310—345 mm
 12.21—13.58 in.

1—Track Roller Distance

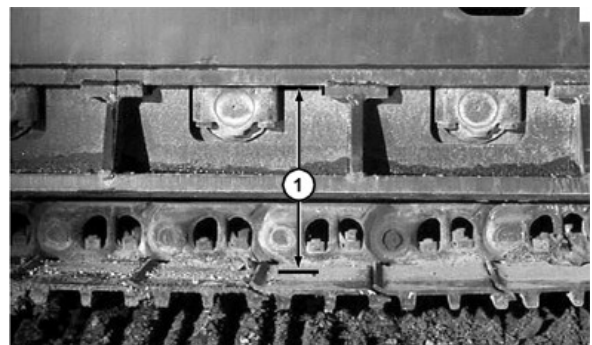

T125273—UN—22NOV99

OUT4001,000016E-19-03JUL08-2/2

Maintenance—Initial Service - 250 Hours

Change Engine Break-In Oil and Replace Filter

NOTE: Change engine break-in oil after 250 hours.

1. Run engine to warm oil.
 2. Park machine on a level surface.
 3. Stop engine.
 4. Remove three cap screws on lower engine cover to access the engine oil pan.
 5. Remove environmental drain cap (1).
 6. Install environmental drain hose.
 7. Turn valve (2) to open environmental drain.
 8. Allow oil to drain into a container.
 9. Close environmental drain valve, and remove environmental drain hose.
 10. Install environmental drain cap.
 11. Dispose of waste oil properly.
 12. Close door on lower engine cover, and install three cap screws to secure door.
 13. Turn filter (3) counterclockwise to remove. Clean mounting surface on base.
 14. Apply thin film of oil to rubber gasket of new filter.
 15. Tighten filter 1/2—3/4 turn more.
 16. Remove filler cap (4).
 17. Add oil to specification.
- Specification**
- | | |
|---------------------------|-------------------|
| Engine Oil With Filter | |
| Change—Capacity | 23.0 L
6.1 gal |
18. Install filler cap.
 19. Start engine.
 20. Stop engine. Check oil level.
 21. Check for any leakage at filter. Tighten filter just enough to stop leakage.

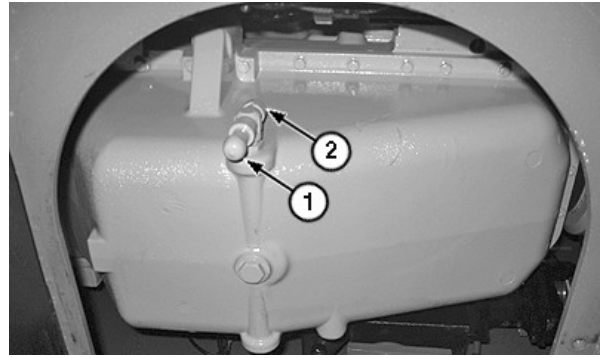

TX1019155A—UN—15FEB07

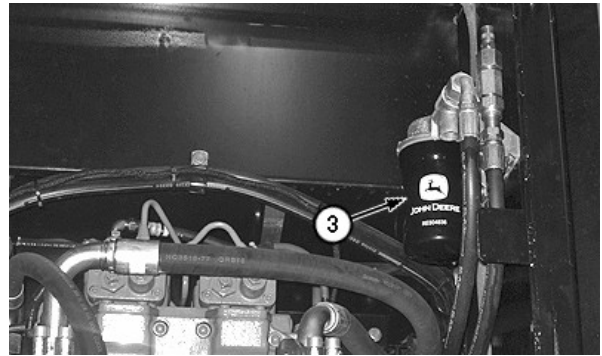

TX1019153A—UN—15FEB07

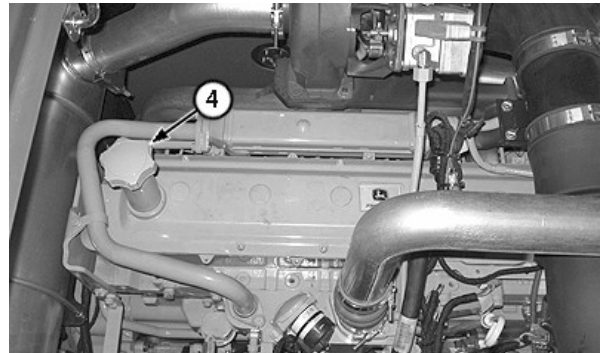

TX1019159A—UN—15FEB07

1—Environmental Drain Cap 3—Filter
2—Valve 4—Filler Cap

OUT4001,0000152-19-26APR17-1/1

CLICK HERE TO **DOWNLOAD** THE COMPLETE MANUAL

- Thank you very much for reading the preview of the manual.
- You can download the complete manual from: www.heydownloads.com by clicking the link below



- Please note: If there is no response to CLICKING the link, please download this PDF first and then click on it.

CLICK HERE TO **DOWNLOAD** THE COMPLETE MANUAL

Replace Water Separator

1. Turn retaining ring (1) counterclockwise to remove water separator filter (2). Allow sediment to drain into a container. Dispose of waste properly.
2. Turn sediment bowl (3) counterclockwise to remove from filter assembly. Clean bowl.
3. Install new filter. Follow instructions on filter.
4. Install sediment bowl.

IMPORTANT: For John Deere Tier 3 engines and beyond: Do not prefill fuel filters. Debris in unfiltered fuel will damage fuel system components. For engine identification, see Engine Identification. (Section 3-2.)

5. Bleed fuel system. See Bleed Fuel System. (Section 4-1.)

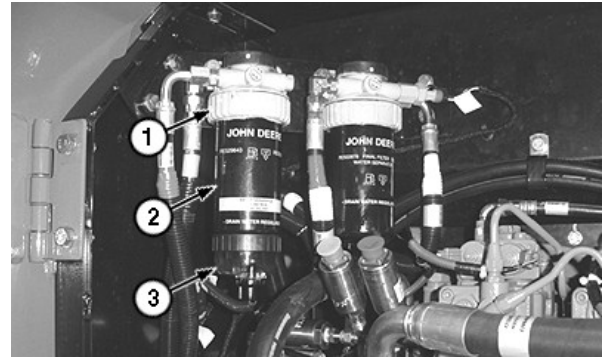

1—Retaining Ring
2—Water Separator Filter

3—Sediment Bowl

TX1041156A—UN—23APR08

DW90712,00005BE-19-24JUN10-1/1

Replace Final Fuel Filter

1. Turn retaining ring (1) clockwise to remove filter (2). Allow sediment to drain into a container. Dispose of waste properly.
2. Clean filter base.
3. Install new filter. Follow instructions on filter.
4. Bleed fuel system. See Bleed Fuel System. (Section 4-1.)

IMPORTANT: For John Deere Tier 3 engines and beyond: Do not prefill fuel filters. Debris in unfiltered fuel will damage fuel system components. For engine identification, see Engine Identification. (Section 3-2.)

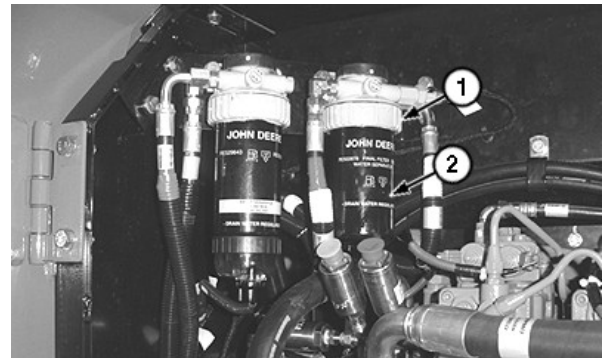

1—Retaining Ring

2—Fuel Filter

TX1041173A—UN—23APR08

DW90712,00005BF-19-24JUN10-1/1

Replace Air Cleaner Elements

1. Lift lever (1) to unlock cover.
2. Rotate cover counterclockwise, and remove cover.
3. Remove primary element (2).
4. Remove secondary element (3).
5. Clean inside of filter canister.
6. Install new elements, making sure the secondary element is centered in canister.
7. Install cover and lock by rotating clockwise until “LOCK” symbol is aligned with arrows on body.

1—Lever

2—Primary Element

3—Secondary Element

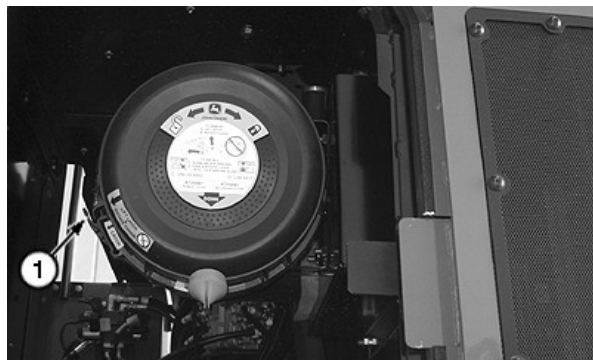

TX1041189A—UN—23APR08

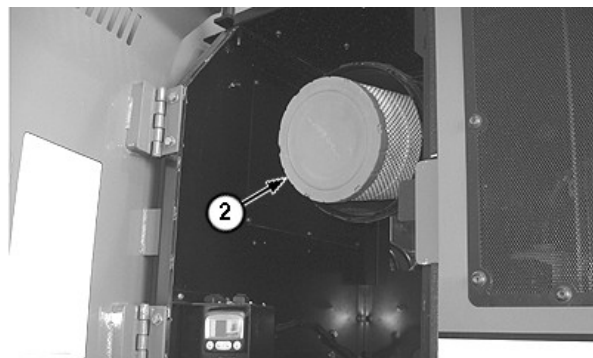

TX1041190A—UN—23APR08

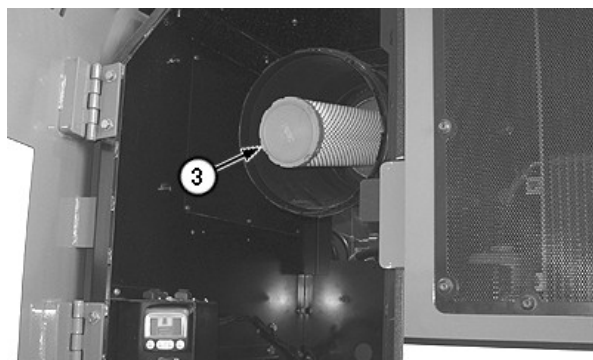

TX1041191A—UN—23APR08

DW90712,0000594-19-05MAR07-1/1

Replace Air Cleaner Dust Unloader Valve

NOTE: A missing, damaged, or hardened dust unloader valve will cause the air filter elements to be ineffective.

Continued on next page

DW90712,0000595-19-03JUN10-1/2

4. Remove rubber pressure release button.
5. Remove cap screw under the pressure release button, and then remove hydraulic tank vent cap filter cover (2) by turning counterclockwise.

6. Remove vent cap filter (3). Install new filter.

IMPORTANT: Do not allow water and/or contaminants to stay between cover (2) and body (4).

7. Install filter cover until it comes in contact with the filter element. Then, further tighten the cover 1/4 turn.

8. Install cap screw, and securely install rubber pressure release button.

- | | |
|--|-------------------|
| 1—Pressure Release Button | 3—Vent Cap Filter |
| 2—Hydraulic Tank Vent Cap Filter Cover | 4—Body |

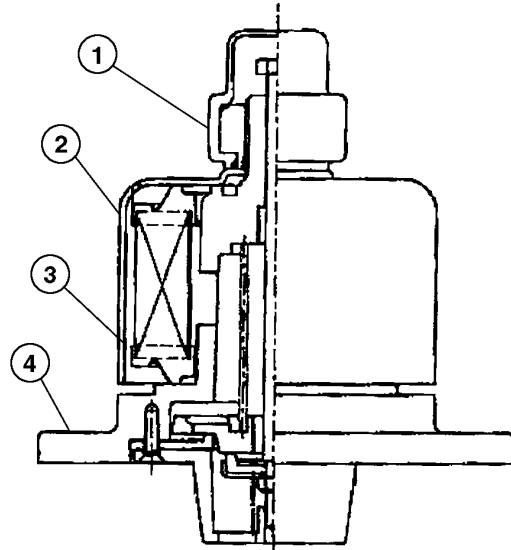

TX1001448—UN—16DEC05

DW90712,00005D9-19-07MAR07-2/2

Replace Engine Crankshaft Damper

The crankshaft damper assembly is not repairable and should be replaced every five years or 5000 hours,

whichever occurs first, or whenever crankshaft is replaced. See an authorized dealer.

DW90712,00005AB-19-23APR15-1/1

4. Use the arrow keys to scroll through the engine configuration data.

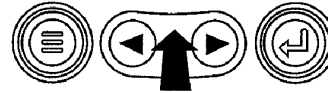
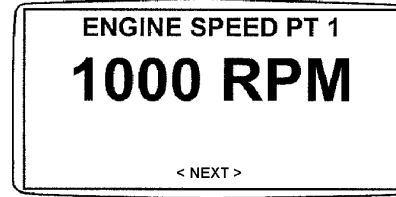

Use Arrow Keys To Scroll

VD76477,00015F2-19-22AUG07-4/6

RG13166—UN—29SEP03

5. Press the menu key to return to the main menu.

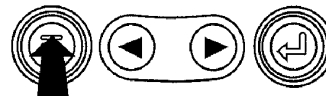
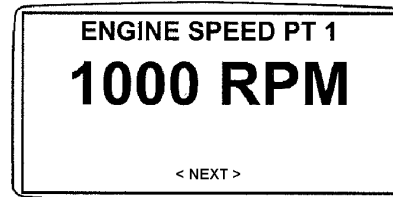

Return To Main Menu

VD76477,00015F2-19-22AUG07-5/6

RG13167—UN—29SEP03

6. Press the menu key to exit the main menu and return to the engine parameter display.

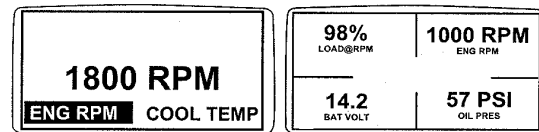

Exit Main Menu

VD76477,00015F2-19-22AUG07-6/6

RG13159—UN—26SEP03

Accessing Stored Trouble Codes

NOTE: The engine does not need to be running to navigate the diagnostic gauge screens. All of the engine values illustrated on the diagnostic gauge indicate the engine is running.

1. Turn the key switch to the ON position. Starting at the single or four engine parameter display, press the menu key.

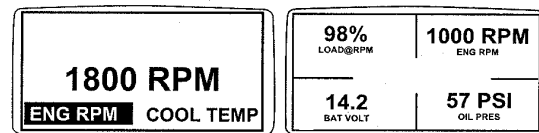

Menu Key

VD76477,00015EE-19-22AUG07-1/6

RG13159—UN—26SEP03

Continued on next page

3. Once Setup 1-Up Display menu item has been highlighted press the enter key to access the Setup 1-Up Display function.

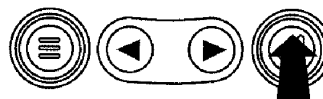
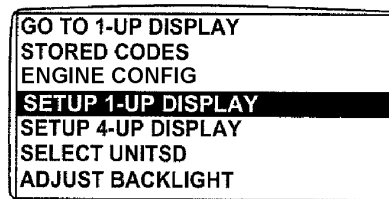

Press Enter Key

VD76477,00015F7-19-22AUG07-3/18

RG13194—UN—02OCT03

4. Three options are available for modification of the 1-Up Display.

- a. **Use Defaults** – This option contains the following engine parameters for display: Engine Hours, Engine Speed, Battery Voltage, % Load, Coolant Temperature and Oil Pressure.
- b. **Custom Setup** – This option contains a list of engine parameters. Engine parameters from this list can be selected to replace any or all of the default parameters. This option can be used to add parameters available for scrolling in the 1-Up Display.
- c. **Automatic Scan** – Selecting the scan function will allow the 1-Up Display to scroll through the selected set of parameters one at a time, momentarily pausing at each.

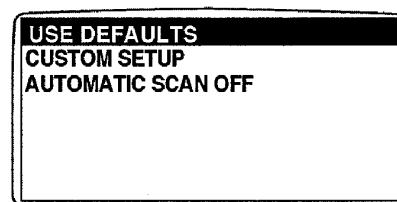

1-Up Display Options

VD76477,00015F7-19-22AUG07-4/18

RG13196—UN—26SEP03

5. **Use Defaults** - To select Use Defaults use the arrow keys to scroll to and highlight Use Defaults in the menu display.

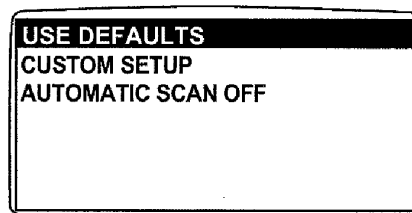

Select Defaults

Continued on next page

VD76477,00015F7-19-22AUG07-5/18

RG13195—UN—26SEP03

Handling, Checking, and Servicing Batteries Carefully

⚠ CAUTION: Battery gas can explode. Keep sparks and flames away from batteries. Use a flashlight to check battery electrolyte level.

Never check battery charge by placing a metal object across the posts. Use a voltmeter or hydrometer.

Always remove grounded (-) battery clamp first and replace it last.

Sulfuric acid in battery electrolyte is poisonous. It is strong enough to burn skin, eat holes in clothing, and cause blindness if splashed into eyes.

Avoid the hazard by:

1. Filling batteries in a well-ventilated area.
2. Wearing eye protection and rubber gloves.
3. Avoiding breathing fumes when electrolyte is added.
4. Avoiding spilling or dripping electrolyte.
5. Use proper jump start procedure.

If you spill acid on yourself:

1. Flush your skin with water.
2. Apply baking soda or lime to help neutralize the acid.
3. Flush your eyes with water for 15—30 minutes. Get medical attention immediately.

If acid is swallowed:

1. Do not induce vomiting.
2. Drink large amounts of water or milk, but do not exceed 1.9 L (2 quarts).
3. Get medical attention immediately.

WARNING: Battery posts, terminals, and related accessories contain lead and lead compounds, chemicals known to the State of California to cause cancer and reproductive harm. **Wash hands after handling.**

If electrolyte spills on the floor, use one of the following mixtures to neutralize the acid: 0.5 kg (1 lb) baking soda in 4 L (1 gal) water, or 0.47 L (1 pt) household ammonia in 4 L (1 gal) water.

IMPORTANT: DO NOT overfill the battery cells.



TS204—UN—15APR13

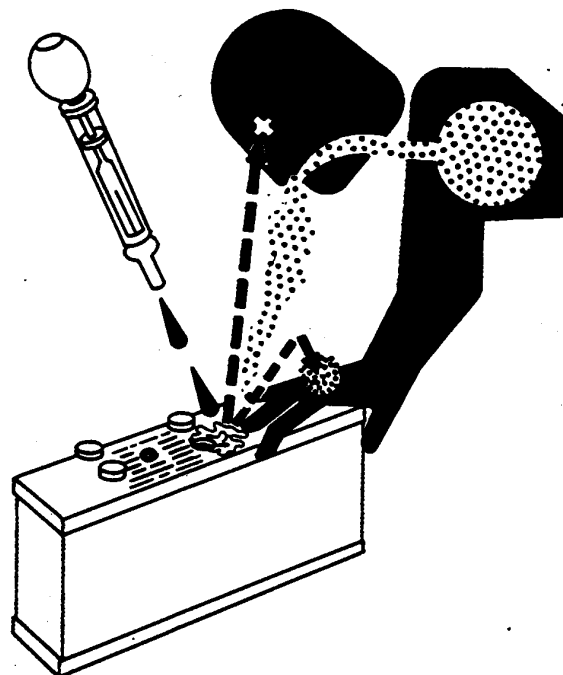

TS203—UN—23AUG88

Check the specific gravity of electrolyte in each battery cell.

Continued on next page

TX03679,0001788-19-12MAR07-1/2

Metric Bolt and Screw Torque Values

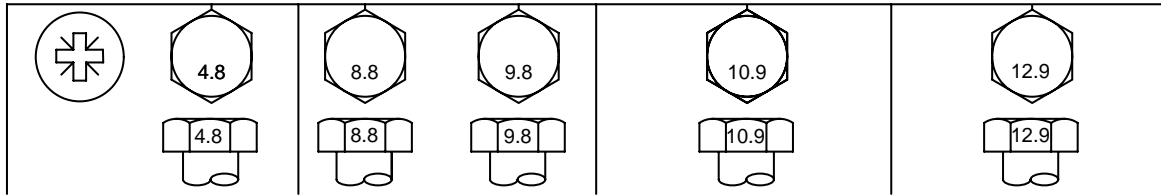

TS1742—UN—31MAY18

Bolt or Screw Size	Class 4.8				Class 8.8 or 9.8				Class 10.9				Class 12.9			
	Hex Head ^a		Flange Head ^b		Hex Head ^a		Flange Head ^b		Hex Head ^a		Flange Head ^b		Hex Head ^a		Flange Head ^b	
	N·m	lb·in	N·m	lb·in	N·m	lb·in	N·m	lb·in	N·m	lb·in	N·m	lb·in	N·m	lb·in	N·m	lb·in
M6	3.6	31.9	3.9	34.5	6.7	59.3	7.3	64.6	9.8	86.7	10.8	95.6	11.5	102	12.6	112
M8	8.6	76.1	9.4	83.2	16.2	143	17.6	156	23.8	17.6	25.9	19.1	27.8	20.5	30.3	22.3
M10	16.9	150	18.4	13.6	31.9	23.5	34.7	25.6	46.8	34.5	51	37.6	55	40.6	60	44.3
M12	—	—	—	—	55	40.6	61	45	81	59.7	89	65.6	95	70.1	105	77.4
M14	—	—	—	—	87	64.2	96	70.8	128	94.4	141	104	150	111	165	122
M16	—	—	—	—	135	99.6	149	110	198	146	219	162	232	171	257	190
M18	—	—	—	—	193	142	214	158	275	203	304	224	322	245	356	263
M20	—	—	—	—	272	201	301	222	387	285	428	316	453	334	501	370
M22	—	—	—	—	365	263	405	299	520	384	576	425	608	448	674	497
M24	—	—	—	—	468	345	518	382	666	491	738	544	780	575	864	637
M27	—	—	—	—	683	504	758	559	973	718	1080	797	1139	840	1263	932
M30	—	—	—	—	932	687	1029	759	1327	979	1466	1081	1553	1145	1715	1265
M33	—	—	—	—	1258	928	1398	1031	1788	1319	1986	1465	2092	1543	2324	1714
M36	—	—	—	—	1617	1193	1789	1319	2303	1699	2548	1879	2695	1988	2982	2199

The nominal torque values listed are for general use only with the assumed wrenching accuracy of 20%, such as a manual torque wrench. DO NOT use these values if a different torque value or tightening procedure is given for a specific application. For lock nuts, for stainless steel fasteners, or for nuts on U-bolts, see the tightening instructions for the specific application.

Replace fasteners with the same or higher property class. If higher property class fasteners are used, tighten these to the strength of the original.

- Make sure that fastener threads are clean.
- Apply a thin coat of Hy-Gard™ or equivalent oil under the head and on the threads of the fastener, as shown in the following image.
- Be conservative with the amount of oil to reduce the potential for hydraulic lockup in blind holes due to excessive oil.
- Properly start thread engagement.

TS1741—UN—22MAY18

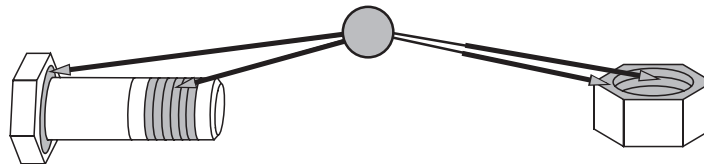

^a Hex head column values are valid for ISO 4014 and ISO 4017 hex head, ISO 4162 hex socket head, and ISO 4032 hex nuts.
^b Hex flange column values are valid for ASME B18.2.3.9M, ISO 4161, or EN 1665 hex flange products.

DX.TORQ2-19-09MAY22-1/1

Monitor and Gauge
Circuit Checks

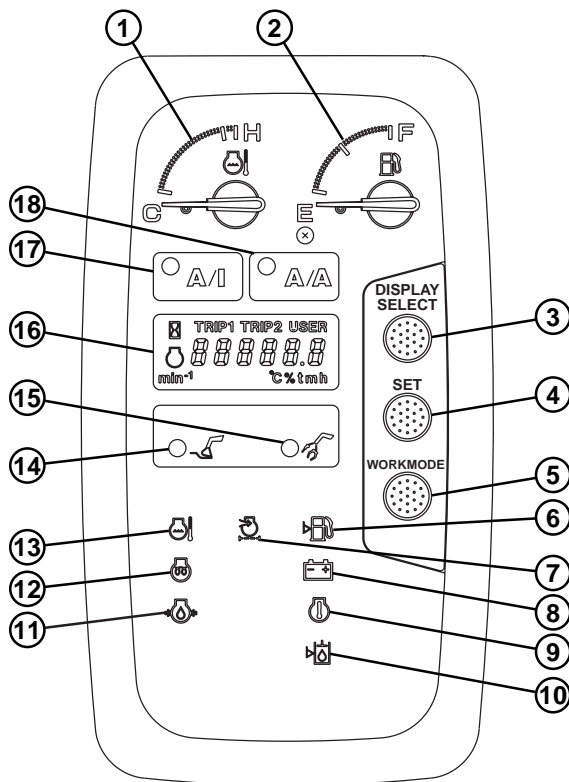

T189029—UN—31MAR03

Monitor Controller and Display

- 1—Engine Coolant Temperature Gauge
- 2—Fuel Gauge
- 3—Display Select Switch
- 4—Set Switch
- 5—Work Mode Switch
- 6—Low Fuel Level Indicator
- 7—Air Filter Restriction Indicator
- 8—Alternator Voltage Indicator
- 9—Check Engine Indicator
- 10—Hydraulic Oil Filter Restriction Indicator
- 11—Engine Oil Pressure Indicator
- 12—Preheat Indicator (not used)
- 13—Engine Coolant Overheat Indicator
- 14—Dig Mode Indicator
- 15—Attachment Mode Indicator (not used)
- 16—Monitor Display
- 17—Auto-Idle Indicator
- 18—Auto-Acceleration Indicator

NOTE: Hydraulic oil filter restriction indicator (10) does not light during bulb check.

IMPORTANT: Prevent possible machine damage from malfunctioning components. Stop the engine if alternator voltage indicator light or engine oil pressure indicator lights do not go OFF or an indicator light comes ON after engine starts.

Start engine.

LOOK: Does alternator voltage indicator (8) display, then go OFF after engine starts?

LOOK: Do all alarm indicators (6—13) remain OFF after engine starts?

LOOK: Does engine coolant temperature gauge (1) display an engine coolant temperature?

LOOK: Does fuel gauge (2) display a fuel level?

YES: Go to next check.

NO: See your authorized dealer.

Continued on next page

OUT4001,000017F-19-16OCT13-18/54

**Disable Travel Function -
Ground Saw Switch
Option**



TX1042932A—UN—26JUN08

Ground Saw Switch

- 1—Rear Work Light Switch
- 2—12 V Power Port (2 available)
- 3—Ground Saw Switch
- 4—Lighter
- 5—Right Rear Speaker

⚠ CAUTION: Prevent possible injury from machine movement. Make sure that area is clear of bystanders and large enough to operate all machine functions.

Engine running.

Place pilot control shutoff lever (1) to UNLOCKED (forward) position.

Move travel lever forward then reverse.

LOOK: Does machine move?

Press ground saw switch (3) on.

Move travel lever forward then reverse.

LOOK: Is the travel function disabled?

YES: Go to next check.

NO: Check ground saw switch 10 A fuse (F54).

NO: See your authorized dealer.

Continued on next page

OUT4001,000017F-19-16OCT13-30/54

**Arm Regenerative Valve
Operation Check**

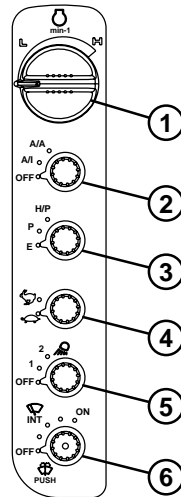

T142011—UN—10MAY01

Switch Panel

- 1—Engine Speed Dial
- 2—Auto-Idle/Auto-Acceleration Switch
- 3—Power Mode Switch
- 4—Travel Speed Switch
- 5—Work Light Switch
- 6—Windshield Wiper and Washer Switch

⚠ CAUTION: Prevent possible injury from machine movement. Make sure area is clear of bystanders and large enough to operate all machine functions.

Turn engine speed dial (1) to H (fast idle) position.

Turn power mode switch (3) to P (standard) mode.

Retract the arm completely and then lower boom so grapple (live heel) is on the ground.

Actuate the boom up and arm out functions in combined operation.

LOOK: Does the arm move smoothly through the complete cycle and not hesitate?

YES: Go to next check.

NO: See your authorized dealer.

Continued on next page

OUT4001,000017F-19-16OCT13-41/54

**Heater and Air
Conditioner Controls
Check—Rear Entry Cab**

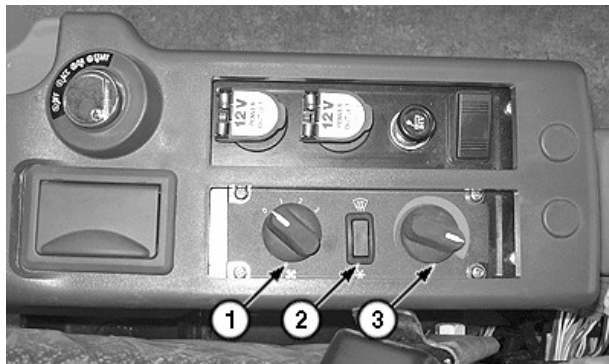

TX1020353A—UN—08MAR07

Heater and Air Conditioner Control Panel

- 1—Fan Speed Switch**
- 2—Defrost/Air Conditioner Switch**
- 3—Temperature Control Dial**

Engine running and at normal operating temperature.

Turn fan speed switch (1) to “1” slow position.

LISTEN/FEEL: Does the fan operate in slowest speed?

Turn fan speed switch to “2” medium position.

LISTEN/FEEL: Does fan operate faster than slow speed?

Turn fan speed switch to “3” fast position.

LISTEN/FEEL: Does the fan operate in fastest speed?

With fan running at any speed, switch the defrost/air conditioner switch (2) to defrost position. Turn temperature control dial (3) to “red” position.

LISTEN/FEEL: Does warm air exit from vents next to the windows?

With fan running at any speed, switch the defrost/air conditioner switch to off (center) position. Turn temperature control dial to “red” position.

FEEL: Does warm air exit from vents?

With fan running at any speed, switch the defrost/air conditioner switch to the A/C (snowflake) position. Turn temperature control dial to “blue” position.

FEEL: Does cold air exit from vents?

YES: Go to next check.

NO: Check heater and air conditioner 5 A fuse (F7) (marked AIRCON) and heater and air conditioner 20 A fuse (F13) (marked HEATER).

NO: See your authorized dealer.

Continued on next page

OUT4001,000017F-19-16OCT13-52/54

Hydraulic System

Symptom	Problem	Solution
No Hydraulic Functions	Pilot Shutoff Lever	Place pilot shutoff in UNLOCKED (forward) position.
	Low hydraulic oil	Add oil.
	Clogged suction filter	Clean.
Hydraulic Functions Are Slow or Have Little or No Power	Low oil level	Fill hydraulic oil tank to full mark.
	Cold oil	Perform cold weather warm-up.
	Incorrect oil	Use correct oil.
	Suction screen clogged	Inspect and clean.
	Hydraulic tank cap/cover	Replace cap/cover.
Ground Saw Does Not Work	Fuse	Check ground saw 10A fuse F54.
	Switch	See your authorized dealer.
	Connector	Clean contacts, reconnect.
	Wiring	See your authorized dealer.
	Ground saw pilot circuit	See your authorized dealer.
Power Boost Does Not Work	Fuse	Check pump and valve controller 5A fuse (marked CONTROLLER) and solenoid 10A fuse (marked SOLENOID) fuse.
Hydraulic Oil Overheats	Incorrect oil	Use correct oil.
	Clogged radiator or oil cooler	Clean and straighten fins.
	Radiator screen clogged	Clean screen.
	Clogged filters	Install new filters.
	Low oil level	Fill tank to full mark.
	Contaminated oil	Drain oil and refill.
Oil Foams	High or low oil level	Correct level.
	Incorrect oil	Use correct oil.
	Water in oil	Change oil.
	Kinks or dents in oil lines	Check lines.
No Swing Function	Pilot control hoses pinched or kinked	Inspect and correct.
Swing Function Is "Jerky"	Lack of grease	Fill with grease

Continued on next page

OUT4001,00001BE-19-27JUN08-1/2

2154D Log Loader Fixed Heel Grapple Machine Specifications

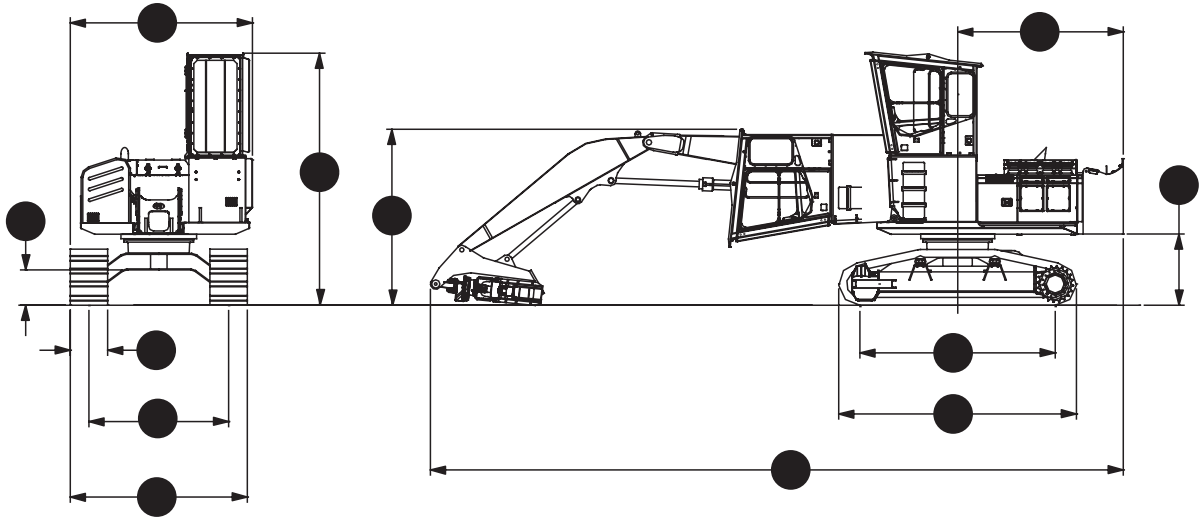

TX1044427

TX1044427—UN—30JUN08

- | | | | |
|-------------------------------------|---------------------------------------|------------------------|------------------------|
| 1—Overall Length | 3—Distance Between Idler and Sprocket | 6—Upperstructure Width | 10—Ground Clearance |
| 2—Rear-End Length/Tail Swing Radius | 4—Undercarriage Length | 7—Transport Height | 11—Undercarriage Width |
| | 5—Counterweight Clearance | 8—Track Width | 12—Cab Height |
| | | 9—Gauge Width | |

NOTE: Specifications and design subject to change without notice. Wherever applicable, specifications are in accordance with SAE standards. Except where otherwise noted these specifications are based on a machine equipped with 1818-lb (840 kg) full fuel tank; 175-lb (79 kg) operator; 11,490-lb (5212 kg) counterweight; 1,800-lb (816 kg) grapple and 28-in. (700 mm) double-grouser shoes and standard equipment.

Item	Measurement	Specification
1—Overall Length	Length	12.98 m 47 ft 7 in.
2—Rear-End Length	Distance	3.10 m 10 ft 2 in.
2—Tail Swing Radius	Distance	3.15 m 10 ft 4 in.
3—Distance Between Idler/Sprocket	Distance	3.66 m 12 ft 0 in.
4—Undercarriage Length	Length	4.45 m 14 ft 7 in.
5—Counterweight Clearance	Distance	1.33 m 4 ft 4 in.
6—Upperstructure Width / with 48 in. Side Entry Cab	Width	3.41 m 11 ft 2 in.

Continued on next page

OUT4001,0000183-19-19JUN08-1/2

EC Declaration of Conformity

Deere & Company
Moline, Illinois U.S.A.

The person named below declares that

Machine type: Log Loader

Model: 2154D with a Waratah Processing Head, Log loader Grapple, or Excavator-type Bucket/Attachment

fulfills all relevant provisions and essential requirements of the following directives:

Directive	Number	Certification Method
Machinery Directive	2006/42/EC	Self certified, per Annex V of the Directive
Electromagnetic Compatibility (EMC)	2004/108/EC	Self certified, per Annex II of the Directive
Physical Agents (Vibrations)	2002/44/EC	Self certified - instructions only
Physical Agents (Noise)	2003/10/EC	Self certified - instructions only
Engine Emissions	97/68/EEC & 2004/26/EC	Notified Body

Name and address of the person in the European Community authorized to compile the technical construction file:

Brigitte Birk
 Deere & Company European Office
 John Deere Strasse 70
 Mannheim, Germany D-68163
 EUConformity@johndeere.com

Place of declaration: Langley,
 British Columbia Canada

Date of declaration:

Manufacturing unit:

Name: Mike Schlender

Title: Operations Manager

Deere Hitachi Specialty Products, Langley, British Columbia

DXCE01—UN—28APR09



JH91824,00008BA-19-09AUG13-1/1

CLICK HERE TO **DOWNLOAD** THE COMPLETE MANUAL

- Thank you very much for reading the preview of the manual.
- You can download the complete manual from: www.heydownloads.com by clicking the link below



- Please note: If there is no response to CLICKING the link, please download this PDF first and then click on it.

CLICK HERE TO **DOWNLOAD** THE COMPLETE MANUAL