

# 1710D Forwarder Serial Number WJ1710D000481-

## OPERATOR'S MANUAL 1710D Forwarder

OMF065851 Issue 13th of November 2003  
(ENGLISH)

CALIFORNIA  
Proposition 65 Warning

Diesel engine exhaust and some of its constituents are known to the State of California to cause cancer, birth defects, and other reproductive harm.

If this product contains a gasoline engine:

 **WARNING**

The engine exhaust from this product contains chemicals known to the State of California to cause cancer, birth defects or other reproductive harm.

The State of California requires the above two warnings.

CLICK HERE TO **DOWNLOAD** THE COMPLETE MANUAL

- Thank you very much for reading the preview of the manual.
- You can download the complete manual from: [www.heydownloads.com](http://www.heydownloads.com) by clicking the link below



- Please note: If there is no response to CLICKING the link, please download this PDF first and then click on it.

CLICK HERE TO **DOWNLOAD** THE COMPLETE MANUAL

# Warranty

## Standard warranty clauses

The machine is covered by Timberjack's guarantee in compliance with the standard warranty clauses accepted by the Timberjack group.

The manufacturer will not assume responsibility for the machines delivered should the following conditions be violated:

- The forwarder is exclusively operated and maintained by experienced personnel who have been trained by Timberjack or by a dealer authorized by Timberjack.
- The forwarder must be operated and maintained in accordance with the instructions provided in this manual.
- Only fuels and lubricants specified in this manual are used.
- Only genuine spare parts are used

EL62757,000015D -19-19APR02-1/1

## 250 and 1000 Hours Service

The forwarder was checked and test driven before delivery, and it can be put to use immediately. However, to ensure good reliability it is very important to thoroughly service the machine once it has been put to use.

The warranty given by Timberjack will be valid provided that the machine is handed over for after sales maintenance at 250 and 1000 running hours, the service shop being one authorized by Timberjack.

Naturally the validity of warranty requires that during the warranty period all the maintenance procedures have to be performed according to the maintenance intervals detailed in this manual.

EL62757,000015E -19-19APR02-1/1

## Handle Starting Fluid Safely

**CAUTION:** Never use a liquid starting aid, if engine is equipped with the pre-heat device. The use with the pre-heat device will cause an explosion in the intake manifold.

Starting fluid is highly flammable.

Keep all sparks and flame away when using it. Keep starting fluid away from batteries and cables.

To prevent accidental discharge when storing the pressurized can, keep the cap on the container, and store in a cool, protected location.

Do not incinerate or puncture a starting fluid container.



TS1356 -UN-18MAR92

OUTJ003,000068F -19-14MAY01-1/1

## Pay Attention to Bystanders

Keep windows clean and the cab floor free from loose articles.

Keep the door closed when driving the machine. Do not operate the machine with any of the safety covers or protective devices removed.

Always keep the reverse warning alarm (if equipped) in working condition.

Use a signal person when moving the machine in congested areas (for example indoor service shop)  
Coordinate hand signals before starting the machine.

The machine must not be operated by anyone under the influence of alcohol or drugs.

Avoid using the machine when you are tired or ill, as there is a greater risk of accident. Take sufficient breaks and observe local regulations on working hours.

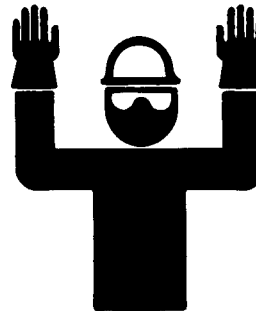

T6964AD -UN-20DEC88

TX,05,FF3319 -19-08FEB93-1/1

## Use Proper Tools

Use appropriate and correct size tools. Makeshift tools and procedures can create safety hazards or cause machine damages.

Illuminate your work area and service points adequately. Secure that portable light has a bulb enclosed by a wire cage. The hot filament of an accidentally broken bulb can cause a risk of fire.

Use power tools only to loosen threaded parts and fasteners. DO NOT use U.S. measurement tools on metric fasteners.

Keep tools clean. Avoid bodily injury caused by slipping wrenches.

Repair or replace worn or damaged tools, before initiating repair work on your machine.

Use only service parts meeting manufacturer's specifications.



TS779 -UN-08NOV89

OUTJ003,00005AB -19-09MAY01-1/1

## Support Machine Properly

Use proper lifting equipment. Lifting heavy components incorrectly can cause severe injury or machine damage.

Follow recommended procedure for removal and installation of components in the manual. Make sure that jack stands and lifting equipment are in good condition and of adequate capacity.

Do not work under a machine that is supported solely by a jack. If left in a raised position, hydraulically supported devices can settle or leak down.

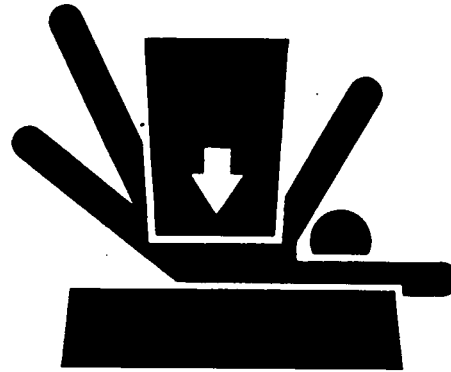

TS229 -UN-23AUG88

AK12300,000004F -19-28FEB02-1/1

### Front Dashboard

- 1—Hazard lights
- 2—Horn
- 3—In reserve
- 4— Stairs
- 5—In reserve
- 6—Rear wheel drive; engagement (when high gear is on)
- 7—Windscreen washer \*
- 8—Windscreen wiper \*
- 9—Left side window wiper \*
- 10—Right side window wiper\*
- 11—Rear window washer
- 12—Rear window wipe \*
- 13—Emergency stop
- 14—Cigarette lighter (24 V)
- 15—Ignition switch
- 16—In reserve
- 17—Decking blade float<sup>1</sup>
- 18—Head lamp; high beam/low beam
- 19—Switch, headlights
- 20—Turn indicator lights
- 21—Ministick steering on/off; opt. eq
- 22—In reserve
- 23—Parking brake

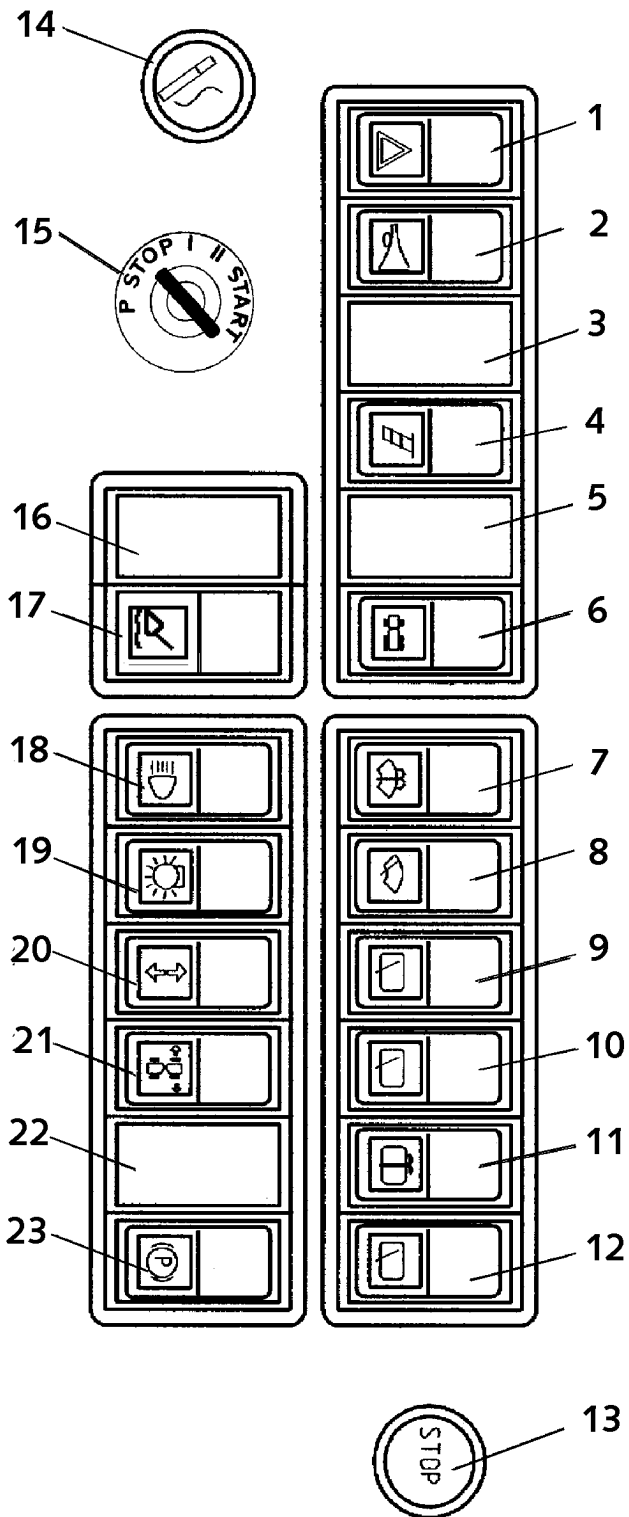

T152191 -JUN-19AUG03

<sup>1</sup>See: Equipment, Decking blade

## **Alarms**

The TMC™ control system is equipped with a condition-monitoring system that greatly facilitates the use and maintenance of the system. The alarms are recorded in the alarm log.

The alarms are registered in ECU but they can be glanced only in TMC.

There are two kind of alarms: active and previous active (see the TMC manual<sup>1</sup> attached).

<sup>1</sup>See alarms -section in TMC manual.

# Transportation of the Machine

## Use hold-down straps

Make sure that the tracks, fuel container, and other loose items on the load area of the machine are properly secured for the transport (use heavy-duty hold-down straps, for instance).

EL62757,0000189 -19-21APR02-1/1

## Positioning

When positioning the forwarder onto the trailer, ensure that the machine is laterally as well centered as possible. Similarly, when positioning the machine and the boom bear in mind the maximum axle loads permitted for the truck or trailer as well as the maximum width and height. If necessary, the values must be checked by measuring before transporting.

EL62757,000018A -19-21APR02-1/1

## Minilevers

For the transport minilevers are clamped to the extreme position with rubber loops situated on outer side of control panels.

EL62757,000018B -19-21APR02-1/1

T152215 -UN-05MAR02

2. Engage the high gear (the driving direction switch has to be in neutral position).
3. Select the driving direction with the direction switch
4. Press the pedal, which will automatically disengage the work brake. The machine will start moving.
5. The speed of the machine is regulated by means of the accelerator pedal. This will simultaneously adjust the diesel engine speed and the gear ratio of the hydrostatic system.



EL62757,0000193 -19-21APR02-2/3

6. The adjustable speed range (%) can be used as when driving off-road.
7. When driving on road the machine is steered with
  - The ministick
  - A hydraulic stick (optional equipment)

*NOTE: There are countries where the use of the ministick for driving on public roads (with the high gear engaged) is forbidden (Germany) or blocked (Sweden) because of road traffic regulations*

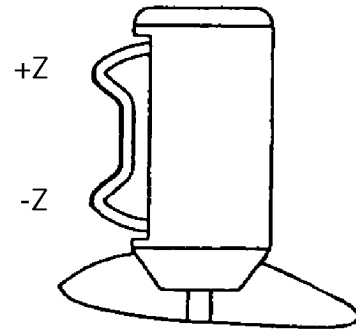
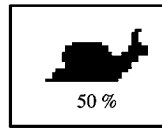

T152214 -UN-05MAR02

8. Before you embark on driving on public roads, remember the following:
  - Install the rear lights and front turn indicators and check their function.
  - Adjust the side-view mirrors

EL62757,0000193 -19-21APR02-3/3

## Cleaning the Cab Windows

### 1. General cleaning

Wash the windows with lukewarm water and a mild, neutral, liquid detergent. Rinse well with clean water. Dry thoroughly to avoid water marks, using a soft and clean cloth

### 2. Cleaning vehicle windows during operation

Always spray the window before wiping. Thoroughly spray the window so that the wipers do not run dry. Ensure that the window washer bottle is topped up frequently with a mixture of water and window wash fluid.

### 3. Removing stains

Remove stains of resin, paint, grease, oil, etc, before the stain has time to dry.

Use a soft cloth moistened with one of the following approved solvents.

- Pure isopropyl alcohol, IPA
- White spirit
- Heptane
- Light petroleum
- Butyl ethyl glycol
- Methanol
- Hexane
- Butanol

After removing stains, wash the window as described above

EL62757,00000A7 -22-19OCT02-1/1

**Coolant**

Capacity	Engine cooling system	27 l (7,1 gal)
----------	-----------------------	-------------------

The engine cooling system is filled to provide year-round protection against corrosion and cylinder liner pitting, and winter freeze protection to -37°C (-34°F).

Use a coolant mixture consisting of 50 percent of water and 50 percent of antifreeze in the system all year round. The antifreeze must consist of ethylene glycol or propylene glycol and that complies with grade ASTM4985 or ASTM5345.

Coolant chart	
Antifreeze, in percents	Freezing point of volume, °C
40	-24 (-11 °F)
50	-37 (-34 °F)
60	-52 (-61 °F)

The anti-freezing ability will be reduced if the content of glycol is greater than 60%.

If it is necessary to add coolant to the system make sure that the new coolant is similar to the original. Allow the engine to cool down before adding new coolant.

Check the coolant concentration before the ambient temperature drops below 0°C (32°F).

EL62757,0000153 -19-18APR02-1/1

### Check the windshield washer fluid level

The windshield washer tank is located in the engine compartment. Ensure that there is enough of the fluid.

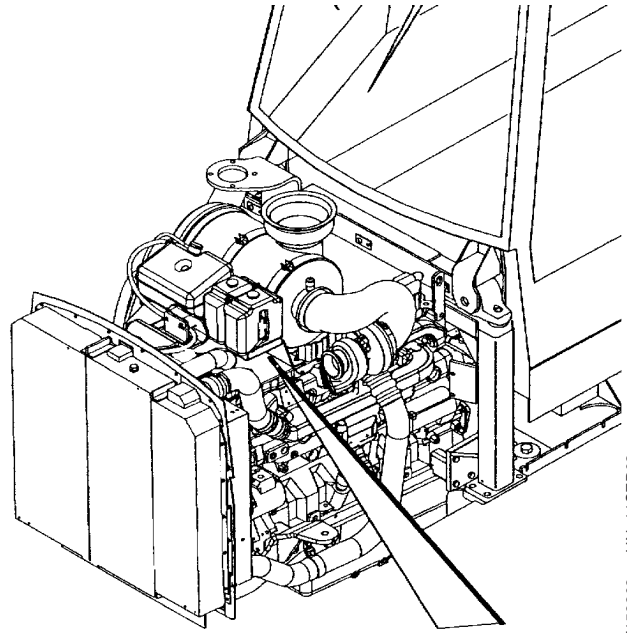

T159303 -UN-11SEP02

EL62757,00000F6 -19-10APR02-1/1

## Check Single Axle Wheel Ends ( Hub gear) Oil Level

*NOTE: Although oil can pass from the differential to the wheel ends, it is necessary to check the oil level in the differential and each wheel end separately.*

1. Position the wheel end so that the drain port (1) is on the horizontal centerline of the axle.
2. Remove the drain plug. The oil level must be up to the drain port.
3. Add oil, if necessary, through the fill port (2).
4. Install the drain plug.

*NOTE: Any time a plug is removed, replace the O-ring seal or copper washer.*

Capacities	Hub gears, 6-wheel	2 x 5 l (2 x 1.3 gal)
Hypoid oil	API GL-5 or MIL-L-2105 B or D	
Viscosity	SAE 90 SAE 85W/90 SAE 80W/90 SAE 75W/90	

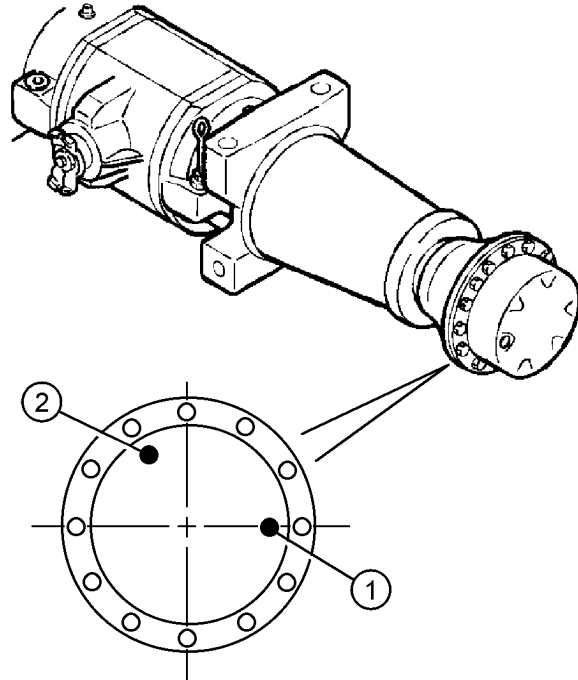

1—Drain Plug  
2—Fill Plug

T144162 -UN-19JUL01

OUTJ003,00006F6 -19-17JUL01-1/1

## Checking belt tensioner spring tension and belt wear

Belt drive systems equipped with automatic (spring) belt tensioners cannot be adjusted or repaired. The automatic belt tensioner is designed to maintain proper belt tension over the life of the belt. If tensioner spring tension is not within specification, replace tensioner assembly.

EL62757,000010F -19-10APR02-1/4

### Checking belt wear

The belt tensioner is designed to operate within the limit arm movement provided by the cast stops (A and B) when correct belt length and geometry is used.

Visually inspect cast stops (A and B) on belt tensioner assembly.

If the tensioner stop (A) on swing arm is hitting the fixed stop (B), check mounting brackets (alternator, belt tensioner, idler pulley, etc.) and the belt length. Replace belt as needed.

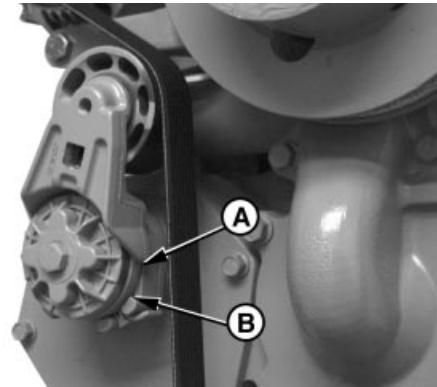

RG7380 -UN-28NOV97

Belt Tensioner

A—Tensioner Stop  
B—Fixed Stop

EL62757,000010F -19-10APR02-2/4

### Checking tensioner spring tension

A belt tension gauge will not give an accurate measure of the belt tension when automatic spring tensioner is used. Measure tensioner spring tension using a torque wrench and procedure outlined below:

1. Release tension on belt using a long-handle 1/2 inch breaker bar in tension arm. Remove belt from pulleys.
2. Release tension on tension arm and remove breaker bar
3. Put a mark (A) on swing arm of tensioner as shown.
4. Measure 21 mm (0.83 in.) from mark (A) and put a mark (B) on tensioner mounting base.

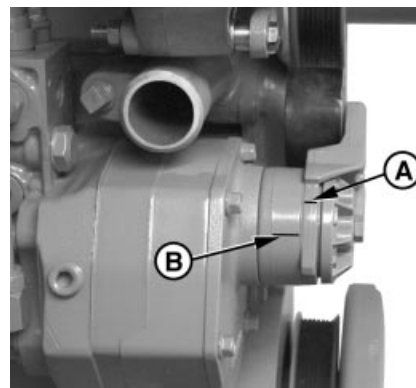

RG7382 -UN-28NOV97

Checking Belt Tension Spring

A—Mark  
B—Mark

Continued on next page

EL62757,000010F -19-10APR02-3/4

## Renew the high/low gear (transfer case) oil

1. Park machine on a level surface. Lower decking blade to the ground and secure grapple to Rear frame.
2. Engage park brake. Turn key switch OFF.

**CAUTION:** Prevent possible injury from unexpected machine movement. Install frame locking bar before working in frame pivot area.

3. Install frame locking bar.
4. To access the bottom of the transfer case, remove the cover on the underside of the front frame.
5. Remove the drain plug (3) and drain the transfer case oil into a suitable container.

*NOTE: Dispose of waste properly.*

6. After draining, install the plug and replace the access cover.
7. Add oil through the plug (2).

*NOTE: To vent transfer case while adding oil, pull up dipstick.*

8. Check oil level on dipstick. Oil level must be at the FULL notch.
9. Install fill plug.

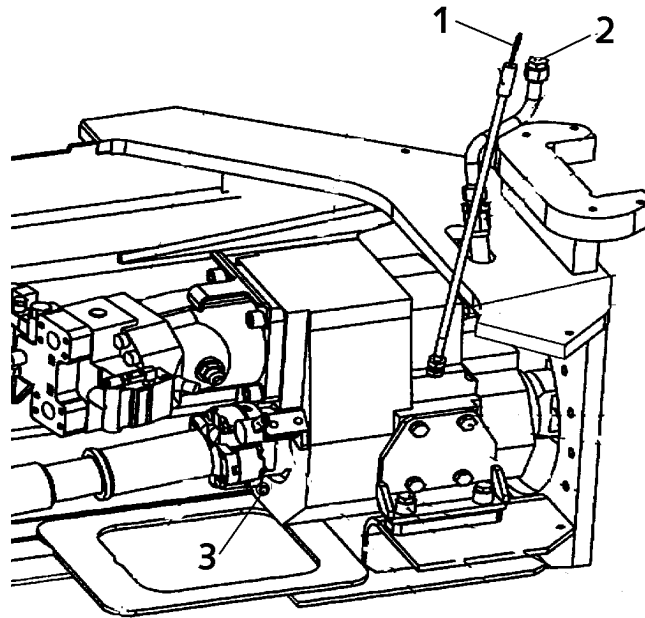

T165055 -UN-06FEB03

Capacities	High / low gear	4.8 l (1.3 gal)
Hypoid oil	API GL-5 or MIL-L-2105 B or D	
Viscosity	SAE 90 SAE 85W/90 SAE 80W/90 SAE 75W/90	

EL62757,000011E -19-10APR02-1/1

## Change Bogie Housings Oil

**NOTE:** Before changing the bogie housing oil, let the machine stand for 30 minutes to allow impurities to settle to the bottom.

1. Park the machine on a level surface. Engage the parking brake. Install the frame lock.
2. Clean the area around the plugs.
3. Remove the filler plug to vent the bogie housing.
4. Remove the inspection plug.
5. Remove the drain plug. Drain oil into a suitable container.

**NOTE:** Dispose of waste properly. Do not dump oil on ground or in sewers.

6. Install the drain plug. Add oil to the bogie housing through the filler port until the oil level is up to the inspection port.
7. Install the filler and inspection plugs.

**NOTE:** Any time plugs are removed, the O-ring seals should be replaced.

8. Repeat the procedure at each bogie.

Capacities	Bogie housing	65 l (17.2 gal)
Hypoid oil	API GL-5 or MIL-L-2105 B or D	
Viscosity	SAE 90 SAE 85W/90 SAE 80W/90 SAE 75W/90	

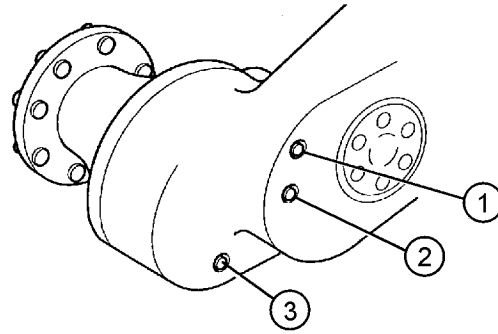

1—Filler Plug  
2—Inspection Plug  
3—Drain Plug

T142919 -UN-13JUN01

OUTJ003,00006B8 -19-16MAY01-1/1

Loosen fuel pump low pressure outlet line (A) (outboard lower line of fuel pump). Unlock and pump hand primer (B) until primary filter bowl is full of fuel and all air is bled from the line (Must pull hand primer all the way up between pump's). Tighten outlet line to specification below:

**Specification**

Low Pressure Outlet Line—  
Torque ..... 27 N•m (20 lb-ft)

3. Connect JT03472 coupler and hose to diagnostic port (D). If JT03472 coupler is not available, loosen the diagnostic port to allow air and fuel to escape. Bleed fuel into suitable container. Tighten diagnostic port to specification below.

**Specification**

Diagnostic Port—Torque ..... 14 N•m (10 lb-ft)

4. Loosen high pressure fuel lines (E). Pump hand primer (B) until steady flow of fuel escapes the fuel pump. Tighten fuel lines to specification below and lock hand primer (pull up, then push down and lock).

**Specification**

High Pressure Fuel Lines—  
Torque ..... 27 N•m (20 lb-ft)

5. Start engine. If engine will not start, do NOT crank for more than 30 seconds. Repeat step 4.  
6. Once engine starts, run at 1200-1500 RPM for 3-5 minutes.

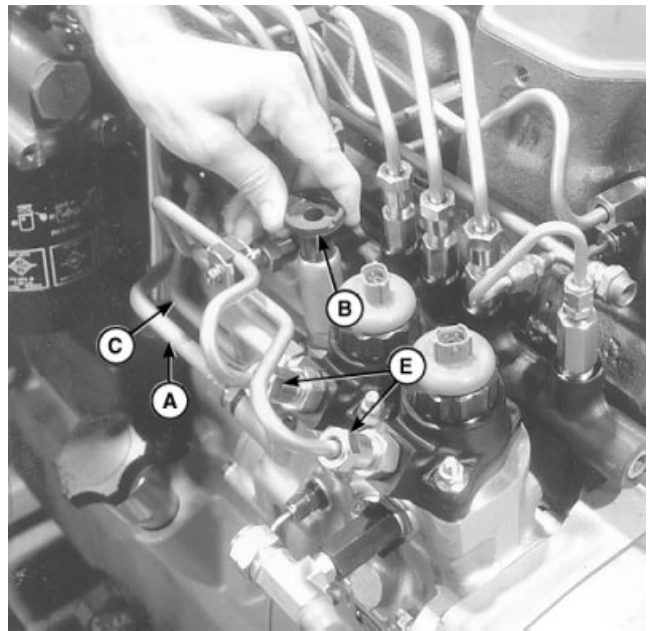

RG11600 -UN-11DEC00

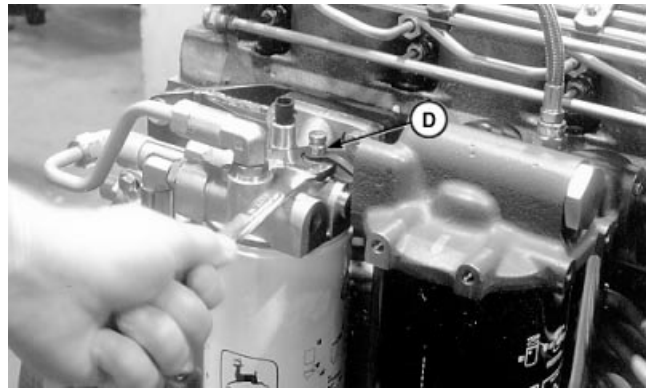

RG11599 -UN-11DEC00

- A—Low Pressure Outlet Line
- B—Hand Primer
- C—Low Pressure Inlet Line
- D—Diagnostic Port
- E—High Pressure Fuel Lines

RG41221,0000001 -19-18DEC00-2/2

**Have the proper function of the turbocharger checked**

Let an authorized service person do this check.

EL62757,00000F0 -19-10APR02-1/1

**Have the proper function of the alternator checked**

Let an authorized service person do this check.

EL62757,000012A -19-10APR02-1/1

## Renew the hydraulic oil.

*NOTE: Change hydraulic oil when it is warm and contaminants are in suspension.*

### Draining the oil

The oil tank drain hose (1) is located at the front belly pan.

1. Open the plug at the end of the drain pipe
2. The hydraulic oil of the working hydraulic pump is drained by opening the plug (2) at the end of the drain pipe

*NOTE: Dispose of waste properly.*

3. Clean the hydraulic tank.
4. After every 1000 hours: change the hydraulic return filter and the breather. See section 6-6.
5. Close the plug of the drain pipe.

### Filling the oil

**IMPORTANT: Do not exceed the 'MAX' mark.**

**There always has to be enough air space in the hydraulic oil tank, because the fluid level goes up and down during the operation.**

**IMPORTANT: Do not mix different type of oils.**

Add oil through the quick coupler (4) with the hydraulic fill-up pump (3) (optional equipment). The quick coupler is mounted in a way that the new oil enters the system through the filter.

*NOTE: During the fill up, open the vent tap of the hydraulic tank.*

1. Clean the filling hose and remove the dust cap.
2. Place the hose into the canister containing new hydraulic oil.
3. Start the filling pump with switch (3).
4. Close the vent tap.

*NOTE: Also a manual pump can be used.*

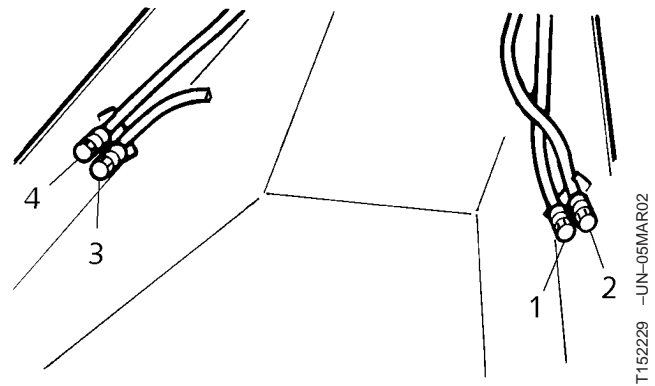

1—Drain hose, hydraulic oil from the tank  
2—Drain hose, hydraulic oil from work pump

T152229 -JUN-05MAR02

### Checking and adjusting the pressure cut-off valve setting of the drive pump

1. Disconnect the parking brake solenoid Y41 from the valve block . After this, the parking brake will stay engaged.
2. Connect pressure gauges (60 MPa) (8702 psi) to measuring points (214) (forward) and (206) (reverse).
3. Engage high gear.
4. Drive the machine both forward and backward even though the brake is on. Do not do this longer than for five seconds at a time.
5. The pressure should rise to  $43.0 + 0.5$  MPa ( $6234 + 72$  psi) (both directions).
6. If necessary, adjust the pressure with adjusting screw (210) (forward/reverse).
7. After making the adjustment, check the pressures once again.
8. Fit the solenoid into the valve and tighten the lockscrew hand tight.

(206)—Measure point, drive pressure backwards  
 (210)—Adjust screw  
 (214)—Measure point, drive pressure backwards

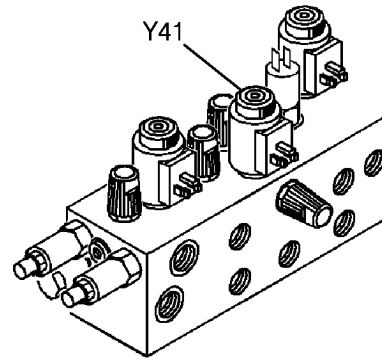

T138248 -UN-22AUG01

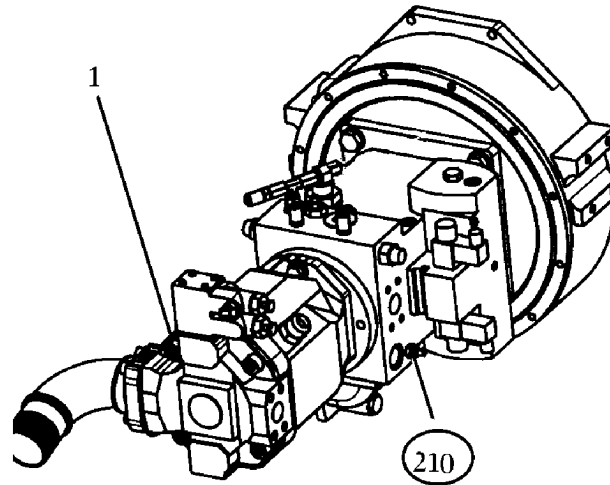

T153142 -UN-28MAR02

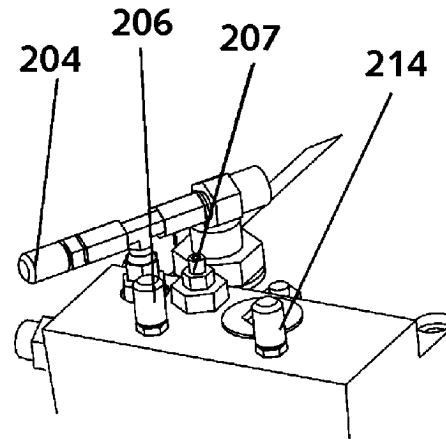

T153143 -UN-19FEB03

## Mechanical adjustment of brakes

1. Disconnect electrical contact Y41W, from the work brake valve.
2. Remove the protective cover (2). Note the loose release screw (3) under the cover
3. Open the larger Allen screws (5) (4 screws, key size 8 mm) and remove the cylinder.

**NOTE:** The smaller Allen screws (2 screws, key size 6 mm) should not be loosened

4. Loosen the locking nut (4). Hold the piston (6) in position.
5. Fully open the adjusting screw (1). Clean the thread and the locking nut (4).
6. Turn the locking nut (4) to the end of the adjusting screw. Lock the adjusting screw thread (1) by applying locking fluid (Loctite 242).

**NOTE:** If the locking fluid comes into contact with other areas than the adjusting screw and the locking nut, the excess fluid should be cleaned away.

7. Insert the adjusting screw (1) and turn it clockwise until a significant resistance is felt (8...15 Nm) (5,9...11 lb-ft). Turn the adjusting screw (1) 3 1/2 turns counterclockwise while holding the piston (6) in position.
8. Tighten the locking nut (4) to approx. 40 Nm (29.5 lb-ft) while holding the piston (6) in position.
9. Reinstall the cylinder. Ensure that the O ring (7) is in good condition and is correctly positioned. Tighten the four screws (5).
10. Fit the protective cover (2). Check that the O ring is in good condition and is correctly positioned
11. Connect the electrical contact Y41W to the brake valve. Adjust all the cylinders in the same way

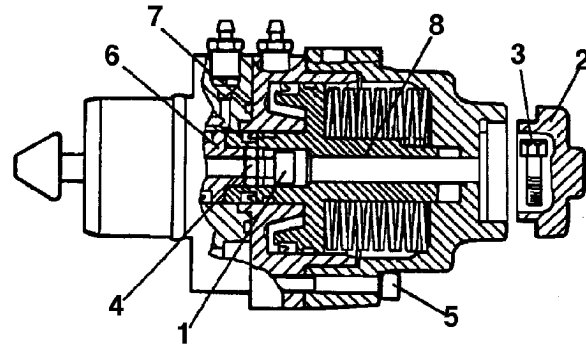
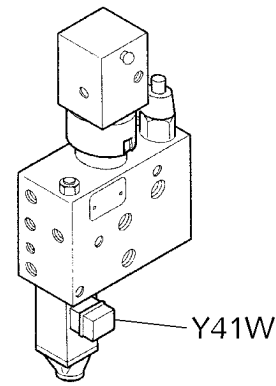

T152220 -JUN-05MAR02

T153523 -JUN-04APR02

EL62757,00001A8 -19-21APR02-1/1

CLICK HERE TO **DOWNLOAD** THE COMPLETE MANUAL

- Thank you very much for reading the preview of the manual.
- You can download the complete manual from: [www.heydownloads.com](http://www.heydownloads.com) by clicking the link below



- Please note: If there is no response to CLICKING the link, please download this PDF first and then click on it.

CLICK HERE TO **DOWNLOAD** THE COMPLETE MANUAL

### Instrument Box Fuses and Relays

F1-F13	Work Lights
F14	Head light switch
F15	Ignition
F16	Parking lights
F17	Brake switch
F18	Air conditioner, Seat compressor (opt. eq.)
F19	Horn
F20	Indicator lights
F21	TMC
F22	Windscreen wipers
F23	Cigarette lighter
F24	Stairs
F25	Vacuum pump
F26	ECU
F27	Rear window wipers
F28	Fuel valve, stopping solenoid, motor ECU
F29	Air conditioner, valve (opt. eq.)
F30	Hydraulics vacuum pump , (opt. eq.)
F31	Low beam
F32	Voltage transformer
F33	High beam
F34	Parking brakes
F35	Parking brakes
F36	Working pump's drop
K1	Electricity controlled by ignition switch
K2	Intermittent rear window wiper
K4	Blinker relay
K6	Seat compressor
K9	Hourmeter
K12	Intermittent windshield wiper
K14	Engine starting prevent
K20	Radio
K21	Pressure switch, Air conditioner, compressor (opt. eq.)
K22	Air conditioner, (opt. eq.)
K23	Seat compressor

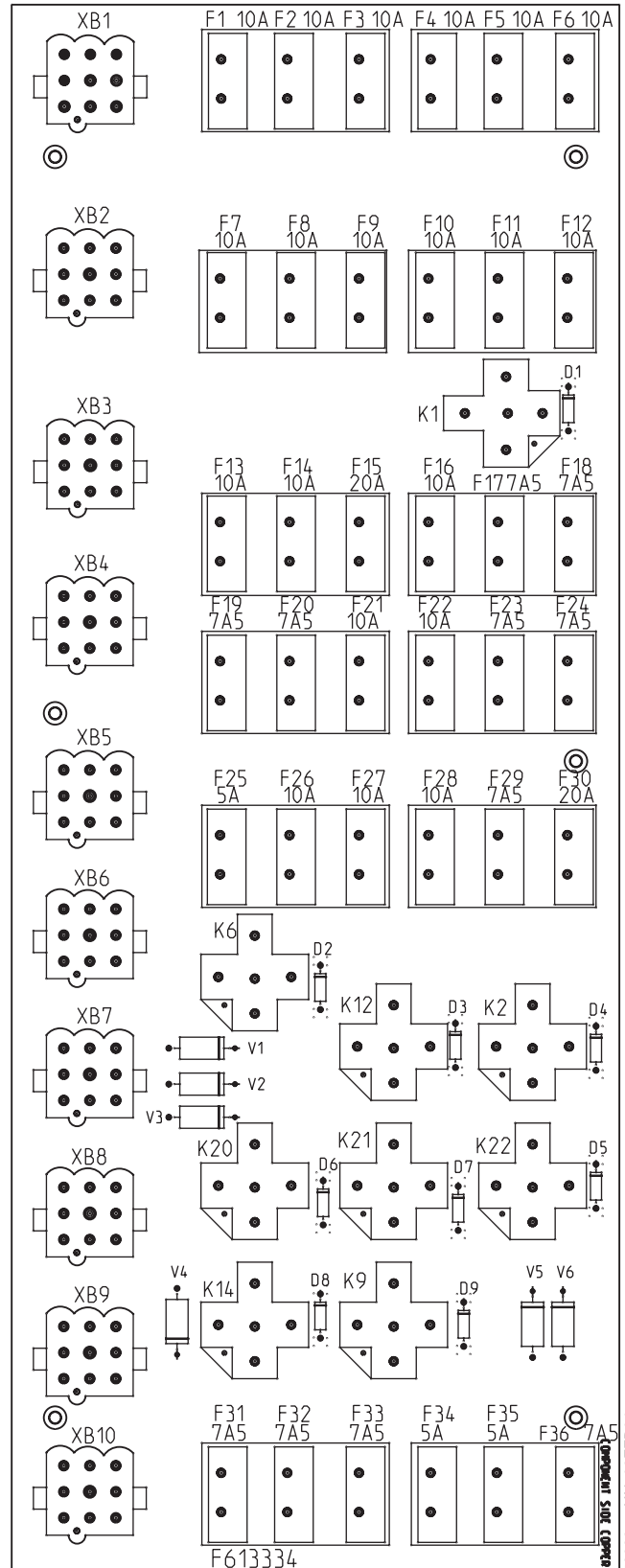

Continued on next page

EL62757,00001B2 -19-21APR02-1/2

# Engine Control Unit (ECU)

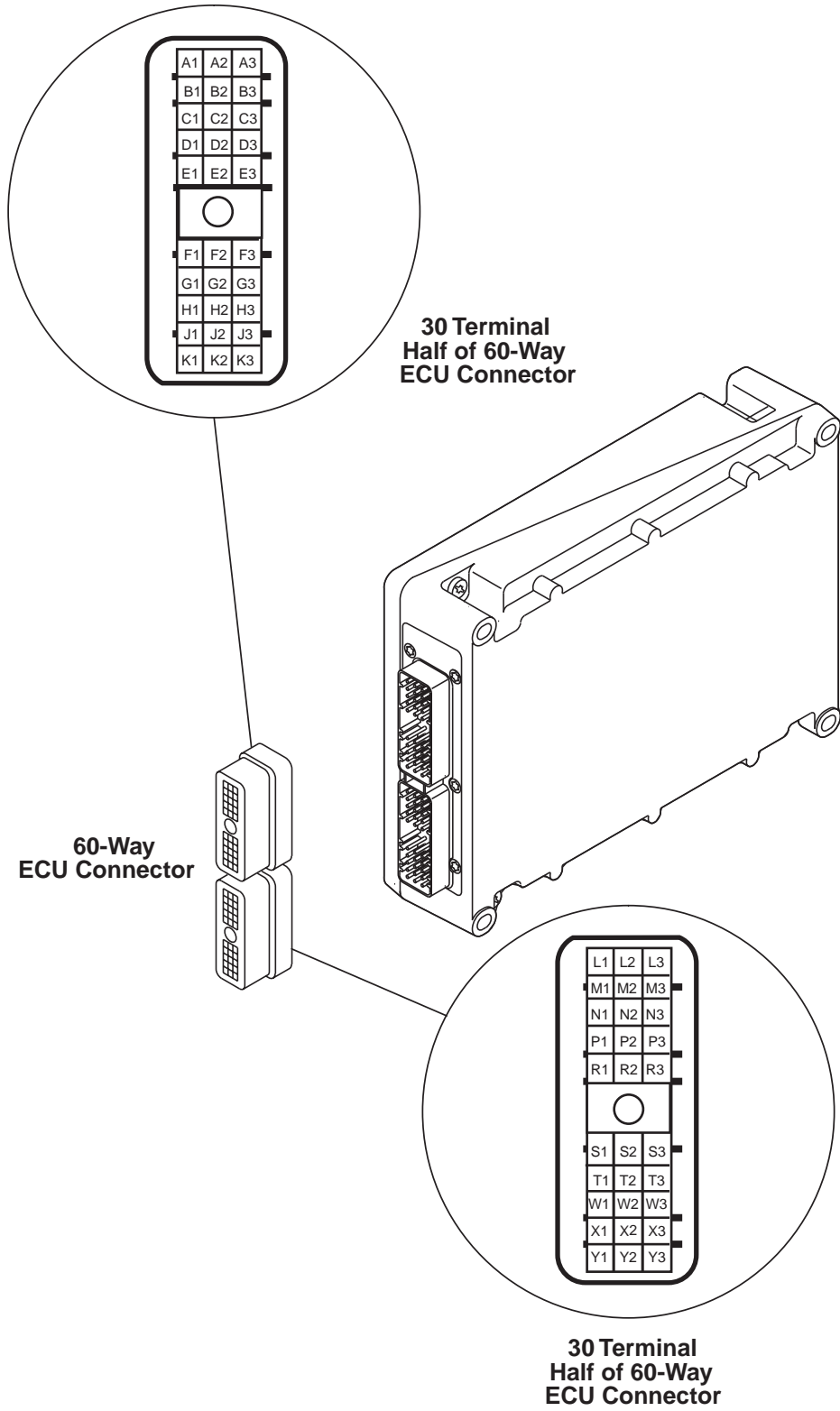

John Deere Level 9 ECU

RG11390 -19-17NOV00

Continued on next page

RG41221,0000023 -19-09OCT00-1/2

# Boom Maintenance, General

## Assembly Instructions

**IMPORTANT:** When removing joint pins or other load-bearing structures bear in mind the following:

- The lifting capacity of the loader or pulley must be adequate.
- The hoisting equipment must be reliable and in good working order.
- The booms must be properly supported in every direction

EL62757,00001C7 -19-22APR02-1/1

## Bleeding the Hydraulic System

If the hydraulic system has been serviced or repaired, air must be eliminated from the system before the machine is put to use again (see Section 7-1)

If not eliminated from the system the presence of air will result in the following problems:

- Sudden, unintended movements
- Damage to gaskets. When compressed, air heats up quickly and burns the packing material.

EL62757,00001C8 -19-22APR02-1/1

# Boom, Maintenance as required

## Adjusting the rotator link brakes

The bolted joint of the link brake pads is tightened through screw **a** while securely holding flanged nut **b**. The maximum tightening torque of the bolted joint is 30 Nm. As soon as the adjustment has been made the bolt joint is secured with locknut **c**.

When the bolted joint is opened for the replacement or check of the brake pads, tension washers **d** must not be removed before loosening the bolted joint.

**IMPORTANT:** For safety reasons the tension washers must be in place before the bolted joint is tightened.

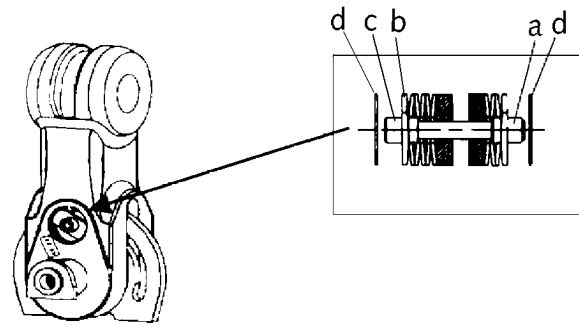

- a—Screw
- b—Flanged nut
- c—Lock nut
- d—Washer

T152582 -UN-11MAR02

EL62757,00001BB -19-21APR02-1/1

### Maintenance and Inspections: Check the refrigerant level.

1. The engine must be running at 1500 RPM.
2. Switch on the air conditioner.
3. Turn the fan speed and thermostat to the maximum position.

When the compressor is running no bubbles should be seen in the sightglass (1), and the refrigerant should not appear 'cloudy'. Bubbles and cloudiness indicate that the charge of refrigerant is insufficient. If this is the case, immediately contact the nearest authorized dealer to have the problem remedied.

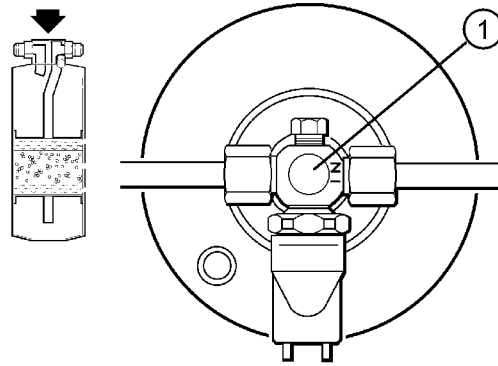

T139550 -UN-06JUN01

1—Inspection sightglass

EL62757,00001DD -19-22APR02-1/5

### A. CLEARLY INSUFFICIENT AMOUNT OF REFRIGERANT

- Continuous flow of bubbles or a flow that appears foamy
- The difference in temperature between the low and high pressure sides is small.
- The pressure of the high-pressure side is unusually low.

STOP THE COMPRESSOR IMMEDIATELY and contact an authorized mechanic to check the system.

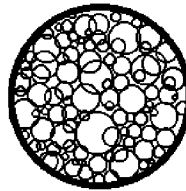

T139551 -UN-15JUN01

Continued on next page

EL62757,00001DD -19-22APR02-2/5

Start heating; press (3).

To reduce heating duration: press (4).

To increase heating duration (to max. 120 min):  
press (5).

b. Permanently

Do not switch heating on.

Press the (4) key and hold it down (approx. 3 s) until  
the display appears and flashes.

Release the key.

Then set the heating duration (10...120 min) using  
the(4) or (5) key. The new heating duration is set when  
the display disappears.

#### 4. **Switching off the heater**

Press (3), automatic cooling phase, about 130  
seconds.

#### 5. **Heating without preselection (ignition of the base machine is on)**

Press (3) .

Heating stays in operation until ignition is switched off.

After ignition is switched off, a residual heating period  
of 15 min remains.

This can be changed (1...120 min) by pressing the (4)  
or (5) key. Switching off the heater: press (3).

#### 6. **Heating operation preselection**

Continued on next page

EL62757,00001FF -19-24APR02-5/9

### Control unit

1. Green light emitting diode, indicating that the system is operative.  
Goes out if the power supply is broken.
2. Yellow light emitting diode, supervising the detector circuit.  
Lights up if the circuit is broken or if the end resistor is removed.
3. Yellow light emitting diode, supervising the circuit to the gas generator in the mechanical / electrical triggering unit.  
Lights up if the circuit is broken or when the gas generator is triggered
4. Yellow light emitting diode.  
Lights up when the system is in the manual mode = Battery master switch is ON.
5. Triggering button for the system.  
Issues a pulsating light when the fire alarm is given and a steady light when the system is triggered electrically.
6. Toggle switch for alarm and error testing.
  - a. **Upper position, testing the alarm.**  
The alarm 5 of the installation shall be activated, push-button (5) flashes and diode (1) and (3) will show a steady light.
  - b. **Middle position: Simulating break of the detector circuit and the detonator loop.**  
Diodes 1, 2 and 3 should light. Diode 4 should also light if the battery master switch is ON. The steady light for the electrically triggered system will also be reset when the toggle switch is moved to the middle position.
  - c. **Lower position, operating mode:**  
Diode 1 should light, and also 4 if the battery master switch is ON.

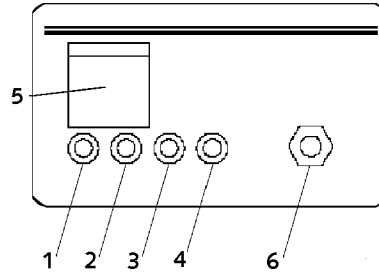

Control unit of the fire extinguisher system

- 1—Green
- 2—Yellow
- 3—Yellow
- 4—Yellow
- 5—Triggering button for the system
- 6—Toggle switch for alarm and error testing

T152354 -UN-06MAR02

### Check every day:

- That diode 1 lights up, and also 4 if the battery master switch is ON, when switch 6 is in the operation mode.

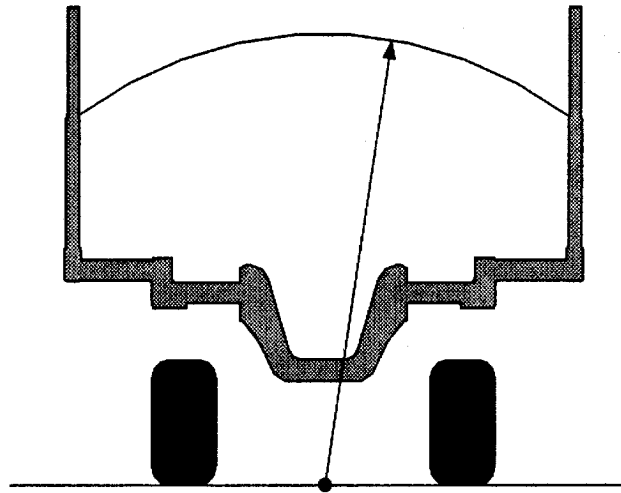

T164532 -UN-24JAN03

*The load should be made low and convex*

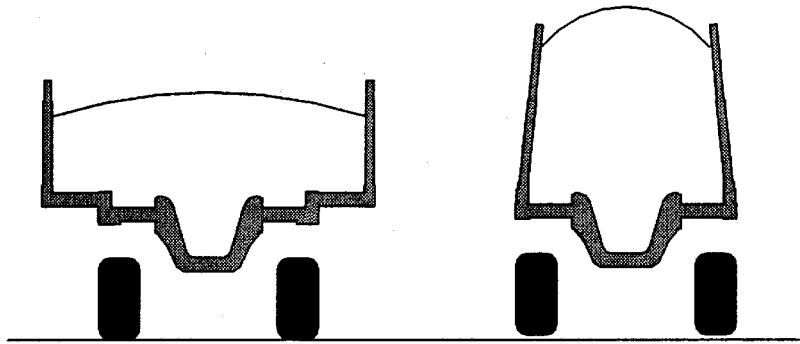

T164533 -UN-24JAN03

*Difference in gravity placement*

### Transportation stability

**IMPORTANT: Take extra precautions the first time.**

The best stability, both static as well as dynamic, is achieved if the load is made low and somewhat convex. Each part of the load will then be as close as possible to a imaginary point on the ground.

If you are used to a wide and low load and then convert the machine to load high and narrow, the difference in gravity placement will be greater than expected.

Continued on next page

EL62757,000042A -18-23JUN03-3/4

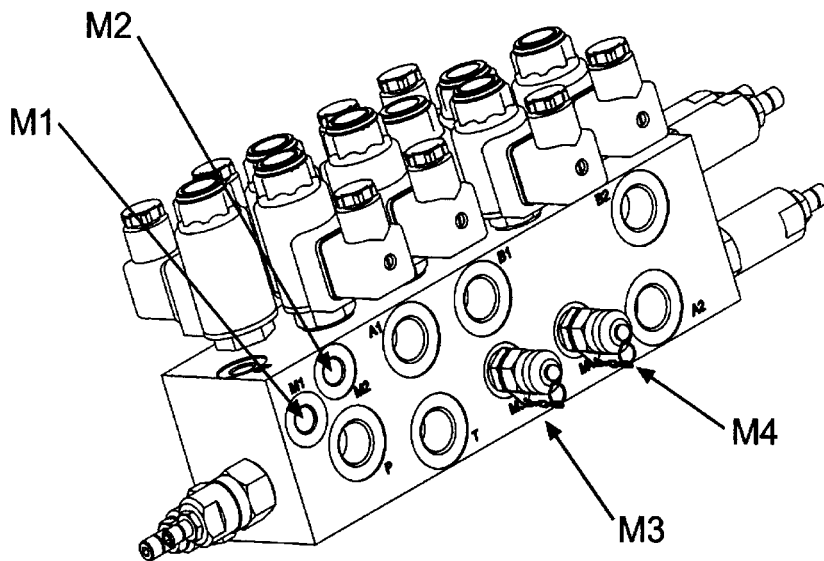

T164542 -UN-24JAN03

Main valve, hydraulic test points

**Hydraulic test points**

Test points	Corresponding position in diagram F622627	Test point Function	Rec. pressure
M1	614	ALS cylinders, right side	(4,5...5,0 MPa) <sup>a</sup>
M2	616	ALS cylinders, left side	(4,5...5,0 MPa) <sup>b</sup>
M3	608	Main pressure	20,0 MPa
M4	609	Telescopic Stake	7,5...8,0 MPa

<sup>a</sup>Ks. Toimenpiteet / Virtauksen ja paineen säätö

<sup>b</sup>See Procedures, Flow and pressure set up

Continued on next page

EL62757,0000430 -18-23JUN03-3/4

4. Push in the Gland by hand and remove the hex hd. cap screw that locks the safety ring.
5. Gently release the spring tension and remove the Gland and the Spring

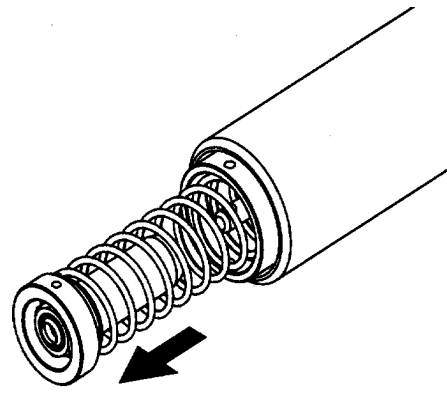

T164557 -UN-24JAN03

EL62757,0000439 -18-23JUN03-3/4

6. Remove the inner tube and the Piston rod

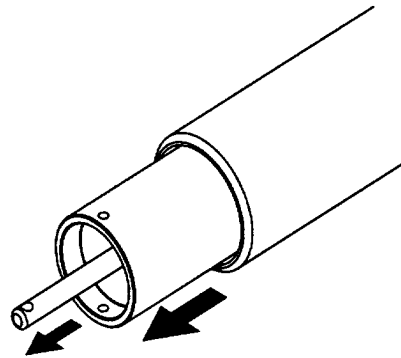

T164558 -UN-24JAN03

EL62757,0000439 -18-23JUN03-4/4

### Principal Hydraulic Diagram

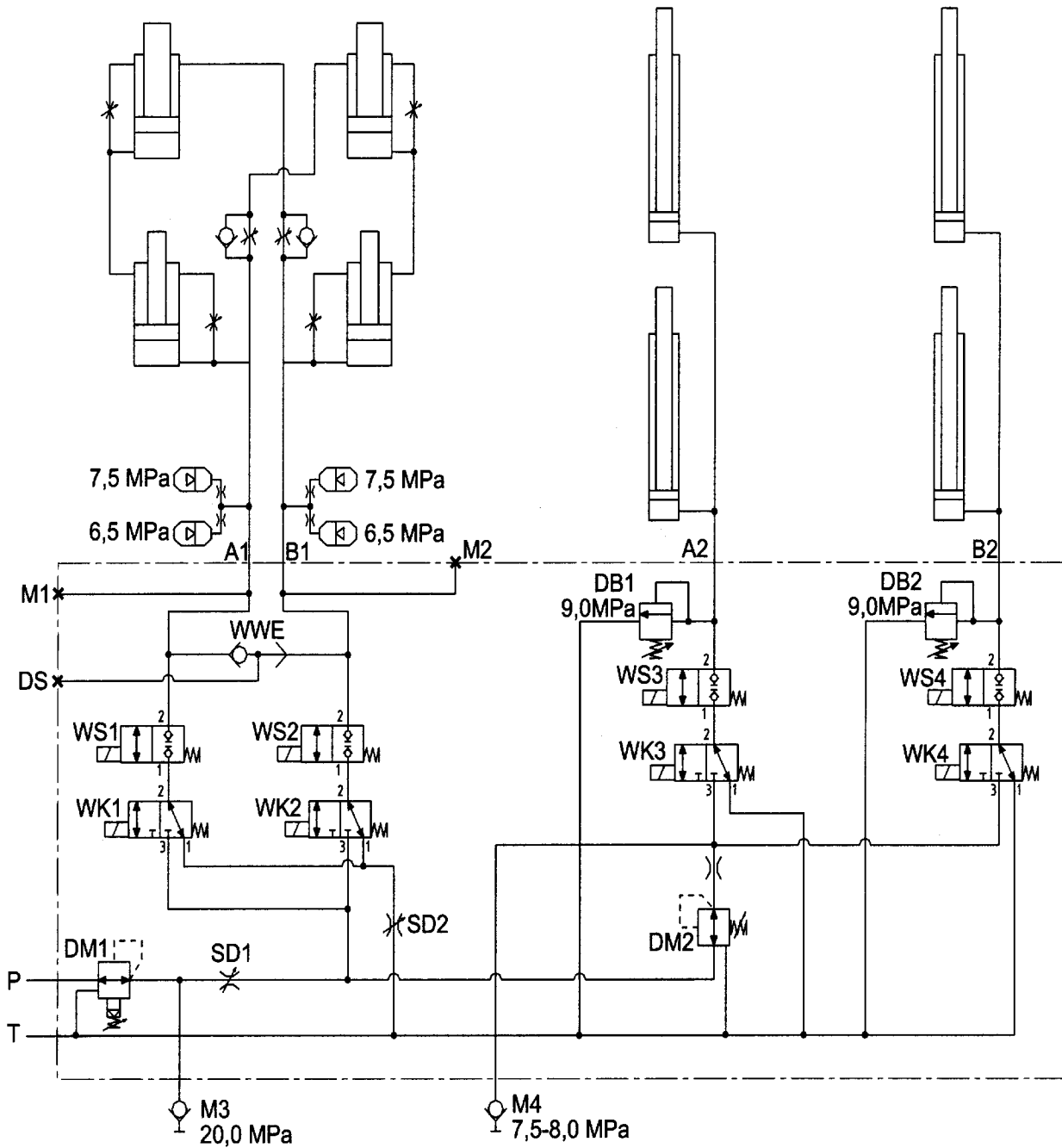

Hydraulic Diagram, ALS

T184545 -UN-24JAN03

EL62757,0000431 -18-23JUN03-1/1

**Display**

Starting Site

1

**STORAGE**  
(Road side)

*Boom must be  
Switched ON!*

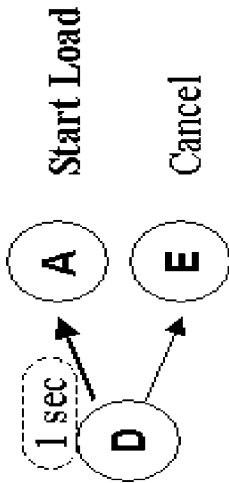

2

**Back in  
STORAGE**  
(Road side)

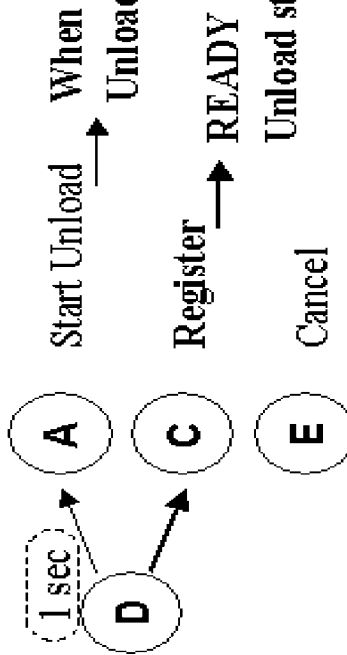

Unload storage

Start again from point 1

1

Zeroing scale

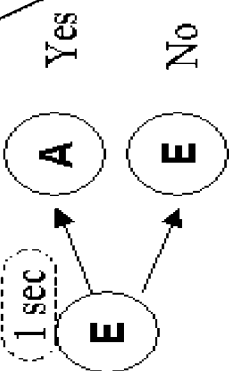

Zeroing the scale, it shows 10 kg without load in grapple. Needed to do ~3-4 times a day. Perform only when in Loading Mode!

**NOTE!** Grapple must be empty & closed before zeroing!

Machine with TMC Display

EL62757.00004BF -19-31OCT03-3/3

T196019 -UN-31OCT03

## Troubleshooting

Symptom	Problem	Solution
<b>Starter will not crank</b>	Loose or corroded connections.	Clean and tighten loose connections.
	Low battery output voltage.	See your Timberjack dealer.
	Faulty start circuit relay.	See your Timberjack dealer.
<b>Starter cranks slowly</b>	Low battery output.	See your Timberjack dealer.
	Crankcase oil too heavy.	Use proper viscosity oil.
	Loose or corroded connections.	Clean and tighten loose connections.

RG, RG34710, 5608 -19-20MAY96-6/6

## Diagnose Drive Lines

Symptom	Problem	Solution
<b>Driveline emitting a chattering noise</b>	Faulty universal joint	See authorized dealer.
	Faulty carrier bearing	See authorized dealer.
<b>Driveline causing machine vibration</b>	Faulty universal joint	See authorized dealer.
	Loose connector bolts at the coupling yokes	See authorized dealer.
	Damaged drive shaft	See authorized dealer.
	Misaligned universal joint yokes	See authorized dealer.

OUTJ003, 0000679 -19-14MAY01-1/1

Symptom	Problem	Solution
<b>All or any loader functions too slow</b>	Insufficient oil.	Check level in hydraulic tank. Add oil, if necessary.
	Defective valve spool port reliefs at loader control valve.	See authorized dealer.
	Defective main relief valve at Loader Control Valve.	See authorized dealer.
	Improper work pump output .	See authorized dealer.
	Defective or worn work pump.	See authorized dealer.
	Engine does not maintain correct RAM	Adjust engine speed control throttle.
<b>Grapple does not hold</b>	Defective control spool in loader control valve.	Service valve. See authorized dealer.
	Defective cylinder seals.	Service cylinder. See authorized dealer.
	Cylinder piston sticking in barrel or loose on rod.	Service cylinder. See authorized dealer.
<b>Loader slews on its own</b>	Defective control spool in loader control valve.	Service valve. See authorized dealer.
<b>Excessive heating</b>	Insufficient oil.	Check level in hydraulic tank. Add oil, if necessary.
	Improper work pump output. Excessive oil flow.	See authorized dealer.
	Defective or worn work pump.	See authorized dealer.
	Blocked hoses or filter.	See authorized dealer.
	Defective valve spool port reliefs at loader control valve.	Service valve. See authorized dealer.
	Defective main relief valve at Loader Control Valve.	Service valve. See authorized dealer.

Continued on next page

OUTJ003,0000680 -19-14MAY01-2/4

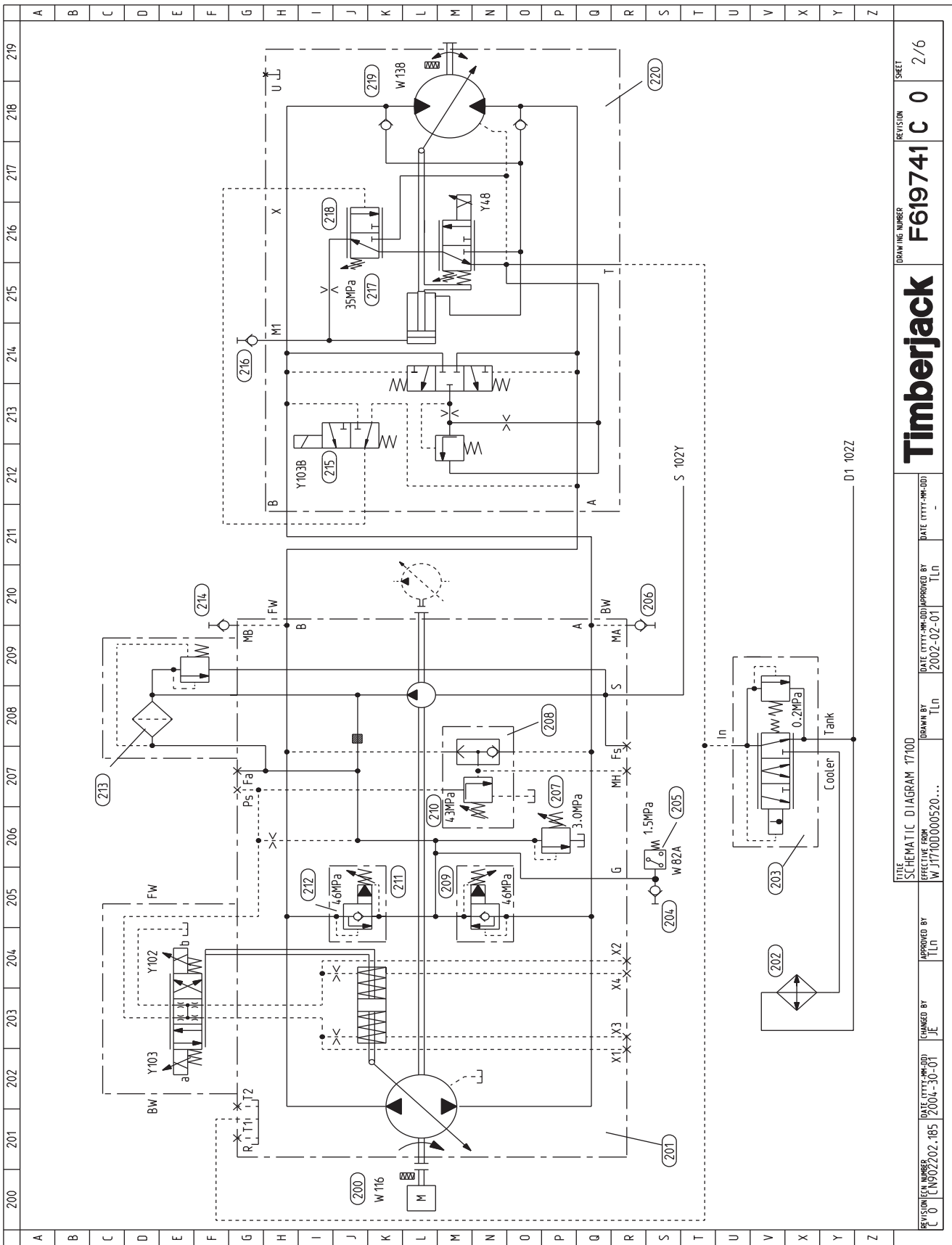

REVISION NUMBER	0	DATE (YYYY-MM-DD)	2004-30-01	CHANGED BY	JE	APPROVED BY	Tln
EFFECTIVE FROM	WJ7700000520...	DATE (YYYY-MM-DD)	2002-02-01	DRAWN BY	Tln	DATE (YYYY-MM-DD)	2002-02-01
APPROVED BY	Tln	DATE (YYYY-MM-DD)	2002-02-01	DRAWN BY	Tln	DATE (YYYY-MM-DD)	2002-02-01
TITLE	SCHEMATIC DIAGRAM 17100						
DRAWING NUMBER	F619741 C 0						
REVISION	0						
SHEET	2/6						

**Timberjack**

### Wiring Diagram Explanations

1. Seek column	4. Reference, seek column 608 E	7. Connector hose X16 terminal 9	10. Single line	13. Operation symbol
2. Double lines, conductor on circuit card	5. Earth terminal, connector X3 terminal 3	8. Number of wire 65+	11. Magnet valve Y65	
3. Relay K7	6. Fuse 25, 10A	9. S9 in the box, not mounted in all machines	12. Machine frame	

Codes for electric wire colors:							
BE = blue	BL =black	BR = brown	GN = green	GR = gray	OR = orange	RD = red	YL = yellow

EL62757,00001EF -19-24APR02-2/3

### Ignition key positions

In the illustration is shown which connectors are in use in different positions of the ignition switch.

- A—Connectors
- B—Ignition key positions

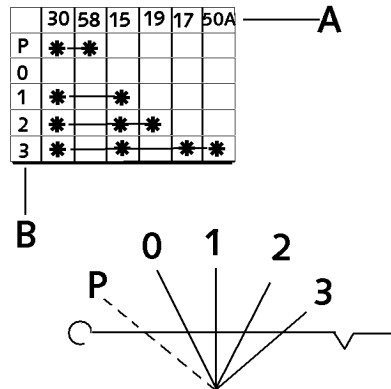

T159290 -UN-15OCT02

EL62757,00001EF -19-24APR02-3/3





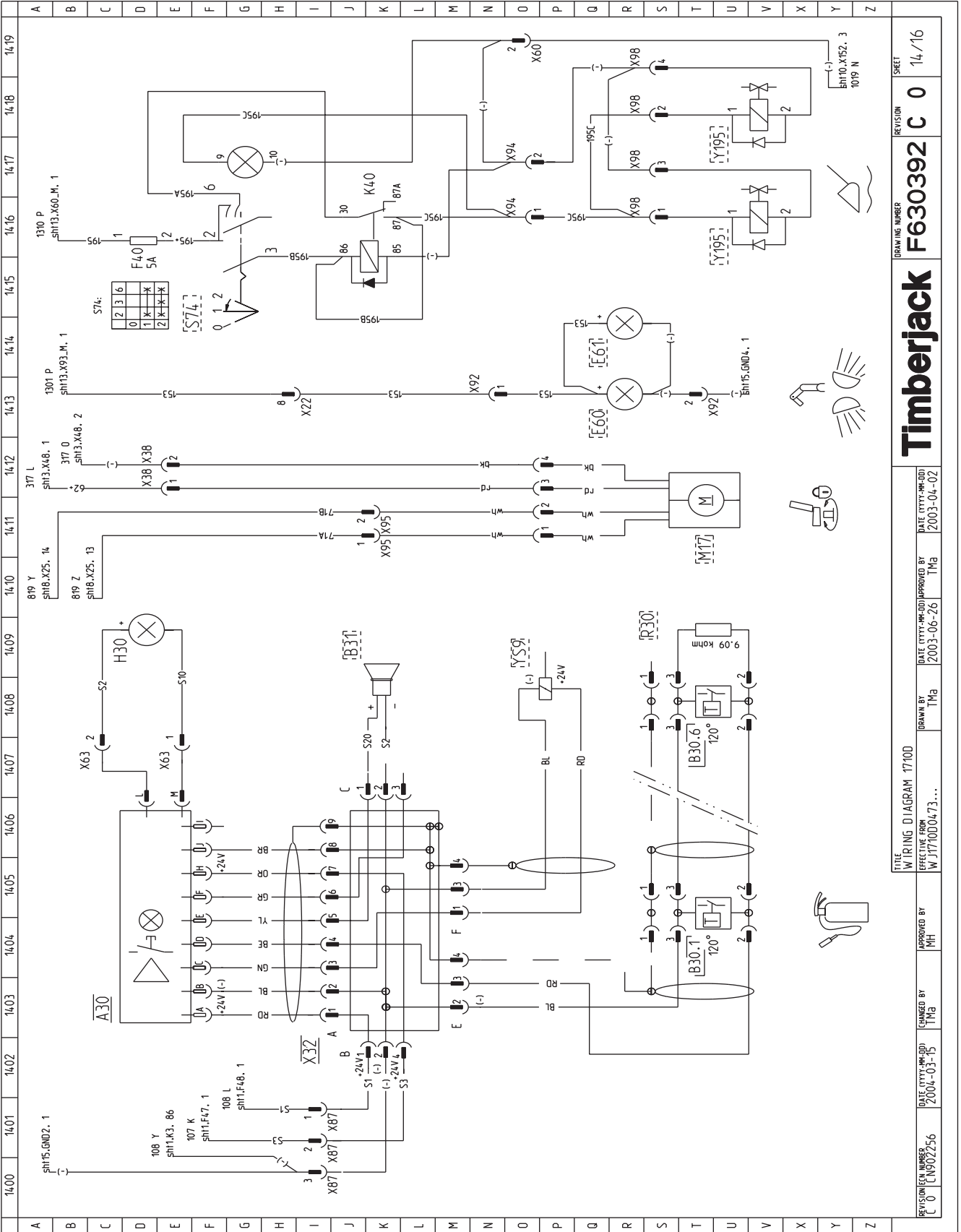

TITLE		DRAWING NUMBER		REVISION		SHEET	
WIRING DIAGRAM 17100		F630392 C 0		14/16			
DATE (YYYY-MM-DD)	APPROVED BY	DATE (YYYY-MM-DD)	APPROVED BY	DATE (YYYY-MM-DD)	APPROVED BY	DATE (YYYY-MM-DD)	APPROVED BY
2004-03-15	TMb	2003-06-26	TMb	2003-04-02	TMb	2003-04-02	TMb
CHANGED BY	APPROVED BY	CHANGED BY	APPROVED BY	CHANGED BY	APPROVED BY	CHANGED BY	APPROVED BY
TMb	MH	TMb	MH	TMb	MH	TMb	MH

CLICK HERE TO **DOWNLOAD** THE COMPLETE MANUAL

- Thank you very much for reading the preview of the manual.
- You can download the complete manual from: [www.heydownloads.com](http://www.heydownloads.com) by clicking the link below



- Please note: If there is no response to CLICKING the link, please download this PDF first and then click on it.

CLICK HERE TO **DOWNLOAD** THE COMPLETE MANUAL