

CONTENTS

Foreword	0-1	6. Traveling of the machine	4-14			
Before servicing this machine	0-2	7. Efficient working method	4-17			
EC regulation approved	0-3	8. Operation in the special work sites	4-21			
Table to enter S/No and distribution	0-4	9. Normal operation of excavator	4-23			
Safety labels	0-5	10. Attachment lowering	4-24			
Machine data plate	0-15	11. Storage	4-25			
Guide(Direction, S/No, Symbol)	0-16	12. RCV lever operating pattern	4-27			
		13. Switching hydraulic attachment circuit	4-28			
SAFETY HINTS						
1. Before operating the machine	1-1	TRANSPOTATION				
2. During operating the machine	1-6	1. Preparation for transportation	5-1			
3. During maintenance	1-13	2. Dimension and weight	5-2			
4. Parking	1-16	3. Loading the machine	5-4			
		4. Fixing the machine	5-6			
SPECIFICATIONS				5. Loading and unloading by crane	5-7	
1. Major components	2-1	MAINTENANCE				
2. Specifications	2-2	1. Instruction	6-1			
3. Working range	2-3	2. Tightening torque	6-6			
4. Weight	2-4	3. Fuel, coolant and lubricants	6-9			
5. Lifting capacities	2-5	4. Maintenance check list	6-11			
6. Bucket selection guide	2-8	5. Maintenance chart	6-16			
7. Undercarriage	2-10	6. Service instruction	6-18			
8. Specification for major components	2-12	7. Electrical system	6-42			
9. Recommended oils	2-16	8. Air conditioner and heater	6-45			
CONTROL DEVICES				TROUBLESHOOTING GUIDE		
1. Cab devices	3-1	1. Engine	7-1			
2. Cluster	3-2	2. Electrical system	7-2			
3. Switches	3-9	3. Others	7-3			
4. Levers and pedals	3-14	HYDRAULIC BREAKER				
5. Air conditioner and heater	3-16	1. Selecting hydraulic breaker	8-1			
6. Others	3-23	2. Circuit configuration	8-2			
OPERATION				3. Maintenance	8-3	
1. Suggestion for new machine	4-1	4. Precautions while operating the breaker	8-4			
2. Check before starting the engine	4-2	5. Quick clamp	8-6			
3. Starting and stop the engine	4-3	INDEX				9-1
4. Mode selection system	4-6					
5. Operation of the working device	4-13					

CLICK HERE TO **DOWNLOAD** THE COMPLETE MANUAL

- Thank you very much for reading the preview of the manual.
- You can download the complete manual from: www.heydownloads.com by clicking the link below



- Please note: If there is no response to CLICKING the link, please download this PDF first and then click on it.

CLICK HERE TO **DOWNLOAD** THE COMPLETE MANUAL

14) NO STEP-ENGINE HOOD(Item 18)

This warning label is positioned on the engine hood.

△ Do not step on the engine hood.

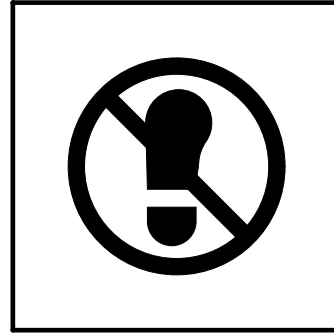

21070FW16

15) TRANSPORTING(Item 19)

This warning label is positioned right side of upper frame.

▲ Study the operator's manual before transporting the machine, if provided and tie down arm and track to the carrier with lashing wire.

※ See page 5-6 for details.

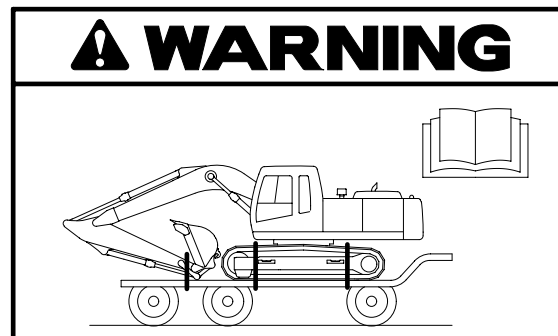

14070FW17

16) CONTROL IDEOGRAM(Item 21)

This warning label is positioned in right window of the cab.

▲ Check the machine control pattern for conformance to pattern on this label. If not, change label to match pattern before operating machine.

▲ Failure to do so could result in injury or death.

※ See page 4-14 for details.

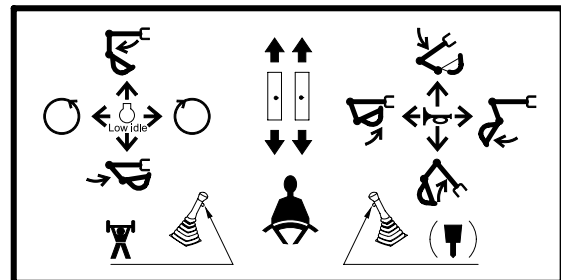

36070FW19

17) CONTROL IDEOGRAM-LH(Item 22)

This warning label is positioned on the LH console box.

▲ Check the machine control pattern for conformance to pattern on this label. If not, change label to match pattern before operating machine.

▲ Failure to do so could result in injury or death.

※ See page 4-14 for details.

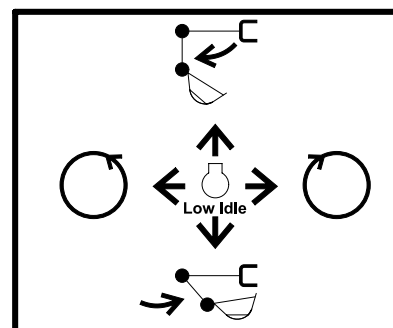

36070FW20

ROTATING BEACON

When you operate a machine on a road or beside a road, a rotating beacon is required to avoid any traffic accident.

Please contact your Hyundai distributor to install it.

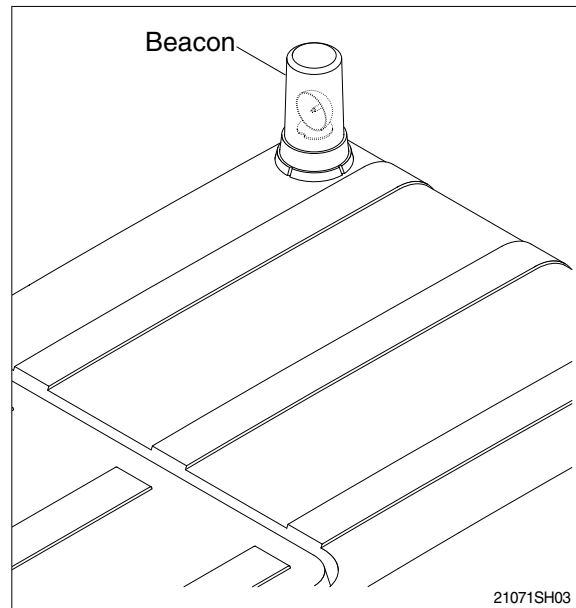

PRECAUTIONS FOR ATTACHMENTS

When installing and using an optional attachment, read the instruction manual for the attachment and the information related to attachments in this manual.

Do not use attachments that are not authorized by Hyundai or your Hyundai distributor. Use of unauthorized attachments could create a safety problem and adversely affect the proper operation and useful life of the machine.

Any injuries, accidents, product failures resulting from the use of unauthorized attachments are not the responsibility of Hyundai.

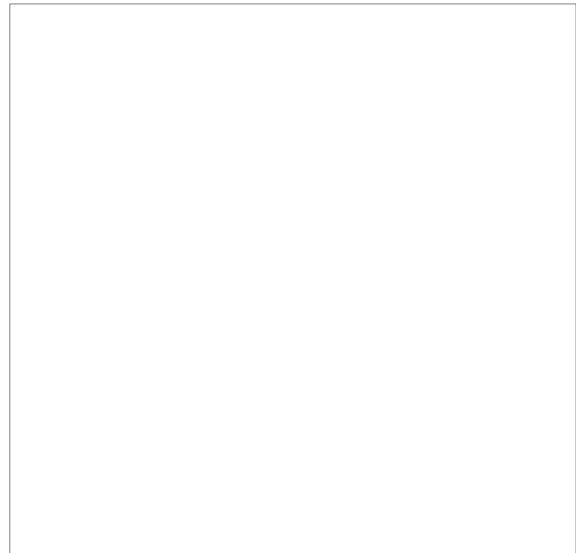

SAFETY RULES

Only trained and authorized personnel can operate and maintain the machine.

Follow all safety rules, precautions and instructions when operating or performing maintenance on the machine.

When working with another operator or a person on worksite traffic duty, be sure all personnel understand all hand signals that are to be used.

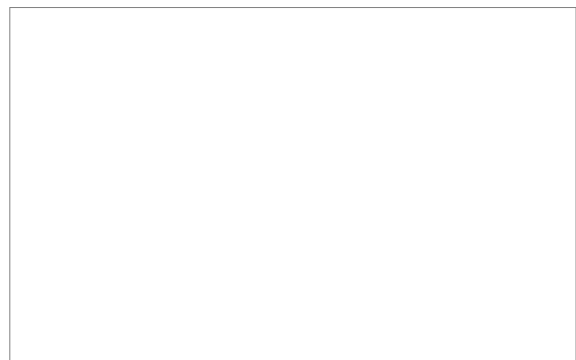

There is the danger of fire in fuel and oil.
Store in cool and dry area, away from any open flames.

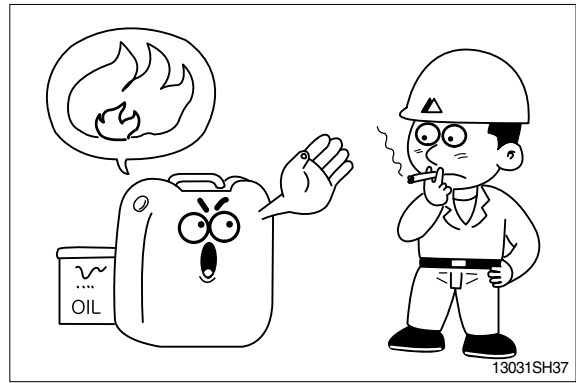

Do not touch exhaust pipe, or may cause severe burn.

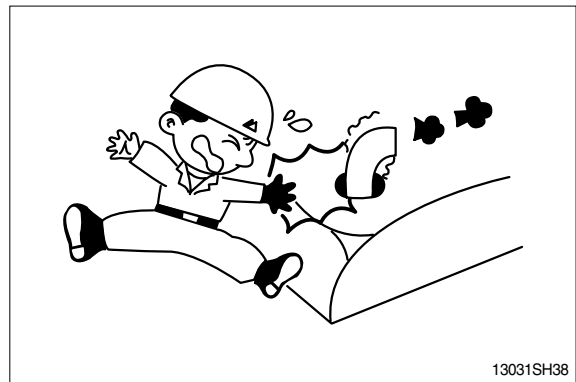







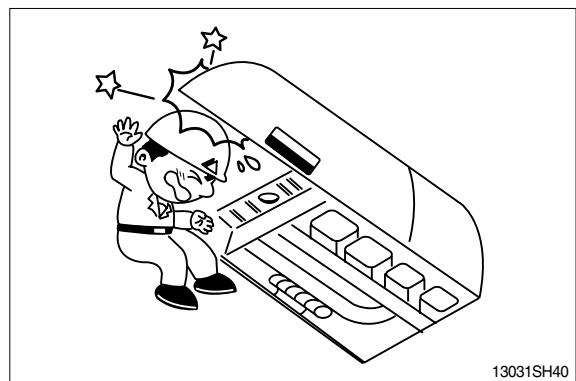



Do not open the engine hood and covers while the engine is running.

















Be careful of not hitting the edges when you service engine.



2) 6.5m(21' 4") boom, 2.50m(8' 2") arm equipped with 1.62m³(SAE heaped) bucket and 600mm (24") triple grouser shoe with 6500kg(14,330lb) counterweight.

Load point height		Load radius								At max. reach				
		3.0m(10ft)		4.5m(15ft)		6.0m(20ft)		7.5m(25ft)		Capacity		Reach		
												m(ft)		
9.0m (30ft)	kg lb											*6900 *15210	*6900 *15210	7.22 (23.7)
7.5m (25ft)	kg lb											*6870 *15150	5190 11440	8.49 (27.9)
6.0m (20ft)	kg lb					*8050 *17750	*8050 *17750	*7580 *16710	6370 14040			*6970 *15370	4240 9350	9.29 (30.5)
4.5m (15ft)	kg lb			*11980 *26410	*11980 *26410	*9400 *20720	8990 19820	*8180 *18030	6110 13470			6550 14440	3720 8200	9.77 (32.1)
3.0m (10ft)	kg lb			*15410 *33970	12960 28570	*11030 *24320	8330 18360	*9020 *19890	5790 12760			6210 13690	3470 7650	9.97 (32.7)
1.5m (5ft)	kg lb			*17780 *39200	12000 26460	*12460 *27470	7780 17150	9750 21500	5490 12100			6180 13620	3430 7560	9.91 (32.5)
Ground Line	kg lb			*18570 *40940	11650 25680	*13320 *29370	7450 16420	9520 20990	5280 11640			6490 14310	3610 7960	9.59 (31.5)
-1.5m (-5ft)	kg lb	*17800 *39240	*17800 *39240	*18280 *40300	11630 25640	*13480 *29720	7340 16180	9440 20810	5210 11490			7260 16010	4070 8970	8.97 (29.4)
-3.0m (-10ft)	kg lb	*23550 *51920	*23550 *51920	*17040 *37570	11830 26080	*12770 *28150	7430 16380					*8130 *17920	5070 11180	7.97 (26.1)
-4.5m (-15ft)	kg lb	*19520 *43030	*19520 *43030	*14370 *31680	12280 27070							*7460 *16450	7460 16450	6.39 (21.0)

3) 6.5m(21' 4") boom, 3.9m(12' 10") arm equipped with 1.62m³(SAE heaped) bucket and 600mm (24") triple grouser shoe with 6500kg(14,330lb) counterweight.

Load point height		Load radius										At max. reach					
		1.5m(5ft)		3.0m(10ft)		4.5m(15ft)		6.0m(20ft)		7.5m(25ft)		9.0m(30ft)		Capacity		Reach	
																m(ft)	
9.0m (30ft)	kg lb														*5290 *11660	5130 11310	8.81 (28.9)
7.5m (25ft)	kg lb														*5420 *11950	4000 8820	9.85 (32.3)
6.0m (20ft)	kg lb								*5890 *12990	*5890 *12990	*3660 *8070	*3660 *8070	*5590 *12320	3360 7410	10.54 (34.6)		
4.5m (15ft)	kg lb								*6660 *14680	6330 13960	*5450 *12020	4440 9790	5380 11860	2980 6570	10.95 (35.9)		
3.0m (10ft)	kg lb			*19900 *43870	*19900 *43870	*12040 *26540	*12040 *26540	*9120 *20110	8690 19160	*7660 *16890	5930 13070	*6860 *15120	4230 9330	5120 11290	2780 6130	11.13 (36.5)	
1.5m (5ft)	kg lb			*12660 *27910	*12660 *27910	*15330 *33800	12590 27760	*10910 *24050	7990 17610	*8710 *19200	5540 12210	7200 15870	4000 8820	5060 11160	2720 6000	11.07 (36.3)	
Ground Line	kg lb			*13680 *30160	*13680 *30160	*17420 *38400	11750 25900	*12310 *27140	7470 16470	9470 20880	5220 11510	6990 15410	3820 8420	5230 11530	2800 6170	10.79 (35.4)	
-1.5m (-5ft)	kg lb	*12590 *27760	*12590 *27760	*16830 *37100	*16830 *37100	*18250 *40230	11390 25110	*13100 *28880	7170 15810	9240 20370	5020 11070	6870 15150	3710 8180	5670 12500	3060 6750	10.26 (33.7)	
-3.0m (-10ft)	kg lb	*16200 *35710	*16200 *35710	*21040 *46390	*21040 *46390	*18030 *39750	11340 25000	*13170 *29030	7080 15610	9170 20220	4960 10930		6560 14460	3600 7940	9.42 (30.9)		
-4.5m (-15ft)	kg lb	*20270 *44690	*20270 *44690	*24240 *53440	*24240 *53440	*16700 *36820	11540 25440	*12330 *27180	7180 15830	*9270 *20440	5080 11200		*7640 *16840	4710 10380	8.17 (26.8)		
-6.0m (-20ft)	kg lb			*19460 *42900	*19460 *42900	*13690 *30180	12040 26540										

3) GEAR PUMP

Item	Specification
Type	Fixed displacement gear pump single stage
Capacity	15cc/rev
Maximum pressure	35kgf/cm ² (500psi)
Rated oil flow	27 l /min(7.1U.S. gpm/5.9U.K. gpm)

4) MAIN CONTROL VALVE

Item	Specification
Type	7 spools
Operating method	Hydraulic pilot system
Main relief valve pressure	330kgf/cm ² (4690psi)[360kgf/cm ² (5120psi)]
Overload relief valve pressure	390kgf/cm ² (5550psi)

[]: Power boost

5) SWING MOTOR

Item	Specification
Type	Axial piston motor
Capacity	250cc/rev
Relief pressure	260kgf/cm ² (3700psi)
Braking system	Automatic, spring applied hydraulic released
Braking torque	107kgf · m(773lbf · ft)
Brake release pressure	30~50kgf/cm ² (427~711psi)
Reduction gear type	2 - stage planetary
Swing speed	9.0rpm

6) TRAVEL MOTOR

Item	Specification
Type	Variable displacement axial piston motor
Relief pressure	360kgf/cm ² (5120psi)
Capacity(max / min)	185.2/114.2cc/rev
Reduction gear type	3-stage planetary
Braking system	Automatic, spring applied hydraulic released
Brake release pressure	8.5kgf/cm ² (121psi)
Braking torque	44.4kgf · m(321lbf · ft)

2) SWITCH PANEL

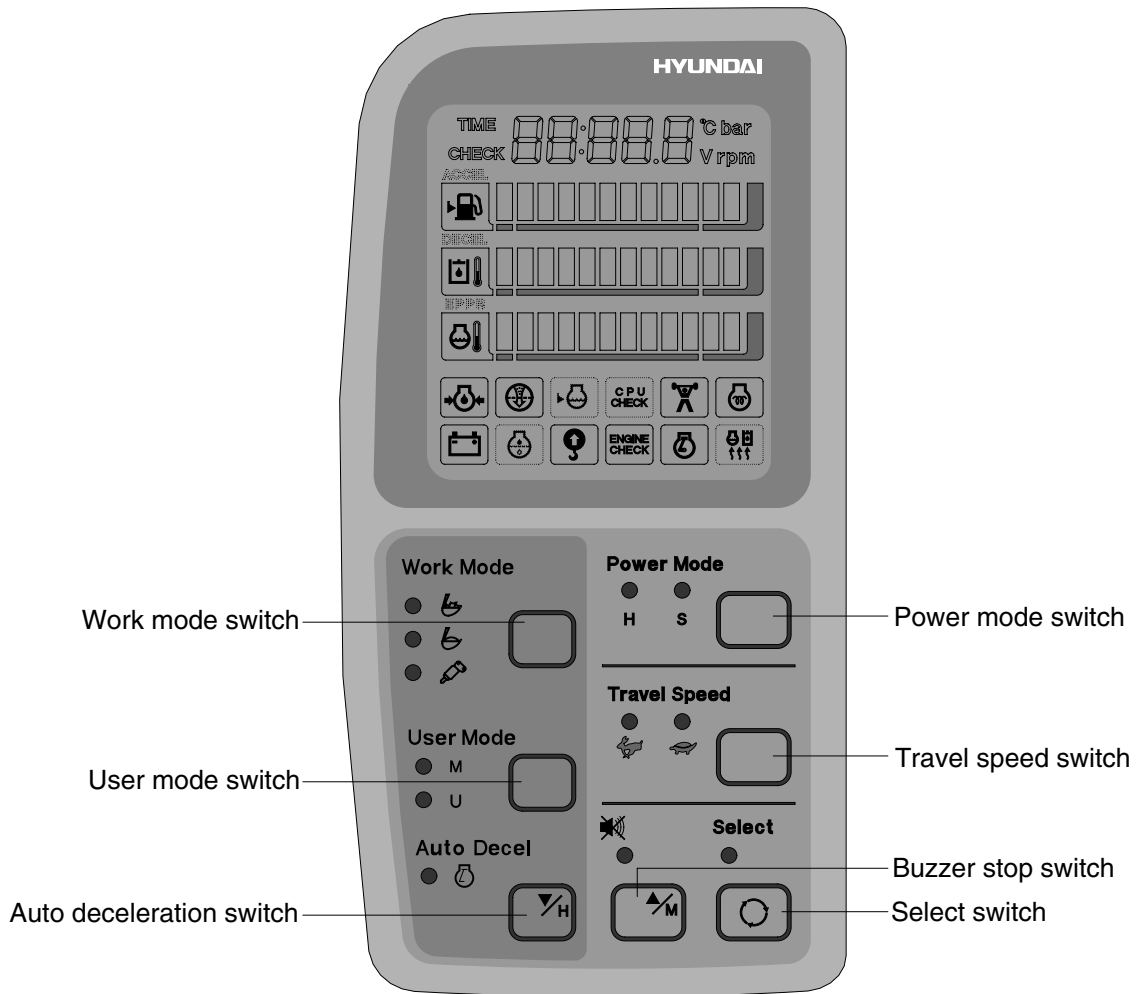

3607A3CD19

(1) Work mode switch

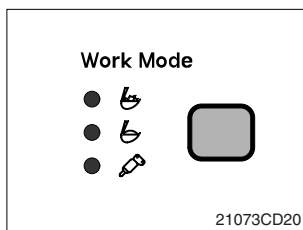

① This switch is to select the machine operation mode, which shifts from general operation mode to heavy operation mode and breaker mode in a row by pressing the switch.

- : Heavy duty work mode
- : General work mode
- : Breaker operation mode

※ Refer to the page 4-7 for details.

(2) User mode switch

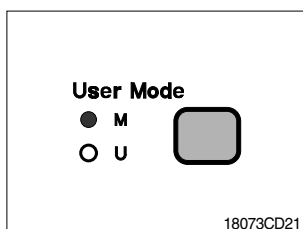

① This switch is to select the maximum power or user mode.

- M : Maximum power
- U : Memorizing operators preferable power setting

※ Refer to the page 4-7 for details.

(6) Engine check warning lamp

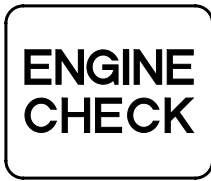

29073CD10

- ① This lamp blinks and the buzzer sounds when the communication between MCU controller and ECU on the engine is abnormal, or if any fault code received from ECU.
- ② Check the communication line between them.
If the communication line is OK, then check the fault code on the cluster

(7) Power max pilot lamp



21073CD11

- ① The lamp will be ON when pushing power max switch on the LH RCV lever.

(8) Decel pilot lamp

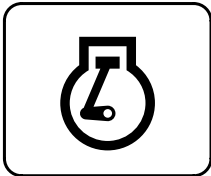

21073CD17

- ① Operating auto decel or one touch decel makes the lamp ON.
- ② The lamp will be ON when pushing one touch decel switch on the LH RCV lever.

(9) Warming up pilot lamp

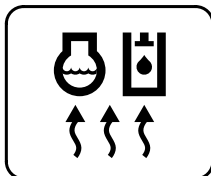

21073CD18

- ① This lamp is turned ON when the coolant temperature is below 30°C (86 °F).
- ② The automatic warming up is cancelled when the engine coolant temperature is above 30 °C, or when 10 minutes have passed since starting.

(10) Preheat pilot lamp



21073CD12

- ① Turning the start key switch ON position starts preheating in cold weather.
- ② Start the engine as this lamp is OFF.

5. AIR CONDITIONER AND HEATER

Air conditioner and heater are equipped for pleasant operation against outside temperature and defrost on window glass.

- Location of air flow ducts

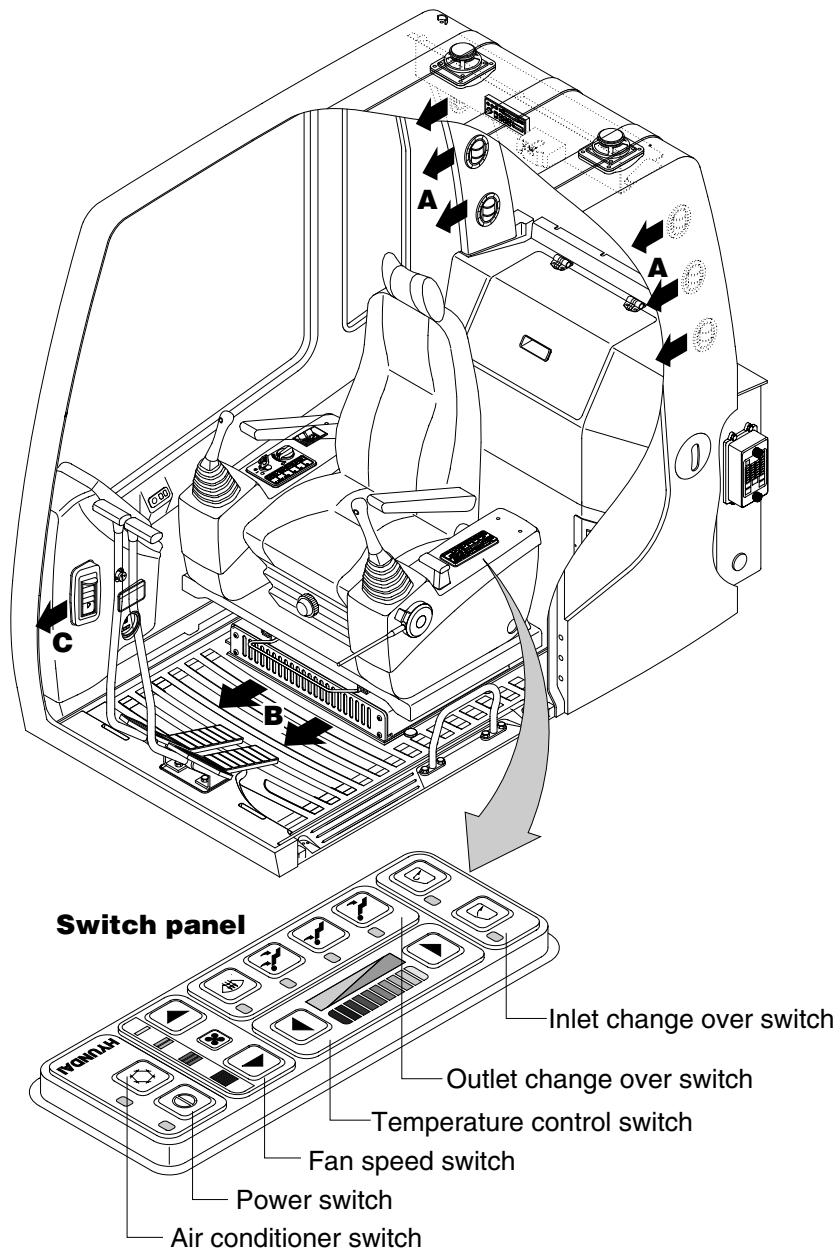

1407A3CD12

6) EMERGENCY ENGINE STARTING CONNECTOR

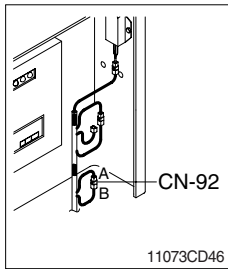

- (1) If the MCU controller is removed, the engine does not start.
 - (2) Before starting the engine, connect the connector CN-92 A with B.
- ※ **Do not connect these connectors when the MCU is not removed.**

7) EMERGENCY ENGINE SPEED CONTROL

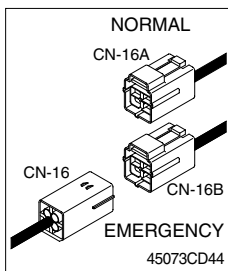

- (1) When the CAN communication between the ECM and the MCU controller is abnormal due to malfunction of the MCU controller, change CN-16 connection from CN-16A to CN-16B and then control the engine speed by rotating accel dial switch.

8) PROLIX RESISTOR

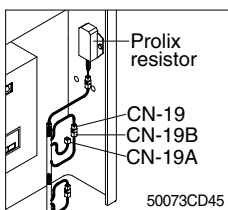

- (1) This resistor is used to continuous working in case of malfunction of the MCU controller.
 - Normal : CN-19 connect with connector CN-19A
 - Emergency : CN-19 connect with connector CN-19B
- ※ **Never connect connector CN-19 with connector CN-19B when MCU controller is in normal operation.**

9) SERVICE METER

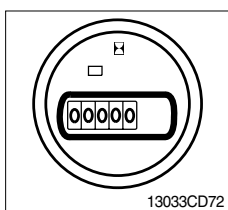

- (1) This meter shows the total operation hours of the machine.
- (2) Always ensure the operating condition of the meter during the machine operation. Inspect and service the machine based on hours as indicated in chapter 6, **maintenance**.

10) RS232 SERIAL CONNECTOR

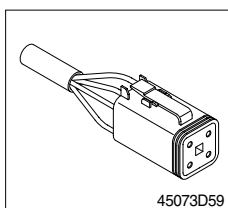

- (1) MCU controller communicates the machine data with Lap top computer through RS232 connector.

CLICK HERE TO **DOWNLOAD** THE COMPLETE MANUAL

- Thank you very much for reading the preview of the manual.
- You can download the complete manual from: www.heydownloads.com by clicking the link below



- Please note: If there is no response to CLICKING the link, please download this PDF first and then click on it.

CLICK HERE TO **DOWNLOAD** THE COMPLETE MANUAL

(3) Volume button(down)

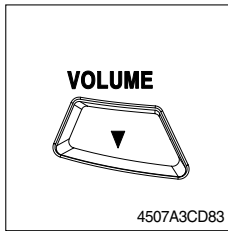

- Short press : Volume down one step
- Long press : Volume down continuous.

(4) Source & mute button



- Short press : Change source(Radio/CD)
- Long press : To mute or cancel mute.

(5) Next button

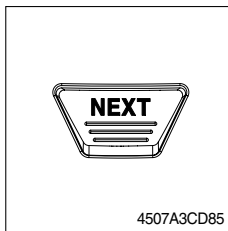

- ① Tuner mode
 - Short press : Preset up
 - Long press : Band up
- ② Cassette mode
 - Short press : Reverse(before the end of the tape)
 - Long press : No function
- ③ CD mode
 - Short press : Track 1
 - Long press : Scan track

(6) Search button(up)

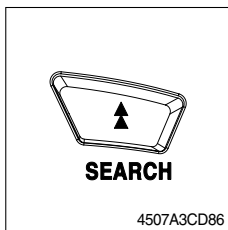

- ① Tuner mode
 - Short press : Search up one step
 - Long press : Search up continuous
- ② Cassette & CD mode
 - Short press : Next track
 - Long press : Fast forward

(7) Search button(down)

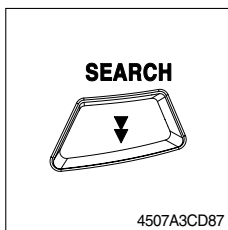

- ① Tuner mode
 - Short press : Search down one step
 - Long press : Search down continuous
- ② Cassette & CD mode
 - Short press : Previous track
 - Long press : Fast rewind

4. MODE SELECTION SYSTEM (up to #0077)

1) STRUCTURE OF CAPO SYSTEM

CAPO, Computer Aided Power Optimization system, is the name of mode selection system developed by Hyundai.

(1) Work mode

3 work modes can be selected for the optimal work speed of the machine operation.

① Heavy duty work mode

The boom priority solenoid is activated to make the boom operation speed faster.

② General work mode

When key switch is turned ON, this mode is selected automatically and swing operation speed is faster than heavy duty work mode.

③ Breaker operation mode

It sets the pump flow to the optimal operation of breaker by activating the max flow cut-off solenoid.

(2) Power mode

Power mode designed for various work loads maintains high performance and reduces fuel consumption.

- H mode : High power
- S mode : Standard power

(3) User mode

- M : Maximum power
- U : You can change the engine and pump power and memorize it for your preference

How to modulate the memory set

- ① Each memory mode has a initial set which are mid-range of max engine speed, auto decel rpm, and EPPR valve input current. When you select U, cluster LCD displays.

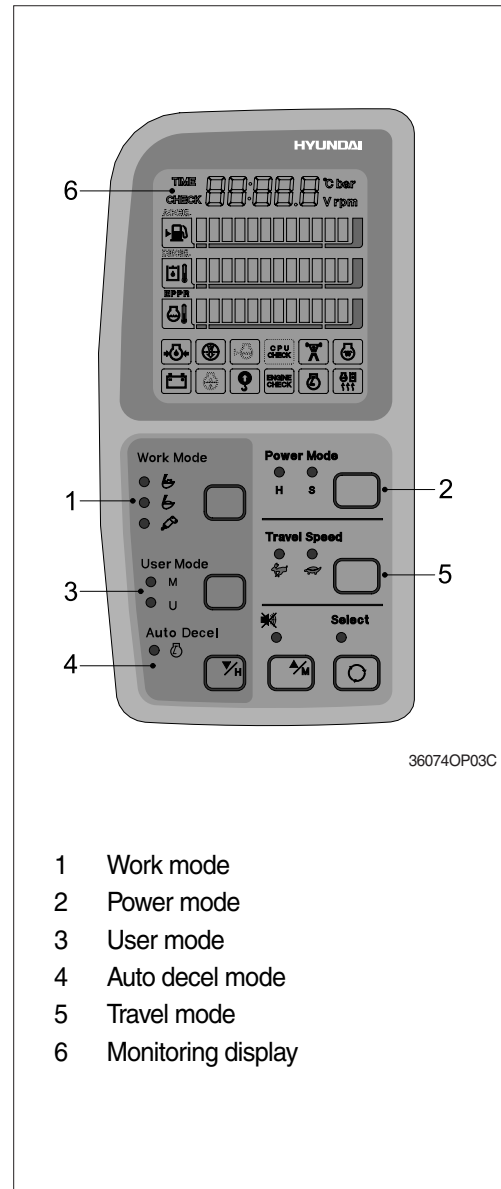

- 1 Work mode
- 2 Power mode
- 3 User mode
- 4 Auto decel mode
- 5 Travel mode
- 6 Monitoring display

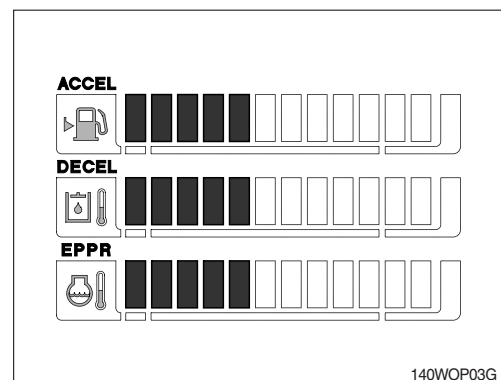

(2) After engine start

- ① When the engine is started, three lamps are ON as below.

Mode		Status
Work mode		ON
Power mode	S	ON
Travel mode	Low(ON
Auto decel mode		ON

- In this condition, tachometer indicates low idle, 850 ± 100 rpm.
- If coolant temperature is below 30°C , after 10 seconds the engine speed increases to 1000 ± 100 rpm automatically to warm up the machine.
- After 2-3 minutes, you can select any mode depending on job requirement.

- ② Self-diagnostic function can be carried out the same as start key is ON.

※ Refer to the page 3-6 for details.

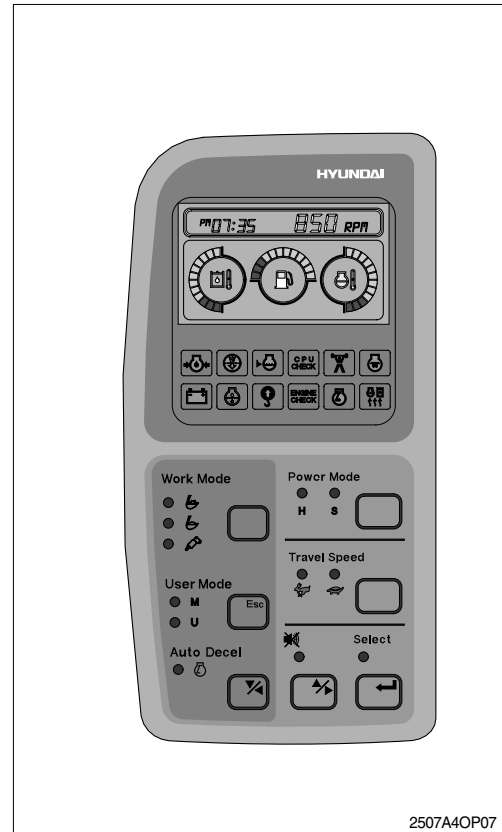

3) SELECTION OF POWER MODE

(1) S mode

When the accel dial is at setting 10 and auto decel mode is cancelled and S mode is selected.

Engine rpm	Effect
1750 ± 50	Same power as non mode type machine.

- ※ When the accel dial is located below 9 the engine speed decreases about 50~100rpm per dial set.

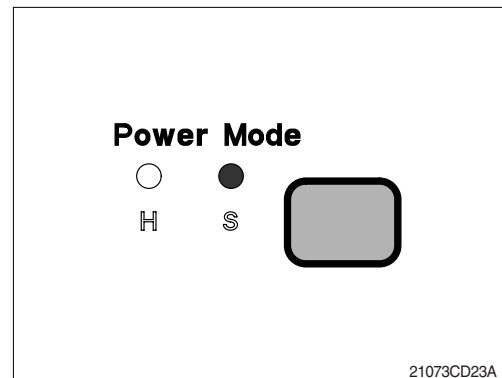

(2) H mode

When the accel dial is at setting 10 and auto decel mode is cancelled and H mode is selected.

Engine rpm	Effect
1850 ± 50	Approximately 110% of power and speed available than non mode type machine or S mode.

- ※ When the accel dial is located below 9 the engine speed decreases about 50~100rpm per dial set.

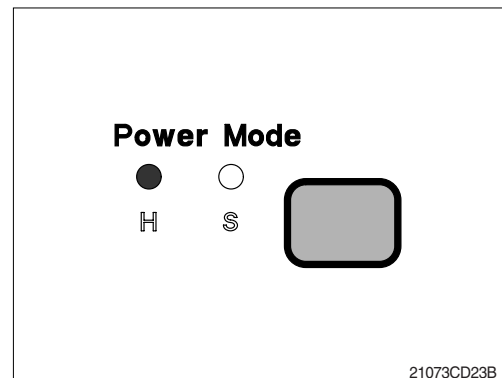

8. OPERATION IN THE SPECIAL WORK SITES

1) OPERATION THE MACHINE IN A COLD WEATHER

- (1) Use proper engine oil and fuel for the weather.
- (2) Fill the required amount of antifreeze in the coolant.
- (3) Refer to the starting engine in cold weather.
Start the engine and extend the warming up operation.
- (4) Be sure to open the heater cock when using the heater.
- (5) Always keep the battery completely charged.
※ **Discharged battery will freeze more easily than fully charged.**
- (6) Clean the machine and park on the wood plates.

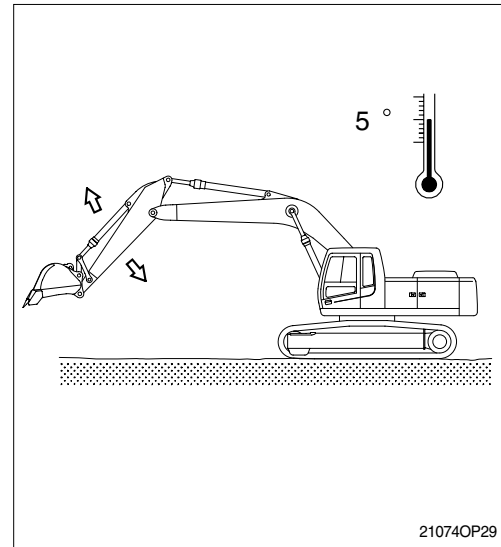

2) OPERATION IN SANDY OR DUSTY WORK SITES

- (1) Inspect air cleaner element frequently. Clean or replace element more frequently, if warning lamp comes ON and buzzer sounds simultaneously, regardless of inspection period.
※ **Replace the inner and outer element after 6 times of cleaning.**
- (2) Inspect radiator frequently, and keep cooling fins clean.
- (3) Prevent sand or dust from getting into fuel tank and hydraulic tank during refilling.
- (4) Prevent sand or dust from penetrating into hydraulic circuit by tightly closing breather cap of hydraulic oil tank. Replace hydraulic oil filter frequently.
- (5) Keep all lubricated part, such as pins and bushings, clean at all times.
- (6) If the air conditioner and heater filters clogged, the heating or cooling capacity will drop. Clean or replace the filter element more frequently.

5) BOOM CYLINDER

Mark	Description	Unit	Specification
L	Length	mm(ft-in)	2300(7' 7")
H	Height	mm(ft-in)	350(1' 2")
W	Width	mm(ft-in)	425(1' 5")
Wt	Weight(2EA)	kg(lb)	680(1500)

※ Included piping.

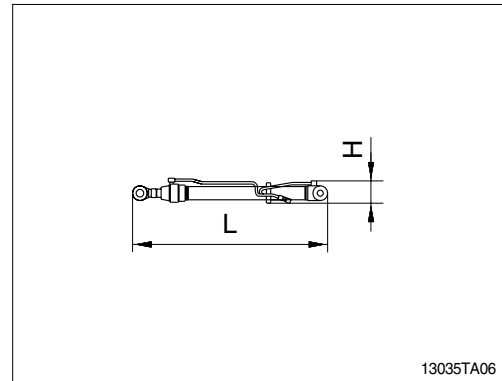

6) CAB ASSEMBLY

Mark	Description	Unit	Specification
L	Length	mm(ft-in)	1962(6' 4")
H	Height	mm(ft-in)	1676(5' 5")
W	Width	mm(ft-in)	1288(4' 2")
Wt	Weight	kg(lb)	310(680)

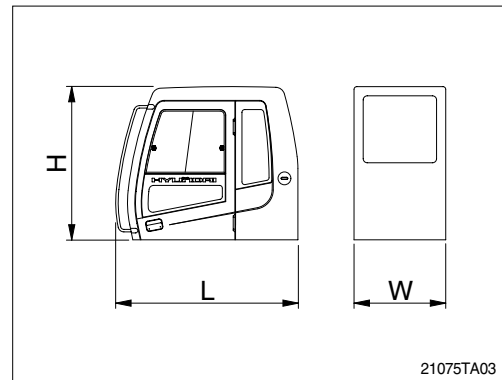

7) COUNTERWEIGHT

Mark	Description	Unit	Specification
L	Length	mm(ft-in)	2980(9' 9")
H	Height	mm(ft-in)	1165(3' 10")
W	Width	mm(ft-in)	630(2' 1")
Wt	Weight	kg(lb)	6500(14330)

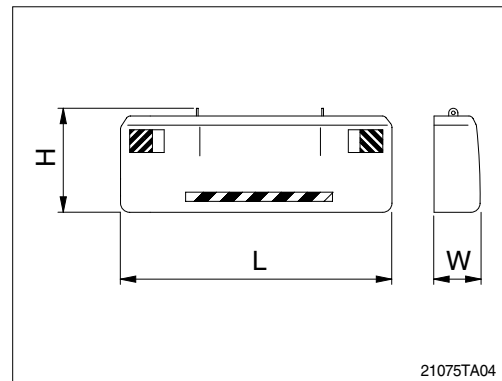

2. TIGHTENING TORQUE

Use following table for unspecified torque.

1) BOLT AND NUT

(1) Coarse thread

Bolt size	8T		10T	
	kgf · m	lbf · ft	kgf · m	lbf · ft
M 6 × 1.0	0.85 ~ 1.25	6.15 ~ 9.04	1.14 ~ 1.74	8.2 ~ 12.6
M 8 × 1.25	2.0 ~ 3.0	14.5 ~ 21.7	2.7 ~ 4.1	19.5 ~ 29.7
M10 × 1.5	4.0 ~ 6.0	28.9 ~ 43.4	5.5 ~ 8.3	39.8 ~ 60.0
M12 × 1.75	7.4 ~ 11.2	53.5 ~ 81.0	9.8 ~ 15.8	70.9 ~ 114
M14 × 2.0	12.2 ~ 16.6	88.2 ~ 120	16.7 ~ 22.5	121 ~ 163
M16 × 2.0	18.6 ~ 25.2	135 ~ 182	25.2 ~ 34.2	182 ~ 247
M18 × 2.0	25.8 ~ 35.0	187 ~ 253	35.1 ~ 47.5	254 ~ 344
M20 × 2.5	36.2 ~ 49.0	262 ~ 354	49.2 ~ 66.6	356 ~ 482
M22 × 2.5	48.3 ~ 63.3	349 ~ 458	65.8 ~ 98.0	476 ~ 709
M24 × 3.0	62.5 ~ 84.5	452 ~ 611	85.0 ~ 115	615 ~ 832
M30 × 3.0	124 ~ 168	898 ~ 1214	169 ~ 229	1223 ~ 1656
M36 × 4.0	174 ~ 236	1261 ~ 1704	250 ~ 310	1808 ~ 2242

(2) Fine thread

Bolt size	8T		10T	
	kgf · m	lbf · ft	kgf · m	lbf · ft
M 8 × 1.0	2.2 ~ 3.4	15.9 ~ 24.6	3.0 ~ 4.4	21.7 ~ 31.8
M10 × 1.2	4.5 ~ 6.7	32.5 ~ 48.5	5.9 ~ 8.9	42.7 ~ 64.4
M12 × 1.25	7.8 ~ 11.6	56.4 ~ 83.9	10.6 ~ 16.0	76.7 ~ 116
M14 × 1.5	13.3 ~ 18.1	96.2 ~ 131	17.9 ~ 24.1	130 ~ 174
M16 × 1.5	19.9 ~ 26.9	144 ~ 195	26.6 ~ 36.0	192 ~ 260
M18 × 1.5	28.6 ~ 43.6	207 ~ 315	38.4 ~ 52.0	278 ~ 376
M20 × 1.5	40.0 ~ 54.0	289 ~ 391	53.4 ~ 72.2	386 ~ 522
M22 × 1.5	52.7 ~ 71.3	381 ~ 516	70.7 ~ 95.7	511 ~ 692
M24 × 2.0	67.9 ~ 91.9	491 ~ 665	90.9 ~ 123	658 ~ 890
M30 × 2.0	137 ~ 185	990 ~ 1339	182 ~ 248	1314 ~ 1796
M36 × 3.0	192 ~ 260	1390 ~ 1880	262 ~ 354	1894 ~ 2562

5. MAINTENANCE CHART

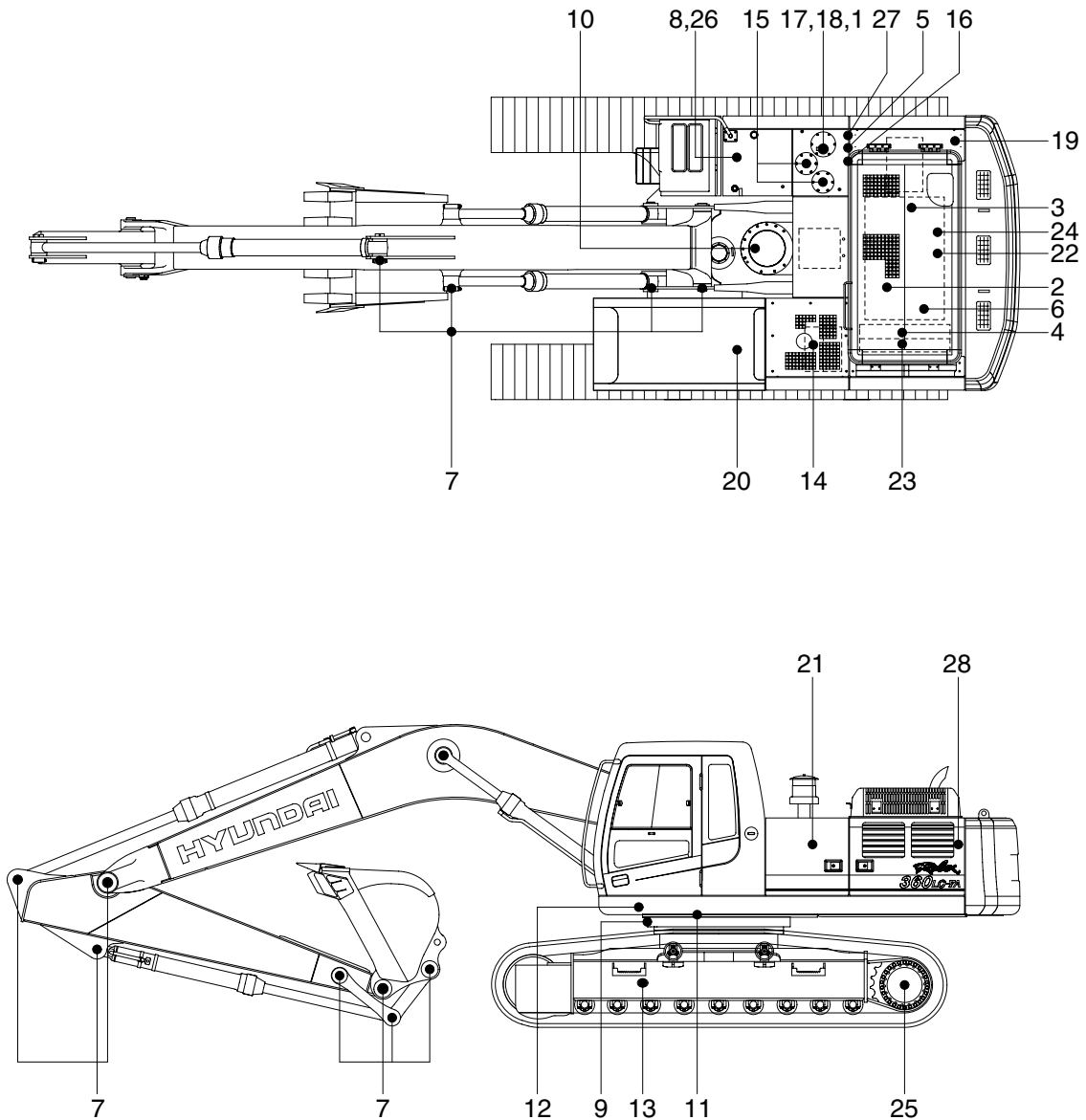

3607A6MI05

Caution

1. Service intervals are based on the hour meter reading.
2. The number of each item shows the lubrication point on the machine.
3. Stop engine while filling oil, and use no open flames.
4. For other details, refer to the service manual.

10) BELT TENSIONER, AUTOMATIC Adjustment

- (1) Every 1000hours, or 1 year, whichever occurs first, inspect the automatic belt tensioner.

With the engine turned off, check that neither the top nor bottom tensioner arm stop is touching the cast boss on the tensioner body. If either of the stops is touching a boss, the alternator belt must be replaced. Check to make sure the correct belt part number is being used if either condition exists.

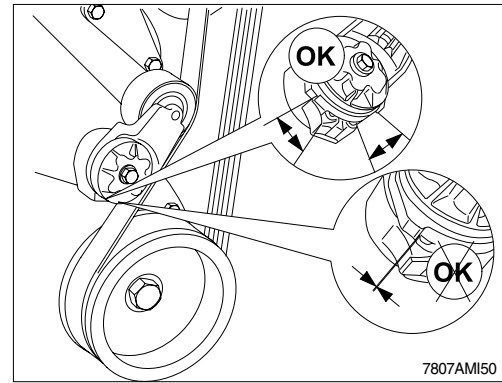

- (2) Check the tensioner pulley and body for cracks. If any cracks are noticed, the tensioner must be replaced. Refer to a Cummins Authorized Repair facility. Check the tensioner for dirt buildup. If this condition exists, the tensioner must be removed and steam-cleaned.

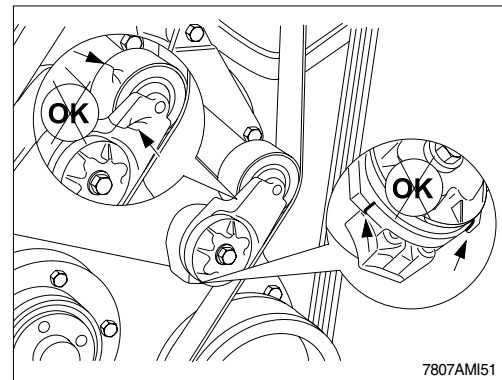

- (3) Check that the bottom tensioner arm stop is in contact with the bottom tensioner arm stop boss on the tensioner body. If these two are not touching, the tensioner must be replaced.

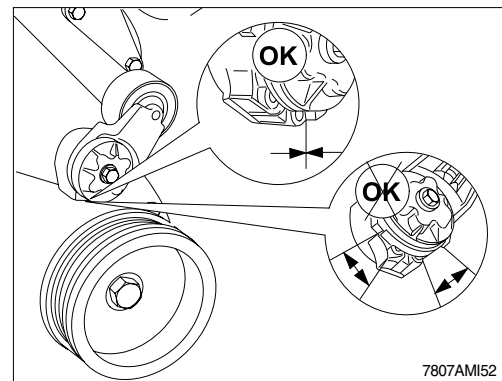

- (4) Inspect the tensioner for evidence of the pivoting tensioner arm contacting the stationary circular base. If there is evidence of these two areas touching, the pivot tube bushing has failed and the tensioner must be replaced.

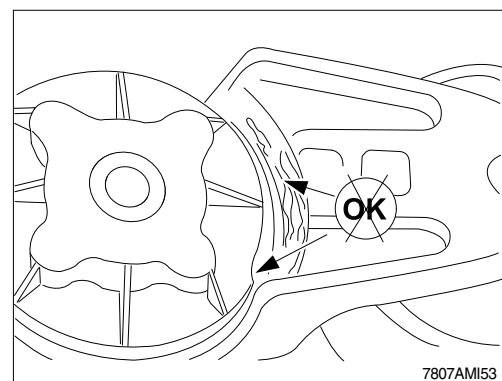

31) LUBRICATE RCV LEVER

Remove the bellows and with a grease gun grease the joint part(A) and sliding parts(B).

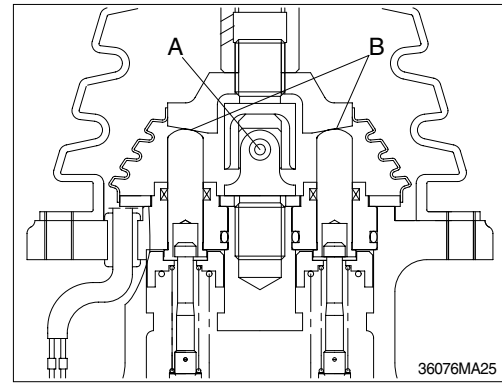

32) ADJUSTMENT OF TRACK TENSION

- ※ It is important to adjust the tension of track properly to extend the lifetime of track and traveling device.
- ※ The wear of pins and bushings on the undercarriage will vary with the working conditions and soil properties.
It is thus necessary to continually inspect the track tension so as to maintain the standard tension on it.

- (1) Raise the chassis with the boom and arm.
 - (2) Measure the distance between bottom of track frame on track center and track of shoe.
- ※ **Remove mud with rotating the track before measuring.**

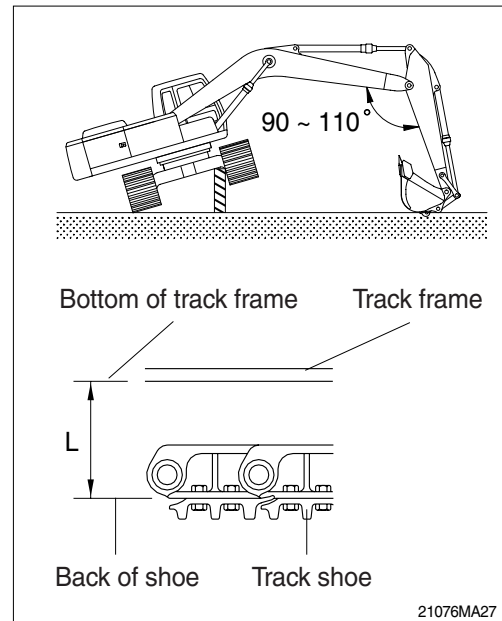

- (3) If the tension is tight, drain the grease in the grease nipple and if the tension is loose, charge the grease.

- ▲ **Personal injury or death can result from grease under pressure.**
- ▲ **When loosening the grease nipple, do not loosen more than one turn as there is a danger of a spring coming out of the nipple because of the high pressure inside.**
- ※ **When the grease is drained, move the track to the forward and backward slightly.**
If the track tension is loose even after the grease is charged to the maximum, change the pins and bushings as there are worn seriously.

Working condition	Length(L)	
	General	390~420mm
Swamp	420~460mm	16.5~18.1"
Sand, Mud, pebbes	About 460mm	About 18.1"

TROUBLESHOOTING GUIDE

1. ENGINE

- ※ This guide is not intended to cover every conditions, however many of the more common possibilities are listed.
- ※ When fault codes(3digit) are displayed on the monitoring display, consult cummins for details.

Trouble	Service	Remark
The engine oil pressure lamp lights ON when engine speed is raised after completion of warm up.	<ul style="list-style-type: none"> • Add the oil to the specified level. • Replace the oil filter cartridge. • Check oil leakage from the pipe or the joint. • Replace the monitor. 	
Steam is emitted from the top part of the radiator(The pressure valve). Coolant level warning lamp lights ON.	<ul style="list-style-type: none"> • Supply the coolant and check leakage. • Adjust fan belt tension. • Wash out inside of cooling system. • Clean or repair the radiator fin. • Check the thermostat. • Tighten the radiator cap firmly or replace the packing of it. • Replace the monitor. 	
The engine does not start when the starting motor is turned over.	<ul style="list-style-type: none"> • Add fuel. • Repair where air is leaking into fuel system. • Check the injection pump or the nozzle. • Check the valve clearance. • Check engine compression pressure. 	
Exhaust gas is white or blue.	<ul style="list-style-type: none"> • Adjust to specified oil quantity. • Replace with specified fuel. 	
Exhaust gas occasionally turns black.	<ul style="list-style-type: none"> • Clean or replace the air cleaner element. • Check the nozzle. • Check engine compression pressure. • Clean or replace the turbocharger. 	
Combustion noise occasionally changes to breathing sound.	<ul style="list-style-type: none"> • Check the nozzle. 	
Unusual combustion noise or mechanical noise.	<ul style="list-style-type: none"> • Check with specified fuel. • Check over-heating • Replace the muffler. • Adjust valve clearance. 	

CLICK HERE TO **DOWNLOAD** THE COMPLETE MANUAL

- Thank you very much for reading the preview of the manual.
- You can download the complete manual from: www.heydownloads.com by clicking the link below



- Please note: If there is no response to CLICKING the link, please download this PDF first and then click on it.

CLICK HERE TO **DOWNLOAD** THE COMPLETE MANUAL