

FOREWORD

This manual contains a number of instructions and safety recommendations regarding driving, handling, lubrication, maintenance, inspection and adjustment of the skid steer loader. The manual is to promote safety maintenance and enhance machine performance.

Keep this manual handy and have all personnel read it periodically.

If you sell the machine, be sure to give this manual to the new owners.

This machine complies with EC directive "2006/42/EC".

1. **Read** and **understand** this manual before operating the machine.

This operator's manual may contain attachments and optional equipment that are not available in your area. Please consult your local Hyundai distributor for those items you require.

Improper operation and maintenance of this machine can be hazardous and could result in serious injury or death.

Some actions involved in operation and maintenance of the machine can cause a serious accident, if they are not done in a manner described in this manual.

The procedures and precautions given in this manual apply only to intended uses of the machine. If you use your machine for any unintended uses that are not specifically prohibited, you must be sure that it is safe for you and others. In no event should you or others engage in prohibited uses of actions as described in this manual.

2. **Inspect** the jobsite and **follow** the safety recommendations in the **safety hints** section before operating the machine.

3. Use **genuine Hyundai spare parts** for the replacement of parts.

We expressly point out that Hyundai will not accept any responsibility for defects resulting from non-genuine parts or non workmanlike repair.

In such cases Hyundai cannot assume liability for any damage.

Continuing improvements in the design of this machine can lead to changes in detail which may not be reflected in this manual. Consult Hyundai or your Hyundai distributor for the latest available information for your machine or for questions regarding information in this manual.

CLICK HERE TO **DOWNLOAD** THE COMPLETE MANUAL

- Thank you very much for reading the preview of the manual.
- You can download the complete manual from: www.heydownloads.com by clicking the link below



- Please note: If there is no response to CLICKING the link, please download this PDF first and then click on it.

CLICK HERE TO **DOWNLOAD** THE COMPLETE MANUAL

Foreword	0-1
Before servicing this machine	0-2
Table to enter S/No. and distribution	0-3
EC regulation approved	0-4
Safety label	0-5
Machine data plate	0-9
Guide(Direction, S/No., Symbol)	0-10

1. SAFETY HINTS

1. Before operating the machine	1-1
2. During operating the machine	1-5
3. During maintenance	1-12
4. Parking	1-16

2. SPECIFICATIONS

1. Major components	2-1
2. Specifications	2-2
3. Weight	2-3
4. Specification for major components	2-4

3. CONTROL DEVICES

1. Locations	3-1
2. Warning indicator panel	3-2
3. Operating levers and switches	3-6
4. Air conditioner and heater(Cab type)	3-11
5. Others	3-13

4. OPERATION

1. Suggestion for new machine	4-1
2. Check before starting the engine	4-2
3. Normal starting	4-3
4. Starting engine in a cold weather	4-4
5. Jump starting	4-5
6. To stop the engine	4-6

The engine angularity limits are 20 degree.
Do not operate by more than the engine limits in any case.

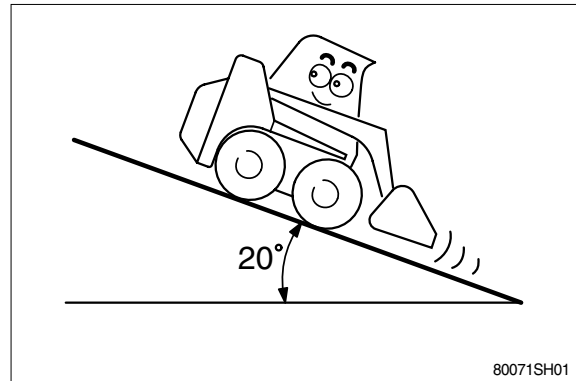

Watch out for obstacles. Be particularly careful to check the machine clearance during steering.

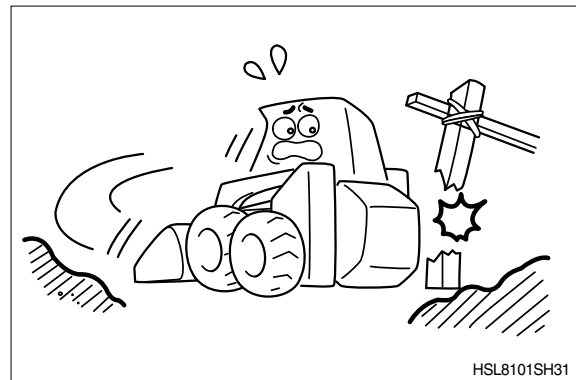

Always operate machine with proper ROPS/FOPS installed.
Do not attempt to repair a rollover protective structure(ROPS) after an accident.
Repaired structures do not provide the original structure and protection.
Test and approved as a protective CANOPY according to ROPS and FOPS standard.
Meets : ISO 3471/3449/3164
Meets :SAE J1040/J1043/J397

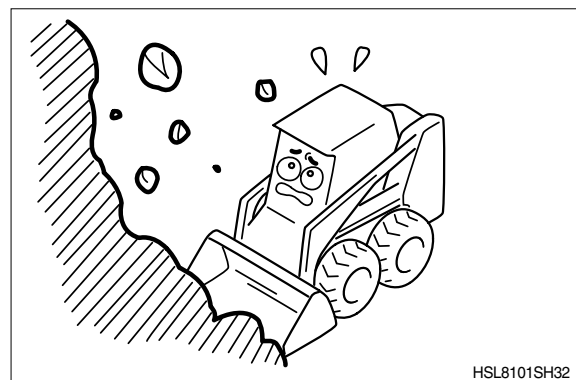

Avoid operating on a cliff, or soft ground as there is danger of rolling over.
Take necessary precautions when working after rain, or blasting because the ground may not be firm enough.

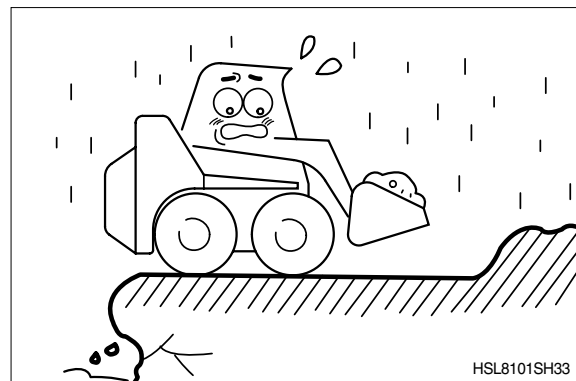

3. WEIGHT

Item	HSL650-7A	
	kg	lb
Frame assembly	760	1680
Canopy	164	362
Engine assembly	184	405
HST pump assembly (Pilot)	55	121
HST pump assembly (Mechanical)	45	99
Working pump	14	31
Main control valve	19	42
Travel motor	40	88
Boom	250	550
Bucket	170	375
Tire(10×16.5-6PR)	40	88
Boom cylinder	43	95
Bucket cylinder	24	53
Seat	9.6	21
Battery	20	44
Rear door assembly	58	128

2) BUZZER STOP SWITCH

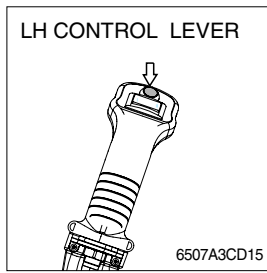

- (1) The buzzer sounds when the machine has a problem.
In this case, if the switch is pressed, the buzzer will be stopped. Be sure to check machine for problems.
- (2) Wait until the lamp is turned OFF, if the warning lamp lights ON after the buzzer stopped.
If not, stop engine and check the system.

3) WIPER SWITCH(Cab type, option)

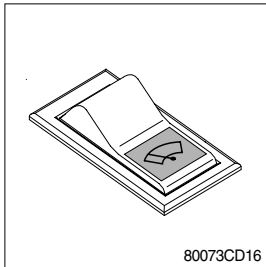

- (1) The switch is used to operate the wiper and washer by two step.
 - First step : The front wiper operates.
 - Second step : The washer liquid is sprayed and the front wiper is operated only while pressing. If release the switch, return to the first step position.
- (2) The below indicator lamp is turned ON when operating this switch.

4) MAIN LIGHT SWITCH

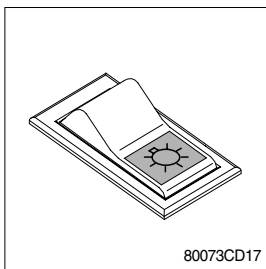

- (1) The switch is used to operate the front and rear work light.
 - First step : Front work lights, cigar light lamp and fuel gauge lamp comes ON.
 - Second step : Rear work light(Optional) comes ON.
- (2) The below indicator lamp is turned ON when operating this switch.

5) RESET SWITCH

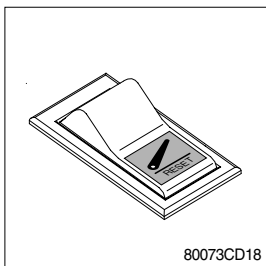

- (1) With seat belt secured, seat bar down and engine running, the operator must momentarily press the reset button before the loader boom raise/lower hydraulic system can be functional.
- (2) The loader boom raise/lower hydraulic system will remain active until the seat bar is raised or the start switch is turned OFF.

6) HEATER SWITCH(Cab type, option)

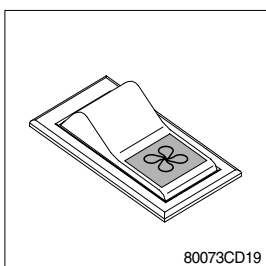

- (1) This switch is used to operate the heater.
- (2) The below indicator lamp is turned ON when operating this switch.

CLICK HERE TO **DOWNLOAD** THE COMPLETE MANUAL

- Thank you very much for reading the preview of the manual.
- You can download the complete manual from: www.heydownloads.com by clicking the link below



- Please note: If there is no response to CLICKING the link, please download this PDF first and then click on it.

CLICK HERE TO **DOWNLOAD** THE COMPLETE MANUAL

5) FUSE BOX

 HYUNDAI	안전 솔레노이드 SAFETY SOL. — 15A —
	엔진스톱 솔 옵션 CIGAR, OPTION — 20A —
	라이트 LIGHT — 25A —
	실내등, 계기판 ROOM & INDICATOR — 20A —
	옵션 OPTION — 20A —
	혼 HORN — 15A —

NOTE : USE THE DESIGNATED FUSE.
 PART NO(품번) : 21S4-01040
 PART NAME : 퓨즈박스 (FUSE BOX)

80073CD41

- (1) The fuses protect the electrical parts and wiring from burning out.
- (2) The fuse box cover indicates the capacity of each fuse and circuit it protects.

※ Replace a fuse with another of the same capacity.

▲ Before replacing a fuse, be sure to turn OFF the starting switch.

6) CONTROL UNIT

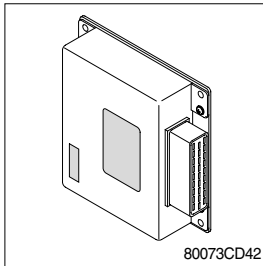

80073CD42

- (1) It consists of electronic parts and controls all lamps and buzzers on indicator panel in accordance with signals transmitted from the switches, the engine and the hydraulic pressure sensors.

7) EMERGENCY EXIT

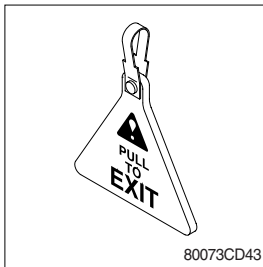

80073CD43

- (1) The front opening on the operator cab and rear window provide exits.
- (2) To exit through the rear window, use the following procedure.
 - ① Pull on the tag at the rear window to remove the rubber cord.
 - ② Push the rear window out of the rear of the operation cab.
 - ③ Exit through the rear of the cab.

8) HOLD REAR DOOR IN OPENING

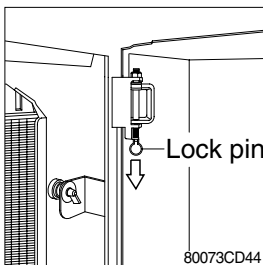

80073CD44

- (1) Open the rear door fully(about 95°), then the rear door is hold automatically by lock pin and pull down the lock pin to close the rear door.

9. MACHINE OPERATION

1) STARTING

- (1) Push the throttle lever forward to raise the engine speed.
- (2) Operate the control lever to raise the bucket to 20~30cm(1ft) above the ground.
- (3) Operate the loader at high engine speed.

2) STRAIGHT FORWARD

Push both control levers forward from the centered(Neutral) position the same distance. The further the levers are away from the neutral position, the faster the travel speed.

3) STRAIGHT BACKWARD(Reverse)

Pull both control levers backward from the centered(Neutral) position the same distance. The further the levers are away from the neutral position, the faster the travel speed.

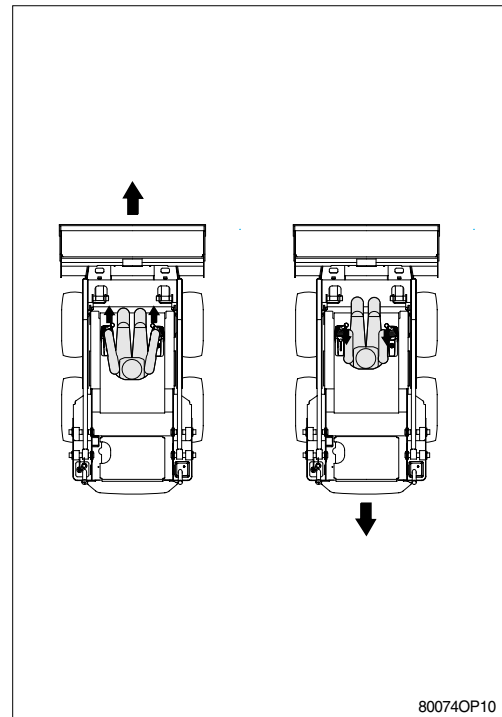

4) SLOW TURN

Varying shift distances of the left and right control levers during forward or backward traveling makes the machine slowly turn to the side where the shift distance is smaller.

The greater the difference between the shift distance of the two levers, the smaller the turning radius. The smaller the difference, the greater the turning radius.

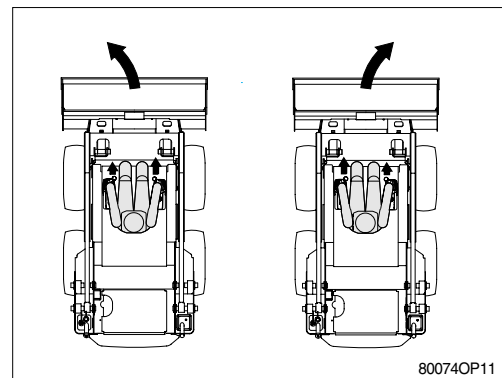

5) PIVOT TURN

Operating only the left one of the two control levers makes the machine turn with the right tires as the center. Operating the right lever causes a left turn around the left tires.

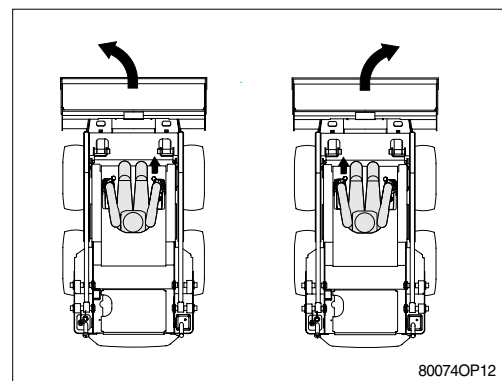

3) GRADING AND LEVELING

The bucket is tilted forward and raised slightly off the ground to perform grading and leveling jobs.

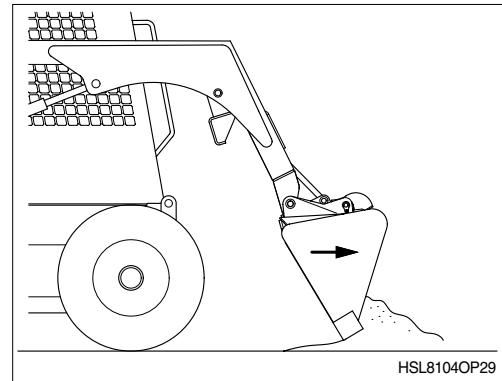

4) FILLING

Hole filling and similar operations are possible.

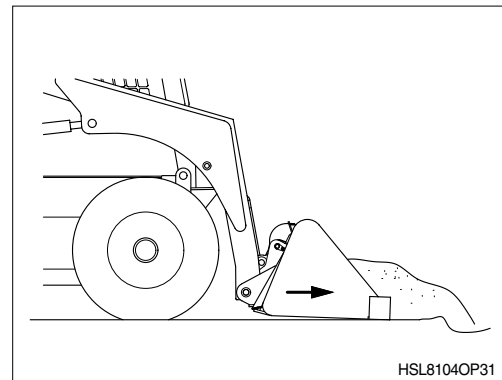

5) BACKFILLING

Backfilling can be done by tilting the bucket forward and backing up with the edge slightly off the ground.

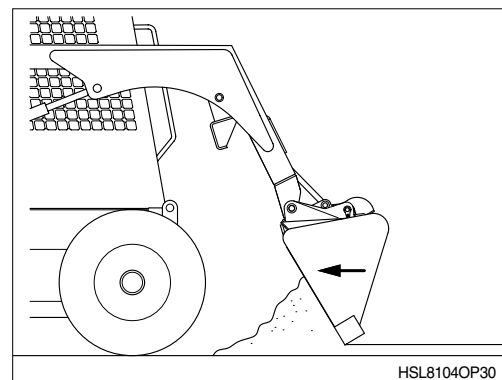

6) FLOAT POSITION

It is sometimes easier to work the boom in the float position.

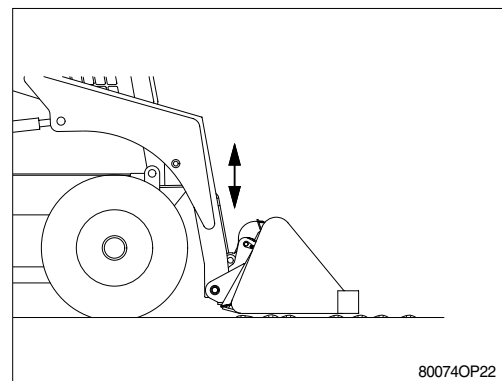

2. GENERAL MAINTENANCE

▲ Do not perform service or maintenance on the loader with the engine running. Contact with moving parts can cause injury or death.

SAFETY CHECK LIST

Inspect the following safety equipment daily.

1) SEAT BELT

Check for frayed and cut webbing, damaged buckles, or loose mounting brackets.

2) ROLL OVER PROTECTIVE STRUCTURE(ROPS)

Check for damage or loose mountings. If the ROPS has been damaged, replacement must be made only by and authorized Hyundai dealer.

3) SAFETY TREADS

Keep treads clean. Replace if worn, damaged, or missing.

4) SHIELDS

Keep all protective shields in place.

5) SEAT BAR

Check operation.

6) ATTACHMENT ASSEMBLY

Make sure assembly is pinned securely to the tilt cylinder and boom.

If an attachment is installed, check that lock pins are inserted completely into the attachment.

7) BOOM LOCKS

Check operation.

8) OPERATING LIGHTS

Turn the light switch to the right to **First step** and **Second step** and check operation of work lights.

Replace any that are not functional.

9) ENGINE

Check cleanliness.

Remove all dirt or debris and all flammable material before running the engine.

3) REPLACING ENGINE OIL FILTER CARTRIDGE

▲ Do not stop the engine suddenly, stop it after about 5 minutes of unload idling.

※ Be sure to stop the engine before replacing filter cartridge.

▲ Allow engine to cool down sufficiently, oil can be hot and cause burns.

- (1) Remove the oil filter old cartridge with the filter wrench.
- (2) Apply a slight coat of oil onto the new cartridge gasket.
- (3) To install the new cartridge, screw it in by hand. Over tightening may cause deformation of rubber gasket.
- (4) After the new cartridge has been replaced, the engine oil normally decrease a little. Thus see that the engine oil does not leak through the seal and be sure to read the oil level on the dipstick. Then, replenish the engine oil up to the specified level.

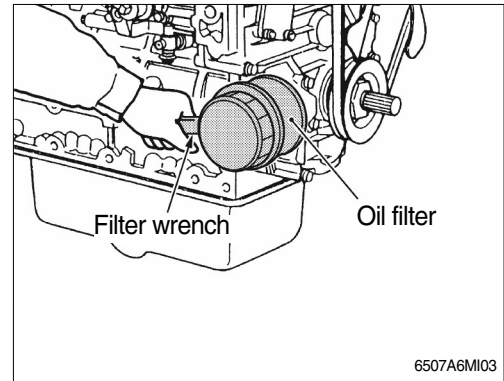

4) CHECK RADIATOR COOLANT

(1) To check coolant level open the rear door. Check to see that the coolant level lies between **FULL** and **LOW**.

(2) If coolant level is too low, fill clean water into the radiator.

(3) Replace gasket of radiator cap when it is damaged.

※ Hot coolant can spray out if radiator cap is removed while engine is hot. Remove the cap after the engine has cooled down.

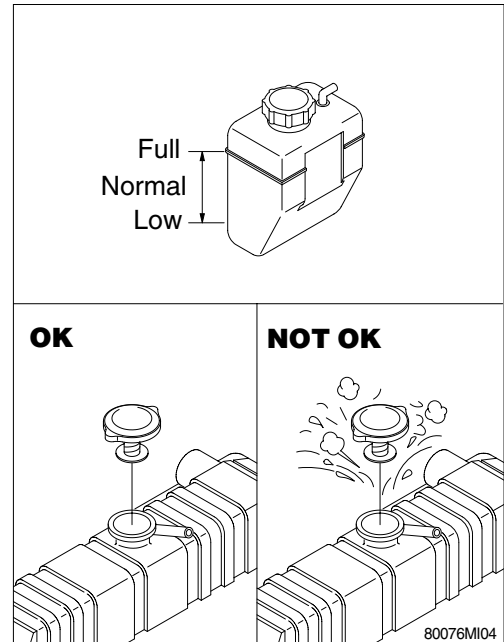

20) FINAL DRIVE CHAIN CASE OIL

(1) Level check

- ① Lower the boom ground any attachment, and shut the engine off.
- ② Remove the check/fill plug between the two tires.
- ③ If oil can be detected by inserting a finger through the check/fill plug opening, the level is satisfactory. If not, add specified oil as required through the same plug opening.
- ④ Install the check/fill plug.
- ⑤ Repeat the procedure for other drive housing.

(2) Oil change

- ① Lower the boom ground any attachment, and shut the engine off.
- ② Remove the check/fill plug and the drain plug and allow oil to drain from the housing into a receptacle.
- ③ Install the drain plug.
- ④ Add specified oil through the check/fill plug opening to the level of the plug opening. Capacity for each drive housing is 9.2 liters.
- ⑤ Install the check/fill plug. Repeat the procedure for the other drive housing.

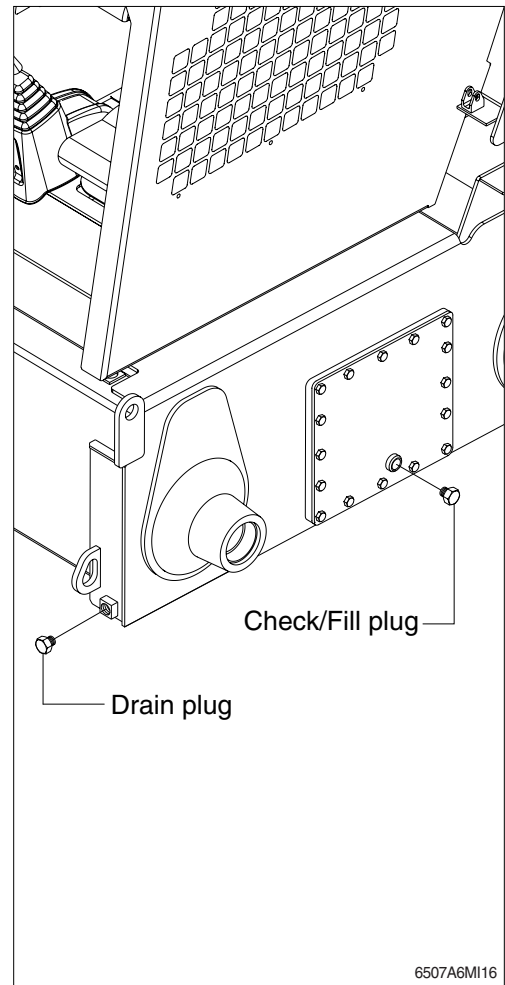

CLICK HERE TO **DOWNLOAD** THE COMPLETE MANUAL

- Thank you very much for reading the preview of the manual.
- You can download the complete manual from: www.heydownloads.com by clicking the link below



- Please note: If there is no response to CLICKING the link, please download this PDF first and then click on it.

CLICK HERE TO **DOWNLOAD** THE COMPLETE MANUAL