

# CONTENTS

EC declaration of conformity .....	0-1	9. Operation in the special work sites .....	4-23
Foreword .....	0-2	10. Storage .....	4-25
Emission-related components warranty (USA and CANADA only) .....	0-2-1	11. Exhaust system cleaning .....	4-27
Before servicing this machine .....	0-3	12. Open the engine hood .....	4-28
Table to enter S/No and distribution .....	0-4	13. Attachment manually lowering .....	4-31
EC regulation approved .....	0-5		
Safety labels .....	0-6	<b>5. TRANSPORTATION</b>	
Machine data plate .....	0-16	1. Road traveling .....	5-1
Guide (direction, S/No, symbol) .....	0-17	2. Preparation for transportation .....	5-2
		3. Loading the machine .....	5-3
<b>1. SAFETY HINTS</b>		4. Fixing the machine .....	5-4
1. California proposition 65 .....	1-1	5. Loading and unloading by crane .....	5-6
2. Safety rules .....	1-2	6. Towing the machine .....	5-7
<b>2. SPECIFICATIONS</b>		<b>6. MAINTENANCE</b>	
1. Major components .....	2-1	1. Instructions .....	6-1
2. Specifications .....	2-2	2. Tightening torque .....	6-5
3. Weight .....	2-6	3. Spec of fuel, coolant and lubricants .....	6-8
4. Specification for major components .....	2-7	4. Maintenance check list .....	6-10
<b>3. CONTROL DEVICES</b>		5. Maintenance chart .....	6-13
1. Cab devices .....	3-1	6. Service instruction .....	6-15
2. Cluster .....	3-2	7. Electrical system .....	6-49
3. Monitors .....	3-13	8. Air conditioner and heater .....	6-52
4. Switches .....	3-44	<b>7. TROUBLESHOOTING GUIDE</b>	
5. Control device .....	3-49	1. Engine .....	7-1
6. Air conditioner and heater .....	3-53	2. Electrical system .....	7-2
7. Others .....	3-56	3. Power train system .....	7-3
<b>4. OPERATION</b>		4. Hydraulic system .....	7-4
1. Suggestion for new machine .....	4-1	<b>8. OTHERS</b>	
2. Check before starting the engine .....	4-2	1. Quick coupler .....	8-1
3. Starting and stop the engine .....	4-3	<b>INDEX</b> .....	9-1
4. Warming-up operation .....	4-8		
5. Operation of the working device .....	4-9		
6. Traveling of the machine .....	4-10		
7. Efficient working method .....	4-15		
8. Adjustment of the work equipment .....	4-22		

CLICK HERE TO **DOWNLOAD** THE COMPLETE MANUAL

- Thank you very much for reading the preview of the manual.
- You can download the complete manual from: [www.heydownloads.com](http://www.heydownloads.com) by clicking the link below



- Please note: If there is no response to CLICKING the link, please download this PDF first and then click on it.

CLICK HERE TO **DOWNLOAD** THE COMPLETE MANUAL

**9) ENGINE START CAUTION (item 13)**

This warning label is positioned on the rear side window of the cab.

- ▲ **Study the operator's manual before starting and operating machine.**

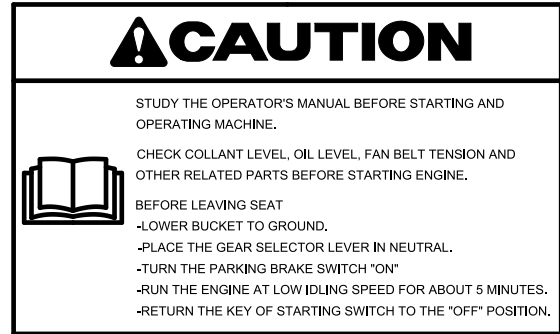

77070FW08

**10) CONTROL IDEOGRAM (item 14)**

This warning label is positioned on the right side window of the cab.

- ▲ **Confirm the operation of control lever and working device before operating the machine.**

※ Refer to the page 4-9 for details.

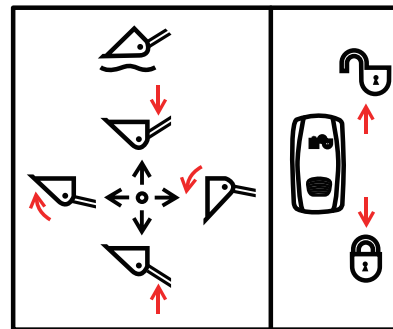

74090FW04

**11) AIR CONDITIONER FILTER (item 15)**

This warning label is positioned on the air-conditioner filter.

- ※ **Periodic and proper inspection, cleaning and change of filter prolong air conditioner life time and maintain good performance.**

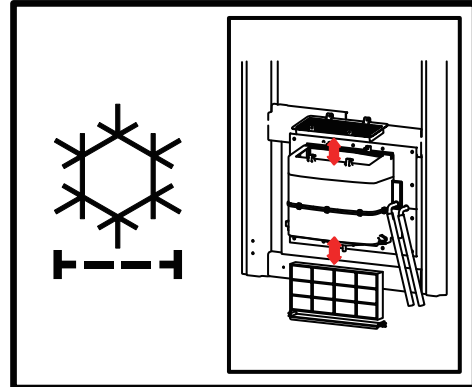

760F0FW10

**12) ELECTRIC WELDING (item 16)**

This warning label is positioned on the side of the battery box.

- ▲ **Before carrying out any electric welding on this machine**

- Pull the connectors out of all electronic control units.
- Connect the ground lead of the welding equipment as close to the welding point as possible.

※ Refer to the page 6-50 for details.

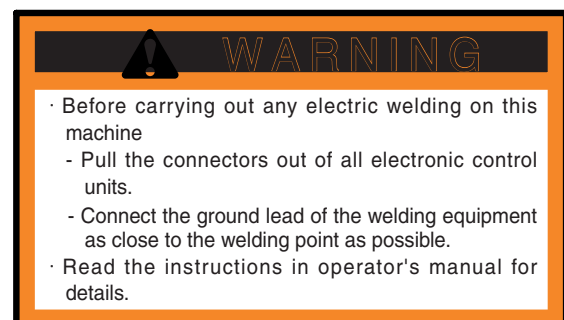

7803AFW20

## 1. CALIFORNIA PROPOSITION 65



### **WARNING**

#### CALIFORNIA PROPOSITION 65

Breathing diesel engine exhaust exposes you to chemicals known to the State of California to cause cancer and birth defects or other reproductive harm.

- Always start and operate the engine in a well-ventilated area.
- If in an enclosed area, vent the exhaust to the outside.
- Do not modify or tamper with the exhaust system.
- Do not idle the engine except as necessary.

For more information go to [www.P65warnings.ca.gov/diesel](http://www.P65warnings.ca.gov/diesel).

### **When handling coolants**

After operation of the machine the coolant is of high temperature and high pressure, and is retained inside the engine radiator and the heater line. Direct contact of the skin with the coolant may result in serious burns. Open the cap of the radiator only after the engine has sufficiently cooled and the pressure has reduced to a safe level.



Coolant contains toxic and combustible ethylene glycol, and should be handled in a cool, well-ventilated place only when wearing protective goggles, protective gloves, protective clothing, and a gas mask.



Avoid inhaling airborne particles or spray from coolant. If the substances make contact with skin or eyes that are not protected by personal protection gear, immediately wash the skin and eye with flowing water for 20 minutes or longer.

### **When working in a place subject to airborne particles and falling objects,**

Make sure you wear a safety helmet, protective goggles and safety shoes to prevent injury from such particles and objects. Earplugs or earmuffs may be necessary when working in a noisy place.



### **When working in places with a high level of noise**

When the operator is exposed to the noise exceeding 90 dB (A) for 8 hours or longer, wear earplugs or earmuffs.



## Cautions to Be Taken When Driving the Machine

- If you operate the machine with the parking brake on, it may cause serious damage to the parking brake disk.
- Select the appropriate gear for the driving speed.
- Do not change direction when driving the machine at max. speed as this may cause serious damage to the transmission.
- Only drive the machine for short distances on the road.
- Make sure you fully comply with the local road traffic regulations and legislation of your country when driving on the road.
- Please note that the machine is wider and travels at a lower driving speed than other vehicles on the roads.
- Pay attention to any vehicles behind your vehicle, and allow them to overtake your vehicle safely.
- Check the following conditions before driving the machine on the public road :
  - Remove any dirt and sand from the machine.
  - Empty the bucket and move it to the driving position (40~50 cm above the ground) and fix it.
  - Close the windshield. Turn the working light off.
  - Wear the seat belt.
  - Use the lighting devices, such as the headlights, emergency warning light and rotating beacon, pursuant to the local road traffic legislation.
  - Pay attention to people in the vicinity of the machine.
  - Do not operate the machine on roads or bridges where the machine exceeds the weight limit.
  - Familiarize yourself fully with the width, length and height of the machine.
  - Check the tire pressure.
  - When traveling for a long distance, stop the machine after every 40 km or on an hourly basis, and take a break.
  - Check the level of fuel and coolant.
  - Never shift the gear to the neutral position when driving down a slope.
  - Changing direction when operating the machine on a slope is dangerous.
  - Do not drive on a slope of 30° or more.
  - Drive slowly when traveling the machine on rough terrain or moving over obstacles.
  - Install chains on the tires when operating the machine on slippery roads covered with snow or rainwater, and do not attempt to start, stop or turn the machine suddenly.
  - Be sure to avoid any obstacles when traveling the machine on paths.

Driving position

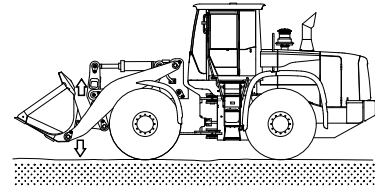

### Regular lubrication (during storage)

- Breaking the lubrication film on parts may cause abnormal abrasion during the next operation.
- Start up the engine once a month, perform all of the functions, and apply lubrication oil to every part.
- Check the level of the engine oil and coolant when starting the engine up, and top them up if necessary.
- Thoroughly wipe off any rust-proofing oil from the cylinder and piston rod.
- Sufficiently warm up the engine after starting the engine and repeat the operation of the attachments several times to wear in the parts sufficiently.
- Fully charge and store the battery.
- Store the battery separately for a long period of time under extremely cold weather conditions.
- Check the tire pressure.
- The machine shall not be lubricated manually while it is in motion where application of the lubricant may expose persons to injury.

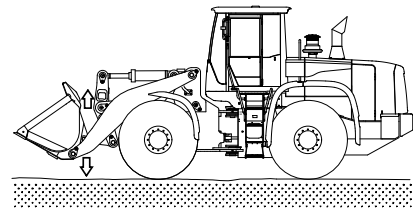

## 2) MAIN PUMP

Item	Specification
Type	Variable piston pump
Capacity	100 cc/rev
Maximum operating pressure	280 kgf/cm <sup>2</sup> (3980 psi)
Rated oil quantity (at 2200 rpm)	220ℓ/min (58.1 U.S.gpm / 48.4 U.K.gpm)
Maximum speed	2230 rpm

## 3) FAN AND BRAKE PUMP

Item	Specification
Type	Variable piston pump
Capacity	28 cc/rev
Maximum operating pressure	250 kgf/cm <sup>2</sup> (3560 psi)
Rated oil quantity (at 2200 rpm)	62ℓ/min (16.3 U.S.gpm)
Maximum speed	2230 rpm

## 4) MAIN CONTROL VALVE

Item	Specification
Type	3spool
Operating method	Hydraulic pilot assist
System pressure	280 kgf/cm <sup>2</sup> (3980 psi)
Overload relief valve pressure	340 kgf/cm <sup>2</sup> (4840 psi) / * : 150 kgf/cm <sup>2</sup> (2130 psi)

\* : Bucket dump

## 5) REMOTE CONTROL VALVE (EH TYPE)

Item	Specification
Type	Fingertip
Axle	Single axle for boom, bucket, auxiliary
Operating voltage	4.5~5.5 V
Output signal	0.5~4.5 V (neutral 2.5 V)

※ Manual exhaust system cleaning

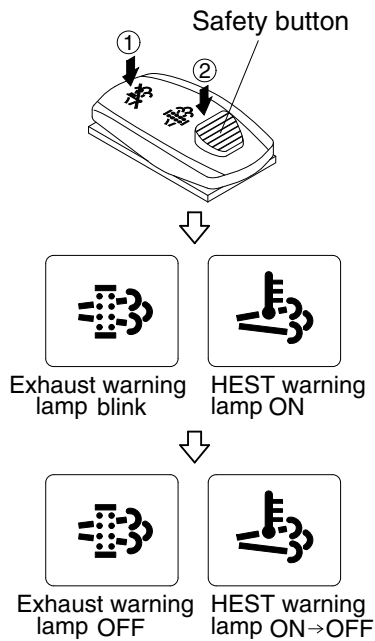

9753CD129A

※ Manual exhaust system cleaning applies if the machine is in a fireproof area.

※ To stop a manual exhaust system cleaning before it has completed, set to the exhaust system cleaning switch to the inhibit position or turn OFF the engine.

① Stop and park the machine.

② Pull the safety button and push the switch to position ② to initiate the manual exhaust system cleaning.

※ Refer to the page 3-46 for the exhaust system cleaning switch operation.

※ The engine speed may increase to 950~1050 rpm and exhaust system cleaning begins and it will take approximately 20~30 minutes.

③ The exhaust system cleaning warning lamp will blink and HEST warning lamp will light ON during the exhaust system cleaning is operating.

④ The exhaust system cleaning and/or HEST warning lamp will light OFF when the exhaust system cleaning is completed.

(18) HEST (High exhaust system temperature) warning lamp

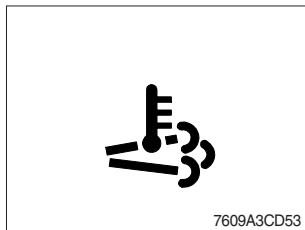

① This warning lamp indicates, when illuminated, that exhaust temperatures are high due to exhaust system cleaning.

② The lamp will also illuminate during a manual exhaust system cleaning.

③ When this lamp is illuminated, be sure the exhaust pipe outlet is not directed at any surface or material that can melt, burn, or explode.

▲ When this lamp is illuminated, the exhaust gas temperature could reach 800°C [1500°F], which is hot enough to ignite or melt common materials, and to burn people.

※ The lamp does not signify the need for any kind of equipment or engine service; It merely alerts the equipment operator to high exhaust temperatures. It will be common for the lamp to illuminate on and off during normal equipment operation as the engine completes exhaust system cleaning.

## (2) Mode

### ① Engine setting mode



- **Engine mode**

The operator can adjust the machine's performance.

- Econo : Maximum fuel efficiency for general loading.
- Power : Maximum power output for hard digging operation or hill climb.
- Smart power : Fuel efficient operation with same performance as power mode.

- **Engine speed**

Setting engine low idle rpm.

## ⑮ Electric steering speed setting (option)

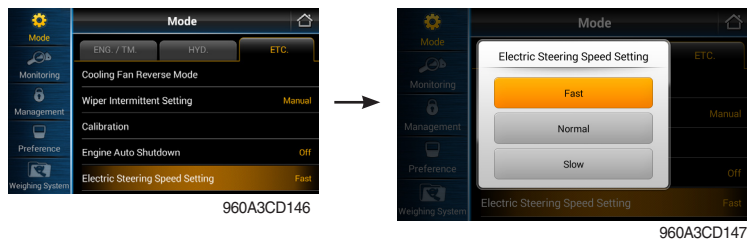

- This is a function that can adjust the electric steering speed in 3 steps (high/normal/low) only for equipment with electric steering option.
- ※ If step is changed during electric steering manipulation, the steering speed may change during steering, so it is recommended to operate in neutral state of the electric steering joystick (LH).
- ※ The electric steering speed setting function menu does not appear for equipment without electric steering option applied.

## ⑤ Camera setting

※ If the camera monitor is equipped, camera will showing on camera monitor only.

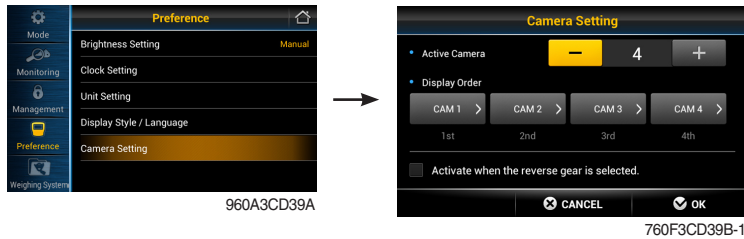

- **Active camera**
    - Four cameras can be installed on the machine.
  - **Display order**
    - Set the channel sequence of each camera.
  - **Active when the reverse gear is selected**
    - If transmission engages the reverse gear (R1~R3), the camera mode is displayed automatically in main display.
  - If the camera was not equipped, this menu is not useful.
  - If the camera monitor is equipped, camera will showing on camera monitor only. This menu is not useful. See the page 3-77.
  - In main display, if the is touched (or switch is pushed), the first ordered display camera will be viewed.
- ※ If AAVM is equipped, this menu will be changed to AAVM setting.

## ⑥ AAVM (Advance Around View Monitoring, option)

- ※ If the camera monitor is equipped, AAVM will showing on camera monitor only.
- The AAVM switches of the cluster consist of Camera, ESC and Buzzer stop.



- **Camera switch**
  - It will enter into the AAVM mode from the main display if the AAVM is installed.
  - If the camera monitor is equipped, AAVM will showing on camera monitor only. This menu is not useful. See the page 3-77.
  - While in the AAVM mode, select the ESC switch to return to the main display.



- **Buzzer stop switch**
  - In AAVM mode, it detects surrounding pedestrians or objects and the warning buzzer sounds.
  - User can turn OFF the warning sound by pressing buzzer stop switch.

## 4. SWITCHES

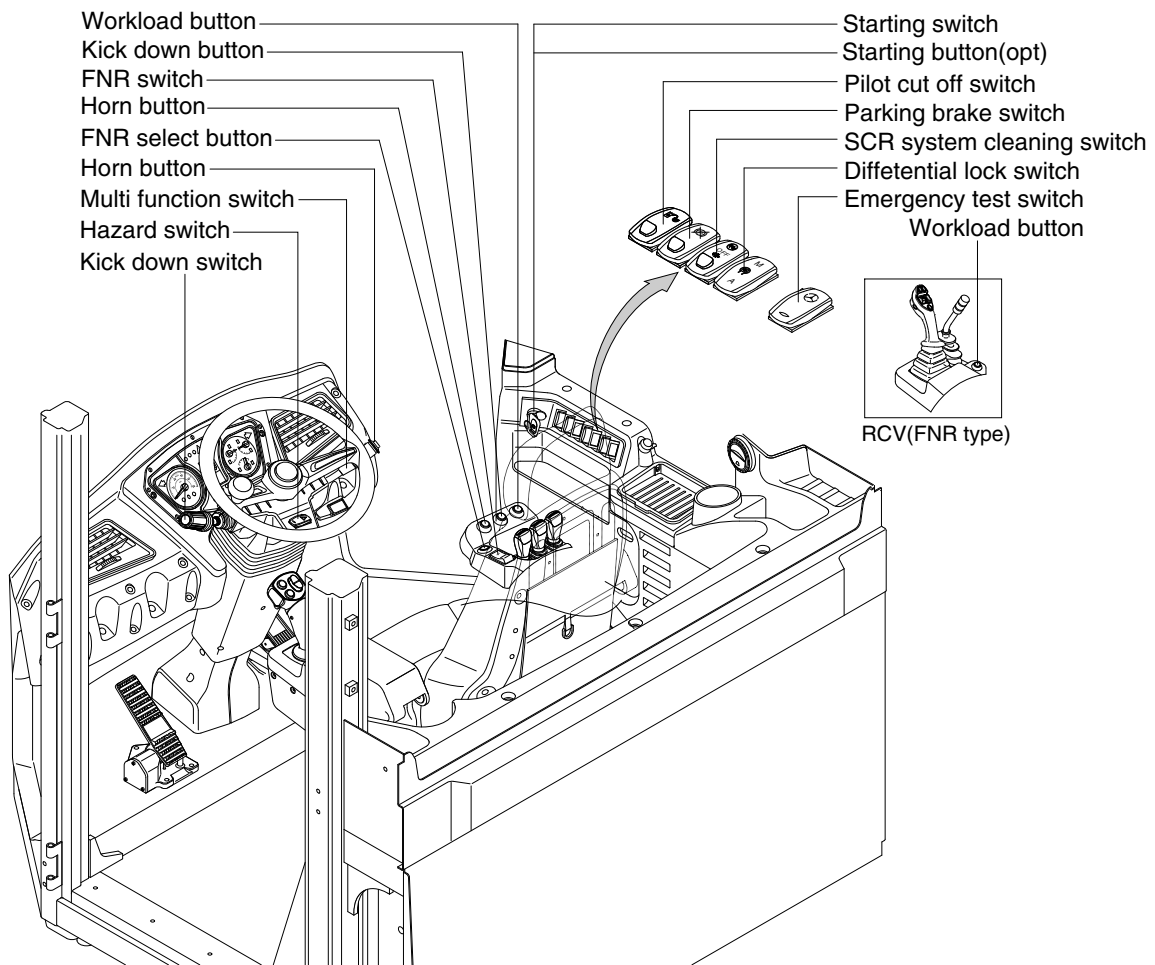

955TM3CD29

### 1) STARTING SWITCH & STARTING BUTTON (OPT)

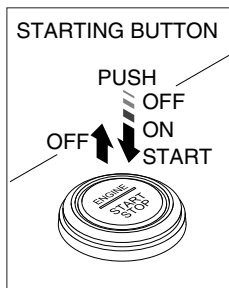
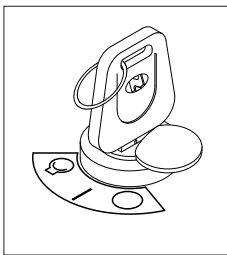

There are three positions, OFF, ON and START.

- ○ (OFF) : None of electrical circuits activate.
- | (ON) : All the systems of machine operate.
- ◯ (START) : Use when starting the engine.

Release key immediately after starting.

If you turn ON the starting switch in cold weather, the fuel warmer is automatically operated to heat the fuel by sensing the coolant temperature. Start the engine in 1~2 minutes after turning ON the starting switch. More time may take according to ambient temperature.

Key must be in the ON position with engine running maintain electrical and hydraulic function and prevent serious machine damage.

### 1) POWER SWITCH

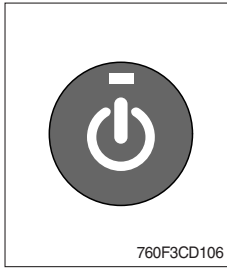

- (1) This switch makes the system ON or OFF.  
Just before the power OFF, set values are stored.

#### (2) Default setting values

Function	Air conditioner	In/outlet	Temperature
Value	OFF	Inlet	Previous sw OFF

※ The green pilot lamp is turned ON.

### 2) AUTO SWITCH

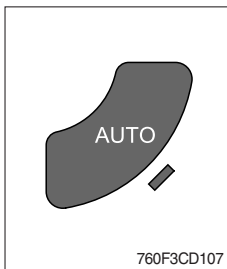

- (1) This switch sets the air conditioner and heater system to automatic temperature control.  
Auto air conditioner and heater system automatically keeps the optimum condition in accordance with operator's temperature configuration sensing ambient and cabin inside temperature.

※ The green pilot lamp is turned ON.

### 3) AIR CONDITIONER SWITCH (compressor switch)

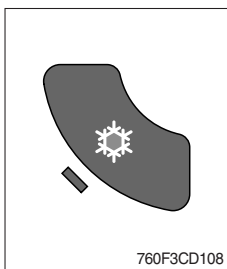

- (1) This switch turns the compressor for the air conditioning.  
(2) In accordance with the temperature sensed by duct (evaporator) sensor, compressor turns ON or OFF automatically.

※ Air conditioner operates to remove vapor and drains water through a drain hose. Water can be sprayed into the cab in case that the drain cock at the ending point of drain hose has a problem.

In this case, exchange the drain cock.

※ The green pilot lamp is turned ON.

### 4) DEFROSTER SWITCH

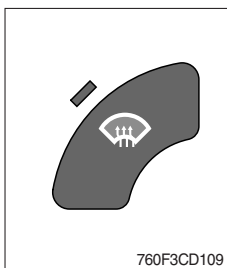

- (1) Defroster and ventilation nozzles at window open and directed toward the windows.

#### (2) Default setting values

Function	Air conditioner	In/outlet	Blower
Value	ON	Outlet	Max for 15 minutes

※ The green pilot lamp is turned ON.

CLICK HERE TO **DOWNLOAD** THE COMPLETE MANUAL

- Thank you very much for reading the preview of the manual.
- You can download the complete manual from: [www.heydownloads.com](http://www.heydownloads.com) by clicking the link below



- Please note: If there is no response to CLICKING the link, please download this PDF first and then click on it.

CLICK HERE TO **DOWNLOAD** THE COMPLETE MANUAL

### 10) MACHINE CONTROL UNIT

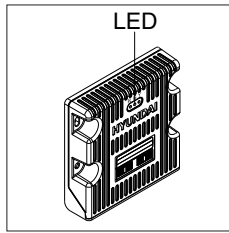

### 11) TRANSMISSION CONTROL UNIT (TCU)

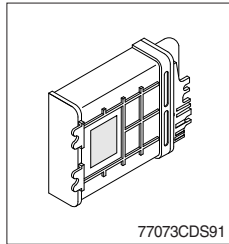

(1) The TCU uses sensors from the transmission, gear selector lever, as well as data provided by the ECU to calculate how and when to change gears.

### 12) ENGINE CONTROL MODULE (ECM)

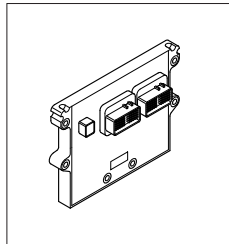

The engine control module (ECM) reads values from a multitude of sensors and adjusts engine output for optimal performance.

### 13) CONTROL UNIT

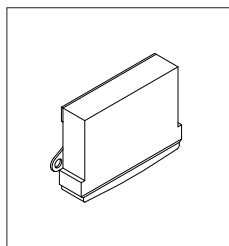

### 14) REAR CAMERA

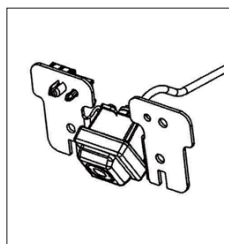

Refer to page 3-35.

## ■ BLUETOOTH (if equipped)

### 1) Using a bluetooth wireless connection

- (1) Your audio unit supports bluetooth wireless technology. You can set up a wireless link with bluetooth cellular phone.
  - (2) Keep PAIRING the cellular phone with audio unit in a few minutes as the phone are being switched on well enough.
- ※ Since this audio unit is on standby to connect with your cellular phone via bluetooth wireless technology, using this audio unit without running the engine can result battery drainage.
  - ※ This audio unit phone call reception is on standby when ignition switch is set to ACC OFF or ON.
  - ※ The line-of-sight distance between this audio unit and your cellular phone must be 10 meters or less for sending and receiving voice and data via bluetooth wireless technology. However the transmission distance may become shorter than the estimated distance depending on the environment in use.
  - ※ Digital Noise & Echo suppression system provides the best sound clarity with little or no distortion (Echo & side tone will happen depending on cellular phone or service network).
  - ※ To ensure the quality of calling, you should select a proper bluetooth VR level. This audio unit has already set with the best bluetooth VR level.

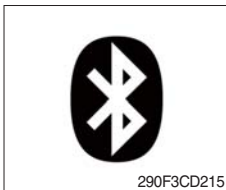

#### ① Bluetooth icon

It will blink while establishing the bluetooth pairing.  
It will light after a bluetooth device connected.

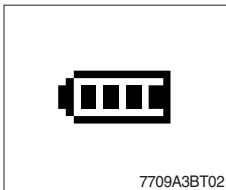

#### ② Battery icon

It indicates the battery status of the connected bluetooth device.



#### ③ Single strength icon

It indicates the signal strength of the connected bluetooth device.

(5) AAVM view mode type

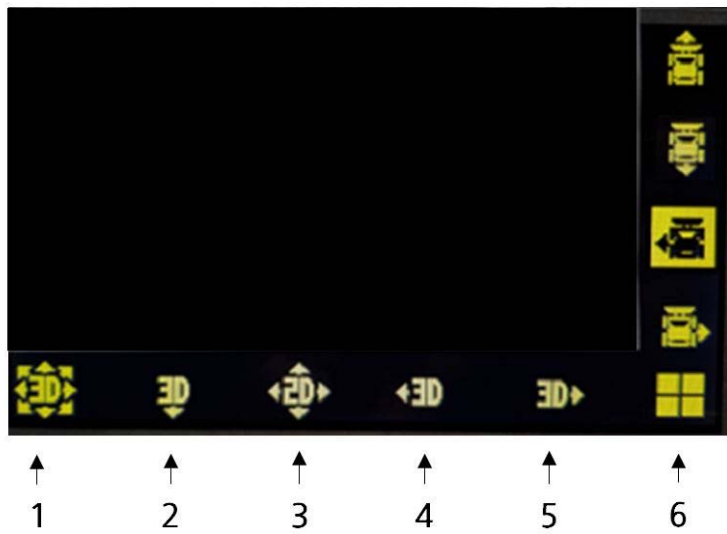

NO	Name
1	3D TOP
2	3D Rear
3	2D TOP
4	3D LEFT
5	3D RIGHT
6	4CH
7	RIGHT
8	LEFT
9	REAR
10	FRONT

UP & DOWN KEY ORDER

- UP : 1 → 2 → 3 → 4 → 5 → 6 → 7 → 8 → 9 → 10
- DOWN : 10 → 9 → 8 → 7 → 6 → 5 → 4 → 3 → 2 → 1

960A3CD74

### 3. STARTING AND STOPPING THE ENGINE

#### 1) CHECK INDICATOR LIGHTS

- (1) Check if the parking brake switch is ON.
- (2) Check if the gear selector lever is in neutral position.
- (3) Check if the pilot cut off switch is OFF.
- (4) Turn the key to the ON position, and check followings.

##### · Cluster

- ① If all the lamps light ON after sounding buzzer for 3 seconds.
  - ※ If the lamps do not light or the buzzer is not sounded, check disconnection of wire.
- ② Only below lamps will light ON and all the other light will be turn OFF after 3 seconds.
  - Charging warning lamp (1)
  - Engine oil pressure warning lamp (2)
  - Brake fail warning lamp (3)

##### · Monitor

- ① The buzzer sounds for 3 seconds with HYUNDAI logo on monitor.
  - ② If the ESL mode is set to the enable, enter the password to start engine.
  - ③ If the password has failed 5 times, please wait 30 minutes before re-attempting to enter the password.
- ※ Refer to page 3-30 for ESL system setting.

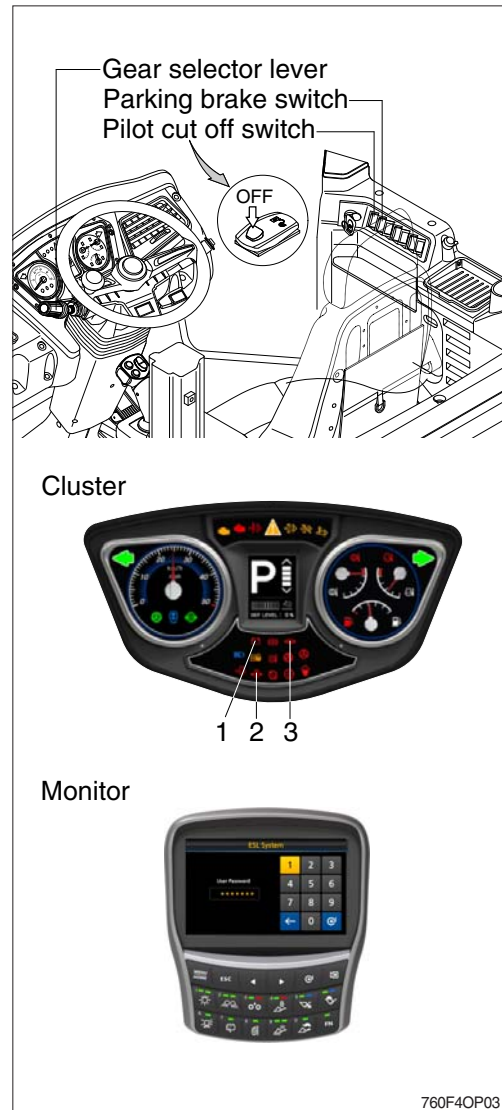

760F4OP03

### (7) Stopping engine

※ If the engine is abruptly stopped before it has cooled down, its service life may be shortened. Avoid sudden stop except an emergency.

※ When the engine is overheated, do not stop immediately. Run the engine at a mid range speed to allow it to cool down, then stop it.

- ① Check if the parking brake switch is ON.
- ② Check if the gear selector lever is in the neutral position.
- ③ Check if the pilot cut off switch is OFF.
- ④ Run the engine at low speed without operating the equipment for about 5 minutes.  
Turn the starting key to the OFF position and remove the key.

### (8) Checks after the engine stopped

- ① Check the leakage of oil and water, the work equipment and the exterior of the machine.
- ② Refill the fuel tank.
- ③ Remove any debris inside of the engine room and attached to the machine.

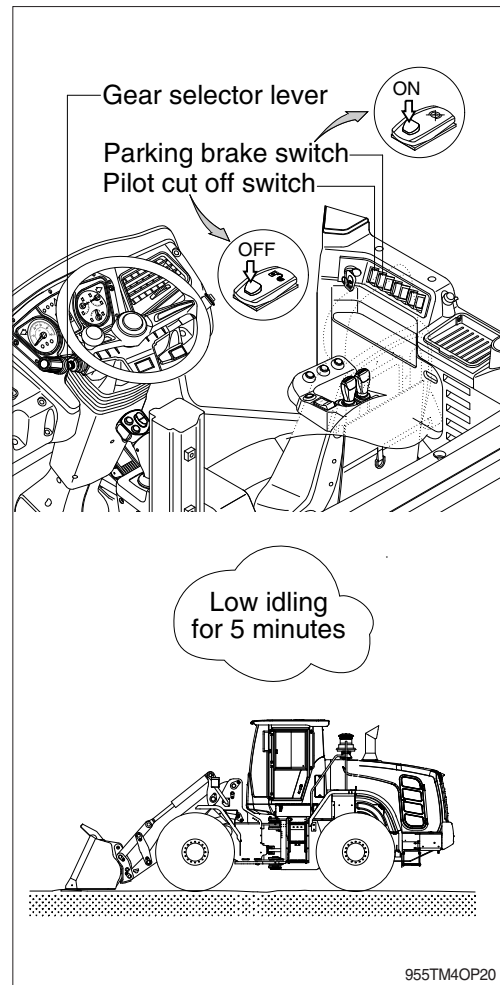

## 9. OPERATION IN THE SPECIAL WORK SITES

### 1) OPERATION THE MACHINE A COLD WEATHER

- (1) Use proper engine oil and fuel for the weather.
- (2) Fill the required amount of antifreeze in the coolant.
- (3) Refer to the starting engine in cold weather.  
Start the engine and extend the warming-up operation.
- (4) Be sure to open the heater cock when using the heater.
- (5) Always keep the battery completely charged.  
**※ Discharged batteries will freeze more easily than fully charged.**
- (6) Clean the machine and park on the wood plates.

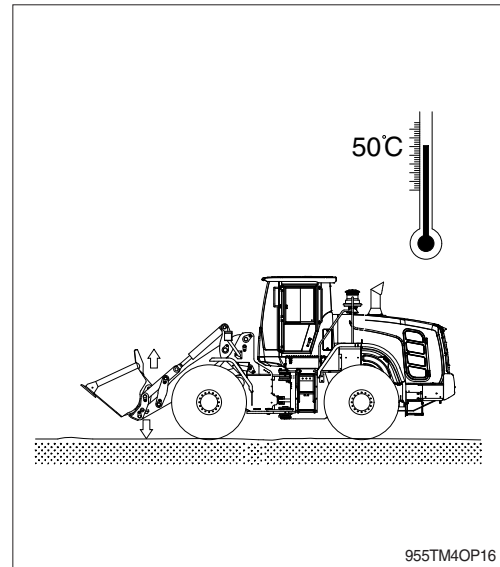

### 2) OPERATION IN SANDY OR DUSTY WORK SITES

- (1) Inspect air cleaner element frequently. Clean or replace element more frequently, if warning lamp comes ON and buzzer sounds simultaneously, regardless of inspection period.
- (2) Inspect radiator frequently, and keep cooling fins clean.
- (3) Prevent sand or dust from getting into fuel tank and hydraulic tank during refilling.
- (4) Prevent sand or dust from penetrating into hydraulic circuit by tightly closing breather cap of hydraulic oil tank. Replace hydraulic oil filter frequently.
- (5) Keep all lubricated part, such as pins and bushings, clean at all times.
- (6) If the air conditioner and heater filters clogged, the heating or cooling capacity will drop. Clean or replace the filters more frequently.

## 2. PREPARATION FOR TRANSPORTATION

- 1) When transporting the machine, observe the various road rules, road transportation vehicle laws and vehicle limit ordinances, etc.
- 2) Make sure the cooling system has proper anti-freeze if moving machine to a cold climate.
- 3) Select proper trailer after confirming the weight and dimension from the page 2-2~2-5.
- 4) Check the whole route such as the road width, the height of bridge and limit of weight and etc., which will be passed.
- 5) Get the permission from the related authority if necessary.

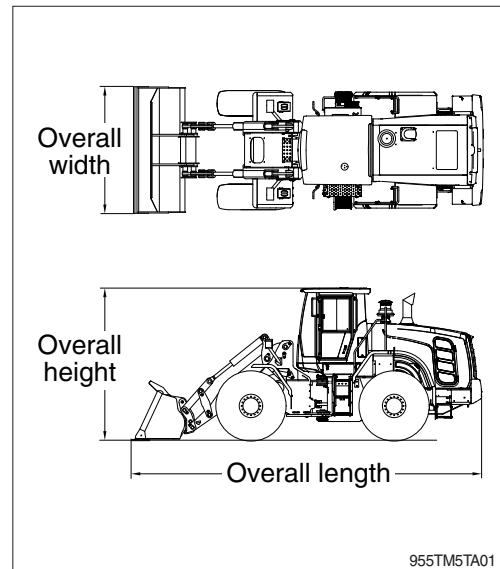

- 6) Prepare gangplank for safe loading referring to the below table and illustration.

A	B
1.0	3.65 ~ 3.85
1.1	4.00 ~ 4.25
1.2	4.35 ~ 4.60
1.3	4.75 ~ 5.00
1.4	5.10 ~ 5.40
1.5	5.50 ~ 5.75

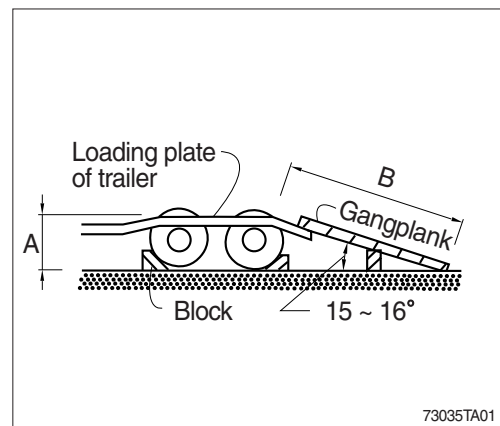

#### 4) RELIEVING THE PRESSURE IN THE HYDRAULIC SYSTEM

※ Spouting of oil can cause the accident when loosening the cap or hose right after the operating of the machine as the machine or oil is on the high pressure on the condition.

Be sure to relieve the pressure in the system before repairing hydraulic system.

- (1) Place the machine in parking position, and stop the engine.

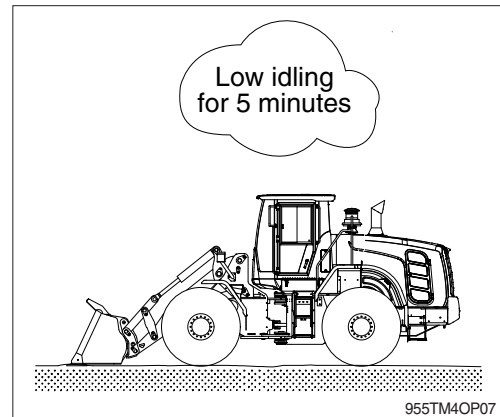

- (2) Rotate the cap nut counter-clockwise by hand and push the rod to release the air pressure.

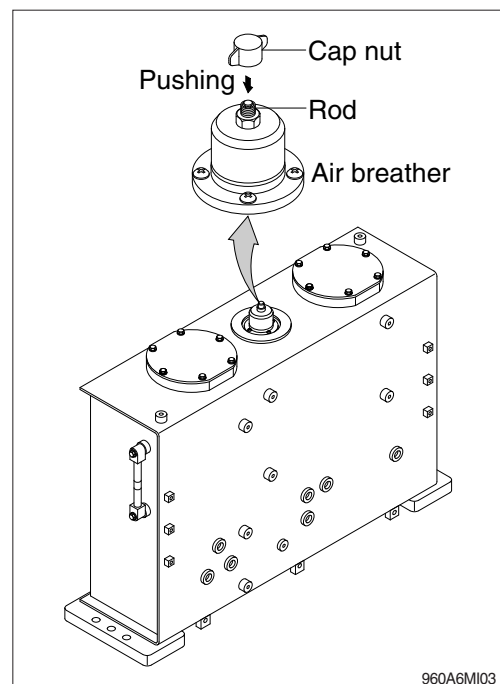

## 5. MAINTENANCE CHART

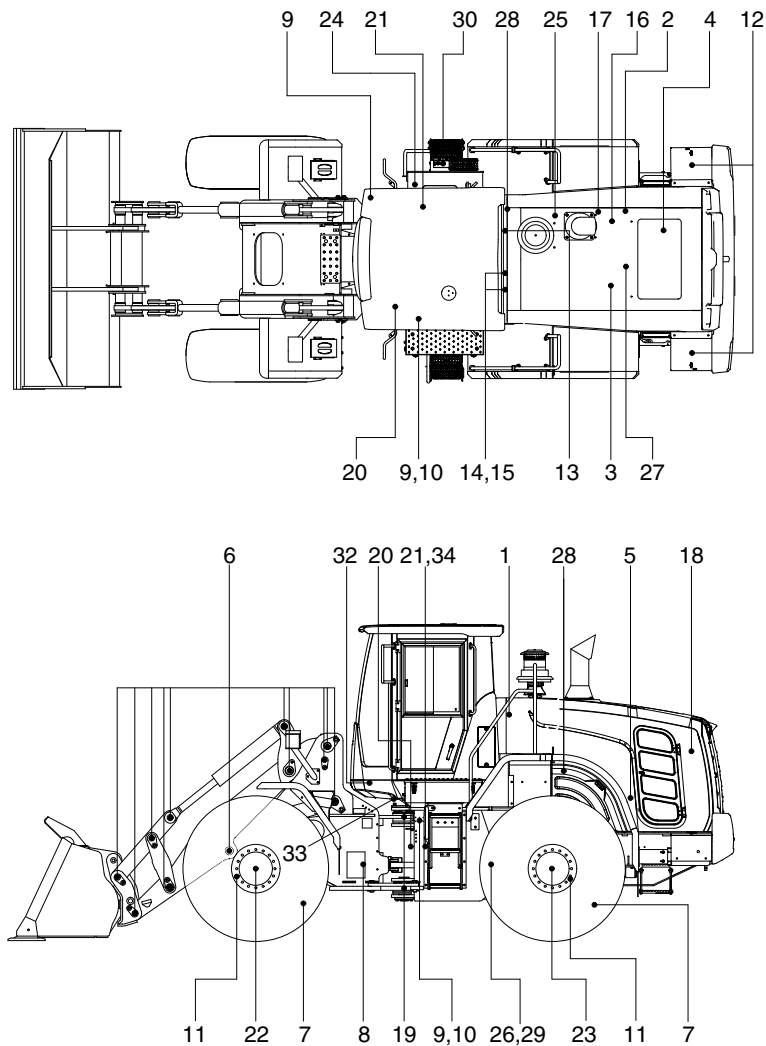

955TM6M110A

### Caution

1. Service intervals are based on the hour meter reading.
2. The number of each item shows the lubrication point on the machine.
3. Stop engine while filling oil, and use no open flames.
4. For other details, refer to the service manual.

- EO : Engine oil
- GO : Gear oil
- C : Coolant
- DEF : DEF/AdBlue®
- HO : Hydraulic oil
- PGL : Grease
- UTTO : Refer to page 6-9.

Service interval	No.	Description	Service action	Oil symbol	Capacity ℓ (U.S.gal)	Service points No.
10 Hours or daily	1	Hydraulic oil level	Check, Add	HO	110 (29.1)	1
	2	Engine oil level	Check, Add	EO	18 (4.8)	1
	4	Radiator coolant level	Check, Add	C	42 (11.1)	1
	5	Fan belt tension & damage	Check, Adjust	-	-	1
	17	Fuel pre-filter (water)	Drain	-	-	1
	29	DEF/AdBlue® tank	Check, Add	DEF	37.1 (9.8)	1
50 Hours or weekly	6	Attachment pins	Lubricate	PGL	-	13
	7	Tire (air)	Check, Add	-	-	4
	8	Drive shaft (flange bearing)	Lubricate	PGL	-	1
	9	Steering cylinder pin	Lubricate	PGL	-	4
	10	Rear axle pivot	Lubricate	PGL	-	2
	26	Drive shaft sleeve yoke	Lubricate	PGL	-	2
	28	Drive shaft journal bearing assy	Lubricate	PGL	-	5

## 9) FAN BELT TENSIONER

- (1) With the engine stopped, check the tensioner arm, pulley, and stops for cracks. If any cracks are found, the tensioner must be replaced.

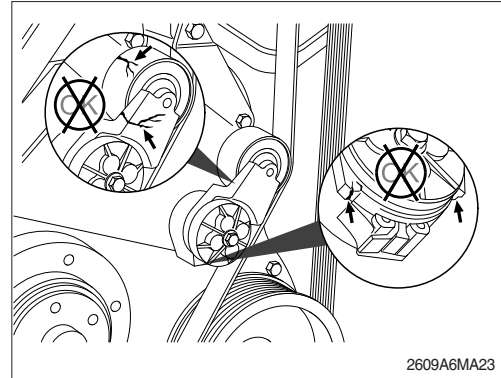

- (2) With the belt installed, verify that neither tensioner arm stop is in contact with the spring case stop.

After replacing the belt, if the tensioner arm stops are still in contact with the spring case stop, replace the tensioner.

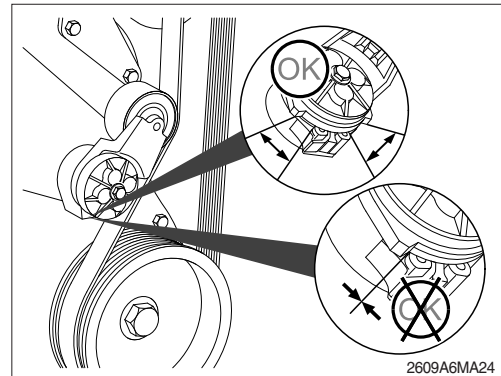

- (3) With the belt removed, verify that the tensioner arm stop is in contact with the spring case stop. If these two are not touching, the tensioner must be replaced.

※ **After replacing the belt, if the tensioner arm stop is still in contact with the spring case stop, the tensioner MUST be replaced.**

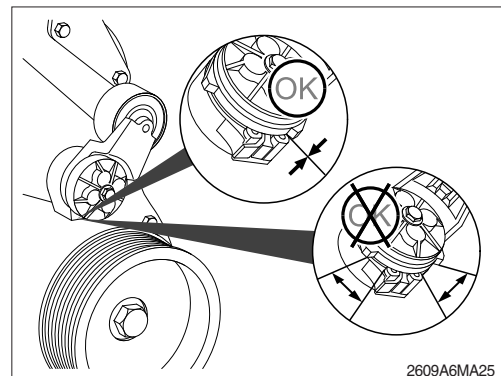

- (4) Check the location of the drive belt on the belt tensioner pulley. The belt should be centered on, or close to the middle of, the pulley. Misaligned belts, either too far forward or backward, can cause belt wear, belt roll-offs, or increase uneven tensioner bushing wear.

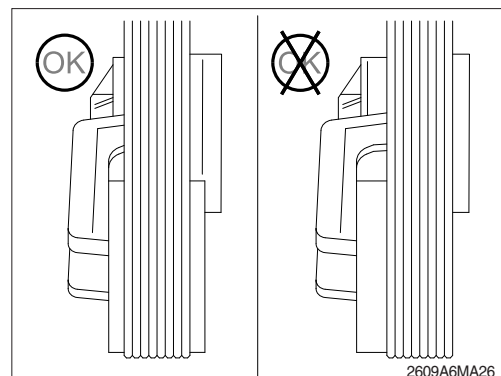

- (4) If both of the number 1 cylinder rocker levers are loose, proceed to the next step; If the number 1 cylinder rocker levers are not loose, rotate the crankshaft 360 degrees and proceed to the next step.

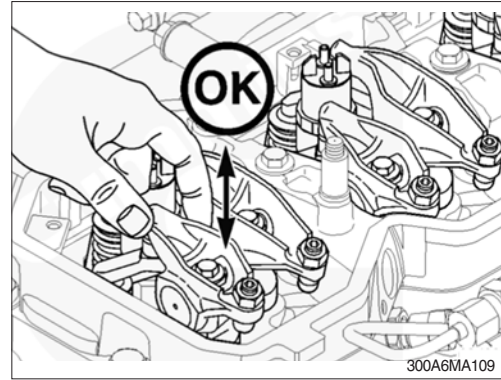

- (5) Make sure to check the engine dataplate for correct valve lash (overhead set) specifications. The engine dataplate is typically located on the engine rocker lever cover, but may also be located on the left side of the gear housing.

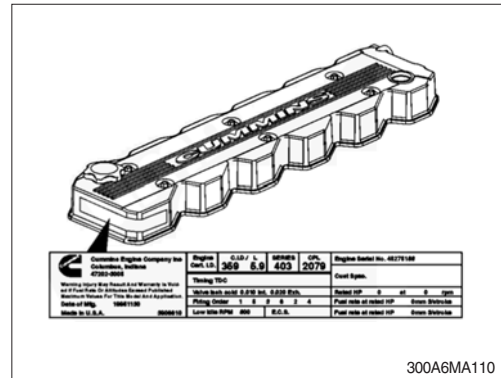

- (6) If the number 1 cylinder is at TDC and both rocker levers are loose, the valve lash (overhead set) can be checked on the following rocker levers:  
 (E = exhaust, I = Intake)  
 1I, 1E, 2I, 3E, 4I, and 5E.

Overhead set check limits

Item		mm	inch
Intake	Min	0.152	0.006
	Max	0.381	0.015
Exhaust	Min	0.381	0.015
	Max	0.762	0.030

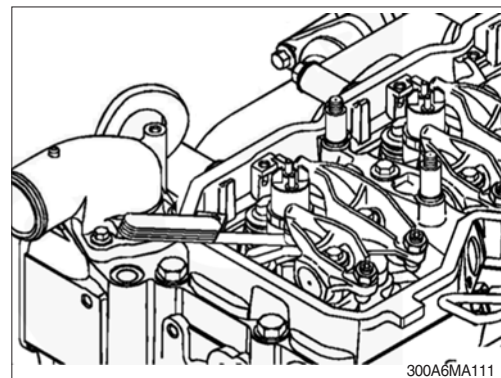

- (7) Checking the overhead setting is usually performed as part of a troubleshooting procedure, and resetting is not required during checks, as long as the lash measurements are within the specifications shown above.

### 35) CLEANING TRANSMISSION AIR BREATHER

- (1) Remove dust or debris around the air breather.
- (2) Remove the air breather and wash it with cleaning oil.

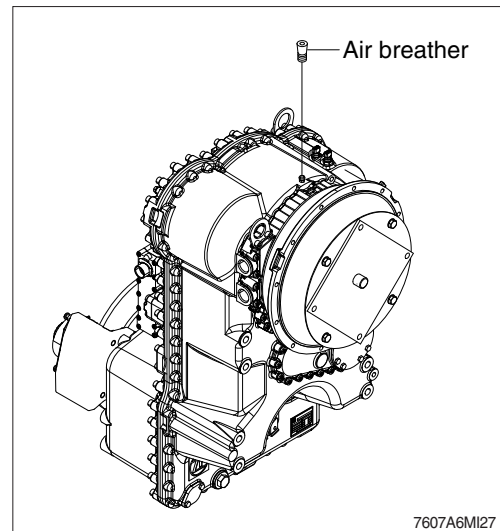

### 36) CHECK AND SUPPLYING AXLE OIL

- (1) Move the machine to flat ground.
- (2) Open the axle air breather to relieve internal air pressure.
- (3) Remove the plug and check the oil amount.  
If the oil level is at the hole of the plug, it is normal.

※ Provide fill & level plug with O-ring and install it.

▲ When checking the oil level, press the parking brake switch and fix front and rear frames using the safety lock bar.

▲ As the machine is hot after operation, wait until the temperature has dropped.  
Set the plug of planetary gear in parallel to the ground.

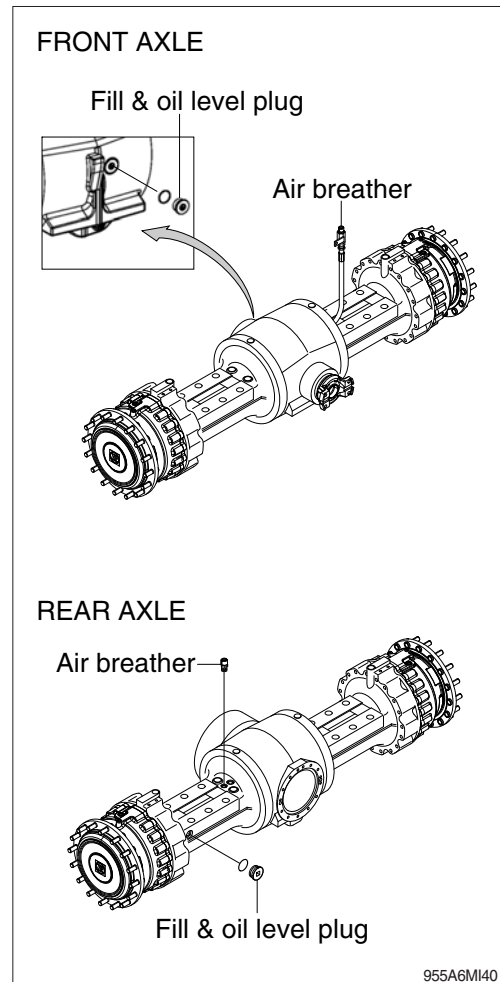

## 8. AIR CONDITIONER AND HEATER

### 1) CLEAN AND REPLACE OF INNER AND OUTER FILTER

※ Always stop the engine before servicing.

- (1) Open the air conditioner cover, loosen the wing bolt and remove the inner and outer filter.
- (2) Clean the filter using a pressurized air (below  $2 \text{ kgf/cm}^2$ , 28 psi).
- △ When using pressurized air, be sure to safety glasses.
- (3) Inspect the filter after cleaning. If it is damaged or badly contaminated, use a new filter.

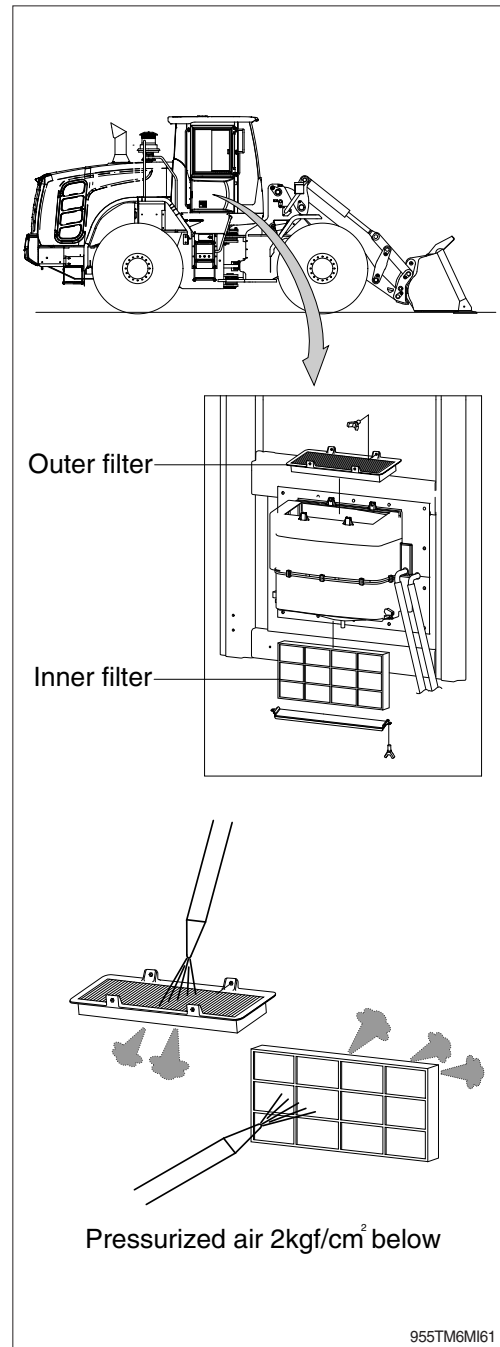

CLICK HERE TO **DOWNLOAD** THE COMPLETE MANUAL

- Thank you very much for reading the preview of the manual.
- You can download the complete manual from: [www.heydownloads.com](http://www.heydownloads.com) by clicking the link below



- Please note: If there is no response to CLICKING the link, please download this PDF first and then click on it.

CLICK HERE TO **DOWNLOAD** THE COMPLETE MANUAL