

CONTENTS

EC declaration of conformity	0-1	7. Efficient working method	4-15
Foreword	0-2	8. Adjustment of the work equipment	4-22
Emission-related components warranty (USA and CANADA only)	0-2-1	9. Operation in the special work sites	4-23
Before servicing this machine	0-3	10. Storage	4-25
Table to enter S/No and distribution	0-4	11. Exhaust system cleaning	4-27
EC regulation approved	0-5	12. Open the engine hood	4-28
Safety labels	0-6		
Machine data plate	0-16	5. TRANSPORTATION	
Guide (direction, S/No, symbol)	0-17	1. Road traveling	5-1
		2. Preparation for transportation	5-2
1. SAFETY HINTS		3. Loading the machine	5-3
1. California proposition 65	1-1	4. Fixing the machine	5-4
2. Safety rules	1-2	5. Loading and unloading by crane	5-6
		6. Towing the machine	5-7
2. SPECIFICATIONS		6. MAINTENANCE	
1. Major components	2-1	1. Instructions	6-1
2. Specifications	2-2	2. Tightening torque	6-5
3. Weight	2-6	3. Spec of fuel, coolant and lubricants	6-8
4. Specification for major components	2-7	4. Maintenance check list	6-10
		5. Maintenance chart	6-13
3. CONTROL DEVICES		6. Service instruction	6-15
1. Cab devices	3-1	7. Electrical system	6-50
2. Cluster	3-2	8. Air conditioner and heater	6-53
3. Monitors	3-13		
4. Switches	3-44	7. TROUBLESHOOTING GUIDE	
5. Control device	3-49	1. Engine	7-1
6. Air conditioner and heater	3-52	2. Electrical system	7-2
7. Others	3-55	3. Power train system	7-3
		4. Hydraulic system	7-4
4. OPERATION		8. OTHERS	
1. Suggestion for new machine	4-1	1. Quick coupler	8-1
2. Check before starting the engine	4-2		
3. Starting and stop the engine	4-3	INDEX	9-1
4. Warming-up operation	4-8		
5. Operation of the working device	4-9		
6. Traveling of the machine	4-10		

CLICK HERE TO **DOWNLOAD** THE COMPLETE MANUAL

- Thank you very much for reading the preview of the manual.
- You can download the complete manual from: www.heydownloads.com by clicking the link below



- Please note: If there is no response to CLICKING the link, please download this PDF first and then click on it.

CLICK HERE TO **DOWNLOAD** THE COMPLETE MANUAL

9) ENGINE START CAUTION (item 13)

This warning label is positioned on the right side window of the cab.

▲ Study the operator's manual before starting and operating machine.

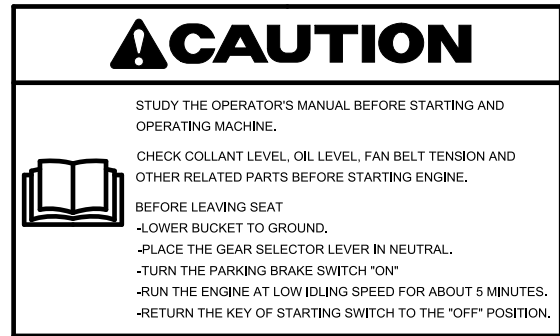

77070FW08

10) CONTROL IDEOGRAM (item 14)

This warning label is positioned on the right side window of the cab.

▲ Confirm the operation of control lever and working device before operating the machine.

※ Refer to the page 4-9 for details.

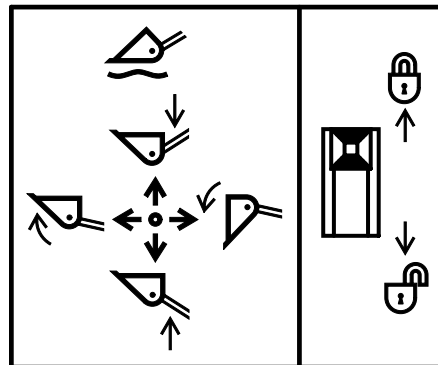

74090FW04

11) AIR CONDITIONER FILTER (item 15)

This warning label is positioned on the air-conditioner filter.

※ Periodic and proper inspection, cleaning and change of filter prolong air conditioner life time and maintain good performance.

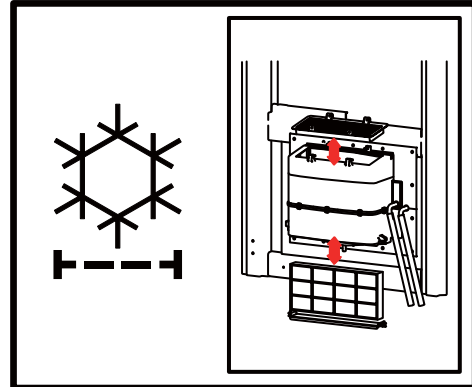

760F0FW10

12) ELECTRIC WELDING (item 16)

This warning label is positioned on the side of the battery box.

▲ Before carrying out any electric welding on this machine

- Pull the connectors out of all electronic control units.
- Connect the ground lead of the welding equipment as close to the welding point as possible.

※ Refer to the page 6-48 for details.

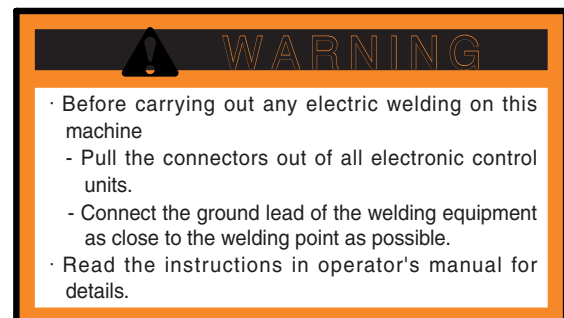

7803AFW20

2. SAFETY RULES

Safety Message

Intended Use

Machines should be operated in accordance with the procedure described in the Operator manual.

The products described in the Operator manual are designed and manufactured mainly for the following purposes:







- Loading work
- Leveling work

Do not operate the machine for any purpose other than those stated above or in areas where there are potential risks. Make sure that you comply strictly with the safety regulations at all times. Please contact Hyundai Construction Equipment Co., Ltd. or your dealer for more information.

It is strictly prohibited to operate or use the machine in any of the following cases:

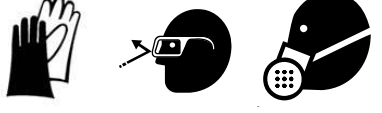
- Operation by an unskilled worker
- Lifting a worker up
- Transporting inflammable or dangerous materials
- Driving down or extracting piles with the bucket
- Towing damaged vehicles

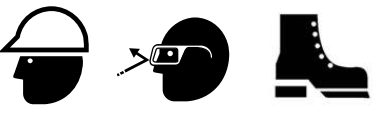
Personal protection gear for various situations

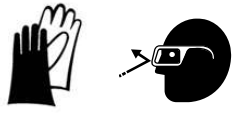
Situation	Symbol
Oil handling	
Battery handling	
Refrigerant handling	
Coolant handling	
Repair by welding	
Working in areas subject to airborne particles and falling objects	
Working in places with a high level of noise	
Handling machines damaged by fire or exposed to excessively high temperature	

WEAR PROTECTIVE CLOTHING

Wear close fitting clothing and safety equipment appropriate to the job.

- Do not wear loose clothing and accessories. Secure long hair. These items can snag on controls or on other parts of equipment.
- Do not wear oily clothes. They are highly flammable.
- Wear a hard hat, safety shoes, safety goggles, mask, leather gloves, earplugs and other protective equipment, as required.
- While working on machine, never use inadequate tools. They could break or slip, or they may not adequately perform intended.

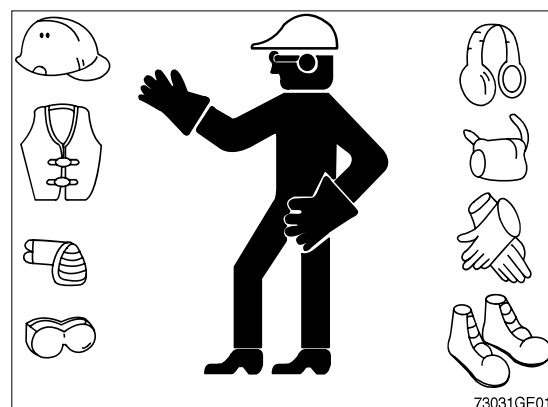

73031GE01

Operations to be avoided or prohibited

- Pay attention when operating the machine in an enclosed space as this may result in the risk of a buildup of hazardous gases.



- If the machine is operated in the vicinity of a high-voltage line, there is a risk of death or serious injury.
- Make sure you are fully aware of the height and working radius of the machine, and maintain the minimum safety distance.

Voltage	Minimum safety distance
6.6 kV	3 m (10 ft)
33.0 kV	4 m (13 ft)
66.0 kV	5 m (16 ft)
154.0 kV	8 m (26 ft)
275.0 kV	10 m (33 ft)

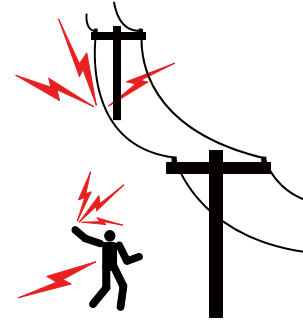

- In the event of contact with a high-voltage line, keep sitting on the operator's seat until the electric current has been shut down.
- Warn any workers on the ground in the vicinity of the machine not to make contact with the machine.
- If leaving the machine is unavoidable, jump down to a place free from any contact with the machine.
- Avoid operating the machine on soft ground, a slope or cliff as there is a risk that it may overturn. Pay special attention when it is raining as the rainfall may soften the ground.
- When operating or driving the machine underwater, check the floor conditions, depth of water and flow rate, and make sure that the top roller and axle housing are not immersed in water.
- Do not operate the machine under adverse weather conditions caused by overcast skies, snow and rainfall.
- Do not turn or travel the machine when the bucket is stuck in the ground.

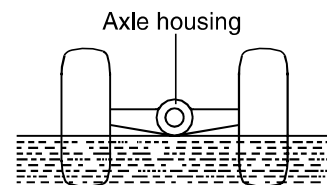
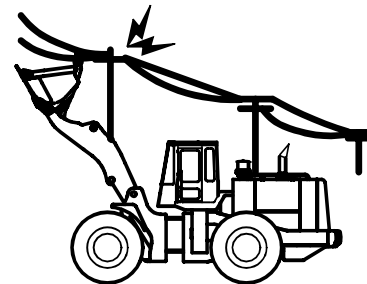

Visibility

Before you start the machine, perform a walk-around inspection in order to ensure that there are no hazards around the machine.

While the machine is in operation, constantly survey the area around the machine in order to identify potential hazards as hazards become visible around the machine.

Your machine may be equipped with visual aids. Some examples of visual aids are Closed Circuit Television(CCTV), AAVM(Advanced Around View Monitoring) and mirrors. Before operating the machine, ensure that the visual aids are in proper working condition and that the visual aids are clean.

If may not be possible to provide direct visibility on large machines to all areas around the machine, appropriate job site organization is required in order to minimize hazards that are caused by restricted visibility. Job site organization is a collection of rules and procedures that coordinates machines and people that work together in the same area.

Examples of job site organization include the following:

- Safety instructions
- Controlled patterns of machine movement and vehicle movement
- Workers that direct traffic to move when it is safe
- Restricted areas
- Operator training
- Warning symbols or warning signs on machines or on vehicles
- A system of communication
- Communication between workers and operators prior to approaching the machine

Modifications of the machine configuration by the user could result in a restriction of the machine visibility. In this case, a new risk assessment shall be performed according to ISO 5006:2017.

Restricted Visibility

The size and the configuration of this machine may result in areas that can not be seen when the operator is seated. The following illustration of visual map provides an approximate visual indication of areas of significant restricted visibility. This illustration indicates restricted visibility areas at ground level inside a radius of 12.00m (40 ft) from the operator on a machine only with the use of right side mirror and left side mirror installed. (without the use of optional visual aids.) This illustration provide areas of restricted visibility for distances outside a radius of 12.00m (40 ft).

This machine may be equipped with optional visual aids (CCTV or AAVM) that may provide visibility to some of the restricted visibility areas. For areas that are not covered by the optional visual aids, the job site organization must be utilized to minimize hazards of this restricted visibility.

3. WEIGHT

Item		kg	lb
Front frame assembly		1007	2220
Rear frame assembly		1326	2923
Front fender (LH & RH)		63	139
Counterweight	HL940A	313	690
	HL940A XT	506	1115
Cab assembly		917	2012
Engine assembly		520	1150
Transmission assembly		430	948
Drive shaft (front)		19	41
Drive shaft (center)		19	41
Drive shaft (rear)		14	30
Front axle (include differential)		750	1653
Rear axle (include differential)		760	1675
Tire (20.5 R25, ★L3)		238	525
Hydraulic tank assembly		142	313
Fuel tank assembly		291	641
Main pump assembly		35	77
Fan & brake pump assembly		17	37
Main control valve (2/3 spool)		44/50	97/110
Boom assembly	HL940A	717	1580
	HL940A XT	943	2078
Bell crank assembly		252	555
Quick coupler assembly		353	778
Bucket link		36	79
2.3 m ³ bucket, with bolt on cutting edge		1123	2475
2.1 m ³ bucket, with bolt on cutting edge		1070	2358
Boom cylinder assembly		81	178
Bucket cylinder assembly (HL940A/HL940A XT)		98/116	216/255
Steering cylinder assembly		17	37
Seat		70	154
Battery		30	66

(12) Check engine warning lamp

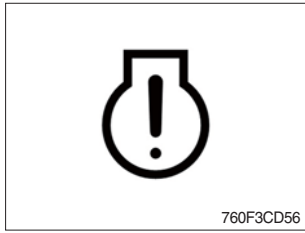

① This lamp lights ON and the buzzer sounds when the communication between MCU and engine ECM on the engine is abnormal, or if the cluster received specific fault code from engine ECM.

② Check the communication line between them.

If the communication line is OK, then check the fault codes on the monitor.

※ If you want to stop buzzer sound, just touch the  icon.

(13) Engine stop warning lamp

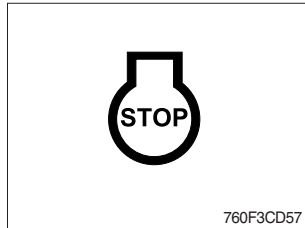

① This warning lamp pops up and the buzzer sounds when 30 minutes elapsed with empty condition of the DEF/AdBlue® tank, stop the engine immediately and check the DEF/AdBlue® tank.

② Fill the DEF/AdBlue® immediately in the DEF/AdBlue® tank.

※ Refer to page 3-10.

③ This lamp lights ON when the stationary exhaust system cleaning is not performed.

※ Refer to page 3-8.

※ Please contact your Hyundai service center or local dealer.

※ "Engine shutdown" cluster message up when the exhaust gas temperature reaches above 800 °C.

(14) Engine coolant low level warning lamp

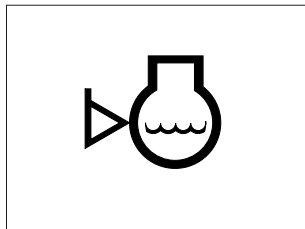

This warning lamp lights ON when the level of coolant is low. Fill the coolant immediately when the lamp is ON.

(15) Water in fuel warning lamp

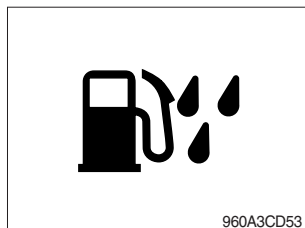

①

※ When this lamp lights ON, stop the machine and spill water out of the separator.

(3) Fault and maintenance warning

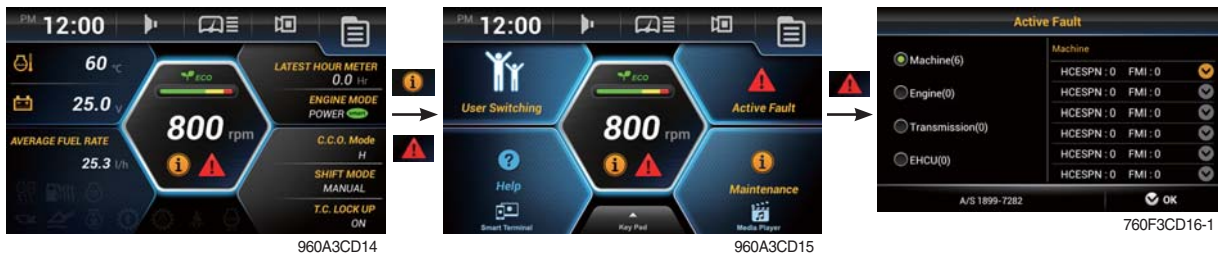

- ① If you touch the warning sign (red icon), move to the quick menu.
- ② You can check the fault message and move the maintenance screen by touching relevant area.



(4) Machine monitoring warning

- ① Warning sign (red icon) will be shown when the temperature of hydraulic oil, cooling water, transmission oil or battery voltage is not normal state.
- ② Case of warning sign

Icon	Description
	Above 106°C of hydraulic oil temperature
	Above 105°C of cooling water temperature
	Above 107°C of transmission oil temperature
	Below 24.5 voltage of battery (for 3 minutes)
	Above 100°C of axle oil temperature (option)



(5) Communication error

- ① MCU could not communicate with monitor over 10 seconds, error message will be show on the screen.



(6) Eco gauge

- ① This gauge indicates the fuel consumption rate and machine load status. So that operators can be careful with fuel economy.
- ② The fuel consumption rate or machine load is high, the segment is increased.
- ③ The color of Eco gauge indicates operation status.
 - White : Idle operation
 - Green : Economy operation
 - Yellow : Non-economy operation at a medium level.
 - Red : Non-economy operation at a high level.



· Boom pressure calibration

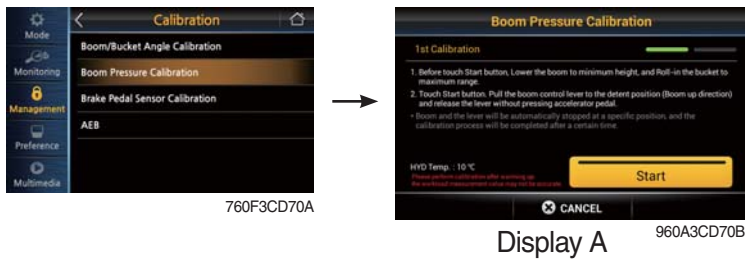

- Press START button after following the instruction.
- After a few minutes, "Calibration failed" or "Calibration completed" message will be shown. Press OK button then process be ended.

※ Using button

- Using  instead of NEXT, complete button.

· Boom pressure calibration

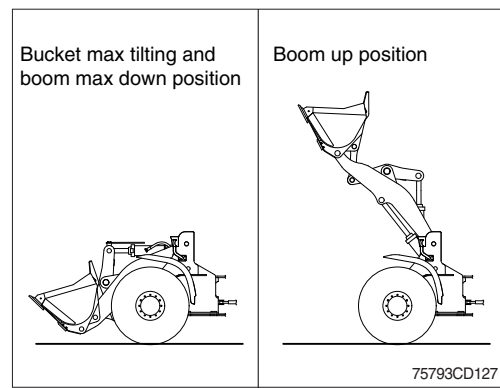

- It is used when bucket weight is changed or measured weight is inaccurate.
- The calibration must be carried out as follows :
 - ① Increase hydraulic temperature (about 40~60°C).
 - ② Select "Boom-pressure".
 - ③ Roll-in the bucket at maximum range and lower the boom at minimum height.
 - ④ Press START button.
 - ⑤ Raise boom to maximum position. Boom up must be finished before stepping advance in "display A".
 - ⑥ If it show "Calibration success" message in a moment, press complete button (or ).

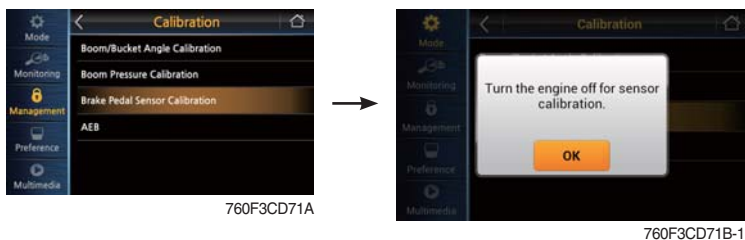

- ※ Raise hydraulic temperature enough when checking work load / boom pressure sensor calibration (recommendation : about 40 ~ 60°C).
- ※ Check if pressure sensor or angle sensor is in normal condition for accurate work load algorism or pressure sensor calibration [pressure sensors at boom cylinder head area and rod area, boom angle sensor (CD-80), bell crank angle sensor (CD-81)].
- ※ Sensor error message during pressure sensor calibration : sensor need to be checked.

· Brake pedal sensor calibration



- Turn the engine OFF and turn the starting switch ON position.
- Press OK button, then calibration will be started.
- When display "IP  " on main display, press slowly the brake pedal completely.
- Release the brake pedal when display "IP  " on main display.
- For cancel, press MENU/HOME switch.

- ※ When the brake pedal or sensor is replaced, **brake pedal sensor calibration must be performed.**

④ Display style/ Language

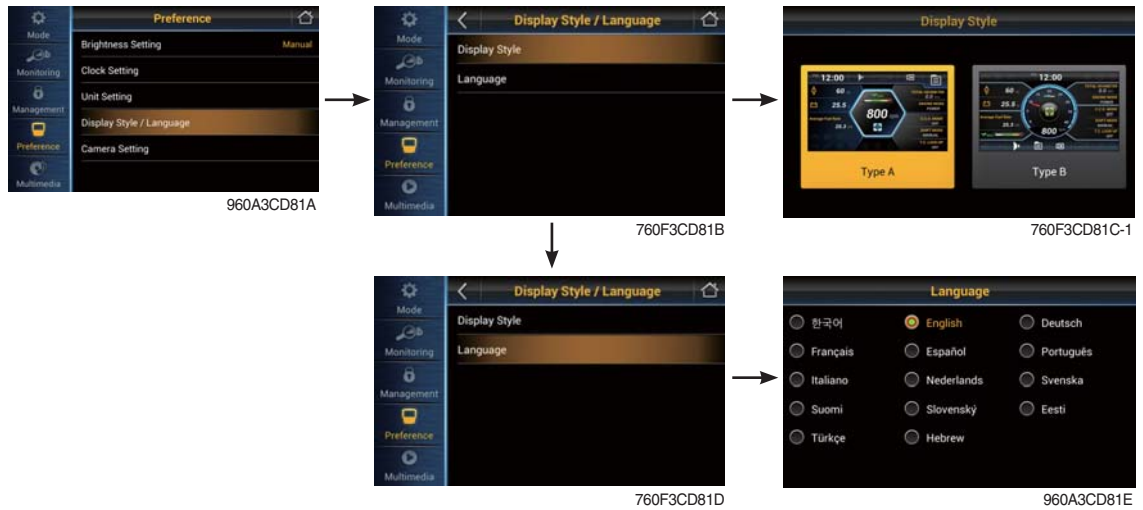

- Set the display type A or B.
- User can select preferable language and all display are changed the selected language.
- 14 multiple language available.

① Current weight in bucket/ Daily total weight

- This window displays the measured current weight information of the current bucket. Daily Total information accumulated up to today is displayed.
- Current / Daily Total changes the display status by clicking the tab
- The unit of weight depends on the monitor settings.

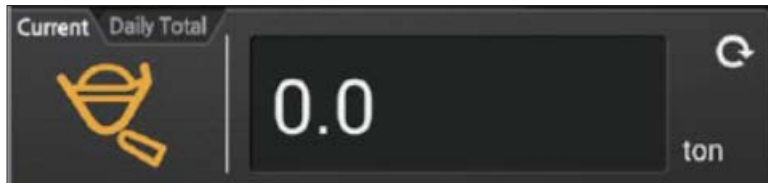

940A3CD10

② Select Button(Click gray icon) for status (Project status/Truck status)

- This button can select the cumulative weight of the project or the cumulative weight of the truck
- If you click on the gray icon, the icon will be changed Project →Truck or Truck →Project.



940A3CD11



940A3CD12

③ Target Weight

- It displays the set target weight value of Project or Truck. It can be set in the pop-up window.

④ Loaded weight (Progress bar or Total weight)

- It displays the set target weight value of Project or Truck. It can be set in the pop-up window.
- In the case of Truck status, percentage symbol (%) of the target value is displayed after the accumulated value. (Loaded weight / Target weight * 100)
- In the case of Truck status, it is displayed in the form of a Progress bar. The size of the entire bar is set to 120% of the target value, and the color of the bar is green when the target value is below and red when the target value is exceeded.

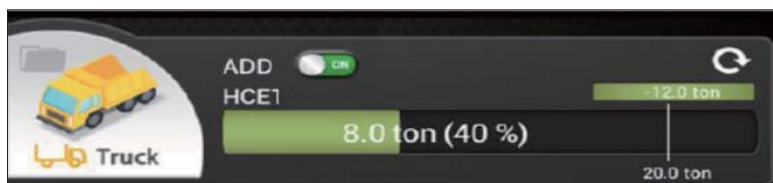

940A3CD13

9) KICK DOWN SWITCH

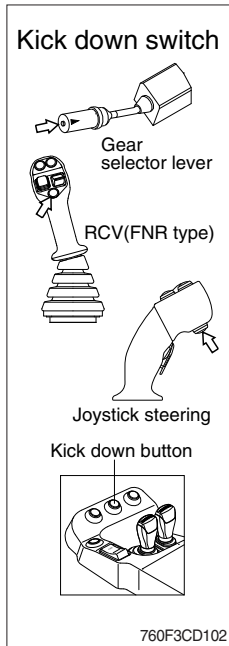

(1) Manual mode

It is effective 2nd speed to 1st speed only and recover to 2nd speed quickly when push the switch one more time.

(2) Automatic mode

① Mode 1 (down/up)

It shifts down quickly from current gear to one step lower speed by pushing the switch and recover to current speed quickly when push the switch one more time.

② Mode 2 (down)

It shifts down from current gear to one step lower speed when push the switch every time.

The kick down function is released in only 1st speed.

※ Refer to page 3-20 for the kick down mode.

※ The normal autoshift function continues after the kick down switch is released.

10) FNR SELECT BUTTON AND SWITCH

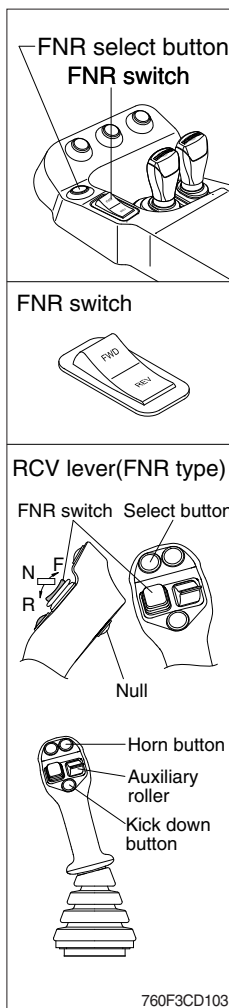

(1) These button and switch are used for forward and backward drive.

※ Gear range can be selected by gear selector lever.

(2) FNR select button

① If the select button is pressed, the indication lamp on the cluster will be ON and this FNR switch will start to operate.

※ When the engine is running, the machine is on standstill (0 speed), parking brake is released, gear selector lever is in the neutral position, you can use this function after pressing the select button.

(3) FNR switch

- F : Forward drive
- N : Neutral
- R : Reverse drive

① If the upper side (F, FWD) of this switch is pushed, the machine moves forward.

② If the down side (R, REV) of this switch is pushed, the machine moves backward.

③ This function is automatically released when the engine is stopped, parking brake is ON or gear selector lever is out of neutral.

(4) Auxiliary roller : If the machine is equipped with auxiliary hydraulics, this roller is used for the attachments.

CLICK HERE TO **DOWNLOAD** THE COMPLETE MANUAL

- Thank you very much for reading the preview of the manual.
- You can download the complete manual from: www.heydownloads.com by clicking the link below



- Please note: If there is no response to CLICKING the link, please download this PDF first and then click on it.

CLICK HERE TO **DOWNLOAD** THE COMPLETE MANUAL

2) SEAT

The seat is adjustable to fit the contours of the operator's body. It will reduce operator fatigue due to long work hours and enhance work efficiency.

- ▲ Always check the condition of the seat belt and mounting hardware before operating the machine.
- ▲ Fail to wear a seat belt during the machine operation may result in serious injury or death in the event of an accident or machine overturn.

(1) Weight and height adjustment

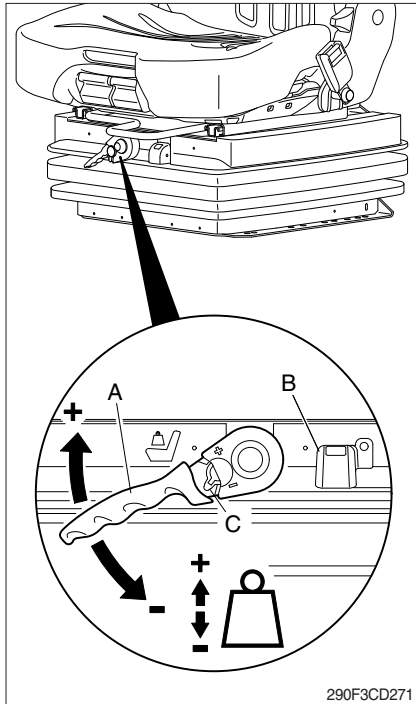

With socket wrench (A) :

- ① The seat has to be adjusted for the operator's weight and height by tilting the handle (+) up or down (-) with the operator not sitting on the seat.
- ② The rotational direction is reversed by toggling the ratchet with the switch (C).
- ③ The operator's weight and the seat height are adjusted correctly when the green marking is completely visible in the indicator window (B) for weight and height.
- ④ The height can be adjusted individually as long as the green marking is visible.

Weight adjustment (AIR SUSPENSION, OPT)

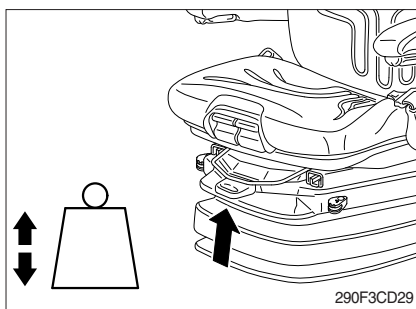

- ① The seat should be adjusted for the operator's weight by briefly pulling the actuator lever of the automatic weight and height adjuster (arrow) with the machine at a standstill and the operator's sitting on the seat.
The operator must sit absolutely still during adjustment.
- ※ Before adjusting the weight, adjust shock absorbers to the position "soft".
 - ※ To prevent damage to the health, the setting for the operator's weight must be checked and adjusted before the machine is operated.

(2) Menu Selection



- ① This button can adjust the sound effect and other things.
Each time you press this button (2), LCD displays as follows :

BAS → TREB → BAL L=R → FAD F=R → EQ → LOUD ON →
BEEP 2ND

On each setting, the level can be controlled by turning TUNE knob (2).
When the last adjustment is made, after 5 seconds, the display will
automatically return to the previous display mode.

② Bass control

To adjust the bass tone level, first select the bass mode by pressing
SEL button (2) repeatedly until BASS appears on the display panel.
Then turn knob (2) right or left within 5 seconds to adjust the bass
level as desired. The bass level will be shown on the display panel
from a minimum of BASS-7 to a maximum of BASS+7.

③ Treble control

To adjust the treble tone level, first select the treble mode by
pressing SEL button (2) repeatedly until TREB appears on the
display panel. Then turn knob (2) right or left within 5 seconds to
adjust the treble level as desired. The treble level will be shown on
the display panel from a minimum of TREB -7 to a maximum of
TREB +7.

④ Balance control

To adjust the left-right speaker balance, first select the balance
mode by pressing SEL button (2) repeatedly until BAL indication
appears on the display panel. Then turn knob (2) right or left within 5
seconds to adjust the balance as desired. The balance position will
be shown by the bars on the display panel from BAL 10R (full right)
to BAL 10L (full left).

⑤ Fader control

To adjust the front-rear speaker balance, first select the fader mode
by pressing SEL button (2) repeatedly until FADER indication
appears on the display panel. Then turn knob (2) right or left within 5
seconds to adjust the front-rear speaker level as desired. The fader
position will be shown by the bars on the display panel from FAD
10F (full front) to FAD 10R (full rear).

⑥ EQ control

You can select an equalizer curve for 4 music types (CLASSIC,
POP, ROCK, JAZZ). Press button (2) until EQ is displayed, then turn
knob (2) right or left to select the desired equalizer curve. Each time
you turn the knob, LCD displays as follows :

EQ OFF → CLASSIC → POP → ROCK → JAZZ

- ※ When the EQ mode is activated, the BASS and TREBLE modes
are not displayed.

6) Audio transfer between the audio unit and phone

The audio transfer function is for switching the call from the audio unit to the cellular phone for private conversation.



(1) Press CALL button (4) briefly during conversation, it appears CALL TRANS on the display. To switch back to the audio unit, press button (4) briefly during private conversation, then it appears CALL TRANS on the display again.

※ **This function will be a cause of disconnection of bluetooth link in some nokia phones, but you do not worry just press button (4) during private conversation, then switch back to the audio unit automatically.**

※ **The quality of calling between cellular phone and audio unit is better than calling between one audio unit and another one.**

7) Last call number dialing



(1) Press CALL button (4) briefly, it appears CALL TO, then simply press CALL button once again, it would make the last call with phone number display on LCD.

If Reject call is activated in your phone, then your cellular phone does not support Reject Call function.

※ **If you are using SAMSUNG phone, then you may need to press once more send button. First press button shows phone contact list in your phone, then second press make the last call.**

8) To make a call by cellular phone

The audio transfer function is for switching the call from the audio unit to the cellular phone for private conversation.

(1) The audio unit activated automatically when you make a call by cellular phone.

(2) When you make a call processing by cellular phone, it shows CALLING on the display.

(3) When you receive a call, the phone number ***** appears on the display.

(8) Parking guide line adjust

❖ How to Enter

 → LONG KEY (2sec)	<table border="1"> <thead> <tr> <th colspan="2">CAMERA1 SETTING</th> <th colspan="2">CAMERA2 SETTING</th> </tr> </thead> <tbody> <tr> <td>▪ MIRROR</td> <td>: OFF</td> <td>▪ MIRROR</td> <td>: OFF</td> </tr> <tr> <td>▪ UPSIDE DOWN</td> <td>: OFF</td> <td>▪ UPSIDE DOWN</td> <td>: OFF</td> </tr> <tr> <td>▪ TRIGGER ENABLE</td> <td>: ON</td> <td>▪ TRIGGER ENABLE</td> <td>: ON</td> </tr> <tr> <td>▪ TRIGGER SUSTAIN</td> <td>: 02sec</td> <td>▪ TRIGGER SUSTAIN</td> <td>: 02sec</td> </tr> <tr> <td>▪ MARKER DISPLAY</td> <td>: OFF</td> <td>▪ MARKER DISPLAY</td> <td>: OFF</td> </tr> <tr> <td>▪ MARKER TYPE</td> <td>: TypeA</td> <td>▪ MARKER TYPE</td> <td>: TypeA</td> </tr> <tr> <td>▪ MARKER POSITION</td> <td>: Enter</td> <td>▪ MARKER POSITION</td> <td>: Enter</td> </tr> </tbody> </table>	CAMERA1 SETTING		CAMERA2 SETTING		▪ MIRROR	: OFF	▪ MIRROR	: OFF	▪ UPSIDE DOWN	: OFF	▪ UPSIDE DOWN	: OFF	▪ TRIGGER ENABLE	: ON	▪ TRIGGER ENABLE	: ON	▪ TRIGGER SUSTAIN	: 02sec	▪ TRIGGER SUSTAIN	: 02sec	▪ MARKER DISPLAY	: OFF	▪ MARKER DISPLAY	: OFF	▪ MARKER TYPE	: TypeA	▪ MARKER TYPE	: TypeA	▪ MARKER POSITION	: Enter	▪ MARKER POSITION	: Enter
CAMERA1 SETTING		CAMERA2 SETTING																															
▪ MIRROR	: OFF	▪ MIRROR	: OFF																														
▪ UPSIDE DOWN	: OFF	▪ UPSIDE DOWN	: OFF																														
▪ TRIGGER ENABLE	: ON	▪ TRIGGER ENABLE	: ON																														
▪ TRIGGER SUSTAIN	: 02sec	▪ TRIGGER SUSTAIN	: 02sec																														
▪ MARKER DISPLAY	: OFF	▪ MARKER DISPLAY	: OFF																														
▪ MARKER TYPE	: TypeA	▪ MARKER TYPE	: TypeA																														
▪ MARKER POSITION	: Enter	▪ MARKER POSITION	: Enter																														
Menu BUTTON LONG KEY Enter	CAMERA 1, 2 SETTING [MARKER POSITION] SELECT and Enter																																

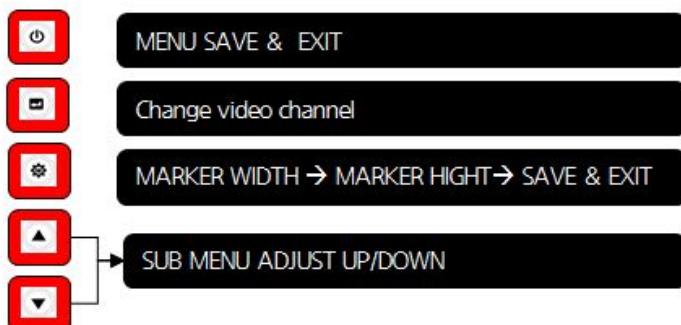

■ MARKER WIDTH		[60]
■ MARKER HIGHT		[0]

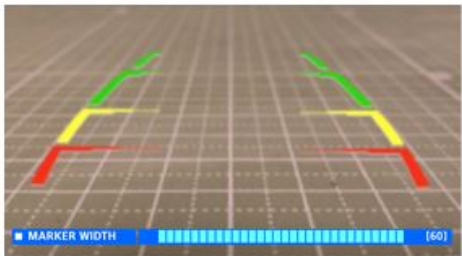
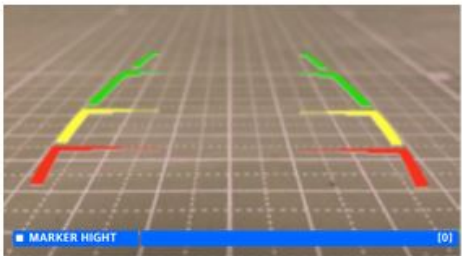
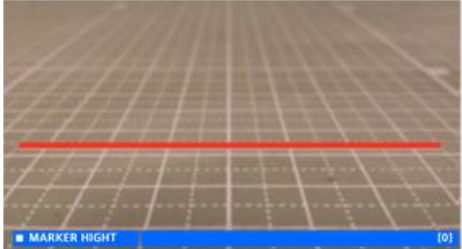
TYPE A		
TYPE B		
<ol style="list-style-type: none"> To set the parking line, [MARKER DISPLAY: ALWAYS or TRIGGER] must be set in Camera 1 or Camera 2 setting. In other modes, the parking line can not be set. [MARKER DISPLAY : OFF] <ol style="list-style-type: none"> The parking line positioning menu should not be selected. Do not enter LONG KEY with the menu button. 		

4) INSPECTION AFTER ENGINE START

Inspect and confirm the following after engine starts.

- (1) Is the level gauge of hydraulic oil tank in the normal level?
 - (2) Are there leakages of oil or water?
 - (3) Are all the warning lamps (1-19) OFF?
 - (4) Check the following after warming up operation.
 - ① Is the indicator of water temperature gauge (14) in the operating range?
 - ② Is the indicator of transmission oil temperature gauge (13) in the operating range?
 - ③ Is the engine sound and the color of exhaust gas normal?
 - ④ Are the sound and vibration normal?
- ※ **Do not increase engine speed quickly after starting, it can make damage engine or turbocharger.**
- ※ **If there are problems in the control panel, stop the engine immediately and correct problem as required.**

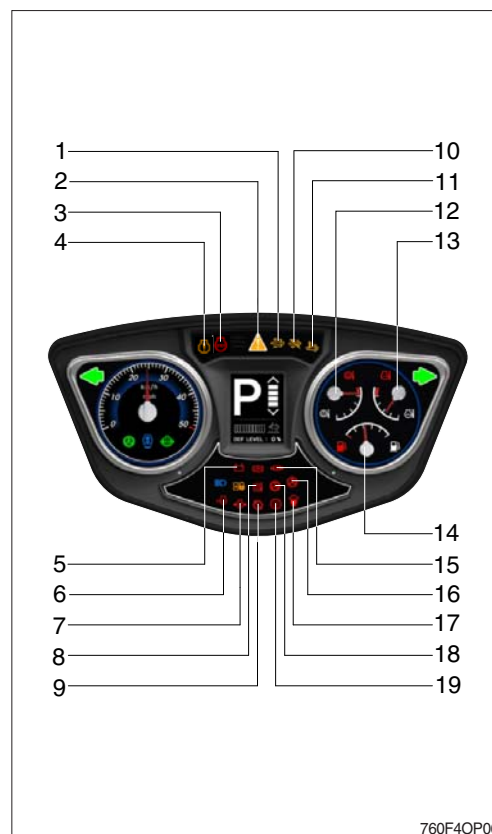

760F4OP06

5) TRANSMISSION COLD STARTING

- (1) At an oil temperature in the shifting circuit -12°C, the transmission must be warmed-up for some minutes.
- (2) This must be carried out in neutral with an increased engine speed.
- (3) Until this oil temperature is reached, the electronics remains in neutral, and the symbol of the cold start phase will be indicated on the display.
 - Indication on the display : **
- (4) After the indication on the display is extinguished, the full driving program can be utilized out of NEUTRAL.

※ Transmission warning



760F4OP15

Symbol	Meaning	Remarks
LF, LR	Limp home gear	-
**	Oil temperature too low, no gear available	Warm up engine/transmission
WS	Warning sump temperature	Alternate between WS and actual gear / direction while driving, in neutral only displayed WS if no fault is detected ※ Cool down transmission
WT	Warning torque converter temperature	Alternate between WS and actual gear / direction while driving, in neutral only displayed WS if no fault is detected ※ Cool down transmission

2) EXCAVATION WORK

(1) Shovel work

As the machine loads on the bucket with traveling, tires may start to slip because of heavy load. Then lift the bucket slightly to reduce load.

- ① Keep the bucket shovel parallel to the ground (If the bucket is pushed in a non-horizontal position, power may be reduced, and the bucket cannot dig deeply into the heap of soil).

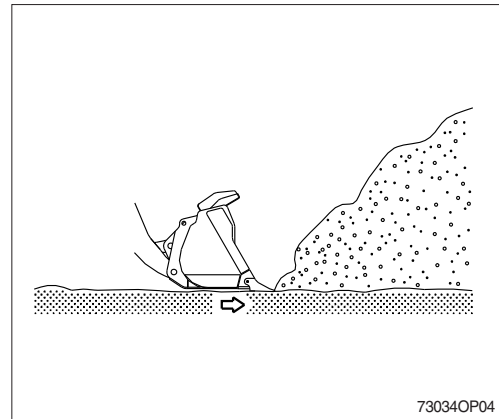

- ② When the bucket is sufficiently deep into the pile, advance the machine with the control lever pulled down. And by placing the control lever in the bucket roll-back position, fill the bucket with soil.

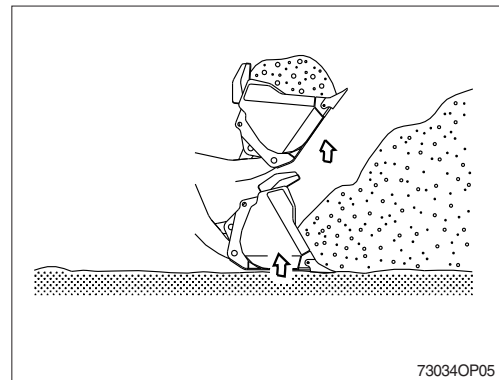

- ③ When it is difficult to dig into the soil, move the bucket control lever forward and backward to move the bucket teeth up and down.

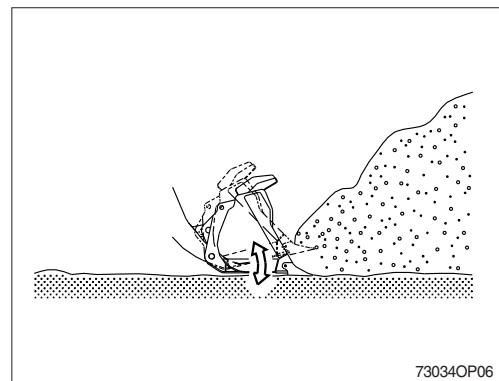

- ※ If the machine operates with its front tires lifted, its driving force will deteriorate and excessive force will be applied to the rear tires. Avoid operating in that posture.

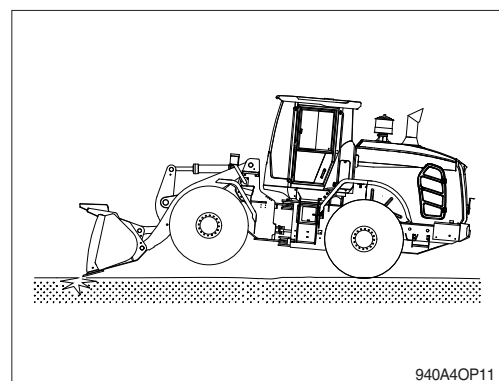

6) DURING STORAGE

Start engine and move the machine and working equipment once a month and apply lubrication to each part.

- ※ Check the level of engine oil and coolant and fill if required when starting engine.
- ※ Clean the anticorrosive on the piston rod of cylinder.
- ※ Operate the machine such as traveling, turning, and work equipment operation to make sure enough lubrication of all functional components.

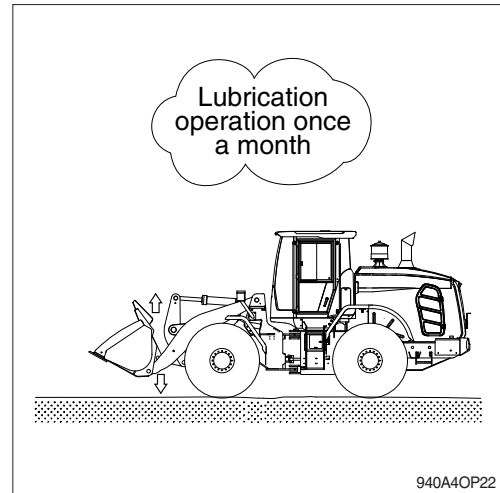

※ BATTERY

- ① Once a month, start the engine for 15 minutes (or use a charger) to charge the battery.
- ② Every 2 months, check the battery voltage and keep battery voltage over 25.08V.
- ③ If the machine stock period is over 6 months, disconnect the battery negative (-) terminal.

5. LOADING AND UNLOADING BY CRANE

- 1) Check the weight, length, width and height of the machine referring to chapter 2, Specification when you are going to hoist the machine.
 - 2) Use long wire rope and stay to keep the distance with the machine as it should avoid to touch with the machine.
 - 3) Put a rubber plate contact with wire rope and machine to prevent damage.
 - 4) Place crane on the proper place.
 - 5) Install the wire rope and stay like the illustration.
- ▲ **Make sure wire rope is proper size.**
 - ▲ **Place the safety lock bar and pilot cut off switch to the OFF position to prevent the machine moving when hoisting the machine.**
 - ▲ **The wrong hoisting method or installation of wire rope can cause damage to the machine.**
 - ▲ **Do not load abruptly.**
 - ▲ **Keep area clear of personnel.**
 - ▲ **Attach two wire ropes to the rear of the machine. Attach two wire ropes to the front of the machine. Connect the four wire ropes.**

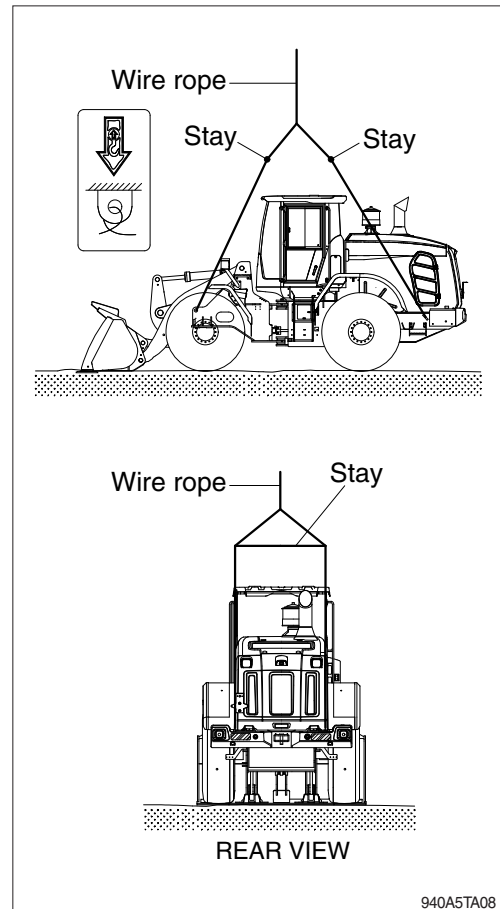

5) TIGHTENING TORQUE OF MAJOR COMPONENT

No.	Descriptions	Bolt size	Torque		
			kgf · m	lbf · ft	
1	Engine	Engine mounting bolt, nut (rubber, 2EA)	M20×2.5	57.9 ± 8.7	419 ± 63
2		Engine mounting bolt (bracket, 8EA)	M12×1.75	11.7 ± 1.8	84.6 ± 13
3		Engine mounting bolt (T/C plate-adaptor, 4EA)	M10×1.5	6.9 ± 1.4	49.9 ± 10.1
4		Engine mounting stud bolt, nut (flywheel, 10EA)	M10×1.5	6.8 ± 1.0	49.2 ± 7.2
5		Engine mounting stud bolt (flywheel, 2EA)	M10×1.5	4.6 ± 0.9	33.3 ± 6.5
6		Fan motor mounting bolt	M12×1.75	12.8 ± 3.0	92.6 ± 21.7
7		Radiator mounting bolt	M16×2.0	29.7 ± 5.9	215 ± 42.7
8		Fuel tank mounting bolt	M16×2.0	29.7 ± 4.5	215 ± 32.5
9	Hydraulic system	Main pump housing mounting bolt	M16×2.0	29.7 ± 4.5	215 ± 32.5
10		Fan & brake pump housing mounting bolt	M10×1.5	6.9 ± 1.4	50 ± 10.1
11		Main control valve mounting bolt	M10×1.5	6.9 ± 1.4	50 ± 10.1
12		Steering unit mounting bolt	M10×1.5	6.9 ± 1.4	50 ± 10.1
13		Brake valve mounting bolt	M8×1.25	2.5 ± 0.5	18.1 ± 3.6
14		Cut-off valve mounting bolt	M8×1.25	2.5 ± 0.5	18.1 ± 3.6
15		Remote control lever mounting bolt	M6×1.0	1.1 ± 0.2	8.0 ± 1.4
16		Safety valve	M10×1.5	6.9 ± 1.4	50 ± 10.1
17		Hydraulic oil tank mounting bolt	M16×2.0	29.7 ± 4.5	215 ± 32.5
18	Power train system	Transmission mounting bolt, nut (rubber, 2EA)	M24×3.0	100 ± 15	723 ± 108
19		Transmission mounting bolt (bracket, 6EA)	M20×2.5	56.1 ± 8.4	406 ± 60.8
20		Front axle mounting bolt, nut	M27×2.0	135 ± 20.2	976 ± 146
21		Rear axle support mounting bolt, nut	M27×2.0	135 ± 15	976 ± 108
22		Tire mounting nut	M22×1.5	79 ± 11.9	571 ± 86.1
23		Drive shaft joint mounting bolt	3/8-24UNF	6.0 ± 0.8	43.4 ± 5.8
24	Others	Counterweight mounting bolt (4EA)	M30×3.5	199 ± 30	1439 ± 216
25		Operator's seat mounting bolt	M8×1.25	3.4 ± 0.8	24.6 ± 5.0
26		ROPS Cab mounting bolt (4EA)	M20×2.5	58 ± 8.7	419 ± 63
		ROPS Cab mounting nut (4EA)	M16×2.0	20.5 ± 4.7	148 ± 34

- (10) Operate the engine at low idle and inspect for leaks at the filter and the drain plug.
Shut the engine off and check oil level with dipstick. Allow 15 minutes for oil to drain down before checking.

※ Do not overfill the engine with oil.

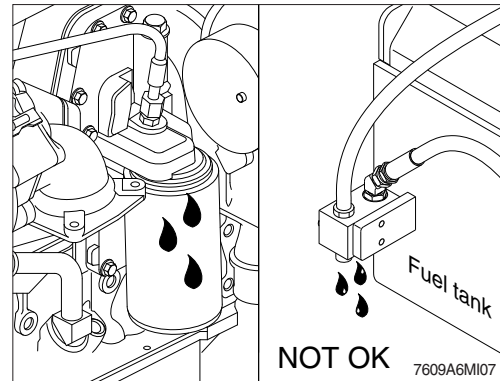

3) CHECK COOLANT LEVEL

- (1) Check the engine fault code on the monitor.
- (2) If you following fault codes exist, check the coolant level.
- SPN : 111, FMI : 18
 - Coolant level is low.
 - SPN : 111, FMI : 1
 - Coolant level is the most severely low.
- (3) Add the mixture of antifreeze and water after removing the cap of the surge tank if coolant is not sufficient.

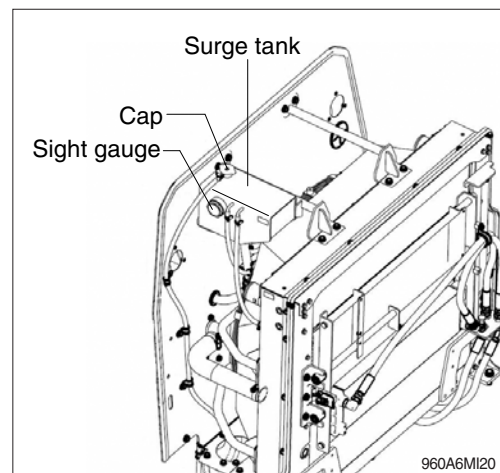

- (4) Replace gasket of surge tank cap when it is damaged.

▲ Do not remove the surge tank cap from a hot engine. Wait until the coolant temperature is below 50°C (120°F) before removing the cap. Heated coolant spray or steam can cause personal injury.

※ Do not add cold coolant to a hot engine ; engine castings can be damaged. Allow the engine to cool to below 50°C (120°F) before adding coolant.

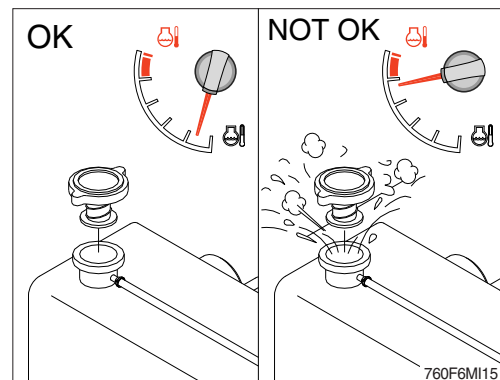

16) LEAKAGE OF FUEL

- ▲ Be careful and clean the fuel hose, injection pump, fuel filter and other connections as the leakage from these part can cause fire.

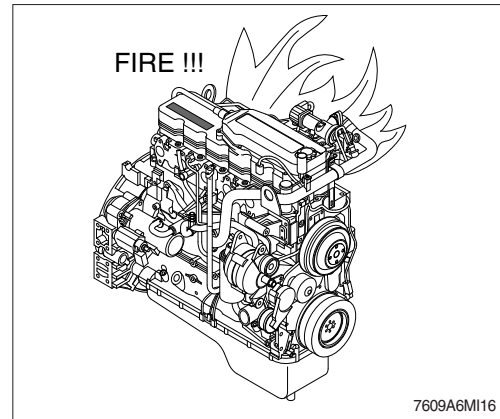

17) DEF/AdBlue® TANK

- (1) The DEF/AdBlue® tank level must be checked daily with DEF/AdBlue® level on LCD. Refer to the page 3-12.
- ※ Make sure that the filler filter in cap is clean. If it is dirty, clean the filler filter with clean water and refit it.

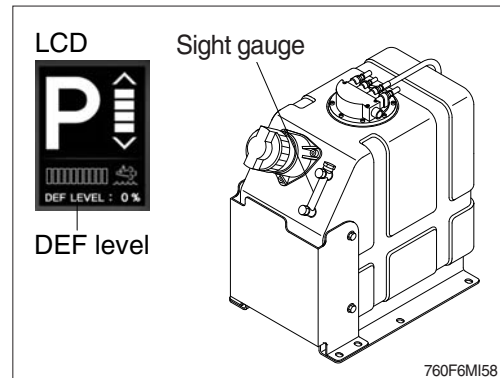

- (2) If the DEF/AdBlue® level is found to below, DEF/AdBlue® must be added.
- (3) When fill the tank with DEF/AdBlue®, check the sight gauge and don't fill up "F" level line to prevent overflow.

- ▲ It is unlawful to tamper with or remove any component of the aftertreatment system. It is also unlawful to use a catalyst solution that does not meet the specifications provided or the operate the machine with no catalytic solution.
- ※ Be careful to entering dust, sand or other contamination substance when you refill the DEF/AdBlue® into the tank. Otherwise, fatal problem such as engine idle locking, derating or engine stopping can be happen.

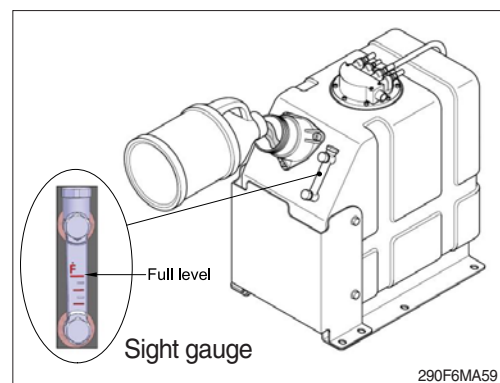

27) REPLACEMENT OF ELEMENT IN HYDRAULIC TANK BREATHER

- (1) Loosen the cap and relieve the pressure in the tank by pushing the top of the air breather.
- (2) Loosen the lock nut and remove the cover.
- (3) Pull out the filter element.
- (4) Replace the filter element new one.
- (5) Reassemble by reverse order of disassembly.
 - Tightening torque : $1.05 \pm 0.21 \text{ kgf} \cdot \text{m}$
($7.6 \pm 1.5 \text{ lbf} \cdot \text{ft}$)

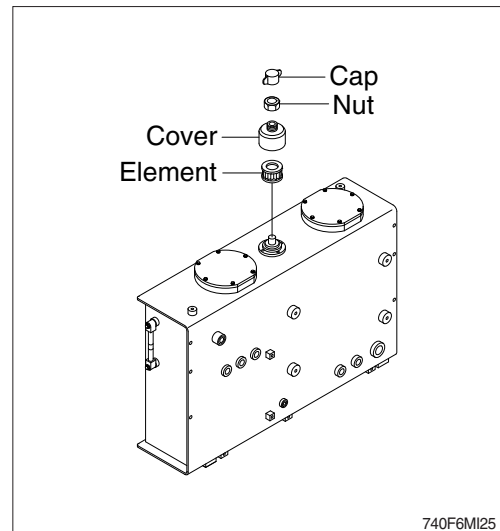

28) REPLACE OF PILOT LINE FILTER

- (1) Loosen the bowl positioned on the safety valve.
- (2) Pull out the filter element and clean the bowl.
- (3) Install the new element and tighten the bowl using spanner.
 - Spanner size : 27 mm

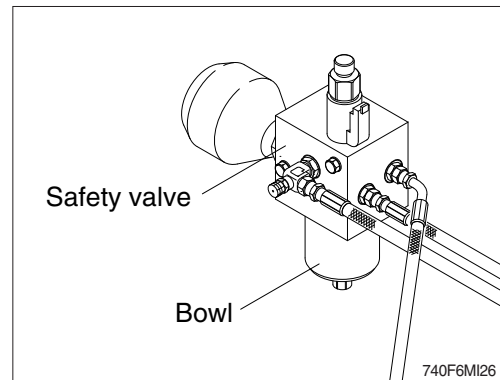

28-1) REPLACE OF PRESSURE FILTER

- (1) Loosen the pressure filter.
 - (2) Install the new filter and tighten.
- ※ Pressure filter is positioned near the upper center pivot pin.

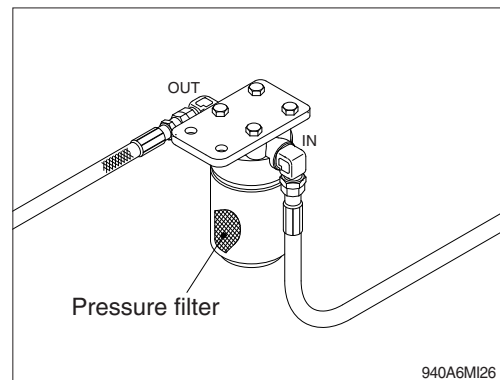

29) LUBRICATE RCV LEVER

Remove bellows and grease the joint (A) and the sliding parts (B).

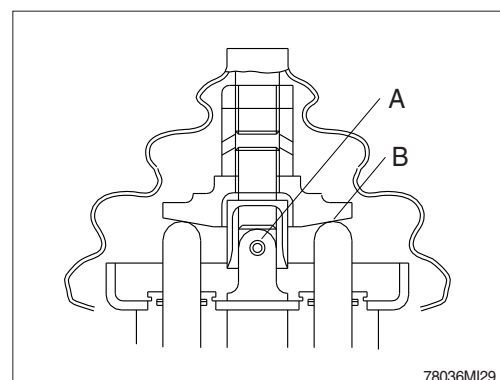

37) REPLACEMENT OF BUCKET TOOTH

(1) Replacement time

Replace the bucket tooth before it has worn out to the end of the bucket.

(2) Replacement method

▲ Make sure the work equipment does not move when replacing the bucket tooth.

Set the work equipment in a stable position, put the pilot cut off switch in the OFF position and stop the engine.

- ① Lift the bucket to a proper height and insert blocks so that the bucket does not fall down.
- ② Loosen bolts and nuts, and remove bucket tooth.
- ③ Clean the contacted surface.
- ※ **If the contacted face of bucket tooth has worn out, repair the contacted face of it.**
- ④ Install new bucket tooth on the bucket, and tighten bolts and nuts.
 - Tightening torque : $57.9 \pm 8.7 \text{ kgf} \cdot \text{m}$
($418 \pm 63 \text{ lbf} \cdot \text{ft}$)
- ⑤ After a few hours of operation, retighten bolts.

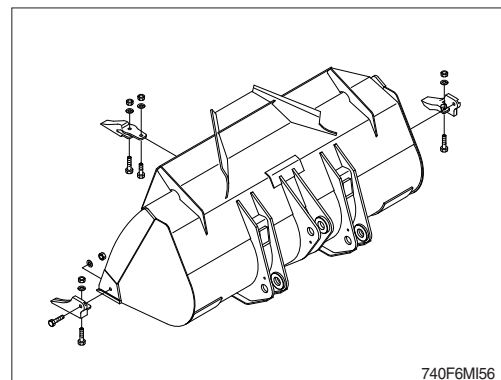
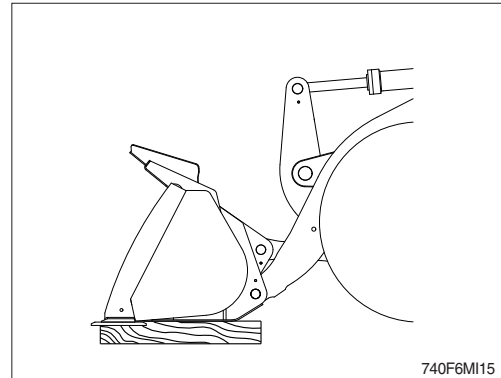

CLICK HERE TO **DOWNLOAD** THE COMPLETE MANUAL

- Thank you very much for reading the preview of the manual.
- You can download the complete manual from: www.heydownloads.com by clicking the link below



- Please note: If there is no response to CLICKING the link, please download this PDF first and then click on it.

CLICK HERE TO **DOWNLOAD** THE COMPLETE MANUAL