

PART NO. EMCGB-1-1

**HITACHI**

# Operator's Manual

# ZAXIS

## 140W-3

## 170W-3

## 190W-3

## 210W-3

## Wheeled Excavator

ZAXIS140W-3 • 170W-3 • 190W-3 • 210W-3 WHEELED EXCAVATOR OPERATOR'S MANUAL

 **Hitachi Construction Machinery Co., Ltd.**  
URL:<http://www.hitachi-c-m.com>



Recycle This book is printed on recycled paper.

PRINTED IN JAPAN (K) 2007, 06

EMCGB-1-1

Serial No.	
ZAXIS140W-3	002001 and up
ZAXIS170W-3	003001 and up
ZAXIS190W-3	002001 and up
ZAXIS210W-3	002001 and up

CLICK HERE TO **DOWNLOAD** THE COMPLETE MANUAL

- Thank you very much for reading the preview of the manual.
- You can download the complete manual from: [www.heydownloads.com](http://www.heydownloads.com) by clicking the link below



- Please note: If there is no response to CLICKING the link, please download this PDF first and then click on it.

CLICK HERE TO **DOWNLOAD** THE COMPLETE MANUAL

# CONTENTS

Monitor Operation.....	1-31	<b>BREAK-IN</b>	
Displaying Basic Screen.....	1-31	Observe Engine Operation Closely.....	2-1
Trip Meter (7).....	1-33	Every 8 Hours or Daily.....	2-1
Odometer (8).....	1-33	After the First 50 Hours.....	2-1
Hour Meter (9).....	1-33	After the First 100 Hours.....	2-1
Clock (18).....	1-33	<b>OPERATING THE ENGINE</b>	
Fuel Gauge (25).....	1-33	Inspect Machine Daily Before Starting.....	3-1
Coolant Temperature Gauge (30).....	1-33	Before Starting Engine.....	3-2
Brake Oil Pressure Gauge (33).....	1-34	Starting the Engine in Ordinary Temperature.....	3-3
Travel Speed Meter (34).....	1-34	Starting in Cold Weather.....	3-6
Tachometer (35).....	1-34	Starting in Cold Weather (ZX140W-3).....	3-8
Back Monitor Screen Selector (22).....	1-38	Check Instruments After Starting.....	3-9
Menu Key (23).....	1-38	Using Booster Batteries.....	3-10
Optional Function Keys (24, 27, 29 and 31).....	1-38	Stopping the Engine.....	3-12
Return-basic Screen Key (32).....	1-38	<b>DRIVING THE MACHINE</b>	
Menu Screen.....	1-41	Traveling.....	4-1
Displaying Basic Screen by Inputting Password (Optional).....	1-42	Engine Speed Control.....	4-2
Corrective Measures to be Taken when a Wrong Password is input.....	1-44	Travel Mode Switch.....	4-3
Extending Password Validity Time.....	1-46	Stopping and Restarting.....	4-4
Alarm Occurrence Screen.....	1-47	Instructions for Traveling on a Slope.....	4-6
Clock Setting.....	1-51	Parking.....	4-7
Work Mode (Attachment Selection).....	1-52	Emergency Parking Due to Machine Failure.....	4-8
Attachment Adjustment (Pump 2 Flow Rate Adjustment).....	1-56	Travel Alarm (Optional).....	4-9
Operating Status.....	1-58	<b>OPERATING THE MACHINE</b>	
Maintenance Setting.....	1-59	Control Lever (ISO Pattern) (Standard).....	5-1
Mail (Optional).....	1-65	Control Lever (Hitachi Pattern).....	5-2
Meter Display Control.....	1-67	Pilot Control Shut-off Lever.....	5-3
Password Revising (Optional).....	1-69	Steering Wheel Column.....	5-4
Back Monitor Setting.....	1-72	Warming-up Operation.....	5-5
Language Setting.....	1-75	Engine Speed Control.....	5-6
Meter Combination Setting.....	1-77	Auto-idle.....	5-7
Unit Setting.....	1-79	Work Mode.....	5-9
Fuse Box.....	1-81	Power Digging (Only ZAXIS210W-3).....	5-11
Additional Fuse Box.....	1-81	Power Mode.....	5-12
Auto Air Conditioner Operation.....	1-82	Parking/Stopping the Machine on a Slope (In Case of Emergency).....	5-14
Tips for Optimal Air Conditioner Usage.....	1-89	Raising the Machine Front Above the Ground with the Boom and Arm Function.....	5-14
Heater (Optional) Operation.....	1-90	Excavation.....	5-15
Am/Fm Radio Operation.....	1-94	Face Shovel Operation.....	5-16
Digital Clock Setting Procedure.....	1-95	Grading Operation.....	5-17
Cab Door Release Lever.....	1-96	Do Not Slam the Bucket Teeth into the Ground.....	5-17
Opening Upper Front Window.....	1-96	Do Not Use the Bucket as a Hammer.....	5-17
Closing Upper Front Window.....	1-97	Avoid Increasing Digging Force Forcibly.....	5-18
Removing and Storing Lower Front Window.....	1-98	Avoid Using Swing Power.....	5-18
Opening Door Windows.....	1-99	Boom Lowering Procedure in Emergency or when the Engine Stalls.....	5-19
Opening/Closing Overhead Window (Std. Model).....	1-100	Overnight Storage Instructions.....	5-21
Emergency Exit.....	1-101	<b>TRANSPORTING</b>	
Adjusting the Seat.....	1-102	Transporting by Road.....	6-1
Seat with a Built-in Heater.....	1-103	Loading/Unloading on a Trailer.....	6-2
Adjusting the Air-suspension Seat (Optional).....	1-104		
Seat with a Built-in Heater.....	1-105		
Seat Belt.....	1-106		

## SAFETY

---

### PRECAUTIONS FOR OPERATIONS

- Investigate the work site before starting operations.
- Be sure to wear close fitting clothing and safety equipment appropriate for the job, such as a hard hat, etc. when operating the machine.
- Clear all persons and obstacles from area of operation and machine movement.

Always beware of the surroundings while operating. When working in a small area surrounded by obstacles, take care not to hit the upperstructure against obstacles.

- When loading onto trucks, bring the bucket over the truck beds from the rear side. Take care not to swing the bucket over the cab or over any person.

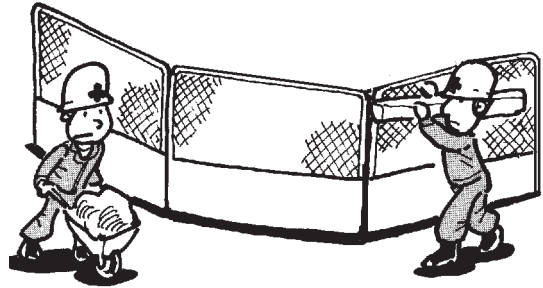
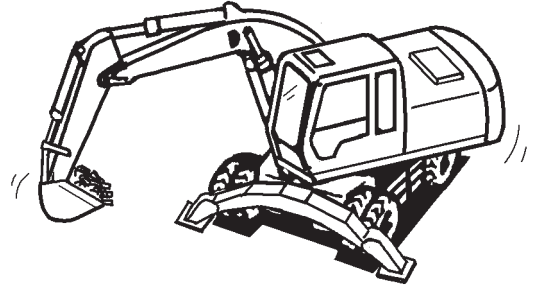

M202-05-014

## SAFETY

### TRANSPORT SAFELY

- Take care the machine may turn over when loading or unloading the machine onto or off of a truck or trailer.
  - Observe the related regulations and rules for safe transportation.
  - Select an appropriate truck or trailer for the machine to be transported.
  - Be sure to use a signal person.
  - Always follow the following precautions for loading or unloading:
    1. Select solid and level ground.
    2. Always use a ramp or deck strong enough to support the machine weight.
    3. Turn auto-idle switch OFF.
    4. Always select the slow speed mode with the travel mode switch.
    5. Never load or unload the machine onto or off a truck or trailer using the front attachment functions when driving up or down the ramp.
    6. Never steer the machine while on the ramp. If the traveling direction must be changed while the ramp, unload the machine from the ramp, reposition the machine on the ground, then try loading again.
    7. The top end of the ramp where it meets the flatbed is a sudden bump. Take care when traveling over it.
    8. Place blocks in front of and behind the tires. Securely hold the machine to the truck or trailer deck with wire ropes.

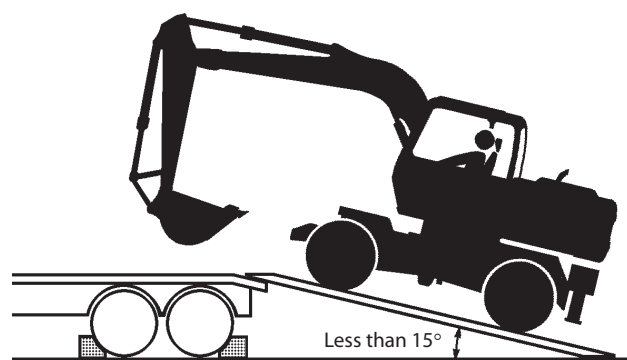

SA-094

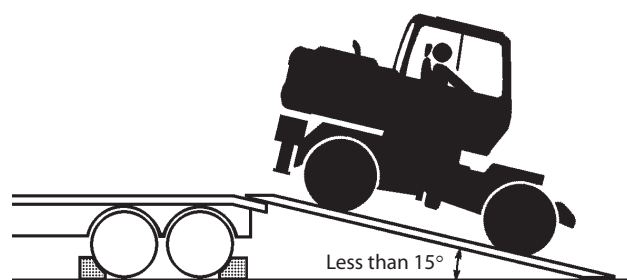

SA-095

Be sure to further follow the details described in the TRANSPORTING section.

035-E07A-0454

## SAFETY

---

### HANDLE CHEMICAL PRODUCTS SAFELY

- Direct exposure to hazardous chemicals can cause serious injury. Potentially hazardous chemicals used with your machine include such items as lubricants, coolants, paints, and adhesives.
- A Material Safety Data Sheet (MSDS) provides specific details on chemical products: physical and health hazards, safety procedures, and emergency response techniques.
- Check the MSDS before you start any job using a hazardous chemical. That way you will know exactly what the risks are and how to do the job safely. Then follow procedures and use recommended equipment.
- See your authorized dealer for MSDS's (available only in English) on chemical products used with your machine.



SA-309

515-E01A-0309

### DISPOSE OF WASTE PROPERLY

- Improperly disposing of waste can threaten the environment and ecology. Potentially harmful waste used with HITACHI equipment includes such items as oil, fuel, coolant, brake fluid, filters, and batteries.
- Use leakproof containers when draining fluids. Do not use food or beverage containers that may mislead someone into drinking from them.
- Do not pour waste onto the ground, down a drain, or into any water source.
- Air conditioning refrigerants escaping into the air can damage the Earth's atmosphere. Government regulations may require a certified air conditioning service center to recover and recycle used air conditioning refrigerants.
- Inquire on the proper way to recycle or dispose of waste from your local environmental or recycling center, or from your authorized dealer.

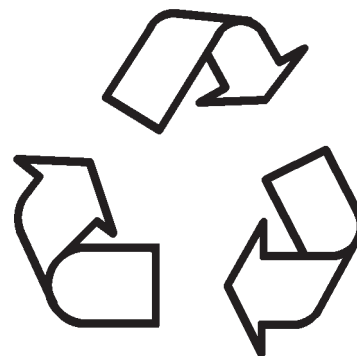

SA-226

516-E01A-0226

## SAFETY SIGNS/Asia/Middle and Near East Model Only

5.

When moving the seat height/tilt lever downward, press the lever grip with a palm from the top side. Do not grasp the lever grip to operate the lever, possibly resulting in pinch of your fingers into the seat stand.

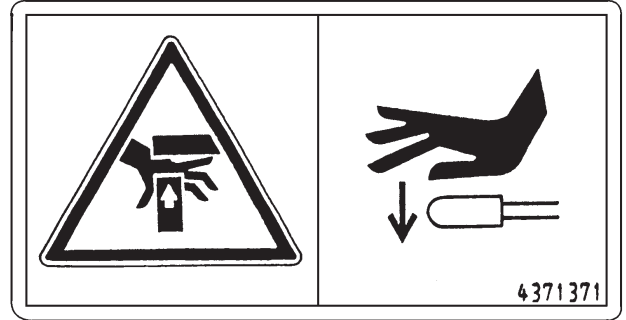

SS-955

6.

If the machine should overturn, the operator may become injured and/or throw from the cab and/or crushed by the overturning machine.

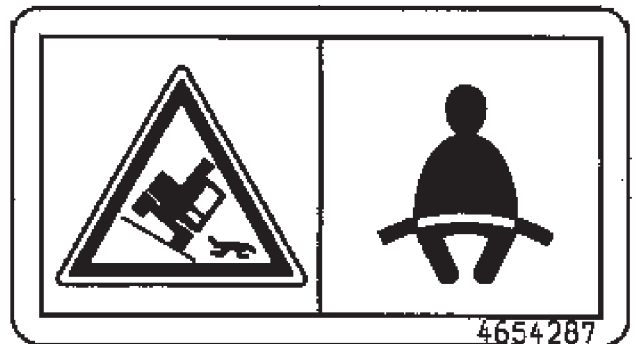

SS4654287

7.

Do not extend your hands or head from the window. Your hands or head may come in contact with the boom.

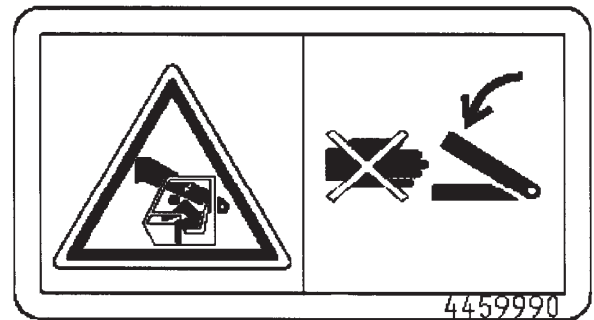

SS4459990

8.

**⚠ WARNING**

- Before operating machine always ensure to :
  - Read and understand the Operator's Manual.
  - Understand the location and function of each control.
  - Sound the horn to alert people nearby, and ensure all persons are clear of work area.
  - Always be aware of the Auto-Idle ON/OFF condition.
- Always ensure when leaving operator's seat to :
  - Lower bucket or other working tools to the ground.
  - Set the parking brake.
  - Place pilot control shut-off lever in OFF position.
  - Turn key OFF and remove from switch.
- Never go under machine while track is raised with the boom and arm.
- When loading or unloading machine from a trailer always ensure the Auto-Idle and H/P switches are OFF.
- When retracting arm with reversed-installed bucket use caution not to hit cab.
- In case the machine must be operated with insufficient visibility, use a signal person and be sure to follow his instructions.

3111971

SS3111971

# OPERATOR'S STATION

## F-N-R LEVER

**WARNING:** When the upperstructure is rotated 180°, travel and steering control directions are reversed. Use extra care when travel in.

Change forward/reverse travel direction by operating this lever.

When F-N-R lever (1) is operated, corresponding indicator (2, 3, or 4) will come ON.

- 2- F (Forward)
- 3- N (Neutral)
- 4- R (Reverse)

1. Place F-N-R lever (1) in neutral during machine operation or when to park or stop the machine.
2. Avoid shifting F-N-R lever (1) to neutral or to the reverse direction of travel quickly during traveling. In case braking performance is reduced during traveling, the machine can be stopped by operating F-N-R lever (1) reversely. However, only use this operation in case of emergency.

**NOTE:** The engine does not start unless F-N-R lever (1) is in the neutral position.

**IMPORTANT:** While traveling, do not turn the forward/reverse travel switch to neutral or to the opposite direction of travel. Failure to do so may result in damage to the travel motor.

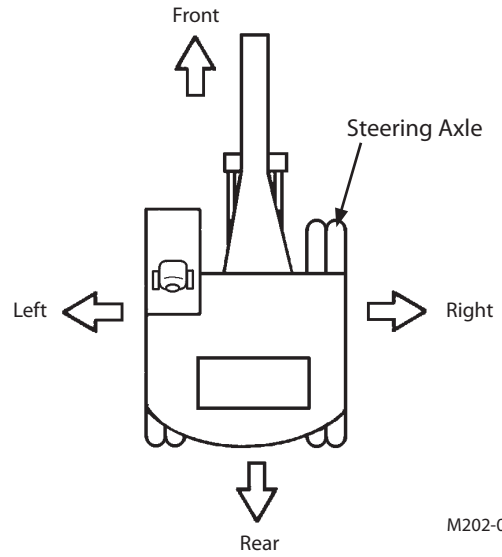

M202-01-003

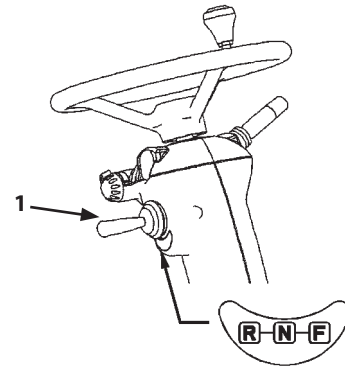

MCGB-01-058

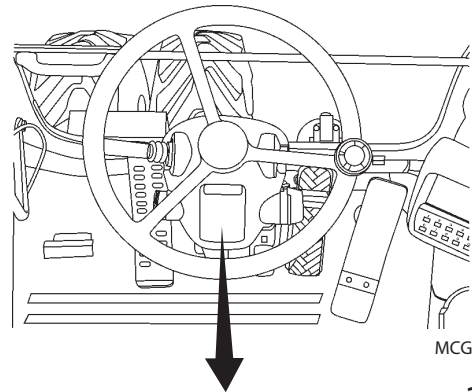

MCGB-01-002

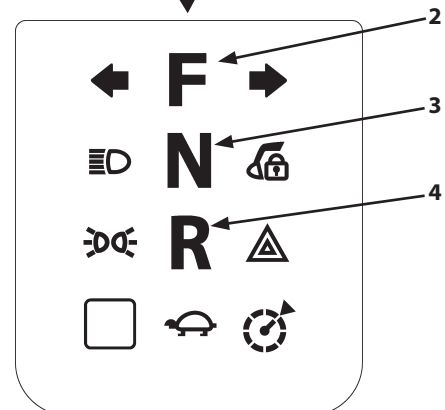

TCJB-01-02-004

## OPERATOR'S STATION

---

### Power Mode Switch

One of three engine speed modes, E, P or H/P mode, can be selected by operating power mode switch (1).

- E (Economy) Mode

Although production rate slightly decreases than the P mode, the machine can be operated with less fuel consumption and noise levels.

- P Mode

Operate the machine in this mode when performing normal work.

- H/P (High Power) Mode

When rolling in the arm while digging deep trenches for example, more power may be required. In such cases, use the H/P mode.

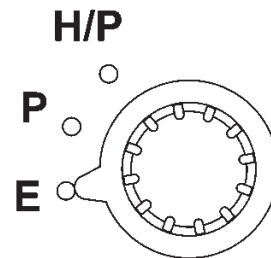

M178-01-013

## OPERATOR'S STATION

### LIGHTER

#### Operation

**IMPORTANT:** In case the lighter doesn't pop out automatically 30 seconds after pushing the lighter in, pull out the lighter manually. Then, consult the your nearest Hitachi dealer.

1. Turn key switch (1) to the ACC or ON position.
2. Press and release the lighter knob.
3. The lighter knob will return to the original position when the lighter becomes usable. Pull the lighter out to use.
4. After using the lighter, insert the lighter into the panel until the knob is seated in the original position.

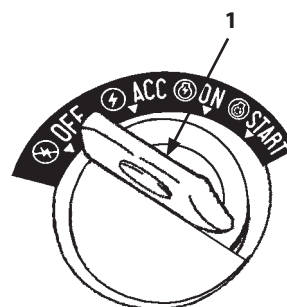

M178-01-049

#### Using Lighter Port as External Power Source

Use the lighter port to supply power to some equipment such as lighting equipment for servicing the machine.

**IMPORTANT:** Only 24 V electric power is available from the lighter port on this machine. Never connect accessories that use power other than 24 V. Damage to the batteries and accessories may result.

**Don't supply power to accessories for a long time without running the engine. Failure to do so may discharge the batteries.**

1. Pull the lighter knob out.
2. Correctly insert the accessory socket into the lighter port.
3. Turn key switch (1) to the ACC or ON position. Power is supplied to the connected accessory.
4. After using the accessory, disconnect the accessory socket and insert the lighter knob into the port.

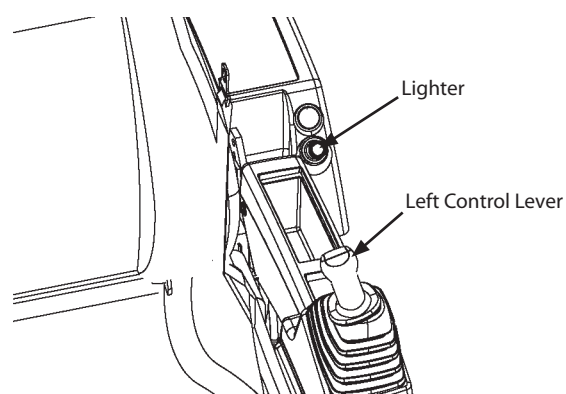

M1U1-01-021

## OPERATOR'S STATION

- Auto-idle indicator (2)

Is displayed when the auto-idle switch on the switch panel is turned ON. In addition, this indicator flashes for 10 seconds after the key switch is turned ON.

- Overload alarm indicator (3)



TCJB-05-02-061

Displays the alarm when the boom cylinder bottom pressure sensor detects overloading.

- Auto-axle lock indicator (4)

Is displayed when the brake switch is turned to the auto-axle lock position.

- Parking brake indicator (10)

Comes ON in red when the parking brake is activated. [Brake switch: P (parking) position]

- Work brake indicator (11)

Comes ON in red when the work brake is activated.

- Axle lock indicator (12)

Comes ON in red when the axle lock is activated. [Brake switch: Axle lock or auto-axle lock position]

**NOTE:** When the front attachment control levers are in neutral with the brake switch in the auto-axle lock, auto-axle indicator (4) and axle lock indicator (12) come ON. At this time, when the accelerator pedal is stepped on, the axle lock is released by the auto-axle control system, turning axle lock indicator (12) OFF. However, auto-axle lock indicator (4) is kept ON as the brake switch is in the auto-axle lock position.

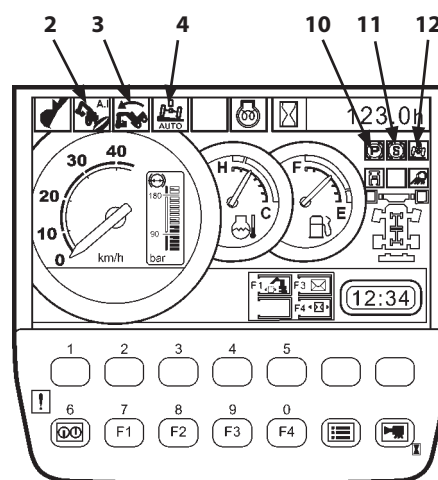

MCGB-01-038

# OPERATOR'S STATION

## Extending password validity time

**IMPORTANT:** This operation is applicable only to those machines that display the basic screen based on password input.

The password validity time that was input when starting the engine on extension screen (1), is extended. Accordingly, the monitor can be operated without inputting the password when the engine is restarted in the extended validity time.

1. Turn the key switch OFF. The monitor unit displays extension screen (1) for 10 seconds.

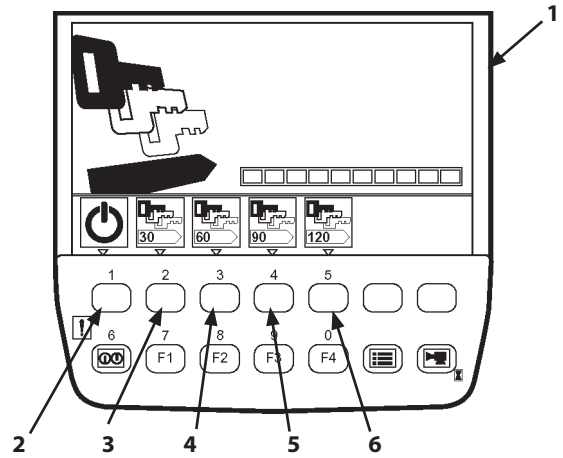

Extension Screen (Key Switch OFF)

T1V1-05-01-012

2. Press a time extension key before extension screen (1) disappears to assign the password validity extension time as follows:

Key (2): 0 minute

Key (3): 30 minutes

Key (4): 60 minutes

Key (5): 90 minutes

Key (6): 120 minutes

 **NOTE:** In case time extension operation is not done, 0-minute extension time is set.

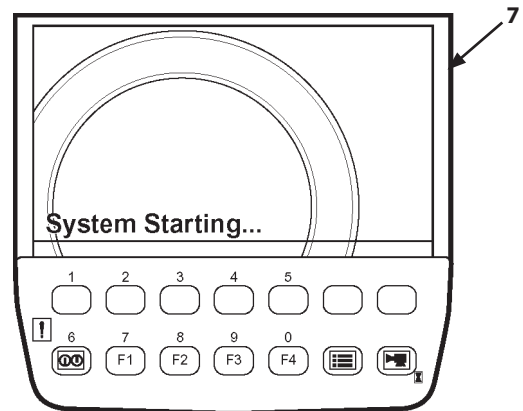

Key Switch ON

T1V1-05-01-115

3. When the key switch is turned ON before the password validity time expires, the monitor unit displays starting screen (7) and basic screen (8) in series.

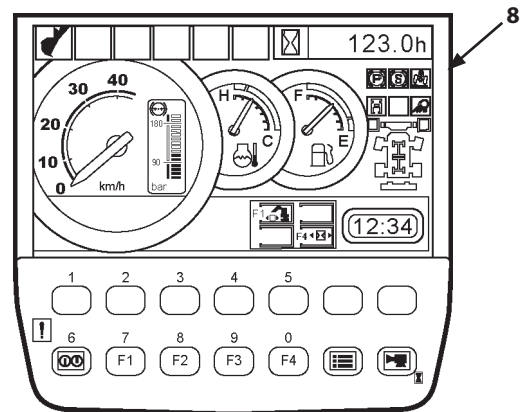

Basic Screen

MCGB-01-041

## OPERATOR'S STATION

### ATTACHMENT ADJUSTMENT (PUMP 2 FLOW RATE ADJUSTMENT)

 **NOTE:** The monitor unit is operable only when the machine is equipped with an optional attachment.

**IMPORTANT:** This operation is effective when an optional attachment is installed.

**When breaker 1 or 2 is used:**

1. After displaying basic screen (1), press menu key (2) to display main menu (3).
2. Select attachment adjustment menu (7) on the main menu screen by operating key (4 or 5). Press determination key (6) to display attachment adjustment screen (8).
3. Adjust pump 2 flow rate by operating keys (4 and 5).  
When using breaker 1 or 2, the pump 2 flow rate is reduced by pressing key (4) or increased by pressing key (5).

 **NOTE:** Press key (10) to return to the previous screen.

4. Press key (9) to display basic screen (1).

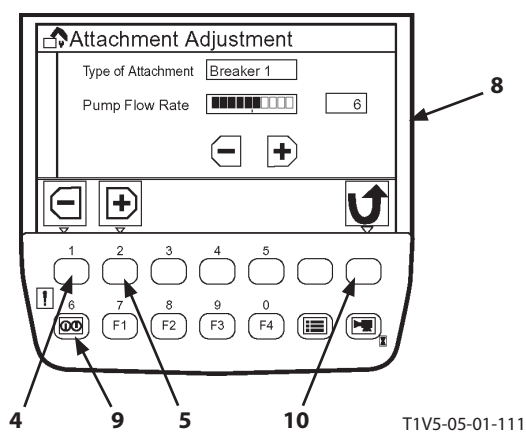
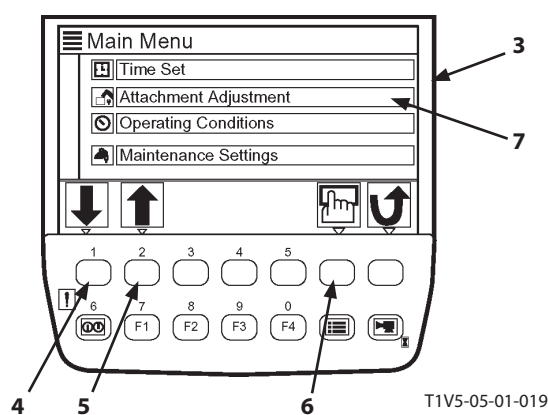
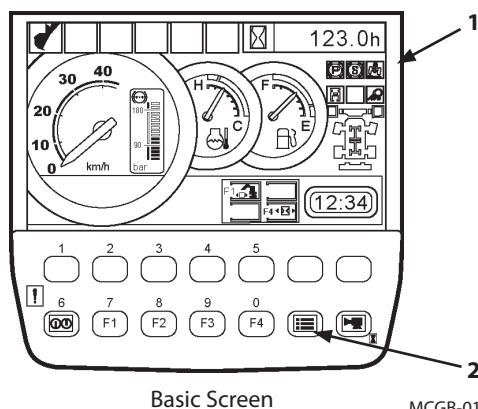

## OPERATOR'S STATION

 **NOTE:** If the satellite communication terminal fails to send a mail, the message "Mail transmission failed" is displayed on screen (11).

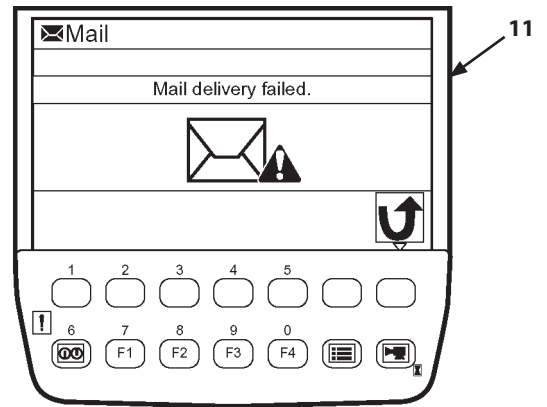

T1V5-05-01-040

## OPERATOR'S STATION

### Lists of Display Language

#### Display Languages 1

Language	Screen Display	
Japanese	日本語	T1V1-05-01-141
English	English	T1V1-05-01-142
Chinese (Simplified)	简体中文	T1V1-05-01-143
Chinese (Traditional)	繁體中文	T1V1-05-01-144
Korean	한국어	T1V1-05-01-145
Indonesian	Bahasa Indonesia	T1V1-05-01-146
Thai	ภาษาไทย	T1V1-05-01-147
Vietnamese	Tiếng Việt	T1V1-05-01-148
Myanmarese	မြန်မာဘာသာ	T1V1-05-01-149
Arabic	اللغة العربية	T1V1-05-01-150
Persian	اللغة الفارسية	T1V1-05-01-151
Turkish	Türkçe	T1V1-05-01-152

#### Display Languages 2

Language	Screen Display	
English	English	T1V1-05-01-142
Spanish	Español	T1V1-05-01-153
Italian	Italiano	T1V1-05-01-154
French	Français	T1V1-05-01-155
German	Deutsch	T1V1-05-01-156
Dutch	Nederlands	T1V1-05-01-157
Russian	Русский	T1V1-05-01-158
Portuguese	Português	T1V1-05-01-159
Finnish	Suomi	T1V1-05-01-160
Swedish	Svensk	T1V1-05-01-161
Norwegian	Norsk	T1V1-05-01-162
Danish	Dansk	T1V1-05-01-163

## OPERATOR'S STATION

- Air Conditioner (A/C) Switch (8)

Press A/C switch (8) to turn the air conditioner and the A/C indicator ON. However, unless the blower is running (the fan display of blower switch (6) is lit), the air conditioner will not be turned ON.

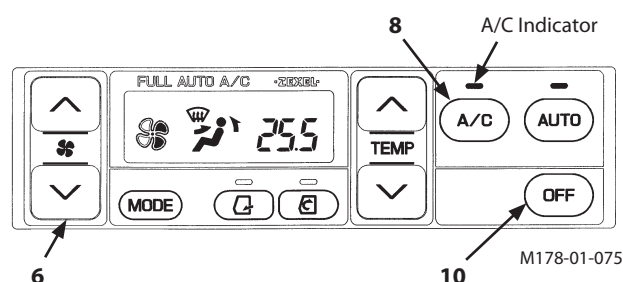

Display when Air Conditioner Switch (8) is pressed.

- OFF Switch (10)

Press OFF switch (10) to turn the blower and the air conditioner OFF.

- AUTO Switch (9)

Press AUTO switch (9) to turn the AUTO and the A/C indicators ON so that the air flow-in temperature at the vent, blower speed, vent locations, and fresh air suction port are automatically controlled.

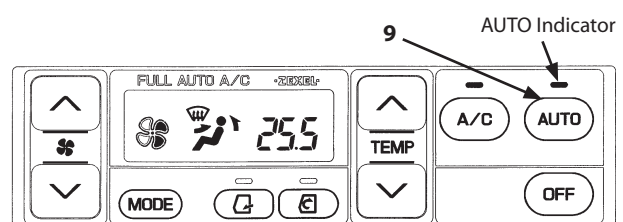

Display when AUTO Switch (9) is pressed.

### Selecting Display between Celsius and Fahrenheit

1. While depressing both A/C (8) and mode (14) switches, turn the key switch ON.
2. The LCD will display "Sd" for approx. 5 seconds.
3. After display "Sd" disappears, all indicators will come ON.
4. After all indicators come ON, repeat to press the button of blower switch (6) four times.
5. Sequentially, press A/C switch (8) and the button of blower switch (6) at the same time.
6. Then, the selection mode between Celsius and Fahrenheit starts. Each time fresh air mode switch (13) is pressed, the display is shifted between Celsius and Fahrenheit.  
When Celsius is selected, the LCD displays "C."  
When Fahrenheit is selected, the LCD displays "F."  
Select either one to be preferred.
7. After selection is complete, end by turning the key switch "OFF".

The LCD will display in the selected mode when the machine is operated next time.

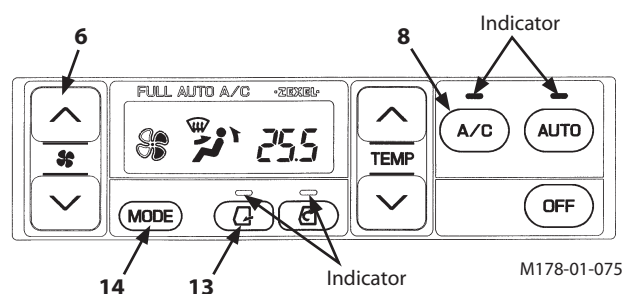

	Display on LCD
Celsius (°C)	18.0 to 32.0
Fahrenheit (°F)	63 to 91

## OPERATOR'S STATION

### CAB DOOR RELEASE LEVER

**CAUTION:** When desired to open the cab door, open the cab door all the way until it securely locks in the latch on the side of the cab.

To unlock the door from this position, push down on lever (1).

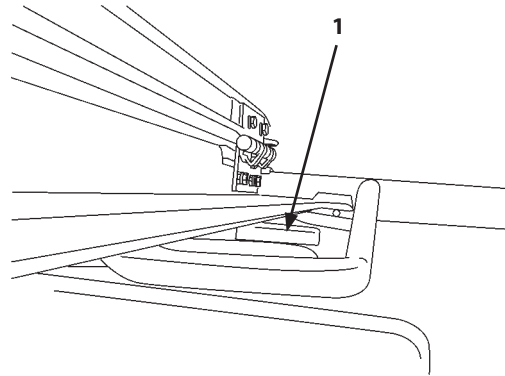

M1J1-07-051

### OPENING UPPER FRONT WINDOW

**WARNING:** Open or close the upper-front cab window only after pulling up the pilot control shut-off lever to the LOCK position. Failure to do so may allow the machine to move unexpectedly if a control lever is touched a part of the body by mistake, possibly resulting in personal injury or death.

1. Press lock release lever (2) at the upper center of the inside cab to release the upper front window lock.
2. While holding upper lock release lever (2) and the lower handles on the upper front window, pull the upper front window up and back until auto locks (4) provided at the upper section of the front window frame securely catches into strikers on the cab ceiling.

**CAUTION:** Always secure lock pin (3) in the lock position after the upper front window is opened.

3. After confirming that the auto locks (4) securely catches into strikers, slide lock pin (3) into the right bracket boss hole to lock the window in position.

**NOTE:** When the upper front window is opened, the wiper and washer are inoperable.

**IMPORTANT:** If the front window is opened or closed with the steering wheel column in the upright position, the steering wheel will come in contact with the front window. Always tilt the steering wheel column backward before opening or closing the front window.

**CAUTION:** When closing the upper front window, slowly lower the window while taking care not to pinch your fingers. After upper front window is opened, always slide lock pin (3) to the LOCK position.

4. When closing the upper front window, reversely follow the procedures in steps 1, 2 and 3. Release auto lock (4) by lowering the lock release lever.

**NOTE:** Unless the upper front window is completely closed, the wiper is inoperable.

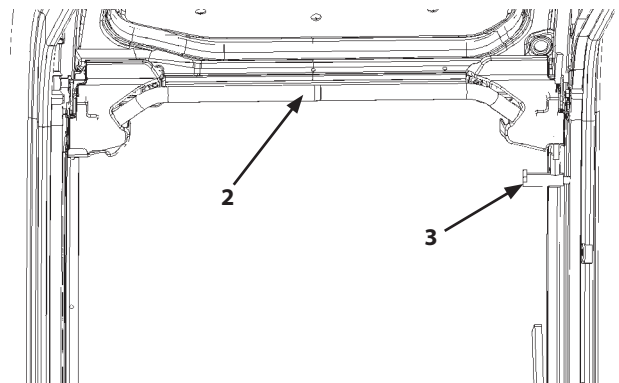

M1U1-01-028

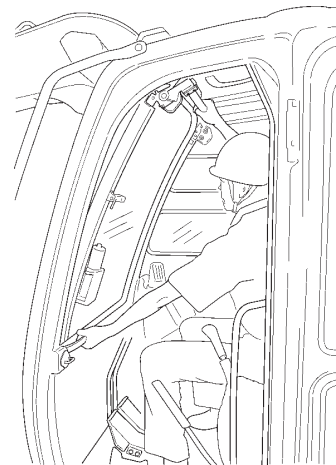

M1CC-01-020

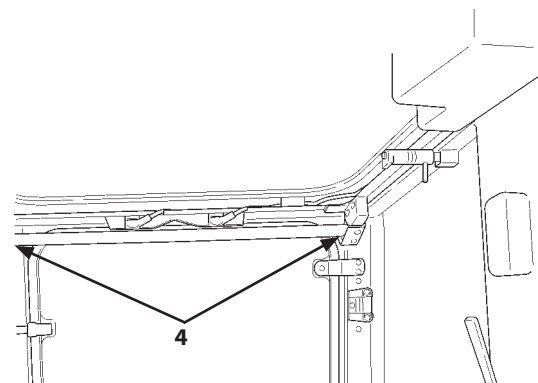

M1CC-01-031

## OPERATOR'S STATION

### SEAT BELT

**CAUTION:** Be sure to use the seat belt when operating the machine. Before operating the machine, be sure to examine the seat belt, buckle, and attaching hardware. Replace the seat belt, buckle, or attaching hardware if they are damaged, or worn. Replace seat belt every three years, regardless of appearance.

#### Fastening and Unfastening Seat Belt

1. Confirm that seat belt (1) is not twisted. Securely insert the end of seat belt (1) into buckle (2). Lightly pull on the belt to confirm that the buckle latches securely.
2. Push button (3) on buckle (2) to unfasten seat belt (1).

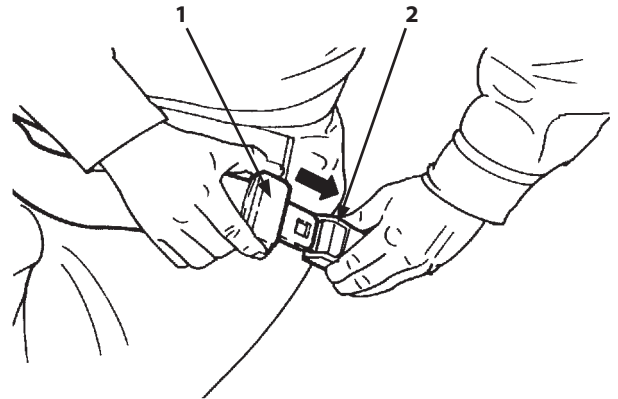

MCGB-01-027

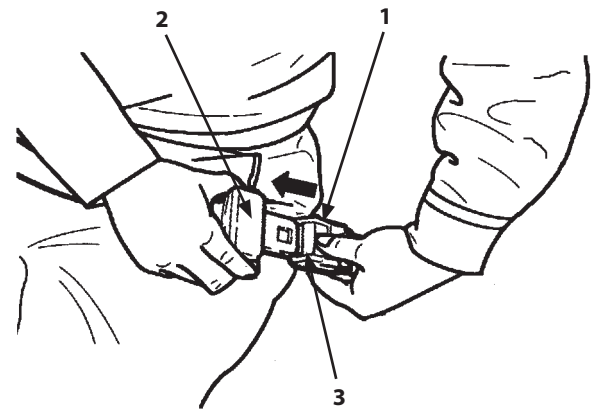

MCGB-01-028

## OPERATING THE ENGINE

### STARTING IN COLD WEATHER (ZX140W-3)

In extremely low temperature, the engine may not readily start.

If this is the case, follow the procedure below.

#### Pre-cranking

Turn key switch (1) to START position for 30 seconds.  
Then, turn key switch (1) OFF.

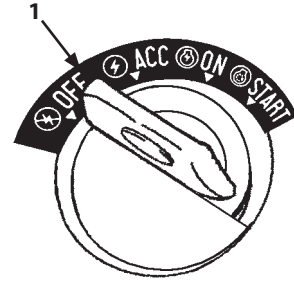

M178-01-049

#### Without Cranking

To prevent starter damage, turn key switch (1) to ON position for 15 seconds until preheat indicator goes OFF.

#### Cranking for Engine Start

Again, turn key switch (1) to START position.

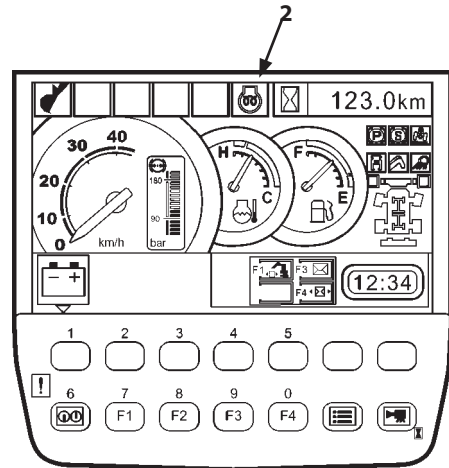

MCGB-03-003

CLICK HERE TO **DOWNLOAD** THE COMPLETE MANUAL

- Thank you very much for reading the preview of the manual.
- You can download the complete manual from: [www.heydownloads.com](http://www.heydownloads.com) by clicking the link below



- Please note: If there is no response to CLICKING the link, please download this PDF first and then click on it.

CLICK HERE TO **DOWNLOAD** THE COMPLETE MANUAL

## DRIVING THE MACHINE

---

### INSTRUCTIONS FOR TRAVELING ON A SLOPE



#### WARNING:

- **Primarily use hydraulic pressure brake (relief pressure) when descending a slope. Step on the brake pedal only when required. If only the foot brake is used, the brake will overheat, decreasing brake performance and possibly causing a personal accident. In case the brake system overheats, immediately park the machine in a safe area. Wait for the brake system to cool before restating to travel the machine.**
- **When descending a long slope continuously, hydraulic oil temperature in the travel circuit may increase. Occasionally step on the accelerator pedal to slacken increasing oil temperature sharply.**



#### CAUTION:

- **Do not descend a slope with the forward/reverse switch kept in neutral. Damage to the travel motor may result.**
- **If hydraulic oil temperature in the travel circuit overheats, damage to the hydraulic components may result.**
- In case the engine stalls on a slope, be sure to depress the brake pedal and turn the brake switch to "P" (parking) position. Then, restart the engine.
- Before descending a slope, operate the brake to check that the brake operates normally.
- When hydraulic oil and/or lubricant is not warmed up, gradeability may be reduced. Before ascending a steep slope, sufficiently perform warm up operation of the machine.

## OPERATING THE MACHINE

### ENGINE SPEED CONTROL

Increase and decrease the engine speed using engine control dial (1) located on the switch panel.

- Turn engine control dial (1) clockwise to increase the engine speed. Turn engine control dial (1) counterclockwise to decrease the engine speed.
- Note that the auto-idle function will be deactivated if engine control dial (1) is operated while the engine is running in the auto-idle mode.
- Before stopping the engine, always turn engine control dial (1) counterclockwise to the stop (to the slow idle setting). Run the engine five minutes to cool the engine. Then, turn key switch to OFF position to stop the engine.

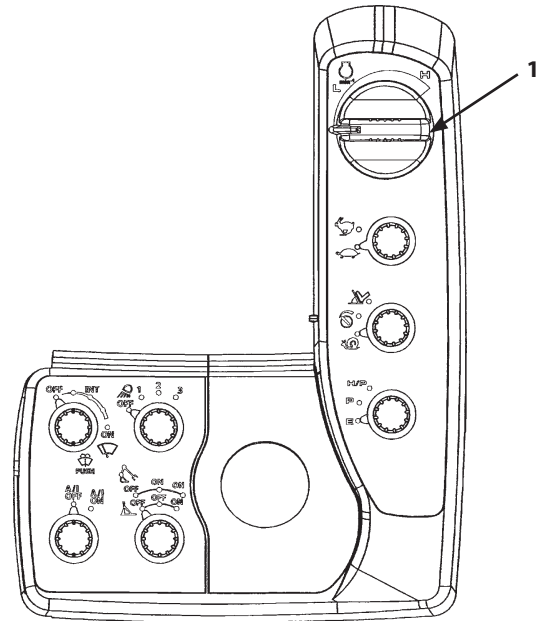

TCJB-01-02-003

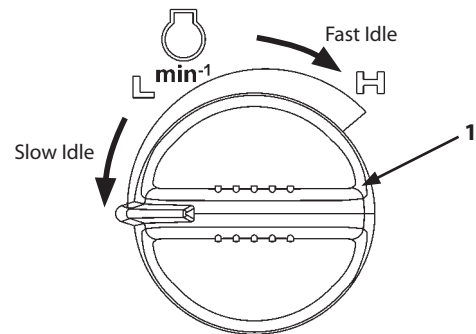

M1U1-01-033

## OPERATING THE MACHINE

### FACE SHOVEL OPERATION

In contrast with that the backhoe rolls the bucket in to excavate, the face shovel rolls the bucket out.

**⚠ WARNING:** When the bucket is reversely installed in face shovel operation, the bucket may come in contact with the cab when the arm is fully rolled in. Be careful not to allow the bucket to hit the cab when the arm is fully rolled in.

**IMPORTANT:** When the bucket with a hook is installed, operate the bucket and arm with care so as not to allow the bucket hook to come in contact with the arm.

- For face shovel operation, dig the ground using the arm cylinder in a scraping motion.
- When underground water is expected, make a slope angle of 2 to 3° to drain this water as shown.

**✎ NOTE:** When the bucket is installed reversely, the bucket digging force is less than the backhoe due to the design construction of the hydraulic cylinder.

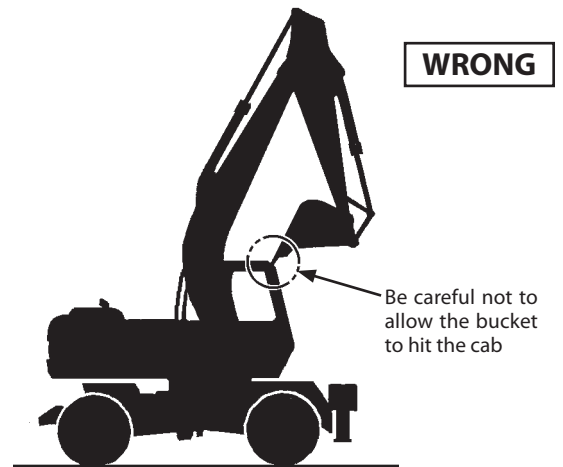

M202-05-040

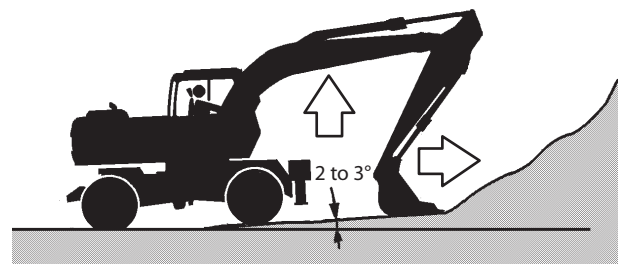

M202-05-019

## TRANSPORTING

---

6. Stop the engine. Remove the key from the key switch.
7. Operate the control levers several times to release any remaining pressure from the cylinders.
8. Place the pilot control shut-off lever in the LOCK position.
9. Be sure to close the cab windows, overhead window, and door to prevent entry of wind and rain into the cab. Put a cover on the exhaust opening.
10. Store the mirror, handrails, and radio antenna in the specified positions.

 **NOTE:** *In cold weather, be sure to warm up the machine before loading or unloading the machine.*

## TRANSPORTING

 **WARNING:** During transportation, the machine carried with a trailer is vibrated or swayed in all directions.  
**Securely fasten the machine to the trailer deck using chains or cables.**

1. Turn the brake switch to the P (parking) position. Place blocks in front of and behind the tires.
2. Fasten the base machine and the front attachment to the trailer using wire ropes.

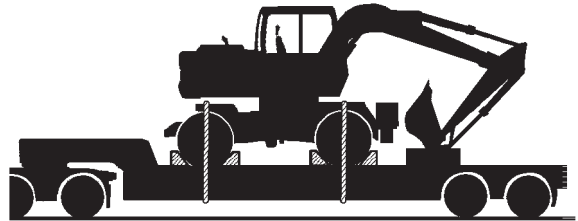

MCGB-06-001

# MAINTENANCE

## PREPARE MACHINE FOR MAINTENANCE

Before performing the maintenance procedures given in the following chapters, park the machine as described below, unless otherwise specified.

1. Park the machine on a level surface.
2. Lower the bucket to the ground.
3. Turn brake switch (3) on the column console to the P (parking) position.
4. Turn the auto-idle switch OFF.
5. Place forward/reverse switch (2) to N (neutral).



**IMPORTANT: The turbocharger may be damaged if the engine is not properly shut down.**

6. Turn the engine control dial to the slow idle position. Place accelerator pedal to neutral. Run the engine at slow idle speed to cool the engine for 5 minutes.
7. Turn the key switch OFF. Remove key from switch. (If maintenance must be performed with engine running, do not leave machine unattended.)
8. Pull the pilot control shut-off lever (1) to the LOCK position.
9. Before starting repair work, attach a Do Not Operate tag in an easy-to-see place such as on the cab door or control lever.

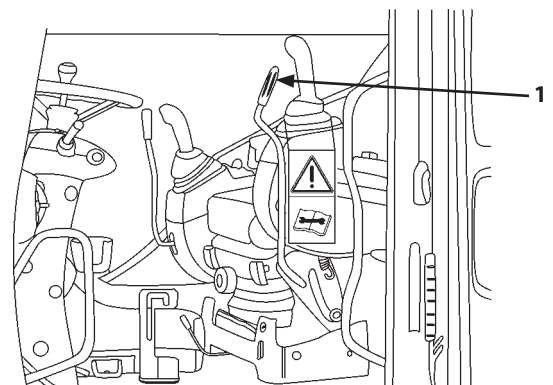
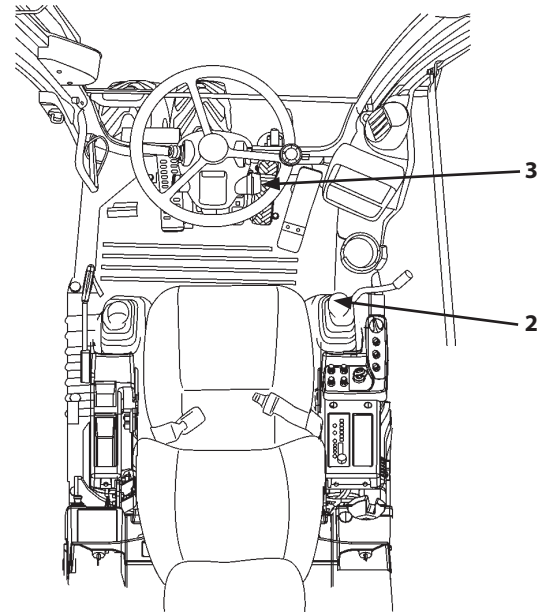

## MAINTENANCE

---

- Boom and Arm Joint Pin, Arm Cylinder Rod Pin and Bucket Cylinder Bottom Pin.

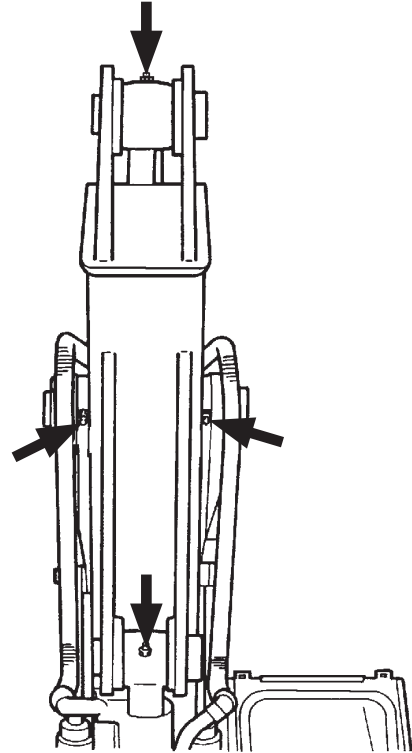

M157-07-157

- Boom Cylinder Rod Pins and Arm Cylinder Bottom Pin.  
(Centralized greasing system)

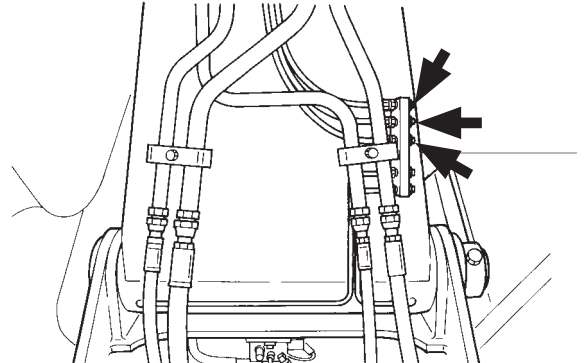

M157-07-155

# MAINTENANCE

## C. TRANSMISSION

### 1 Pump Transmission

#### Check Oil Level --- every 250 hours

1. Park the machine on a level surface.
2. Lower the bucket to the ground.
3. Turn the auto-idle switch off.

**IMPORTANT: The turbocharger may be damaged if the engine is not properly shut down.**

4. Run the engine at slow idle speed without load for five minutes.
5. Stop the engine. Remove the key from the key switch.
6. Pull the pilot control shut-off lever to the LOCK position.
7. Remove dipstick (1). Oil must be within the specified range.
8. If necessary, remove filler plug (2) and add oil. (See gear oil chart)
9. Recheck oil level.

#### Change Oil --- every 1000 hours

1. Park the machine on a level surface.
2. Lower the bucket to the ground.
3. Turn the auto-idle switch off.

**IMPORTANT: The turbocharger may be damaged if the engine is not properly shut down.**

4. Run the engine at slow idle speed without load for five minutes.
5. Stop the engine. Remove the key from the key switch.
6. Pull the pilot control shut-off lever to the LOCK position.

**CAUTION: Oil may be hot. Wait for oil to cool before starting work.**

7. Remove filler plug (2).
8. Remove drain plug (3). Allow oil to drain through a clean cloth into a 2 liter (0.52 US gal) container.
9. After all oil has drained, inspect cloth for any debris such as small pieces of metal.
10. Reinstall the drain plug (3).
11. Add oil via filler plug (2) until it is within the specified range on dipstick (1).
12. Reinstall filler plug (2).

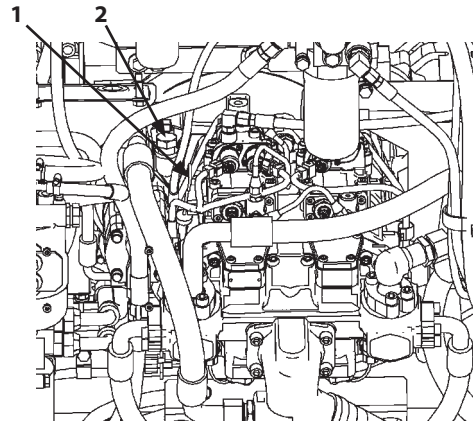

MCGB-07-026

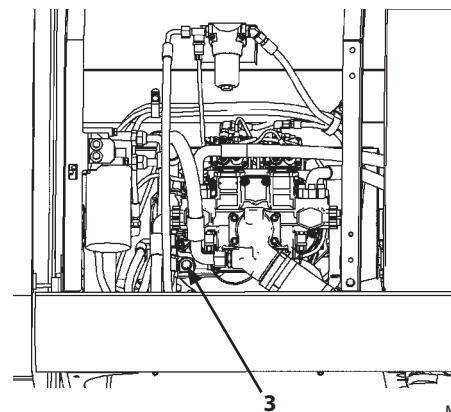

MCGB-07-025

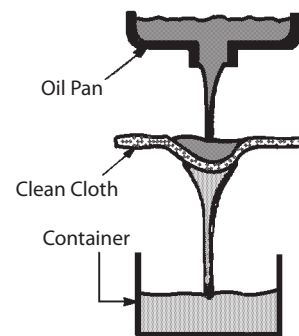

M104-07-010

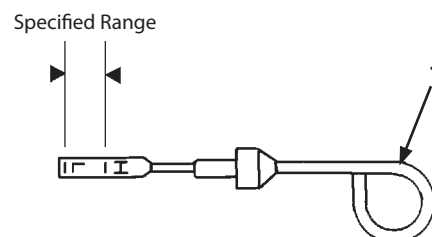

M1G6-07-004

## MAINTENANCE

---

### **1** Tire Inspection and Replacement Procedure

#### **Inspection**

1. If the tread of any part of a tire has worn down, replace the tire.
2. Each day before starting work, be sure to check the tires for cracks, damage, foreign matter, etc.
3. Confirm that the tire pressure is within specifications.

#### **Remove and Install tires following these procedures**

##### **Removal**

1. Loosen the wheel nuts with a wheel wrench. Right-handed Screws are used for both the right-hand and left-hand wheels.
2. Jack up the machine body until the tire clears the ground. Remove tire.
3. Stop the engine. Put the shift lever in the neutral position. Turn the key switch to the ON position.
4. Remove tire.

##### **Installation**

1. To avoid excessive tightening torque, Do not use the oil containing molybdenum dioxide.
2. Apply engine oil to thread of nut and washer facing surface of nut slightly.
3. Pre tightening the wheel nut diagonally with 2-3 processes, then apply regular tightening torque.  
Tightening torque : 650 N·m (66 kgf·m, 480 lbf·ft )
4. Must not apply engine oil to disk wheel facing surface of the washers.

## MAINTENANCE

### 4 Replace Full-Flow Filter (Optional) --- every 300 hours

In case the hydraulic oil filter indicator on the monitor panel comes ON, immediately replace the filter even if operation hours are shorter than 300 hours after replacing the filter previously.

**CAUTION:** Immediately after operating the machine if hydraulic system or line is opened, hot and high pressure hydraulic oil may spout, possibly causing severe burns. Wait for the hydraulic oil to cool before starting any maintenance work.



M202-07-028

**IMPORTANT:** Replacement intervals differ according to the brand of hydraulic oil used and the kind of the filter element used, as well as the operating hour ratio of the installed attachment.

#### IMPORTANT: Precautions for Using Element

- High performance element (micro-glass) is used in the full-flow filter element on Excavators for Demolition Work. Be sure to replace the filter with the same type of high performance element. In case using a filter-paper element is unavoidable, refer to the descriptions for replacing hydraulic oil and full-flow filter element in the MAINTENANCE section.
- In case the same filter paper element as used on Std. Model, the filter restriction indicator will not operate. Insulate the harness to indicator (7).

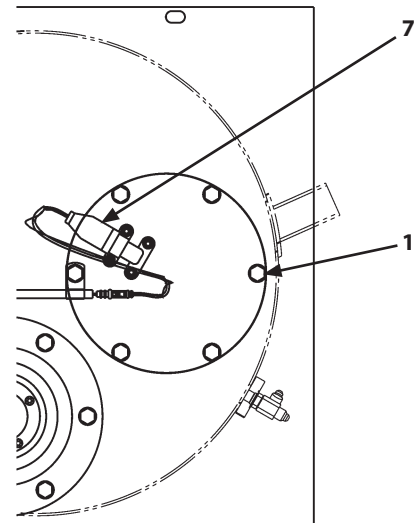

#### Replacement

1. Park the machine on solid and level ground. After extending the bucket cylinder, retracting the arm cylinder, and lowering the bucket on the ground, as illustrated to the right, stop the engine.
2. Be sure to push the air vent valve to release any air pressure from the hydraulic oil tank before replacing the element.
3. Remove bolts (1) (6 used) to remove cover (2) and O-ring (3). When removing cover (2), slowly remove it while pressing the cover downward so that spring (4) doesn't fly out.
4. Remove spring (4) and element (5).
5. Replace element (5) and O-ring (3) with new ones. Install them into the hydraulic oil tank.
6. Install cover (2). Tighten bolts (1) (6 used) to specification.  
Tightening Torque: 50 N·m (5.1 kgf·m, 37 lbf·ft)

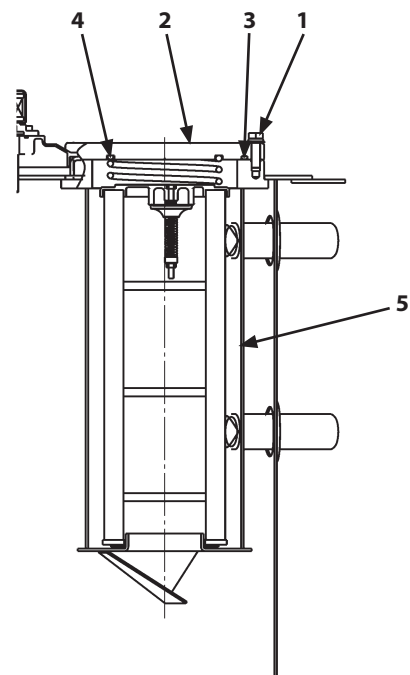

M175-07-035

# MAINTENANCE

## 2 Check Water Separator --- daily

Water separator (4) separates any water that may get mixed with the fuel. Water separator (4) contains a float which rises as water accumulates.

Be sure to drain the sediment when the float rises up to the "Drain Water" mark written on the outside of water separator (4).

**IMPORTANT: If the fuel contains an excessive amount of water, shorten the interval between water separator checks.**

### Draining Procedures (Main Filter)

1. Place 0.5 liters or larger capacity container under drain plug (3) to collect the drained water.
2. Shut off the fuel supply by closing cock (3) on the bottom of the fuel tank.
3. Loosen plug (1) on the top of the fuel main filter.
4. Rotate drain plug (2) on the bottom of the filter about 4-turns counterclockwise to drain the water accumulated in the filter.
5. After draining water, securely tighten drain plug (2) and plug (1). Return fuel cock (3) to the original position.
6. Start the engine. Check drain plug (3) and plug (1) for fuel leaks.

Wrench size: 10 mm

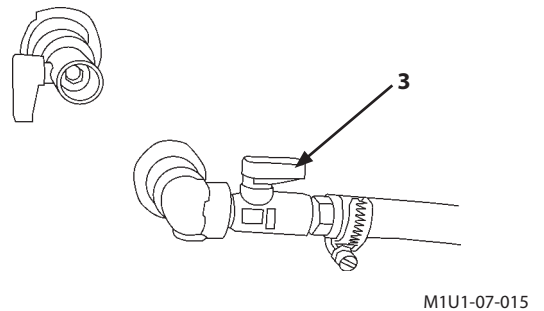
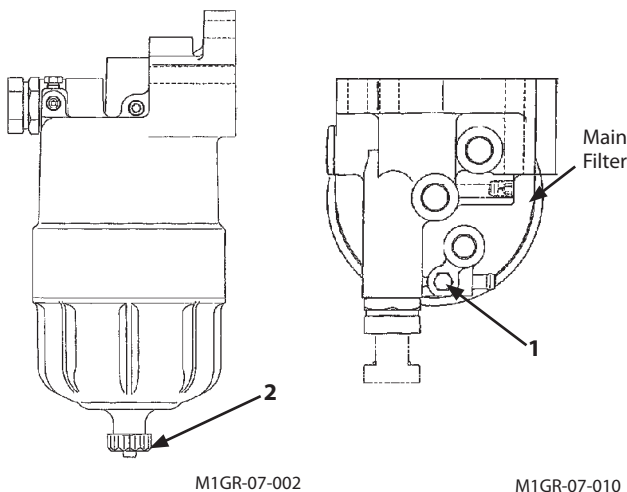
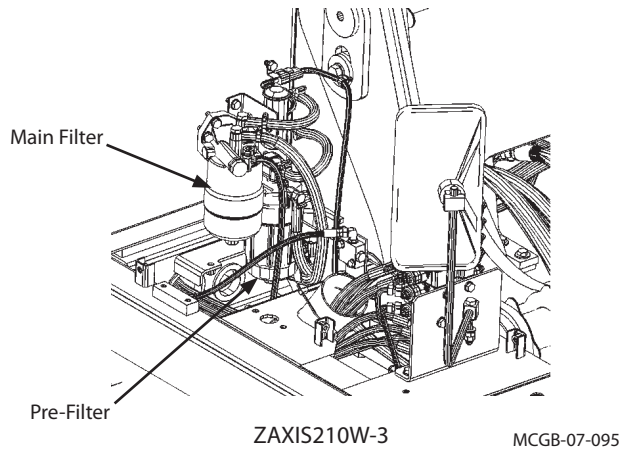
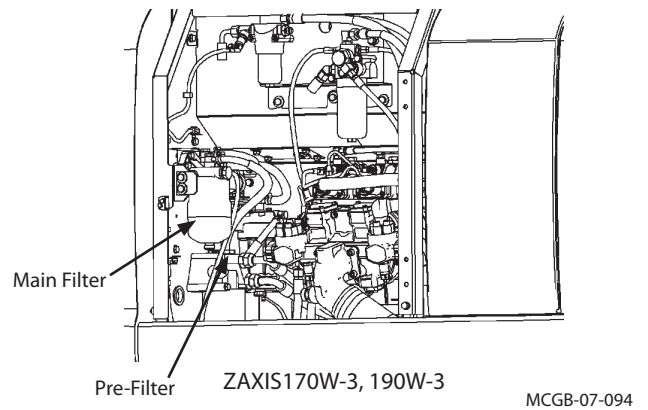
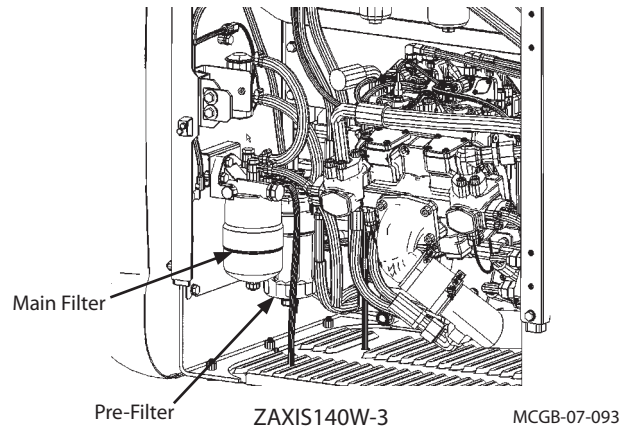

## MAINTENANCE

### I. COOLING SYSTEM

#### Coolant

Use fresh water or normal tap water as a coolant. Don't use strong acid or alkaline water. Use the coolant with genuine Hitachi Long-Life Coolant (LLC) mixed by 30 to 50 %.

If the air temperature is expected to fall below 0°C (32°F), fill the cooling system with an genuine Hitachi Long-Life Coolant (LLC) and soft water mix. As a general rule, the ratio of LLC should range between 30% and 50% as shown in the table below. If the ratio is below 30%, the system may develop rust, and if it is above 50%, the engine may overheat.

LLC Mixing Table

Air temperature	Mixing ratio	ZAXIS140W-3		ZAXIS170W-3, 190W-3		ZAXIS210W-3	
		LLC	Soft water	LLC	Soft water	LLC	Soft water
°C	%	liters	liters	liters	liters	liters	liters
-1	30	5.8	13.4	7.3	16.9	7.8	18.2
-4	30	5.8	13.4	7.3	16.9	7.8	18.2
-7	30	5.8	13.4	7.3	16.9	7.8	18.2
-11	30	5.8	13.4	7.3	16.9	7.8	18.2
-15	35	6.7	12.5	8.5	15.7	9.1	16.9
-20	40	7.7	11.5	9.7	14.5	10.4	15.6
-25	45	8.7	10.5	10.9	13.3	11.7	14.3
-30	50	9.6	9.9	12.1	12.1	13.0	13.0



#### CAUTION:

- Antifreeze is poisonous; if ingested, it can cause serious injury or death. Induce vomiting and get emergency medical attention immediately.
- When storing antifreeze, be sure to keep it in a clearly marked container with a tight lid. Always keep antifreeze out of the reach of children.
- If antifreeze is accidentally splashed into eyes, flush with water for 10 to 15 minutes and get emergency medical attention.
- When storing or disposing of antifreeze, be sure to comply with all local regulations.

# MAINTENANCE

## K. MISCELLANEOUS

### 1 Check Bucket Teeth --- daily

#### Check the bucket teeth for wear and looseness

Replace teeth (1) if tooth wear exceeds the designated service limit shown below.

Dimension A in mm (in)

Model	New	Limit of Use
ZAXIS140W-3, 170W-3	166 (6.3)	85 (3.4)
ZAXIS190W-3, 210W-3	200 (7.9)	95 (3.7)

#### Replacing procedure

**CAUTION:** Guard against injury from flying pieces of metal. Wear goggles or safety glasses, and safety equipment appropriate to the job.

1. Use hammer (2) and drift (3) to drive out locking pin (5). Be careful not to damage rubber pin lock (4) while removing locking pin (5).
2. Remove tooth (1). Inspect locking pin (5) and rubber pin lock (4) for damage, replace if necessary. Short locking pins and damaged rubber pin locks must be replaced with new ones.

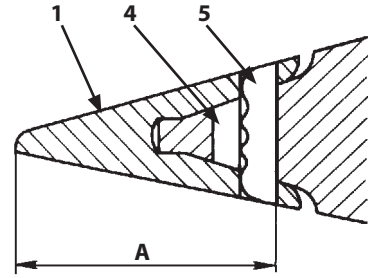

M104-07-056

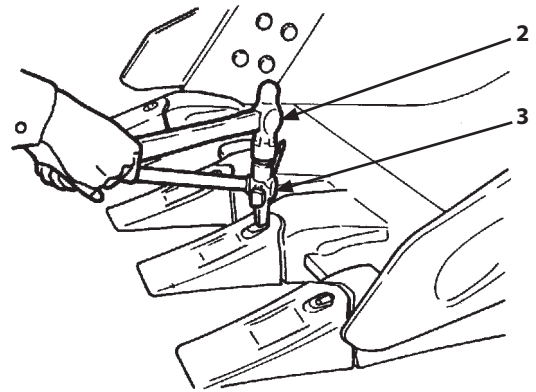

M104-07-116

**RIGHT**

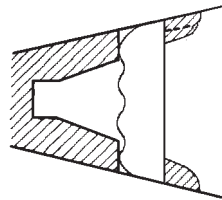

**WRONG**

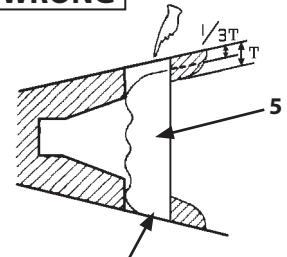

Flush one end of the locking pin to evaluate. In this instance, the locking pin is too short.

M104-07-118

M104-07-058

**WRONG**      **WRONG**

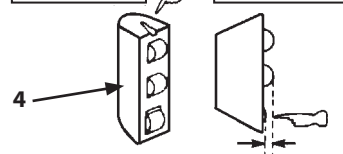

M104-07-059

## MAINTENANCE

### Adjust Compressor Belt Tension

Visually check the belt for wear. Replace if necessary. Check compressor belt tension by depressing the midpoint between compressor pulley and crank pulley with the thumb. Deflection must be ZX140W-3: 8 to 12 mm, ZX170W-3, 190W-3, 210W-3: 5 to 6 mm with a depressing force of approximately 100 N (10 kgf, 22 lbf).

If tension is not within specifications, loosen bolt (1). Move the tension pulley by bolt (2) until tension is correct. Tighten bolt (1).

 **NOTE:** When a new belt is installed, be sure to re-adjust the tension after operating the engine for 3 to 5 minutes at slow idle speed to be sure that the new belt is seated correctly.

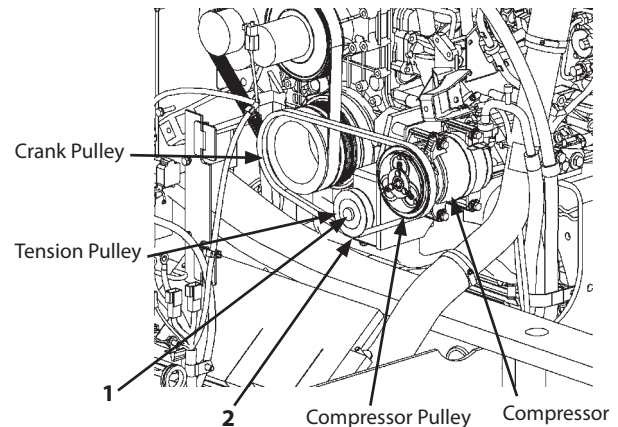

MCGB-07-066

### 9 Clean Cab Floor --- as necessary

**IMPORTANT:** When cleaning the cab floor with tap water, spray the floor only. Take care not to splash the surrounding area. Don't increase water spray speed by restricting the hose end, and don't use high pressure steam for cleaning. Be sure to completely remove any moisture from the surrounding area.

1. Park the machine on solid and level surface. Lower the bucket to the ground. Before cleaning, stop the engine.
2. Sweep the cab floor clean using a brush, and brush dust from the cab floor while spraying water.
3. When cleaning the floor mat, sweep dust (water) along the grooves on the floor mat.
4. When cleaning after removing the floor mat, sweep dust (water) through two cleaning holes (3).

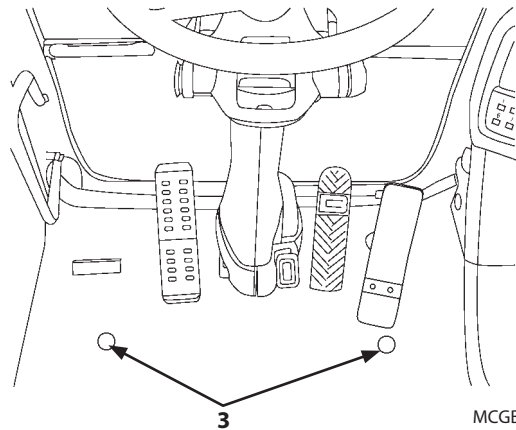

MCGB-07-067

# MAINTENANCE

12. Retighten the cab mounting nuts.

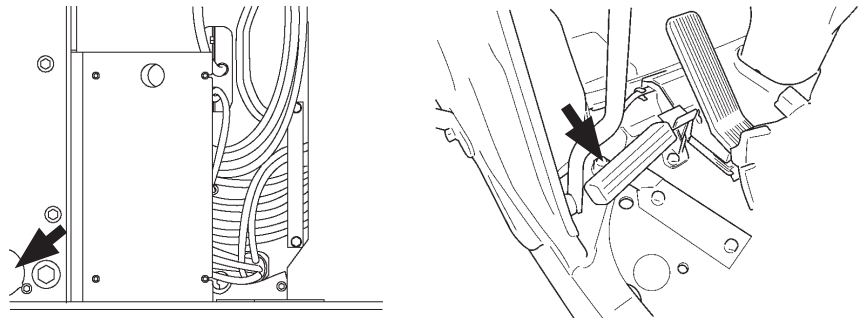

M1U4-07-021

MCBB-07-037

13. Retighten the swing bearing mounting bolts to the upperstructure.

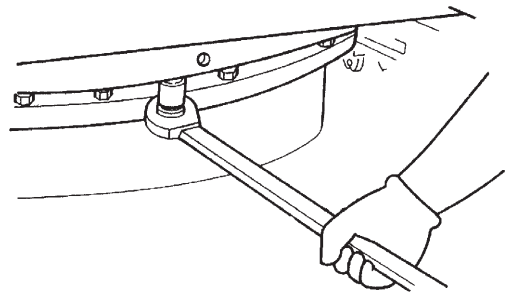

MCBB-07-041

Retighten the swing bearing mounting bolts to the chassis.

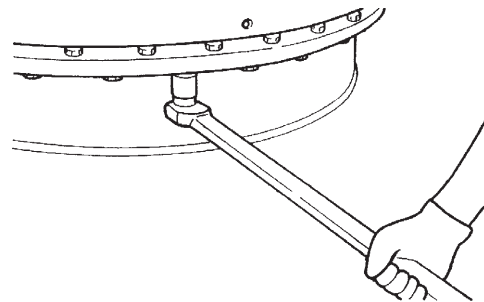

MCBB-07-042

14. Retighten center joint lock mounting bolts.

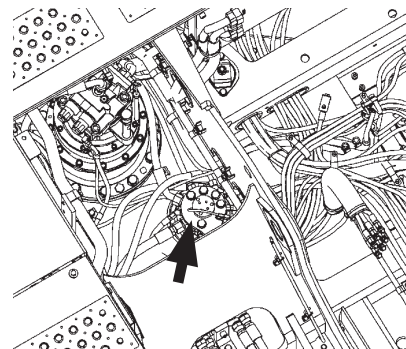

MCGB-07-063

15. Retighten transmission mounting bolts.(ZAXIS140W-3)

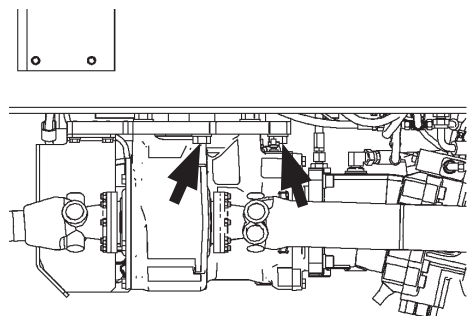

MCGB-07-086

## TROUBLESHOOTING

### 5. Hydraulic System

After the machine has been kept stowed for a long time, air in the oil may be separated and accumulate in the upper section in the cylinder, causing slow response time in operation or reducing cylinder power. In case these symptoms appear, repeatedly operate all actuators several times.

Problem	Cause	Solution
<b>All actuators of front attachment, swing, and travel will not operate. (Hydraulic pump noise level increased.)</b>	Faulty hydraulic pump Low hydraulic oil level Broken suction pipe and/or hose	* Repair and replace Refill. * Repair and replace
<b>All actuators of front attachment, swing, and travel will not operate. (Hydraulic pump noise level unchanged.)</b>	Faulty pilot pump Faulty solenoid valve Pilot control shut-off lever is in the LOCK position Front attachment pilot/blade/outrigger switch is OFF position	* Replace * Replace Move to the UNLOCK position. Place front attachment pilot/blade/outrigger switch to ON position.
<b>All actuators are weak in power.</b>	Reduced pump performance due to wear in hydraulic pump Reduced set pressure of main relief valve in control valve Low hydraulic oil level Clogged suction strainer in hydraulic oil tank Drawn air from suction side	* Replace  * Adjust  Refill Clean  Retighten
<b>Inoperable or weak in power only when one control lever is operated.</b>	Faulty relief valve in control valve Broken pipe and/or hose Loose pipe line joint Broken O-ring at pipe line joint Faulty hydraulic pump Faulty pilot valve Faulty pilot pipe line Faulty solenoid valve of pilot line	* Repair and replace * Repair and replace Retighten * Replace * Repair and replace * Replace * Repair and replace * Repair and replace
<b>Only one movement is inoperable.</b>	Broken control valve spool Seized foreign matter in valve spool Broken pipe and/or hose Loose pipe line joint Broken O-ring at pipe line joint Broken actuator Faulty pilot valve Faulty pilot pipe line Faulty solenoid valve of pilot line	* Replace * Repair and replace * Repair and replace Retighten * Replace * Repair and replace * Replace * Repair and replace * Repair and replace
<b>Only one cylinder is inoperable.</b>	Broken oil seal in cylinder Oil leak due to broken cylinder rod. Faulty pilot valve Faulty pilot pipe line Faulty solenoid valve of pilot line	* Repair and replace * Repair and replace * Replace * Repair and replace * Repair and replace

## SPECIFICATIONS

### Specifications

#### ZAXIS140W-3 (FRONT OUTRIGGER REAR BLADE)

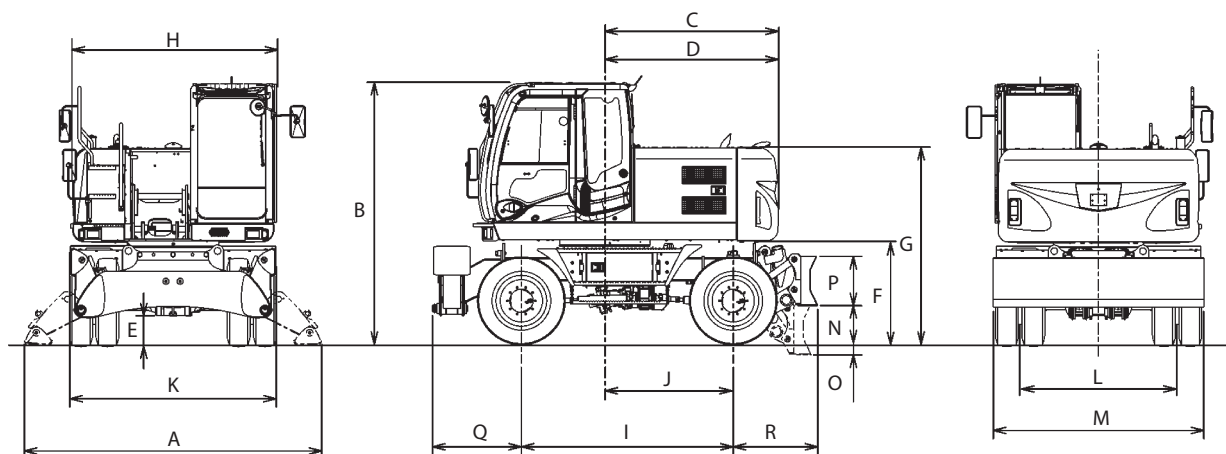

MCGB-12-004

Type of Front-End Attachment		Monoblock boom
Type of Arm	–	2.52m (8 ft 3 in)
Bucket Capacity (Heaped)	m <sup>3</sup> (yd <sup>3</sup> )	PCSA 0.50m <sup>3</sup> (0.65yd <sup>3</sup> ), CECE 0.45m <sup>3</sup>
Operating Weight	kg (lb)	15700 (34600)
Basic Machine Weight	kg (lb)	13500 (29800)
Engine		ISUZU AI-4JJ1X
Engine Power	SAE J1349 net	90.2 kW/2200 min <sup>-1</sup> (123 PS/2200 rpm)
	ISO 9249 net	
	EEC 80/1269 net	
A: Overall Width (Excluding Rearview Mirrors)	mm (ft-in)	2530 (8' 4")
B: Cab Height	mm (ft-in)	3130 (10' 3")
C: Rear End Swing Radius	mm (ft-in)	2120 (7' 0")
D: Rear End Length	mm (ft-in)	2120 (7' 0")
E: Minimum Ground Clearance	mm (ft-in)	350 (1' 2")
F: Counterweight Clearance	mm (ft-in)	1215 (4' 0")
G: Engine Cover Height	mm (ft-in)	2360 (7' 9")
H: Overall Width of Upperstructure	mm (ft-in)	2450 (8' 1")
I: Wheelbase	mm (ft-in)	2550 (8' 4")
J: Swing-center to Rear Axle	mm (ft-in)	1000 (3' 3")
K: Front Wheel Tread	mm (ft-in)	1875 (6' 2")
L: Rear Wheel Tread	mm (ft-in)	1875 (6' 2")
M: Outrigger Spread	mm (ft-in)	3380 (11' 1")
N: Max. Raising Height	mm (ft-in)	445 (1' 6")
O: Max. Digging Depth	mm (ft-in)	145 (6")
P: Blade Height	mm (ft-in)	590 (1' 11")
Q: Front Axle to Front of Chassis	mm (ft-in)	1115 (3' 8")
R: Rear Axle to Rear of Chassis	mm (ft-in)	980 (3' 3")
Tire Size	–	10.00-20 16PR
Swing Speed	min <sup>-1</sup> (rpm)	13.7
Travel Speed (fast/slow/creeper) ※	km/h(mph)	35/8.6/2.2 (21.7/5.3/1.4)
Gradeability	degree(%)	35 (70)

NOTE: ※ The specification not matching the local regulation is excluded.

## SPECIFICATIONS

### Specifications

#### ZAXIS190W-3 (Standard CHASSIS, REAR OUTRIGGER)

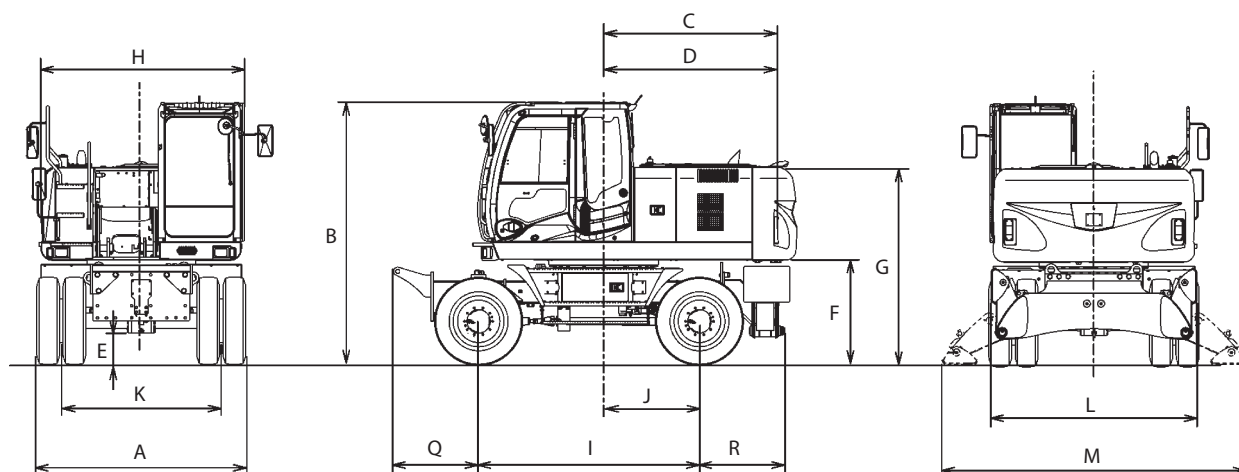

MCGB-12-016

Type of Front-End Attachment		Monoblock boom
Type of Arm	–	2.71 m (8 ft 11 in)
Bucket Capacity (Heaped)	m <sup>3</sup> (yd <sup>3</sup> )	PCSA 0.70m <sup>3</sup> (0.92yd <sup>3</sup> ), CECE 0.60m <sup>3</sup>
Operating Weight	kg (lb)	18500 (40800)
Basic Machine Weight	kg (lb)	15150 (33400)
Engine		ISUZU AI-4HK1X
Engine Power	SAE J1349 net	122 kW/2000 min <sup>-1</sup> (166 PS/2000 rpm)
	ISO 9249 net	
	EEC 80/1269 net	
A: Overall Width (Excluding Rearview Mirrors)	mm (ft-in)	2550 (8' 4")
B: Cab Height	mm (ft-in)	3130 (10' 3")
C: Rear End Swing Radius	mm (ft-in)	2320 (7' 7")
D: Rear End Length	mm (ft-in)	2320 (7' 7")
E: Minimum Ground Clearance	mm (ft-in)	350 (1' 2")
F: Counterweight Clearance	mm (ft-in)	1235 (4' 1")
G: Engine Cover Height	mm (ft-in)	2345 (7' 8")
H: Overall Width of Upperstructure	mm (ft-in)	2450 (8' 1")
I: Wheelbase	mm (ft-in)	2650 (8' 8")
J: Swing-center to Rear Axle	mm (ft-in)	1150 (3' 9")
K: Front Wheel Tread	mm (ft-in)	1945 (6' 5")
L: Rear Wheel Tread	mm (ft-in)	1945 (6' 5")
M: Outrigger Spread	mm (ft-in)	3440 (11' 3")
N: Max. Raising Height	mm (ft-in)	–
O: Max. Digging Depth	mm (ft-in)	–
P: Blade Height	mm (ft-in)	–
Q: Front Axle to Front of Chassis	mm (ft-in)	975 (3' 2")
R: Rear Axle to Rear of Chassis	mm (ft-in)	1085 (3' 7")
Tire Size	–	10.00-20 16PR
Swing Speed	min <sup>-1</sup> (rpm)	12.2
Travel Speed (fast/slow/creeper) ※	km/h(mph)	35/8.6/2.6 (21.7/5.3/1.6)
Gradeability	degree(%)	34 (67)

NOTE: ※ The specification not matching the local regulation is excluded.

# SPECIFICATIONS

## WORKING RANGES

### ZAXIS210W-3 MONOBLOCK BOOM

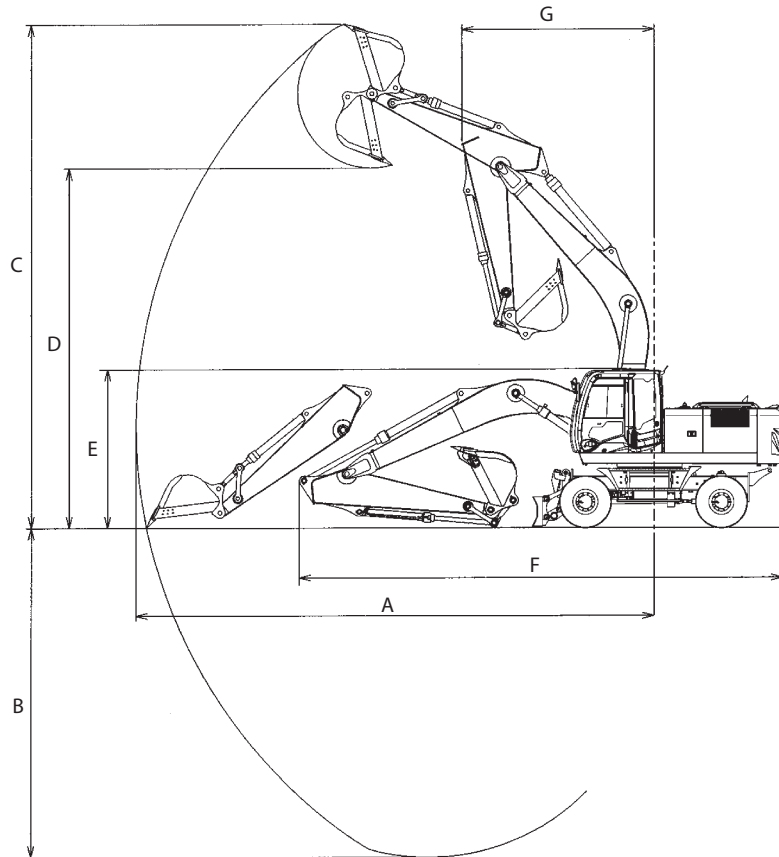

MCGB-12-027

Type of Front-End Attachment Category	Monoblock Boom		
	2.03 m (6 ft 8 in) Arm	2.42 m (7 ft 11 in) Arm	2.91 m (9 ft 7 in) Arm
Item	Backhoe	Backhoe	Backhoe
A: Maximum Digging Reach	mm (ft-in) 9470 (31' 1")	9670 (31' 9")	10170 (33' 4")
B: Maximum Digging Depth	mm (ft-in) 5410 (17' 9")	5800 (19' 0")	6290 (20' 8")
C: Maximum Cutting Height	mm (ft-in) 10020 (32' 11")	9840 (32' 3")	10190 (33' 5")
D: Maximum Dumping Height	mm (ft-in) 7110 (23' 4")	7000 (23' 0")	7350 (24' 1")
E: Transport Height	mm (ft-in) 3220 (10' 7")	3230 (10' 7")	3170 (10' 5")
F: Overall Transport Length			
Rear BL.	mm (ft-in) * 9145 (30' 0")	* 9155 (30' 0")	* 9005 (29' 7")
Rear O/R.	mm (ft-in) * 9145 (30' 0")	* 9155 (30' 0")	* 9005 (29' 7")
Front BL. Rear O/R.	mm (ft-in) * 9895 (32' 6")	* 9905 (32' 6")	* 9755 (32' 0")
Front O/R. Rear BL.	mm (ft-in) * 9915 (32' 6")	* 9925 (32' 7")	* 9775 (32' 1")
Front O/R. Rear O/R.	mm (ft-in) * 9915 (32' 6")	* 9925 (32' 7")	* 9775 (32' 1")
G: Minimum Swing Radius	mm (ft-in) 3650 (12' 0")	3520 (11' 7")	3430 (11' 3")

NOTE: \* Transport the machine with the rear side facing forward.

CLICK HERE TO **DOWNLOAD** THE COMPLETE MANUAL

- Thank you very much for reading the preview of the manual.
- You can download the complete manual from: [www.heydownloads.com](http://www.heydownloads.com) by clicking the link below



- Please note: If there is no response to CLICKING the link, please download this PDF first and then click on it.

CLICK HERE TO **DOWNLOAD** THE COMPLETE MANUAL