

# Operator's Manual

# **ZAXIS**

## **140W-3**

## **170W-3**

## **190W-3**

## **210W-3**

# **Wheeled Excavator**

Serial No.

ZX140W-3 002001 and up

ZX170W-3 003001 and up

ZX190W-3 002001 and up

ZX210W-3 002001 and up

CLICK HERE TO **DOWNLOAD** THE COMPLETE MANUAL

- Thank you very much for reading the preview of the manual.
- You can download the complete manual from: [www.heydownloads.com](http://www.heydownloads.com) by clicking the link below



- Please note: If there is no response to CLICKING the link, please download this PDF first and then click on it.

CLICK HERE TO **DOWNLOAD** THE COMPLETE MANUAL

# CONTENTS

## TRANSPORTING

Transporting by Road .....	6-1
Loading/Unloading on a Trailer .....	6-2
Transporting.....	6-4
Unloading .....	6-5
Towing Machine .....	6-6

## MAINTENANCE

Correct Maintenance and Inspection Procedures .....	7-1
Check the Hour Meter Regularly.....	7-2
Use Correct Fuels and Lubricants .....	7-2
Layout.....	7-3
Maintenance Guide Table.....	7-4
Prepare Machine for Maintenance.....	7-6
Hood and Access Covers.....	7-7
Periodic Replacement of Parts.....	7-8
Maintenance Guide .....	7-9
A. Greasing.....	7-15
Front Joint Pins.....	7-15
Swing Bearing.....	7-18
Swing Internal Gear .....	7-19
Front Axle .....	7-20
Propel Shaft (Front and Rear) .....	7-21
Equalizer Pin .....	7-22
B. Engine.....	7-23
Engine Oil Level.....	7-23
Change Engine Oil .....	7-24
Replace Engine Oil Filter .....	7-24
C. Transmission.....	7-26
Pump Transmission.....	7-26
Swing Reduction Gear.....	7-27
Transmission Gear Oil .....	7-28
Front Axle .....	7-29
Rear Axle.....	7-30
Front and Rear Hub Reduction Devices .....	7-31
D. Brake (Traveling) .....	7-32
Check Brake Accumulator .....	7-33
Check Wear on Brake Lining .....	7-34
E. Tire .....	7-35
Tire Inspection and Replacement Procedure .....	7-36
F. Hydraulic System .....	7-37
Inspection and Maintenance of	
Hydraulic Equipment .....	7-37
Breaker Maintenance .....	7-39
Check Hydraulic Oil Level.....	7-40
Change Hydraulic Oil .....	7-41
Suction Filter Cleaning .....	7-41
Replace Hydraulic Tank Oil Filter (Std. Model).....	7-45
Replace Pilot Oil Filter .....	7-47
Replace Air Breather Element .....	7-48
Check Hoses and Lines .....	7-49
Service Recommendations for Hydraulic Fittings .....	7-52
G. Fuel System.....	7-54
Drain Fuel Tank Sump .....	7-55
Check Water Separator .....	7-56

Replace Fuel Main Filter Element.....	7-60
Replace Fuel Pre-filter Element .....	7-61
Clean Fuel Solenoid Pump Strainer .....	7-62
Check Fuel Hoses.....	7-63
H. Air Cleaner.....	7-64
Clean the Air Cleaner Outer Element .....	7-64
Replace the Air Cleaner Outer and Inner Elements... ..	7-64
I. Cooling System .....	7-66
Check Coolant Level.....	7-67
Check and Adjust Fan Belt Tension .....	7-67
Change Coolant .....	7-68
Clean Radiator Interior.....	7-68
Clean Radiator, Oil Cooler Core and Inter Cooler .....	7-69
Clean Oil Cooler, Radiator and Inter	
Cooler Front Screen .....	7-69
Clean Air Conditioner Condenser.....	7-69
Clean Fuel Oil Cooler .....	7-69
Clean Air Conditioner Front Screen (Opt.) .....	7-69
J. Electrical System .....	7-70
Batteries .....	7-70
Replace Battery .....	7-73
Remove and Installing Battery .....	7-74
Replacing Fuses.....	7-74
K. Miscellaneous .....	7-76
Check Bucket Teeth.....	7-76
Change Bucket .....	7-78
Convert Bucket Connection Into Face Shovel.....	7-79
Adjust the Bucket Linkage .....	7-80
Check and Replace Seat Belt Check.....	7-81
Check Windshield Washer Fluid Level.....	7-82
Clean and Replace Air Conditioner Filter	
Clean Filter .....	7-83
Replace Filter .....	7-83
Check the Air Conditioner .....	7-85
Clean Cab Floor .....	7-86
Retighten Cylinder Head Bolt.....	7-87
Inspect and Adjust Valve Clearance.....	7-87
Measure Engine Compression Pressure .....	7-87
Check Starter and Alternator.....	7-87
Check Tightening Torque of Bolts and Nuts .....	7-88

## MAINTENANCE UNDER SPECIAL ENVIRONMENTAL CONDITIONS

Maintenance Under Special Environmental Conditions..	9-1
--	-----

## STORAGE

Storing the Machine.....	10-1
Removing the Machine from Storage.....	10-2

## TROUBLESHOOTING

Troubleshooting .....	11-1
Engine.....	11-1
Engine Auxiliaries .....	11-1
Engine is Hard to Start .....	11-2
Control Lever.....	11-3

## SAFETY

### INVESTIGATE JOB SITE BEFOREHAND

- When working at the edge of an excavation or on a road shoulder, the machine could tip over, possibly resulting in serious injury or death.
- Investigate the configuration and ground conditions of the job site beforehand to prevent the machine from falling and to prevent the ground, stockpiles, or banks from collapsing.
- Make a work plan. Use machines appropriate to the work and job site.
- Reinforce ground, edges, and road shoulders as necessary. Keep the machine well back from the edges of excavations and road shoulders.
- When working on an incline or on a road shoulder, employ a signal person as required.
- Confirm that your machine is equipped a FOPS cab before working in areas where the possibility of falling stones or debris exist.
- When the footing is weak, reinforce the ground before starting work.
- When working on frozen ground, be extremely alert. As ambient temperatures rise, footing becomes loose and slippery.
- Beware the possibility of fire when operating the machine near flammable objects such as dry grass.
- Make sure the work site has sufficient strength to firmly support the machine.

When working close to an excavation or at road shoulders, operate the machine with the tracks positioned perpendicular to the cliff face with travel motors at the rear, so that the machine can more easily evacuate if the cliff face collapses.

- If working on the bottom of a cliff or a high bank is required, be sure to investigate the area first and confirm that no danger of the cliff or bank collapsing exists. If any possibility of cliff or bank collapsing exists, do not work on the area.
- Soft ground may collapse when operating the machine on it, possibly causing the machine to tip over. When working on soft ground is required, be sure to reinforce the ground first using large pieces of steel plates strong and firm enough to easily support the machine.
- Note that there is always a possibility of machine tipping over when working on rough terrain or on slopes. Prevent machine tipping over from occurring. When operating on rough terrain or on slopes:
  - Reduce the engine speed.
  - Select slow travel speed mode.
  - Operate the machine slowly and be cautious with machine movements.



SA-085

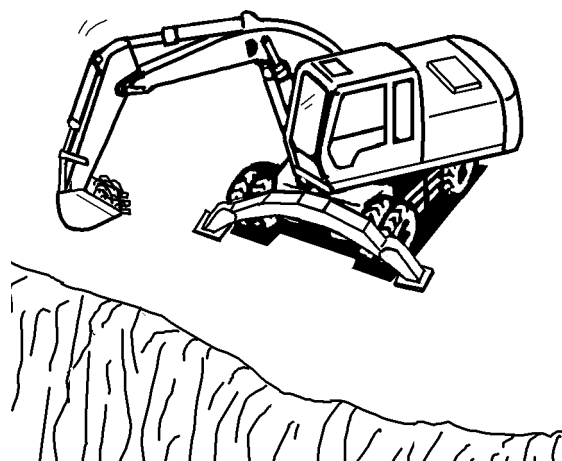

M202-05-015

## SAFETY

### PRACTICE SAFE MAINTENANCE

To avoid accidents:

- Understand service procedures before starting work.
- Keep the work area clean and dry.
- Do not spray water or steam inside cab.
- Never lubricate or service the machine while it is moving.
- Keep hands, feet and clothing away from power-driven parts.

Before servicing the machine:

1. Park the machine on a level surface.
2. Lower the bucket to the ground.
3. Turn the auto-idle switch off.
4. Run the engine at slow idle speed without load for 5 minutes.
5. Turn the key switch to OFF to stop engine.
6. Relieve the pressure in the hydraulic system by moving the control levers several times.
7. Remove the key from the switch.
8. Attach a "Do Not Operate" tag on the control lever.
9. Pull the pilot control shut-off lever to the LOCK position.
10. Allow the engine to cool.

- If a maintenance procedure must be performed with the engine running, do not leave the machine unattended.
- If the machine must be raised, maintain a 90 to 100° angle between the boom and arm. Securely support any machine elements that must be raised for service work.
- Inspect certain parts periodically and repair or replace as necessary. Refer to the section discussing that part in the "MAINTENANCE" chapter of this manual.
- Keep all parts in good condition and properly installed.
- Fix damage immediately. Replace worn or broken parts. Remove any buildup of grease, oil, or debris.
- When cleaning parts, always use nonflammable detergent oil. Never use highly flammable oil such as fuel oil and gasoline to clean parts or surfaces.
- Disconnect battery ground cable (–) before making adjustments to electrical systems or before performing welding on the machine.



SA-028



SA-527

500-E02C-0520

## SAFETY SIGNS/Oceania Model Only

All safety signs and their locations affixed on the machine are illustrated in this group. Make sure of the contents described in the safety signs through reading actual ones affixed on the machine to ensure safe machine operation. Always keep the safety signs clean. In case a safety sign is broken or lost, immediately, obtain a new replacement and affix it again in position on the machine. Use the part No. indicated under the right corner of each safety sign illustration when placing an order of it to the Hitachi dealer.

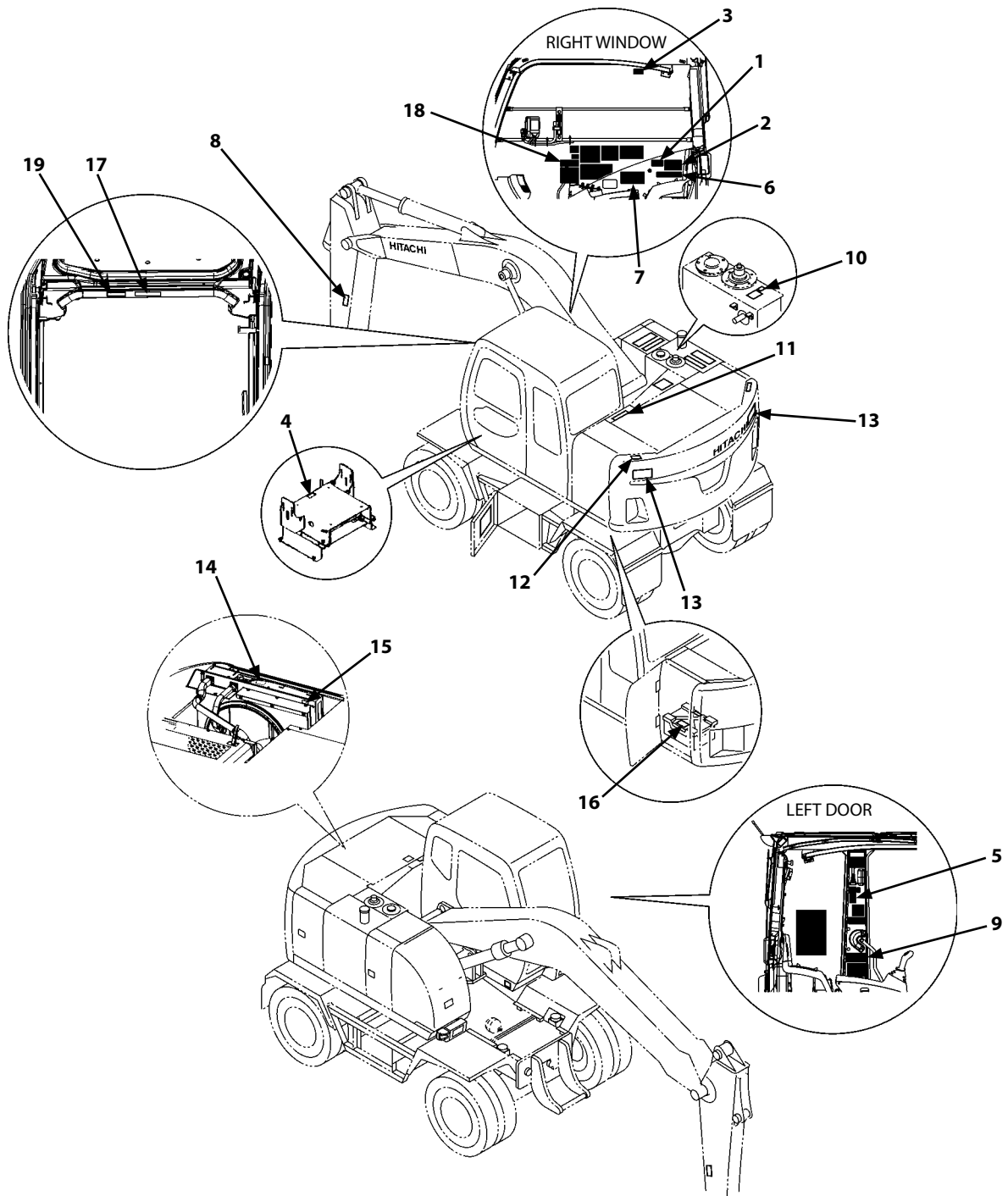

## SAFETY SIGNS/Asia/Middle and Near East Model Only

9.

Sign indicates a hazard of being hit by the working device of the machine.

Keep away from machine during operation.



SS3089581

10.

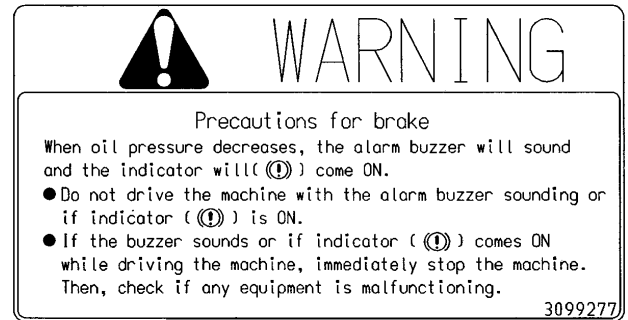

SS3099277

## OPERATOR'S STATION

### BRAKE PEDAL

**⚠ WARNING:** Be aware of the following points.

- When returning brake pedal (1), don't quickly release your foot from the pedal. By failure to do so, all hydraulic oil in the circuit is discharged, possibly causing the machine to start moving. Use extra care when operating the brake.
- If brake pedal (1) is repeatedly stepped on/off more than necessary, the hydraulic oil will be temporarily discharged from the accumulator, causing the oil pressure to decrease. Therefore, carefully operate the brake as brake performance may be reduced.

A full-hydraulic brake system is employed on this machine so that powerful braking force is applied by lightly touching brake pedal (1). Accordingly, only use sudden brake operation in case of emergency.

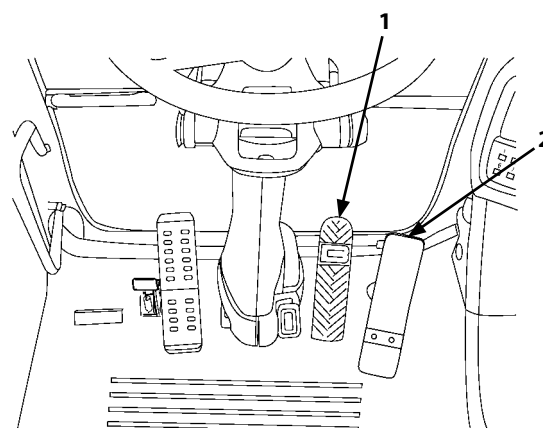

MCGB-01-004

1. Operate the brake pedal in the following procedures to smoothly stop the machine:

- 1.1 Slowly release brake pedal (2) when the machine approaches 25 to 35 m before the target area to stop.
- 1.2 Lightly depress brake pedal (1) when the machine approaches 5 to 6 m before the target area to stop.
- 1.3 Slightly release brake pedal (1) just before the machine reaches the target area and re-depress the pedal to completely stop the machine.

2. In case the brake becomes inoperable, turn brake switch (3) to the P (parking brake) position to stop the machine. However, only use this operation in case of emergency. After using this operation, sufficiently check that the parking brake has no failure.

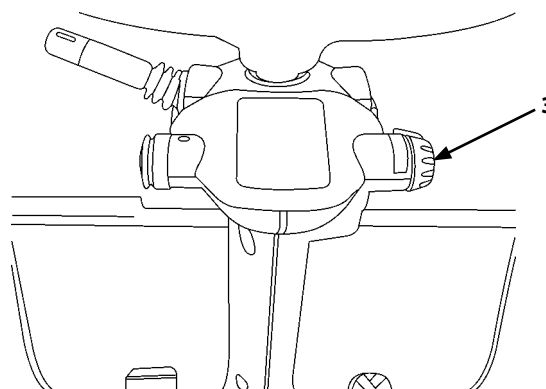

MCGB-01-003

# OPERATOR'S STATION

## Engine Control Dial

Turn engine control dial (1) to adjust the engine speed.

Clockwise : Fast idle

Counterclockwise : Slow idle

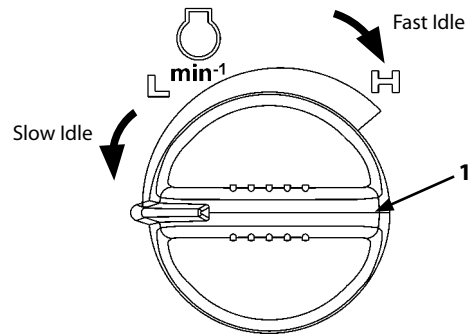

MTU1-01-033

## Travel Mode Switch

Select travel modes, FAST or SLOW by turning travel mode switch (1) to either position.



Mark (Fast Speed Mode)





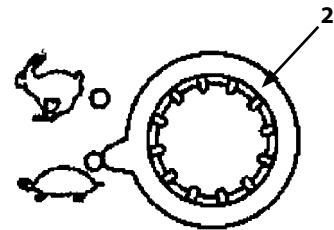

Mark (Slow Speed Mode)



MCJB-01-005

When travel mode switch (2) is shifted to the desired mode position, corresponding travel mode indicator (3) comes ON.

**IMPORTANT:** Shifting the travel mode  ↔  can be achieved while the machine is traveling. During traveling, when the Fast travel mode  is shifting down to the SLOW mode , the transmission is shifted after the actual travel speed becomes slower to some extent.

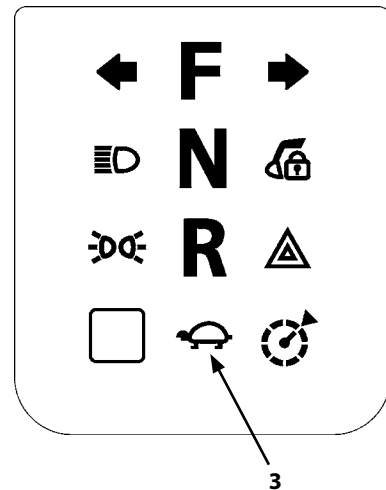

TCJB-01-02-004

# OPERATOR'S STATION

## RIGHT/LEFT CONTROL LEVERS

### [Domestic or Asia/Middle and Near East/Oceania Models]

Various kinds of switches are provided on the top of each control lever.

- 1- Attachment switch (Assist control)
- 2- Power digging (Only ZX210W-3 Models)
- 3- Attachment switch (Assist control)
- 4- Auxiliary
- 5- Horn
- 6- Auxiliary

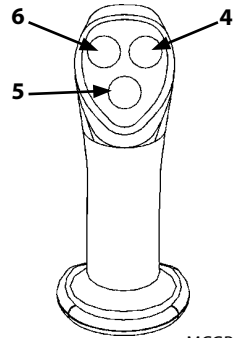

MCGB-01-034

Left Control Lever

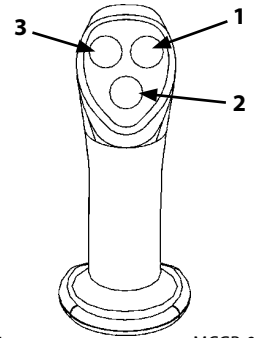

MCGB-01-034

Right Control Lever

### [European Models]

- 1- Auxiliary
- 2- Power digging (Only ZX210W-3)
- 3- Attachment analog switch (Assist control)
- 4- Auxiliary (Analog switch)
- 5- Auxiliary pedal selection switch (Attachment)
- 6- Auxiliary pedal selection switch (Positioning, 2-piece boom spec only)
- 7- Forward/reverse travel switch
- 8- Horn

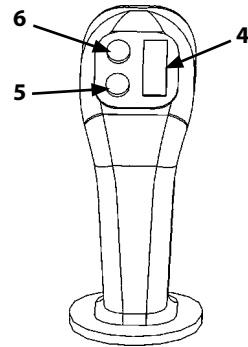

MCGB-01-029

Left Control Lever for European Models

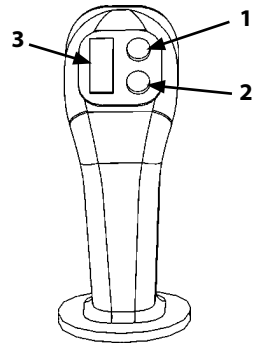

MCGB-01-030

Right Control Lever for European Models

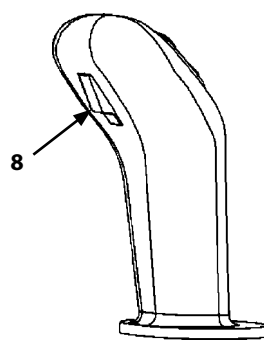

MCGB-01-031

Back Face of the Left Control Lever for European Models

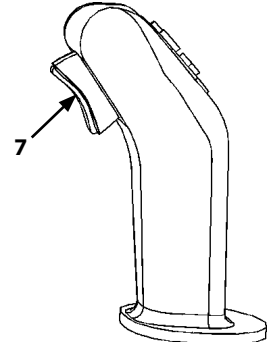

MCGB-01-032

Back Face of the Right Control Lever for European Models

## OPERATOR'S STATION

### Brake oil pressure gauge (33)

Indicates the oil pressure in the brake oil pressure circuit.

### Travel speed meter (34)

Indicates the machine travel speed.

 **NOTE:** While setting other functions on the monitor unit, when the machine travels forward, the basic screen is displayed.

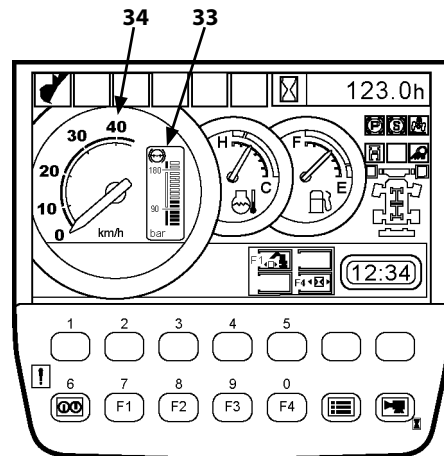

MCGB-01-041

### Tachometer (35)

Indicates the engine speed.

 **NOTE:** According to setting operation, either travel speed meter (34) or tachometer (35) is displayed.

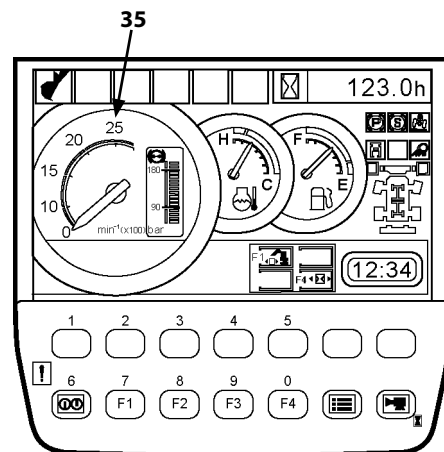

MCGB-01-045

## OPERATOR'S STATION

### Corrective measures to be taken when a wrong password is input:

1. If a wrong password is input, the message "Password is incorrect" is displayed by pressing the determination key.

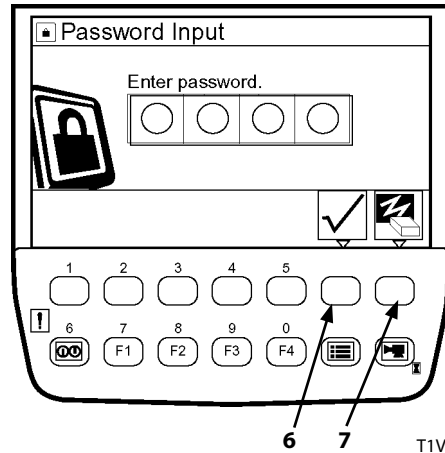

T1V5-05-01-002

2. Press key (7) to return to password input screen (4).

 **NOTE:** When performing password input operation again, press key (7) to erase the entered password.

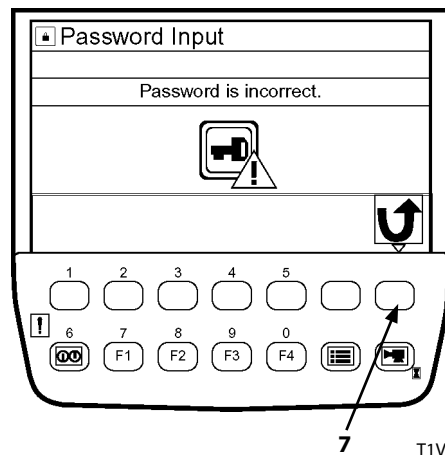

T1V5-05-01-004

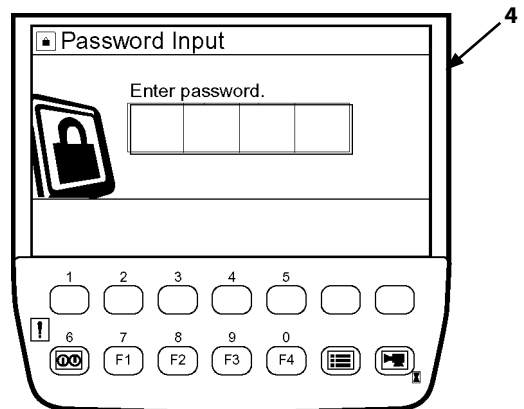

T1V5-05-01-093

# OPERATOR'S STATION

## Attachment Specification Screen

### Breaker 1

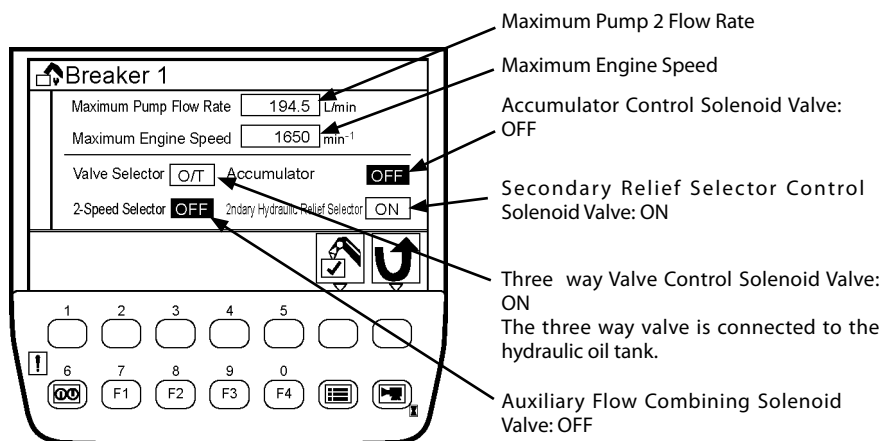

TCJB-05-02-081

### Breaker 2

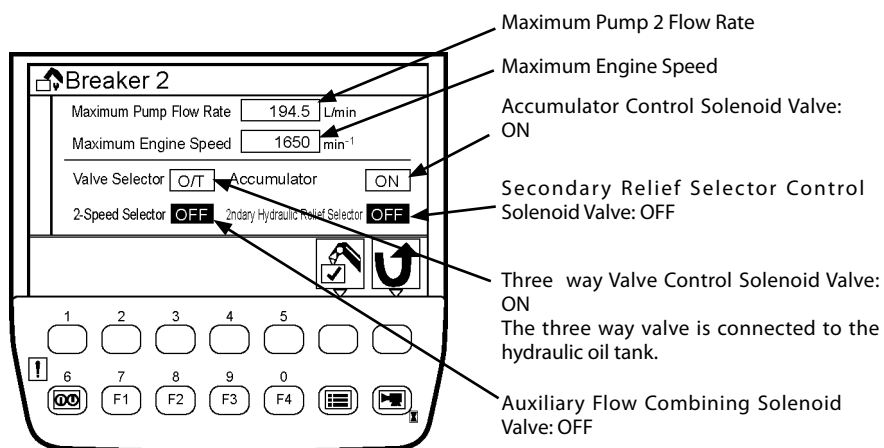

TCJB-05-02-082

# OPERATOR'S STATION

- When two or more ON-set information are present:

- When the key switch is turned ON, the starting screen and basic screen (1) are displayed in series. When the machine operation hours reach the ON-set maintenance item hours, the notice of displaying the maintenance information screen is shown at the top of the basic screen for three seconds. Then, the basic screen is automatically shifted to maintenance required item screen (2).

**NOTE:** In case a machine is set to display the basic screen only after the password is entered, input the password first. Then, press the determination key to display the basic screen.

- When data resetting is required, select the maintenance item by operating keys (5 and 6) on maintenance required item screen (2) before maintenance required item screen (2) disappears. Press key (4) to display maintenance information screen (7) for the selected maintenance item. (Hydraulic oil is selected as an example in this section.)

**NOTE:** When key (3) is pressed on maintenance required item screen (2), basic screen (1) is displayed.

- After displaying maintenance information screen (7), press key (4). The message "Data is reset. OK?" and reset screen (8) are displayed. Press key (4). The remaining hour display becomes equal to the change interval hours. The previous change date and hour are updated to the present date and hour.

**NOTE:** When key (3) is pressed on maintenance information screen (7), maintenance required item screen (2) is displayed.

**NOTE:** When key (3) is pressed on reset screen (8), maintenance information screen (7) is displayed.

- After displaying the maintenance information screen (7) for 10 seconds, basic screen (1) is displayed.

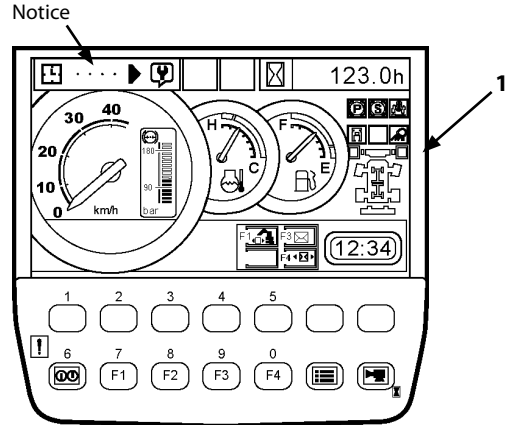

MCGB-01-052

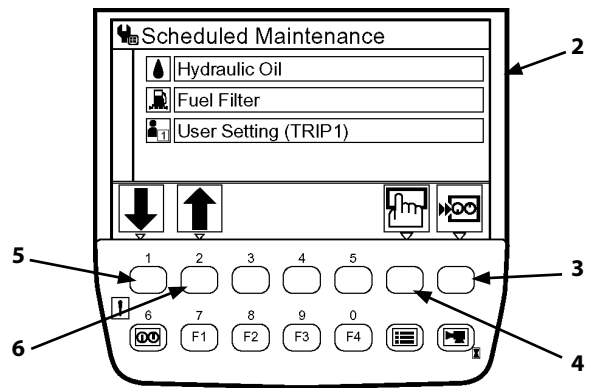

T1V5-05-01-169

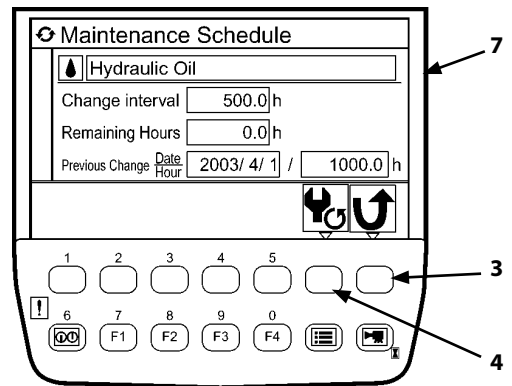

TCHB-05-02-011

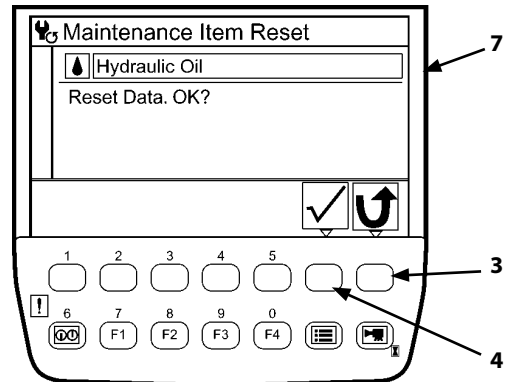

T1V5-05-01-171

## OPERATOR'S STATION

### Auto activation: OFF

Even though the forward/reverse switch is shifted to the R (reverse) position, the monitor unit image is not automatically shifted to the back monitor image.

1. After displaying basic screen (1), press menu key (2) to display main menu screen (3).

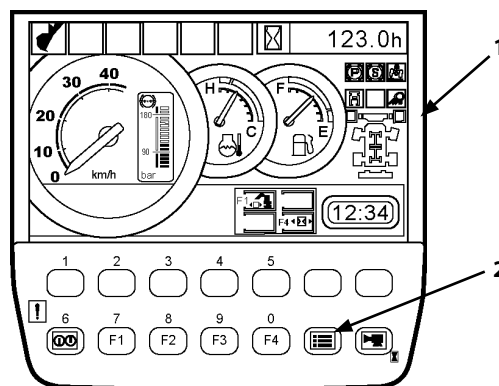

Basic Screen

MCGB-01-041

2. Select the back monitor setting (8) menu on main menu screen (3) by operating keys (4 and 5). Press key (6) to display back monitor set screen (9).

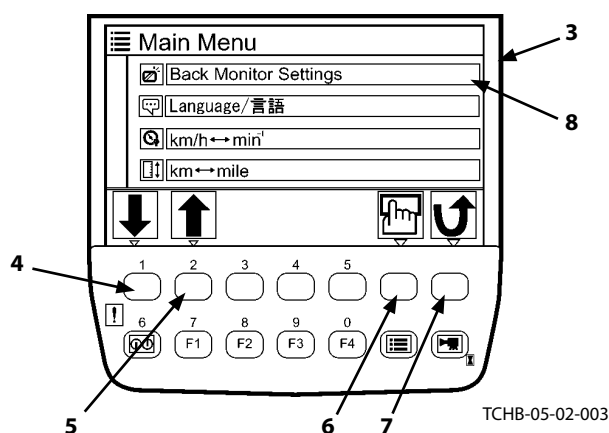

TCHB-05-02-003

3. In case the auto activation is set ON (10), the "OFF" column is displayed in yellow. Press key (6) to set the auto activation OFF.

NOTE: Press key (7) to return to the previous screen.

4. Press key (11) to return to basic screen (1).

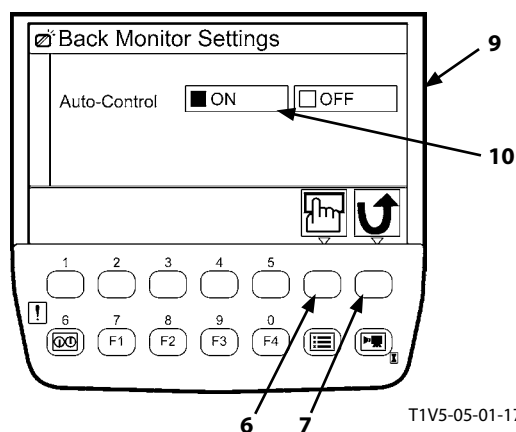

T1V5-05-01-174

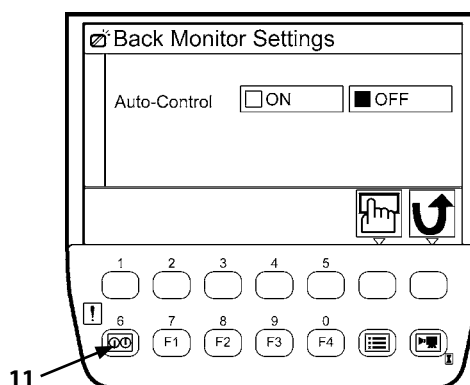





T1V5-05-01-173

## OPERATOR'S STATION

### Controller Part Name and Function

- Mode Switch (14)

Selects the air vent in the four modes as shown below. The selected air vent is displayed on the LCD.

-  : Front/Defroster Vent Mode
-  : Front/Rear/Defroster Vent Mode
-  : Front/Rear/Foot/Defroster Vent Mode
-  : Foot Vent Mode

Each time mode switch (14) is pressed, the air vent is selected in 4 stages.



- When AUTO switch (9) is selected, the blower speed, vent mode, and ventilation mode are automatically controlled in response to the set-temperature.
- Temperature Control Switch (11)

Sets the temperature in the cab. The air temperature can be set in the range of 18.0 to 32.0 °C. Temperature can be adjusted by 0.5 °C increments. The set-temperature is displayed on the LCD (7).

- FC (FULL COOL)

When the button with mark  on temperature control switch (11) is pressed after setting air temperature to 18.0 °C, air flow temperature is set to the lowest and LCD panel (7) indicates "FC".

- FH (FULL HEAT)

When the button with mark  on temperature control switch (11) is pressed after setting air temperature to 32.0 °C, air flow temperature is set to the highest and LCD panel (7) indicates "FH".

- When the AUTO indicator is ON, air temperature at the vents is automatically controlled so that the temperature in the cab is maintained at the set-temperature.
- When the AUTO indicator is OFF, air temperature at the vents is automatically maintained at the set-temperature.
- When LCD panel (7) indicates "FC", air flow-in temperature at the vent, air vent (front and rear) locations, circulation air suction port, and blower speed are maintained at the lowest cooling conditions. However, in case the circulation indicator is ON before the LCD indicates "FC", the circulation mode is maintained.

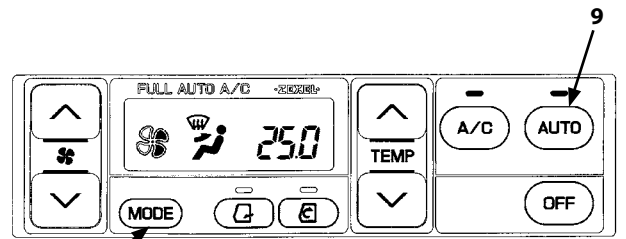

14

M178-01-074

Display when AUTO switch (9) is pressed.

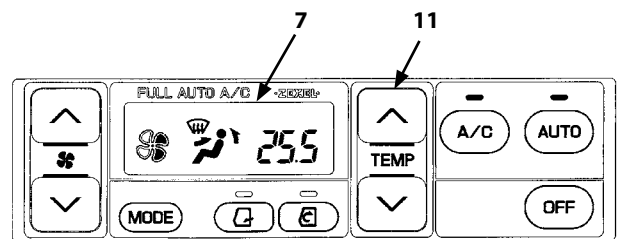

M178-01-075

Display when the  button is pressed after displaying 25.0 °C (77 °F).

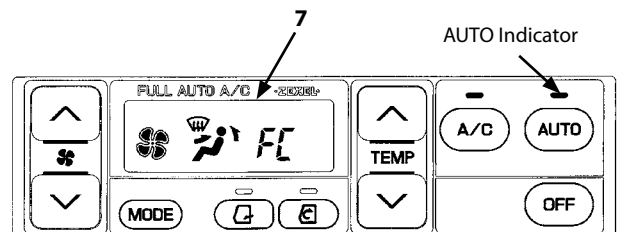

M178-01-076

Display when the LCD displays "FC" symbol.

# OPERATOR'S STATION

## AM/FM RADIO OPERATION

### Controls on the Radio

1- Power Switch/Volume Control Knob

2- Tone Adjustment Ring

3- AM/FM Switch

Each time this button is pressed, "AM" or "FM" is selected.

4- Station Presets

5- Tuning Switches

6- Display Mode Change Switch

Each time this button is pressed, the display indicates the clock or the receiving channel frequency.

7- Digital Display

8- Time Set Switches

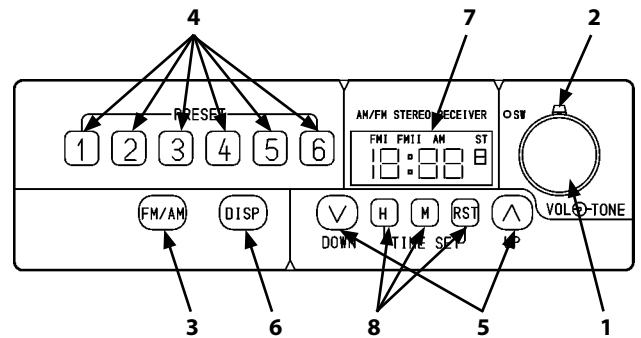

M1G6-01-026

**IMPORTANT: Refrain from listening to the radio while traveling or operating the machine. Being distracted can possibly create a hazardous situation.**

### Tuning Procedure

#### Manual Tuning Procedure

Tap (within half second intervals) one of tuning switches (5) until the desired station is detected.

Each time the tuning switch is pressed, the frequency changes at an interval.

Tap the tuning switch (^) to increase the frequency.

Tap the tuning switch (v) to decrease the frequency.

Digital display (7) will return to the setting (the clock or the frequency, whichever one is set by the display mode change switch) approximately 5 seconds after tuning switches (5) are no longer tapped or pressed.

#### Automatic Search Function

Press and hold one tuning switch (5) for more than half a second, then release. The frequency display will automatically stop as soon as the next frequency station is detected.

To search the next higher frequency station, press and hold the tuning switch (^).

To search the next lower frequency station, press and hold the tuning switch (v).

In order to deactivate the automatic search function, simply tap tuning switch (5) again.

If the receiving radio waves are weak, i. e. such as when the machine is located between high rising buildings, etc., manually select the desired station.

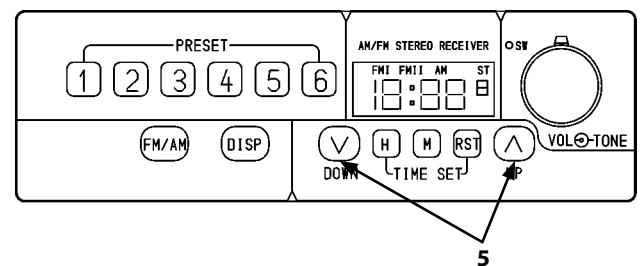

M1G6-01-026

## OPERATOR'S STATION

### ADJUSTING THE AIR-SUSPENSION SEAT (Optional)

**⚠ CAUTION:** Avoid possible injury while operating height/tilt lever (1). When pushing down height/tilt lever (1), be sure to push on the upper face of height/tilt lever (1). Do not grab it. Fingers may be pinched between lever (1) and the seat stand.

#### Seat Height and Cushion Angle Adjustment

Front and rear parts of the seat height and cushion angle are independently adjustable in the range of 60 mm (2.4 in) with 5 steps every 15 mm by operating height/tilt lever (1).

Pushing lever (1) downward:

Front part of the cushion can be raised or lowered.

Pulling lever (1) upward:

Rear part of the cushion can be raised or lowered.

#### Console and Seat Fore-aft Adjustment

Operate console and seat slide lever (2) to adjust the console and seat fore-aft position.

Seat and console fore-aft adjustment range is 120 mm with 7 steps every 20 mm.

#### Seat Fore-Aft Adjustment

Operate seat fore-aft slide lever (3) to adjust the seat fore-aft position.

Seat fore-aft adjustment range is 160 mm with 11 steps every 16 mm.

#### Suspension Adjustment

Push knob (4) to increase suspension stiffness.

Pull knob (4) to decrease suspension stiffness.

#### Backrest Adjustment

Pull backrest adjustment lever (5) to release backrest lock. Move the backrest to the desired position and release the lever to lock the backrest in position.

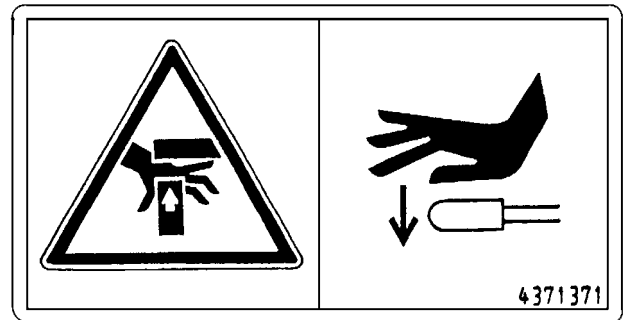

Caution: Possibility of pinched fingers

Push down with the palm.

SS-955

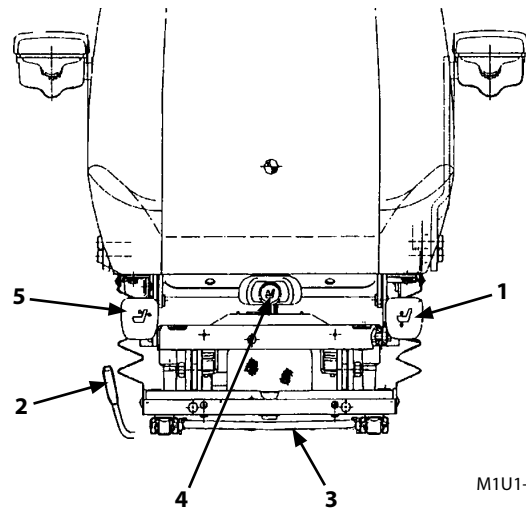

M1U1-01-014

## OPERATING THE ENGINE

10. Release key switch (2) immediately after the engine has started. It will automatically return to ON position.

 **NOTE:** In case the oil pressure in the brake accumulator is low, when the key is turned ON, the buzzer continues to sound and brake oil pressure indicator (10) comes ON. However, this is not a failure, advising that the brake does not work effectively even if the brake pedal is depressed as the oil pressure in the accumulator is low. Brake oil pressure indicator (10) will go OFF and the buzzer will stop sounding after a short time.

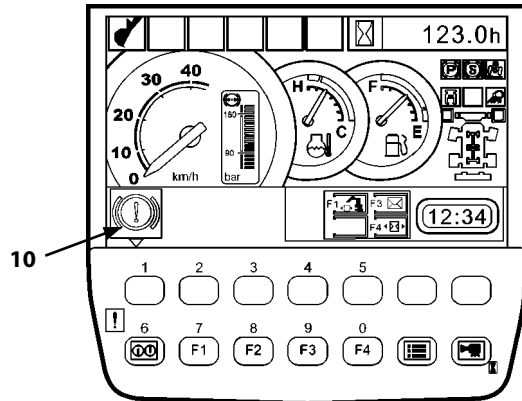

MCGB-03-005

CLICK HERE TO **DOWNLOAD** THE COMPLETE MANUAL

- Thank you very much for reading the preview of the manual.
- You can download the complete manual from: [www.heydownloads.com](http://www.heydownloads.com) by clicking the link below



- Please note: If there is no response to CLICKING the link, please download this PDF first and then click on it.



CLICK HERE TO **DOWNLOAD** THE COMPLETE MANUAL

## DRIVING THE MACHINE

### TRAVEL MODE SWITCH

**⚠ WARNING: Tipping-over accidents can cause serious personal injury. Do not change travel mode while traveling; especially, changing to the fast mode when descending slopes will create a very dangerous situation. Always stop the machine before changing the travel speed mode.**

Turn travel mode switch (1) on the switch panel to the specified position to select the travel mode (Fast/Slow).

- Fast Mode: Turn travel mode switch (1) to  mark (2) position.
- Slow Mode: Turn travel mode switch (1) to  mark (3) position.

 Mark (Fast Speed Mode)

 Mark (Slow Speed Mode)

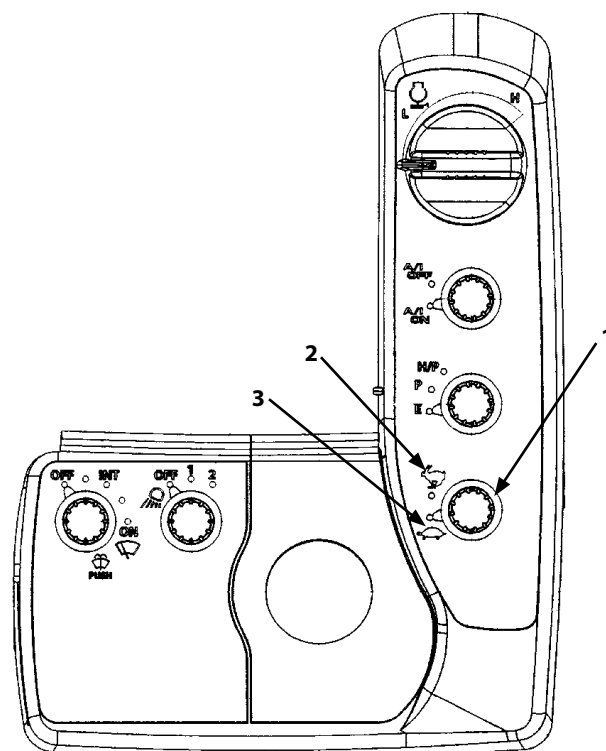

M1U1-01-015

### Starting to Travel

1. Be sure that brake oil pressure gauge needle remains within the white range.
2. Check for safety around the machine. Place the forward/reverse switch in the forward or the reverse position. Turn the brake switch OFF (traveling) to release the parking brake. Engine speed (travel idle speed) will increase at this time. Slowly step on the accelerator pedal to start traveling. Use the accelerator pedal to accelerate or decelerate the travel speed.
3. In a safe place, confirm that the brakes function properly.

**⚠ WARNING: When the upperstructure is rotated 180°, travel and steering control directions are reversed. Use extra care when traveling.**

## OPERATING THE MACHINE

### PILOT CONTROL SHUT-OFF LEVER

Pilot control shut-off lever (1) prevents misoperation of the machine from occurring if the control levers are accidentally moved when leaving the operator's seat or when entering the cab.

#### **WARNING:**

- Always pull pilot control shut-off lever (1) into the full LOCK position. The pilot control shut-off function will not be activated otherwise.
- When leaving the machine, be sure to stop the engine. Then, pull the pilot control shut-off lever up to the LOCK position.
- Always pull the pilot control shut-off lever up to the LOCK position after operation is complete or before transporting the machine.

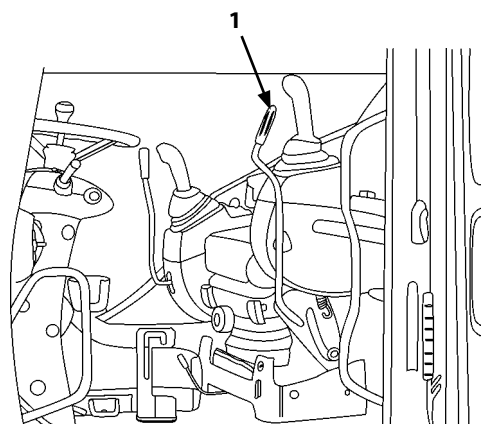

LOCK Position

MCGB-05-001

#### **Before Leaving the Machine:**

1. Park the machine on firm, level surface. Lower the bucket to the ground. Place all control levers to neutral. Turn the brake switch to the "P" (parking) position. Properly shut down the engine.
2. Pull pilot control shut-off lever (1) up to the full LOCK position.

#### **Before Starting Operation:**

1. Place pilot control shut-off lever (1) in the LOCK position before starting the engine.

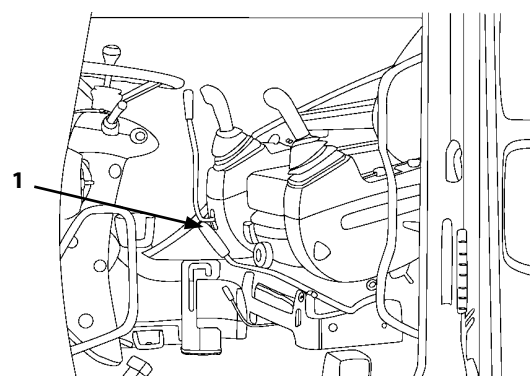

UNLOCK Position

MCGB-05-002

#### **After starting the engine:**

1. When starting operation, slowly lower pilot control shut-off lever (1) to the UNLOCK position from the LOCK position. Confirm that all control levers and pedals are in neutral and that no part of the machine is in motion.

**WARNING:** When pilot control shut-off lever (1) is lowered to the UNLOCK position, if any part of the machine (any actuator) moves with all controls in neutral, the machine is malfunctioning. Immediately pull the pilot control shut-off lever back to the LOCK position, and stop the engine. Then, consult your nearest Hitachi dealer. The travel system is operable even though pilot control shut-off lever (1) is placed in the LOCK position. When traveling, always place pilot control shut-off lever (1) in the LOCK position. Failure to do so may cause the front attachment to unexpectedly move if the control levers are moved by mistake, possibly resulting in personal injury or death.

## OPERATING THE MACHINE

---

### Engine Speed Control Mode Selection Switch

The engine speed control mode, pedal, dial, or creeper, is selected by operating engine control mode selection switch (1). Depending on machine operating conditions, select the appropriate engine control mode.

-  Pedal Mode

This mode suits normal travel operation best. Adjusting the stroke of the accelerator pedal controls the engine speed. When the pedal is stepped on, the engine speed increases. When the pedal is returned to neutral, the engine speed is reduced. After the engine speed is set to run at the slow idle speed by fully turning the engine control dial counter-clockwise before traveling the machine, when traveling is started by stepping the accelerator pedal, the engine speed increases in proportion to the pedal stroke. When the pedal is returned to neutral to temporarily stop the machine, the engine speed is reduced to the slow idle speed, decreasing fuel consumption and travel noise level.

-  Dial Mode

This mode suits traveling in the job site best. Only the engine control dial can control the engine speed irrespective of how much the accelerator pedal is stroked. The engine speed is kept constant while traveling short distance in the same job site during operation of the front attachment, no readjustment of the engine speed is required. However, the maximum travel speed is slightly slower than the pedal mode.

-  Creeper Mode

The machine can travel at very slow speed. The engine speed is controlled with the engine control dial only. Even if the engine control dial is turned fully clockwise to set the engine speed to fast idle speed and the accelerator pedal is fully stepped on, the machine can travel at very slow speed.

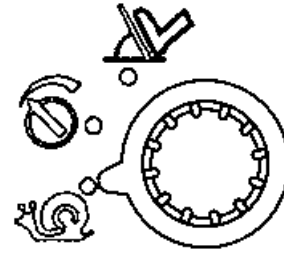

MCBB-01-024

# TRANSPORTING

## TRANSPORTING BY ROAD

When transporting the machine on public roads, be sure to first understand and follow all local regulations.

- When transporting the machine using a trailer, check the width, height, length and weight of the trailer with the machine loaded. Note that the weight and transporting dimensions will vary depending on the type of stabilizer/blade or arm to be installed on the machine. Refer to the mass (weight) shown in the specifications and take care that the trailer is not overloaded.
- Investigate beforehand the conditions of the route to be traveled, such as dimensional limits, weight limits, and traffic regulations.

**CAUTION:** The auxiliary bar attached to the rear section of the hand rail can be installed in two positions to adjust its height. Install the auxiliary bar in the transportation position when transporting the machine.

**IMPORTANT:** After transporting the machine, reinstall the auxiliary bar in the normal operation position before operating the machine.

Obtain special permission from the authorities concerned or disassemble the machine to meet the transportation dimensional limits as needed. Consult your nearest Hitachi dealer when transporting the machine by road is required.

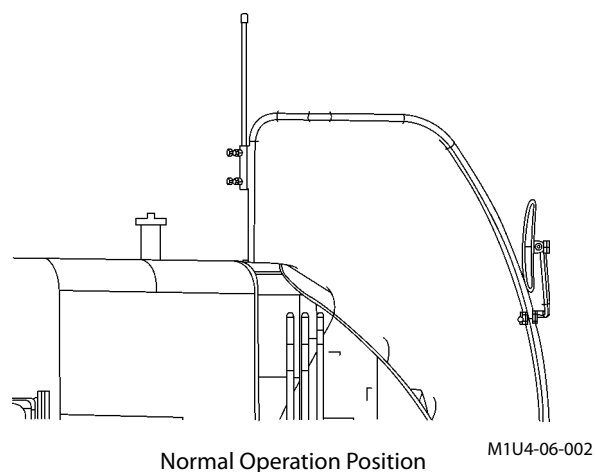
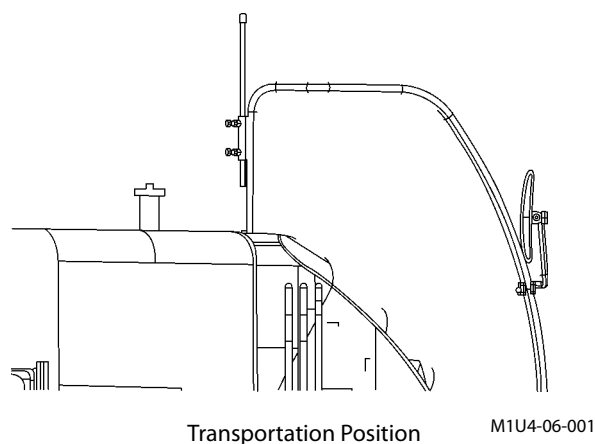

# MAINTENANCE

## LAYOUT

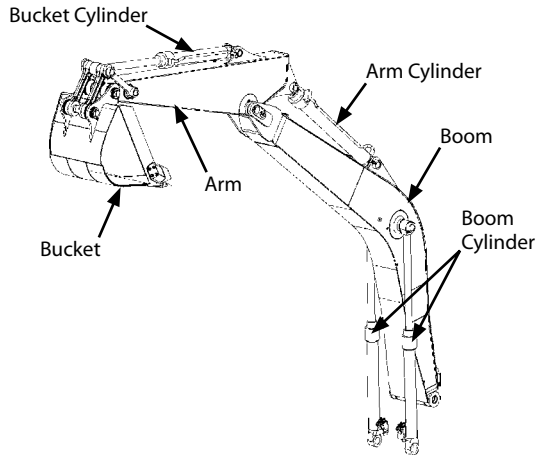

MCBB-01-031

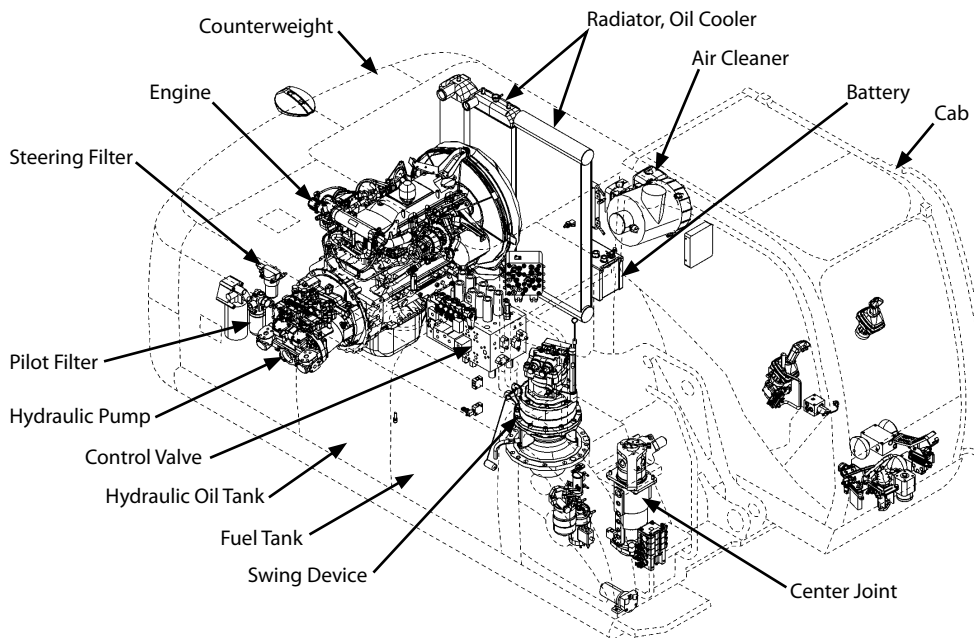

TCJB-01-02-013

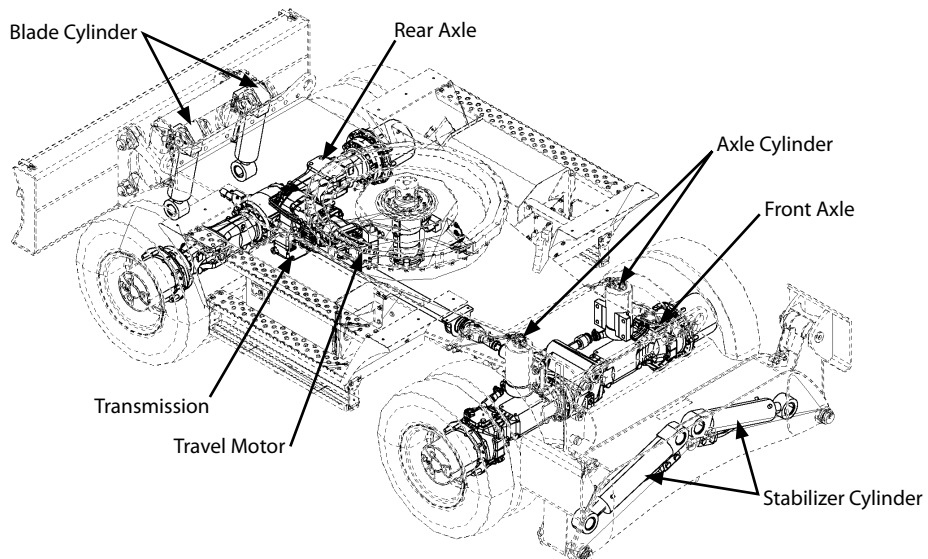

TCJB-01-02-011

## MAINTENANCE

Brand Names of Recommended Grease

Where to be applied	<ul style="list-style-type: none"> <li>• Bucket, Arm and Boom, Swing Gear, Swing Bearing, Propel Shaft, Blade, Stabilizer (ZX140W-3/170W-3/190W-3/210W-3)</li> <li>• Front Axle, Equalizer Pin (ZX170W-3/190W-3/210W-3)</li> </ul>	
Manufacturer	-20 to 40 °C (-4 to 104 °F)	
Nippon Koyu	SEP 2	*2
British Petroleum	BP Energrease	LS-EP2
Caltex Oil	Multifax	EP2
Esso	Beacon	EP2
Idemitsu Kosan	Daphne Coronex Grease	EP2
Mobil Oil	Mobilux	EP2
Nippon Oil	Epinoc Grease	AP2
Shell Oil	Shell Alvania	EP2*1

**NOTE:** The machine shipped from the factory is filled with lubricants marked with .

- \*1 Front Joint Pin and Swing Bearing
- \*2 Swing Gear

Where to be applied	Front Axle, Equalizer Pin (ZX140W-3)	
Manufacturer	-20 to 40 °C (-4 to 104 °F)	
Molykote	Molykote	vn2461c
	Molykote	BR2 Plus *2
Nippon Koyu	HCM Genuine Grease Molybdenum	No.2 *1
British Petroleum	BP Energrease	L-21M
Caltex Oil	Molitex	EP2
Idemitsu Kosan	Daphne Grease	M2
Nippon Oil	Molynoc Grease	AP2
Shell Oil	Alvania Grease	HDX
	Retinax	HDX
Kyodo Yushi	Molylex	MP No2

**NOTE:** The machine shipped from the factory is filled with lubricants marked with .

- \*1 Japanese factory use grease
- \*2 European factory use grease

### Recommended Engine Oil

**IMPORTANT:** Use only genuine Hitachi engine oil as shown below or engine oil equivalent to DH-1 specified in JASO. Failure to do so may deteriorate the engine performance and/or shorten the engine service life. Please be noted that all engine failures caused by using engine oil other than specified are excluded from Hitachi Warranty Policy. Consult your nearest Hitachi dealer for the unclear points.

Brand Names of Recommended Engine Oil

Kind of Oil	Engine Oil		
Application	Engine Crank Case		
Air Temp.	-20 to 30 °C (-4 to 86 °F)	-15 to 40 °C (5 to 104 °F)	
Manufacturer			JASO
Hitachi	Super wide DH-1 10W-30	Super wide DH-1 15W-40	DH-1

# MAINTENANCE

## B. ENGINE

### 1 Engine Oil Level --- check daily

**IMPORTANT:** For most accurate readings, check the oil level every day before starting the machine. Be sure the machine is on a level surface.

1. Remove dipstick (1). Wipe oil off with a clean cloth. Reinsert dipstick (1).
2. Remove dipstick (1) again. Read level. Oil level must be between the circle marks.
3. If necessary, add oil via oil filler cap (2). Be sure to use only recommended oil (see Recommended Engine Oil Chart).

 **NOTE:** Checking the oil level immediately after shut down will result in inaccurate readings. Be sure to allow the oil to settle for at least 10 minutes before checking.

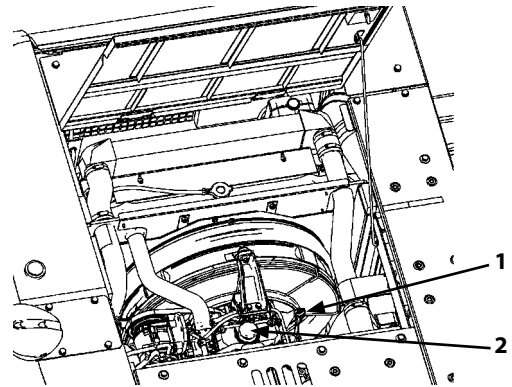

ZX140W-3

MCGB-07-019

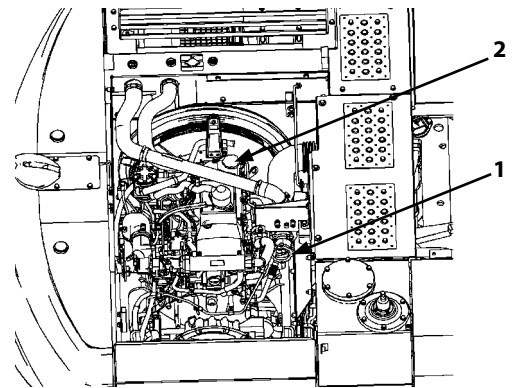

ZX170W-3, 190W-3, 210W-3

MCGB-07-020

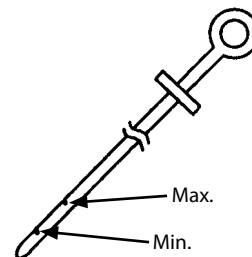

M178-07-011

## MAINTENANCE

### 1 Check Brake Accumulator

1. Start the engine with the brake switch in the column box turned to the P (parking brake) position.
2. After performing warm up operation, move the brake pedal four to five strokes. Then, stop the engine.
3. Turn the key switch ON.
4. Fully step on the brake pedal from 2 to 3 strokes. The buzzer will sound and brake pressure indicator (1) will light when normal. If the buzzer sounds and the brake pressure indicator lights before the brake pedal is stepped on one stroke, the pressure charged in the accumulator is abnormal. Don't travel the machine. Ask your nearest Hitachi dealer to replace the brake accumulator.
5. Repeat the above procedures three times to obtain the correct result and check that no abnormality is present.

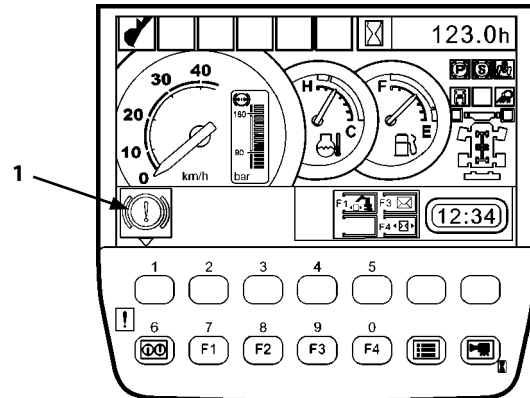

MCGB-03-005

## MAINTENANCE

### Air Bleeding Procedures

**IMPORTANT: If the hydraulic pump is not filled with oil, it will be damaged when the engine is started.**

The machine is equipped with two main pumps. Bleed air from these pumps after changing hydraulic oil.

1. Remove air bleed plugs (5) on each pumps.
2. Fill the pump with oil through air bleed plugs (5) port on each pumps until oil flows out of air bleed plug (5) hole.
3. Temporarily tighten air bleed plugs (5) on each pumps, start the engine and run at slow idle. Loosen one of air bleed plugs (5) slightly until oil flows from plug port to release trapped air completely. Tighten air bleed plug (5). Repeat this step for the rest of plugs.
4. Purge air from the hydraulic system by running the engines at slow idle and operating the control levers slowly and smoothly for 15 minutes.
5. Position the machine as illustrated in the oil level checking procedure.
6. Lower the bucket to the ground.
7. Turn the auto-idle switch off.
8. Stop the engine. Remove the key from the key switch.
9. Pull the pilot control shut-off lever to the LOCK position
10. Check the hydraulic oil tank gauge. Remove cover (2) to add oil if necessary.

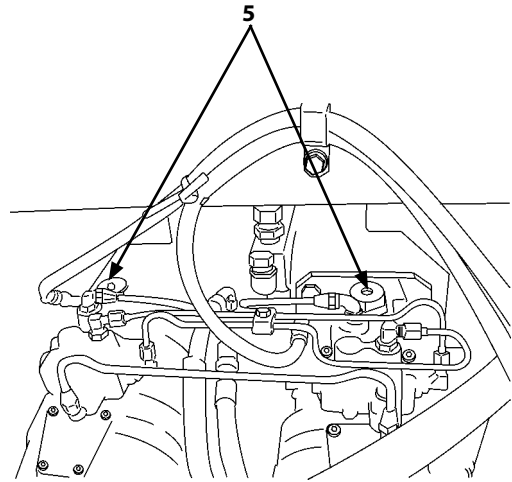

M1U1-07-035

## MAINTENANCE

### Metal Face Seal Fittings

Fittings are used on smaller hoses and consist of a metal flare and a metal flare seat.

1. Inspect flare (10) and flare seat (9). They must be free of dirt or obvious defects.

**IMPORTANT: Defects in the tube flare cannot be repaired. Overtightening a defective flare fitting will not stop a leak.**

2. Tighten fitting (7) by hand.
3. Tighten fitting (7) or nut (8) to the torque values shown. Do not allow hose (5) to twist when tightening fittings.

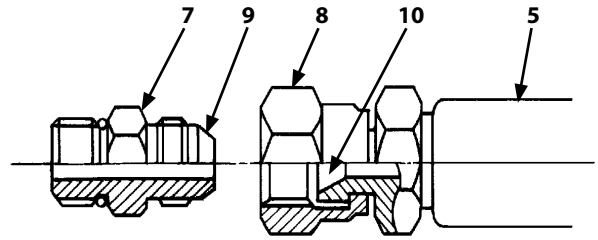

M202-07-051

Width across flats (mm)		17	19	22	27
Fastening torque	N·m	24.5	29.5	39	78
	(kgf·m)	(2.5)	(3)	(4)	(8.0)
	(lbf·ft)	(18)	(21.5)	(29)	(58)

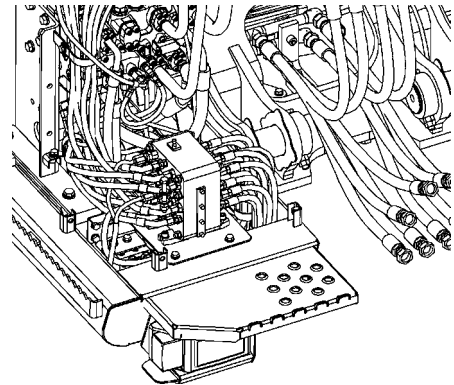

MCGB-07-047

### Pilot Piping Fittings (For shuttle valve)

Width across flats (mm)		19
Fastening torque	N·m	34.3
	(kgf·m)	(3.5)
	(lbf·ft)	(25.3)

## MAINTENANCE

- 6 Check Fuel Hoses**  
 --- daily  
 --- every 250 hours

**⚠ CAUTION: Fuel leaks can lead to fires that may result in serious injury.**  
**To avoid this hazard :**

1. Park the machine on a firm, level surface. Lower the bucket to the ground. Stop the engine. Remove key from the key switch. Pull the pilot control shut-off lever to the LOCK position.
2. Check for kinked hoses, and hoses that rub against each other parts for leaks. Check hoses at the check points indicated below for leaks and other damage that may result in future leaks. If any abnormalities are found, replace or retighten them, as shown in Table 4.
3. Repair or replace any loose or damaged hoses. Never install bent or damaged hoses.

Table 4. Hoses

Interval (hours)	Check Points	Abnormalities	Remedies
Daily	Hose ends	Leak (1)	Retighten or replace
	Soutache braid hose	Friction (2)	Replace
		Crack (2)	Replace
Every 250 hours	Soutache braid hose	Crack (3)	Replace
	Hose ends	Crack (4)	Replace
	Hose	Bend (5)	Replace
	Hose	Collapse (6)	Replace (Use proper bend radius)
	Hose ends and fittings	Deformation or corrosion (7)	Replace

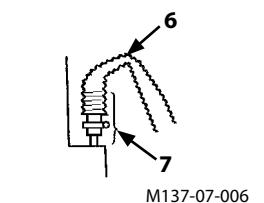
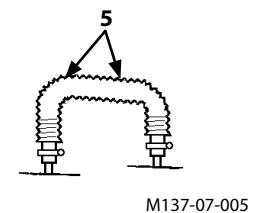
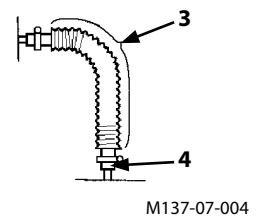
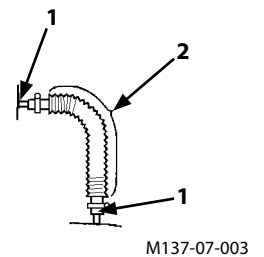

Fig. 1

**✎ NOTE:** Refer to the illustrations in Fig.1 for each check point location or for a description of the abnormality. Use genuine Hitachi parts.

## MAINTENANCE

### Check electrolyte specific gravity

**CAUTION:** Battery gas can explode. Keep sparks and flames away from batteries. Use a flashlight to check the battery electrolyte level.

Sulfuric acid in battery electrolyte is poisonous. It is strong enough to burn skin, eat holes in clothing, and cause blindness if splashed into the eyes.

Never check the battery charge by placing a metal object across the posts. Use a voltmeter or hydrometer.

Always remove the grounded (–) battery clamp first and replace it last.

#### Avoid hazard by:

1. Filling batteries in a well-ventilated area.
2. Wearing eye protection and rubber gloves.
3. Avoiding breathing fumes when electrolyte is added.
4. Avoiding spilling or dripping electrolyte.
5. Using proper booster battery starting procedures.

#### If you spill acid on yourself:

1. Flush your skin with water.
2. Apply baking soda or lime to help neutralize the acid.
3. If splashed in eyes, flush with water for 10 to 15 minutes. Get medical attention immediately.

#### If acid is swallowed:

1. Drink large amounts of water or milk.
2. Then drink milk of magnesia, beaten eggs, or vegetable oil.
3. Get medical attention immediately.

**IMPORTANT:** Check the specific gravity of the electrolyte after it is cooled, not immediately after operation.

Check the electrolyte specific gravity in each battery cell.

The lowest limit of the specific gravity for the electrolyte varies depending on electrolyte temperature. The specific gravity should be kept within the range shown below. Charge the battery if the specific gravity is below the limit.

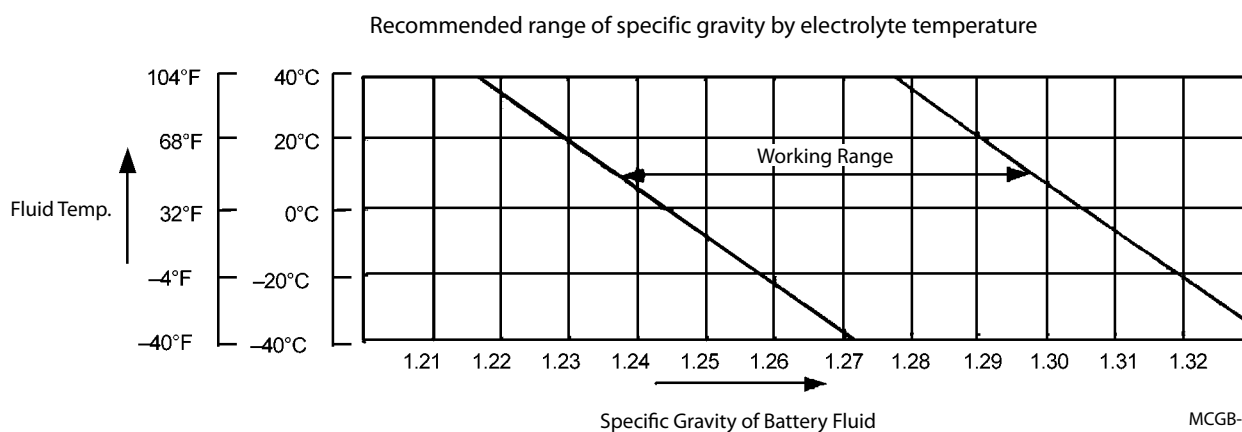

## REPLACE BATTERIES

Your machine has two 12-volt batteries with negative (–) ground.

If one battery in a 24-volt system has failed but the other is still good, replace the failed battery with one of the same type. For example, replace a failed maintenance-free battery with a new maintenance-free battery. Different types of batteries may have different rates of charge. This difference could overload one of the batteries and cause it to fail.

## MAINTENANCE

### 4 Clean and Replace Air Conditioner Filter Clean Filter

**Circulating Air Filter --- every 500 hours**

**Fresh Air Filter --- every 500 hours**

#### Replace Filter

**Circulating Air Filter --- After cleaning 6 times  
or so**

**Fresh Air Filter --- After cleaning 6 times or so**

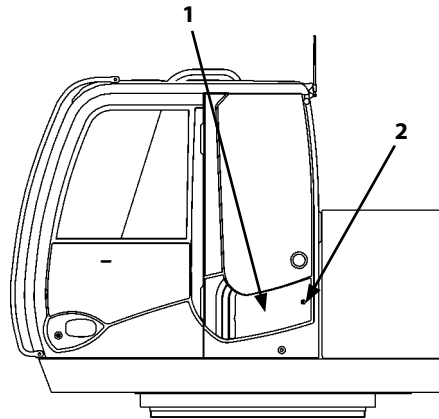

M1U1-07-010

#### Removing Fresh Air Filter

1. While pushing the cover side above the rear deck, raise the upper cover to remove.
2. After removing the upper cover, hold the grip of fresh air filter (1) and pull it out in the vertical direction.

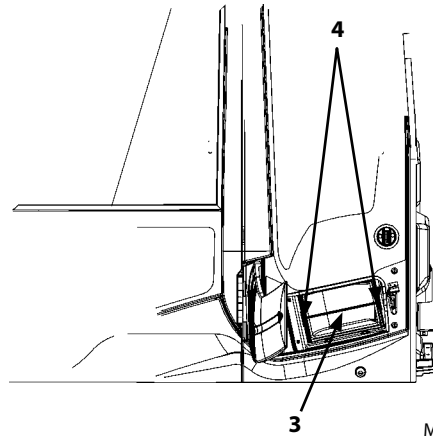

M1U1-07-011

#### Removing Recirculation Filter

1. Recirculation filter (2) is located under the rear deck.
2. Holding grips (3), pull them toward you to remove.

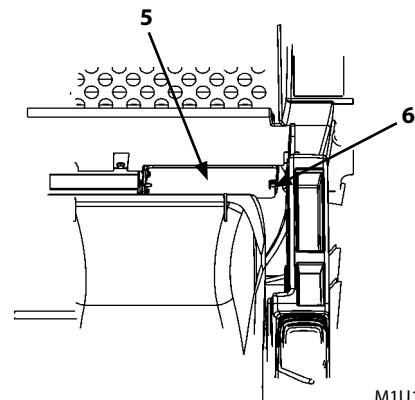

M1U1-07-012

## MAINTENANCE

1. Retighten the engine cushion rubber mounting bolts and nuts.
2. Retighten the engine bracket mounting bolt.

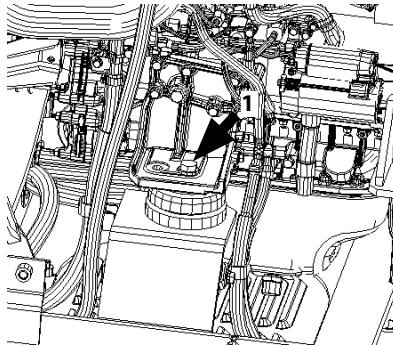

ZX140W-3 (Fan Side)  
MCGB-07-104

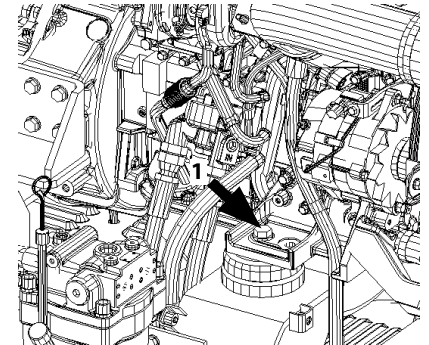

ZX140W-3 (Fan Side)  
MCGB-07-105

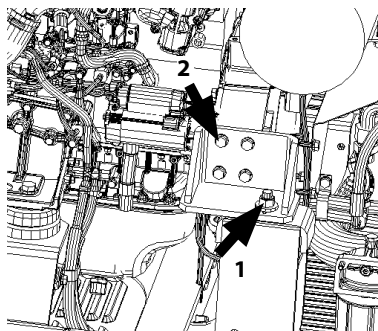

ZX140W-3 (Pump Side)  
MCGB-07-106

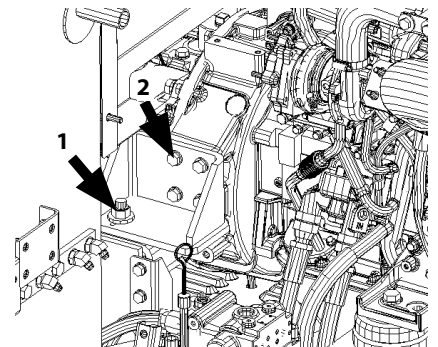

ZX140W-3 (Pump Side)  
MCGB-07-107

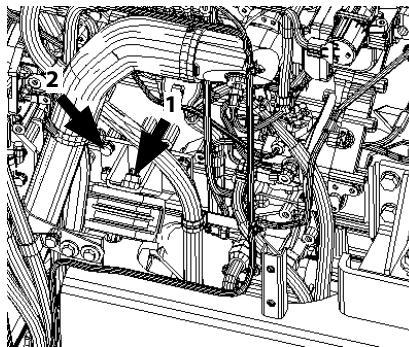

ZX170W-3, 190W-3, 210W-3 (Fan Side)  
MCGB-07-108

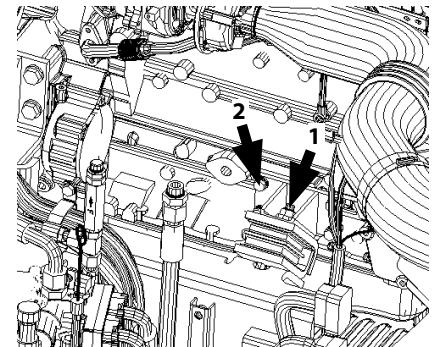

ZX170W-3, 190W-3, 210W-3 (Fan Side)  
MCGB-07-109

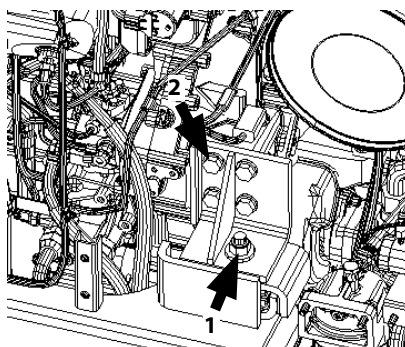

ZX170W-3, 190W-3, 210W-3 (Pump Side)  
MCGB-07-110

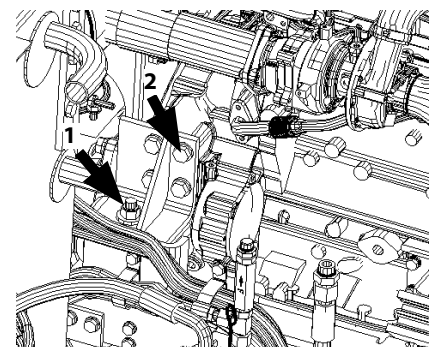

ZX170W-3, 190W-3, 210W-3 (Pump Side)  
MCGB-07-111

## MAINTENANCE UNDER SPECIAL ENVIRONMENTAL CONDITIONS

### MAINTENANCE UNDER SPECIAL ENVIRONMENTAL CONDITIONS

Operating Conditions	Precautions for Maintenance
Muddy Soil, Rainy or Snowy Weather	<p>Before Operation: Check the tightness of plug and all drain cocks.</p> <p>After Operation: Clean the machine and check for cracks, damaged, loose or missing bolts and nuts. Lubricate all necessary parts without delay.</p>
Near the Ocean	<p>Before Operation: Check tightness of plugs and all drain cocks.</p> <p>After Operation: Thoroughly clean the machine with fresh water to wash off salt. Service electrical equipment often to prevent corrosion.</p>
Dusty Atmosphere	<p>Air Cleaner: Clean the element regularly at shorter service intervals.</p> <p>Radiator: Clean the oil cooler screen to prevent clogging of the radiator core.</p> <p>Fuel System: Clean the filter element and strainer regularly at shorter service intervals.</p> <p>Electrical Equipment: Clean them regularly, in particular, the commutator surface of the alternator and starter.</p>
Rocky Ground	<p>Chassis: Carefully operate while checking for cracks, damage and loose bolts and nuts.</p> <p>Front Attachment: Standard attachment may be damaged when digging rocky ground. Reinforce the bucket before using it, or use a heavy duty bucket.</p>
Freezing Weather	<p>Fuel: Use high quality fuel suitable for low temperature.</p> <p>Lubricant: Use high quality low viscosity hydraulic oil and engine oil.</p> <p>Engine Coolant: Be sure to use antifreeze.</p> <p>Battery: Fully charge the batteries regularly at shorter service intervals. If not fully charged, electrolyte may freeze.</p> <p>Chassis: Keep the chassis clean. Park the machine on a hard surface to prevent the tire from freezing to the ground.</p>
Falling Stones	<p>Cab: Provide a cab guard to protect the machine from falling stones when necessary.</p>

## TROUBLESHOOTING

	<b>Problem</b>	<b>Cause</b>	<b>Solution</b>
<b>Brake</b>	<b>Brake operates unevenly.</b>	Worn brake lining Oil leaks from wheel cylinder	* Replace * Repair and replace
	<b>Brake squeaks when applied</b>	Worn lining	* Replace and repair
<b>Trans- mission</b>	<b>Noisy</b>	Lack of gear oil or deteriorated quality of oil Worn transmission inner parts Broken gear and/or bearing	Refill or change oil.  * Repair and/or replace faulty parts. * Repair and/or replace faulty parts.
	<b>Gearshift is not achieved.</b>	Oil leaks from transmission circuit Mixed air in transmission circuit Faulty transmission control valve Faulty shift interlock section	* Repair and replace Bleed air. * Repair or replace. * Repair or replace faulty parts.
	<b>Power is not transmitted.</b>	The parking brake release system remains ON Broken clutch Broken shafts and/or gears	Discharge the parking brake release grease.  * Replace. * Replace.

## SPECIFICATIONS

### SPECIFICATIONS

#### ZX170W-3 (Standard GAUGE, Standard CHASSIS, REAR BLADE)

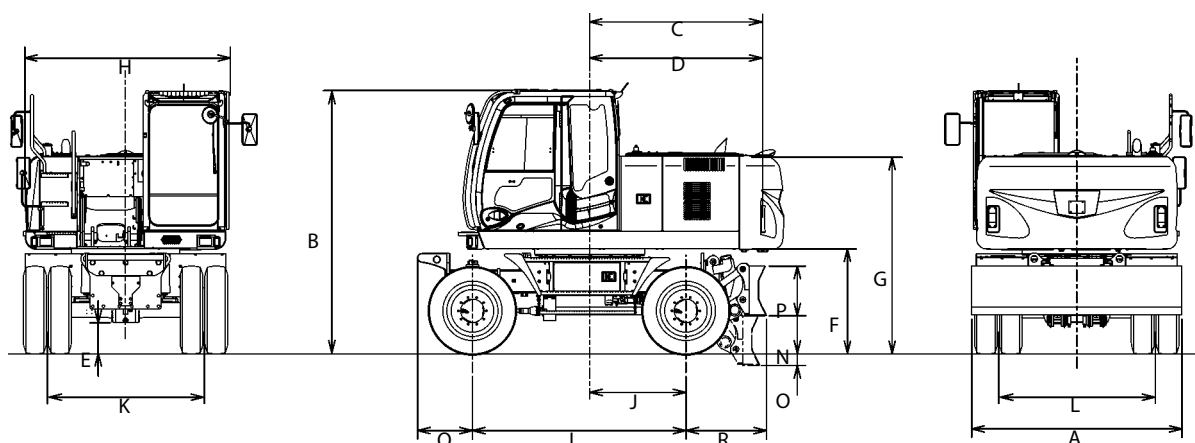

MCGB-12-008

Type of Front-End Attachment		Monoblock boom
Type of Arm	–	2.58 m (8 ft 6 in)
Bucket Capacity (Heaped)	m <sup>3</sup> (yd <sup>3</sup> )	PCSA 0.60m <sup>3</sup> (0.78yd <sup>3</sup> ), CECE 0.55m <sup>3</sup>
Operating Weight	kg (lb)	16600 (36600)
Basic Machine Weight	kg (lb)	13600 (30000)
Engine		ISUZU AI-4HK1X
Engine Power	SAE J1349 net	107 kW/2000 min <sup>-1</sup> (145 PS/2000 rpm)
	ISO 9249 net	
	EEC 80/1269 net	
A: Overall Width (Excluding Rearview Mirrors)	mm (ft-in)	2550 (8' 4")
B: Cab Height	mm (ft-in)	3130 (10' 3")
C: Rear End Swing Radius	mm (ft-in)	2320 (7' 7")
D: Rear End Length	mm (ft-in)	2320 (7' 7")
E: Minimum Ground Clearance	mm (ft-in)	350 (1' 2")
F: Counterweight Clearance	mm (ft-in)	1235 (4' 1")
G: Engine Cover Height	mm (ft-in)	2345 (7' 8")
H: Overall Width of Upperstructure	mm (ft-in)	2450 (8' 1")
I: Wheelbase	mm (ft-in)	2550 (8' 4")
J: Swing-center to Rear Axle	mm (ft-in)	1150 (3' 9")
K: Front Wheel Tread	mm (ft-in)	1945 (6' 5")
L: Rear Wheel Tread	mm (ft-in)	1945 (6' 5")
M: Outrigger Spread	mm (ft-in)	–
N: Max. Raising Height	mm (ft-in)	445 (1' 6")
O: Max. Digging Depth	mm (ft-in)	145 (6")
P: Blade Height	mm (ft-in)	590 (1' 11")
Q: Front Axle to Front of Chassis	mm (ft-in)	605 (2' 0")
R: Rear Axle to Rear of Chassis	mm (ft-in)	965 (3' 2")
Tire Size	–	10.00-20 16PR
Swing Speed	min <sup>-1</sup> (rpm)	12.2
Travel Speed (fast/slow/creeper) *	km/h (mph)	35/8.6/2.6 (21.7/5.3/1.6)
Gradeability	degree (%)	35 (70)

NOTE: \* The specification not matching the local regulation is excluded.

## SPECIFICATIONS

### Specifications

#### ZX190W-3 (FRONT OUTRIGGER REAR OUTRIGGER)

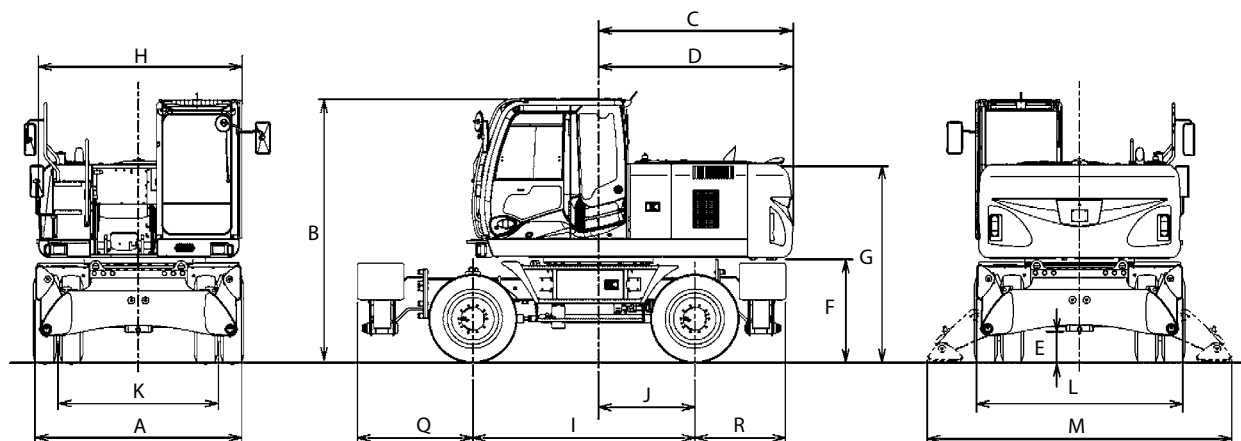

MCGB-12-019

Type of Front-End Attachment		Monoblock boom
Type of Arm	–	2.71 m (8 ft 11 in)
Bucket Capacity (Heaped)	m <sup>3</sup> (yd <sup>3</sup> )	PCSA 0.70 m <sup>3</sup> (0.92 yd <sup>3</sup> ), CECE 0.60 m <sup>3</sup>
Operating Weight	kg (lb)	19700 (43400)
Basic Machine Weight	kg (lb)	16350 (36000)
Engine		ISUZU AI-4HK1X
Engine Power	SAE J1349 net	122 kW/2000 min <sup>-1</sup> (166 PS/2000 rpm)
	ISO 9249 net	
	EEC 80/1269 net	
A: Overall Width (Excluding Rearview Mirrors)	mm (ft-in)	2550 (8' 4")
B: Cab Height	mm (ft-in)	3130 (10' 3")
C: Rear End Swing Radius	mm (ft-in)	2320 (7' 7")
D: Rear End Length	mm (ft-in)	2320 (7' 7")
E: Minimum Ground Clearance	mm (ft-in)	350 (1' 2")
F: Counterweight Clearance	mm (ft-in)	1235 (4' 1")
G: Engine Cover Height	mm (ft-in)	2345 (7' 8")
H: Overall Width of Upperstructure	mm (ft-in)	2450 (8' 1")
I: Wheelbase	mm (ft-in)	2650 (8' 8")
J: Swing-center to Rear Axle	mm (ft-in)	1150 (3' 9")
K: Front Wheel Tread	mm (ft-in)	1945 (6' 5")
L: Rear Wheel Tread	mm (ft-in)	1945 (6' 5")
M: Outrigger Spread	mm (ft-in)	3440 (11' 3")
N: Max. Raising Height	mm (ft-in)	–
O: Max. Digging Depth	mm (ft-in)	–
P: Blade Height	mm (ft-in)	–
Q: Front Axle to Front of Chassis	mm (ft-in)	1380 (4' 6")
R: Rear Axle to Rear of Chassis	mm (ft-in)	1085 (3' 7")
Tire Size	–	10.00-20 16PR
Swing Speed	min <sup>-1</sup> (rpm)	12.2
Travel Speed (fast/slow/creeper) *	km/h (mph)	35/8.6/2.6 (21.7/5.3/1.6)
Gradeability	degree (%)	34 (67)

NOTE: \* The specification not matching the local regulation is excluded.

## OPTIONAL ATTACHMENTS AND DEVICES

- Blade/Outrigger status indicator (5)  
Display the combination of the blade and the outrigger. The blade and/or outrigger selected by operating the front/rear attachment selection switch and right/left selection switch is indicated in green.

 **NOTE:** The illustration show a machine equipped with the front outrigger and rear blade as an example.

**IMPORTANT:** Consult your nearest Hitachi dealer for setting the combination of the blade and the outrigger.

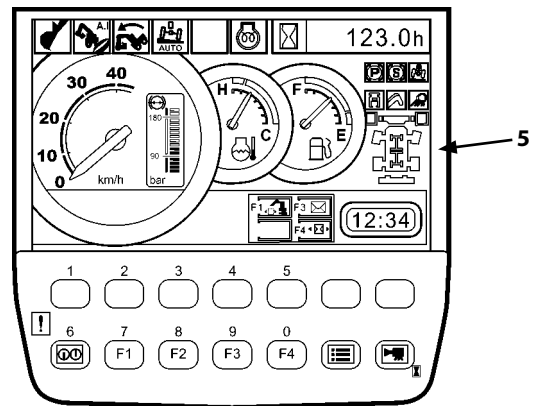

TCJB-05-02-042

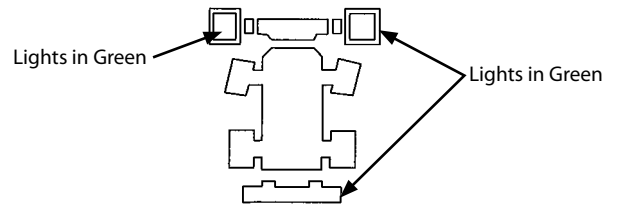

When the blade/outrigger are activated

TCJB-05-02-102

CLICK HERE TO **DOWNLOAD** THE COMPLETE MANUAL

- Thank you very much for reading the preview of the manual.
- You can download the complete manual from: [www.heydownloads.com](http://www.heydownloads.com) by clicking the link below



- Please note: If there is no response to CLICKING the link, please download this PDF first and then click on it.

CLICK HERE TO **DOWNLOAD** THE COMPLETE MANUAL